

COYNE

ELECTRICAL and RADIO

TROUBLE SHOOTING MANUAL

FOR HOME STUDY AND REFERENCE

**COYNE
ELECTRICAL~RADIO
TROUBLE SHOOTING
MANUAL**

Copyright 1946 by
COYNE ELECTRICAL SCHOOL
Chicago, Illinois

No portion of this book may be reproduced
by any printing process without permission
from the publishers.

Printed in United States of America

★

SHOP PRINTS

MOTOR DIAGRAMS

D. C. and A. C.

AUTOMOTIVE

ELECTRONICS

RADIO

REFRIGERATION

DIESEL

★

ELECTRICAL

DICTIONARY

★

SPARE-TIME

JOB PLANS

★

PREPARED AND PUBLISHED FOR HOME STUDY AND
FIELD REFERENCE BY THE COYNE ELECTRICAL
SCHOOL, 500 S. PAULINA ST., CHICAGO, ILLINOIS. ALL
THE DATA IN THIS MANUAL, INCLUDING THE ACTUAL
SHOP PRINTS AND MOTOR DIAGRAMS HAS BEEN
FIELD TESTED IN THOUSANDS OF INDUSTRIAL CON-
CERNS THROUGHOUT THE COUNTRY.

Property of _____

DIRECTORY

HOW TO LOCATE THE VARIOUS SHOP PRINTS AND MOTOR DIAGRAMS

THE purpose of this **DIRECTORY** is to aid the user of this Manual in locating information on any subject covered. As an example, if you want to study the special section on step-by-step Trouble Shooting procedure, the **Directory** tells you it can be found on Pages 12 to 32. Likewise, if you wanted to check up on the definition of some Electrical phrase or word, the **Directory** would tell you exactly where you could find the **Electrical Dictionary** section. The same thing applies in the event you want to study some motor diagrams on some certain subjects—the **Directory** tells you **WHERE ALL** of the diagrams on that particular subject are to be found.

On the adjoining page, you will note we have the first page of our **MASTER INDEX**. Now, the **Directory** differs from the **Master Index** in this respect. The **MASTER INDEX** is much more detailed than the **Directory** and tells you where **EVERY** specific **SUBJECT** can be found. The **Directory**, on the other hand, tells you where each branch (as a whole) is covered in the **Manual**. We furnish both these methods of **INDEXING IN OUR BOOK FOR YOUR CONVENIENCE IN LOCATING THE INFORMATION YOU NEED QUICKLY**.

	Pages		Pages
Master Index	V-IX	A. C. Transformers	175-181
Acknowledgments	X	A. C. Polyphase Motors	183-199
How to Use the Coyne Electrical and Radio Trouble Shooting Manual.....	5-11	A. C. Single Phase Motors	200-228
Step by Step Electrical Trouble Shooting Program	12-32	A. C. Motor Starters	229-256
Electrical Diagrams — What They Mean — How to Use Them.....	33-38	A. C. Controllers	257-274
		A. C. Starters and Controllers	275-294

ELECTRICAL WIRING DIAGRAMS

Electrical Circuit and Wiring Diagrams.... 39-70

DIRECT CURRENT WIRING DIAGRAMS

Instructions for Reading D. C. Motor Diagrams	71-73
Direct Current Motors	74-89
“ “ Generators	90-96
“ “ Armature Windings	97-113
“ “ Testing	111-118
Direct Current Motors, Starters and Controls	119-159

ALTERNATING CURRENT DIAGRAMS

Instructions for Reading A. C. Diagrams A. C. Principles and Circuits	160-175
--	---------

Electrical Refrigeration and Air Conditioning Diagrams	295-340
Automotive Electricity	341-370

RADIO AND TELEVISION DIAGRAMS

Radio Principles and Circuits	371-389
Radio Tubes and Receiver Components	390-402
Radio Receivers and Controls	403-431
Sound and P. A. Systems	432-446
Photocell Applications	447-451
Television Systems	452-460
Radio Transmission and Transmitters....	461-484
Radio Testing and Adjustment	485-521
Radio Service Diagrams and Data	522-565
Radio-Electricity and Electronic Dictionary	565-591
Spare Time Job Plans	593-612

MASTER INDEX

V

The Master Index is furnished for your convenience in locating the Shop Prints and other information you want. Subjects are arranged alphabetically like a classified telephone directory. Use this Index often—it saves time for you. Definitions and explanations of words and terms are given in the Electrical, Radio and Electronic Dictionary—Pages 566 to 590.

Subject	Page	Subject	Page	Subject	Page
A					
Absorption, coefficients, sound	430	Automobile radio installation	432-33	Charger, magnet	343
refrigeration	322, 325	interference	433	Charging, oil, refrigeration	335
A-c apparatus	160-294	vibrators	434	refrigerants	326-31
Acoustics, see <i>Sound</i> .		testers for	435	Circuits	
Advertising devices, electrical	595-96	Automotive electricity	341-70	a-c, power in	174
Air conditioning, central fan	315	generator rewinding	607-8	open, locating	17-20
controls for	315	Auto-transformer motor starter		parallel, tests of	31
heat transfer coefficients	337	magnetic		parts of	13
room cooler	314	259-60, 265-66, 269-71, 276, 278		plate, radio	392
purging of, refrigeration	326, 332	manual	261-64, 277	series, impedance of	165
Alarms, annunciator types	48				
bell type	50	B			
phototube operated	457	Baffles, loud speaker, sizes of	397	short, kinds of	15
railway crossing	47	Balanced armature loud speaker	502	locating	20-22
Aligning, receiver		Balancing pressures, refrigeration	332	testers for	17, 25-31
oscilloscope for	507	Ballast tubes, radio, circuits of	431	tracing of	42
superheterodyne	504	Barrier layer photocell	452	Clapper relay	45
without signal generator	508-9	Battery ignition, principles of	353	Class A, B, and C radio amplifiers	443
Allen-Bradley controls		Batteries, automobile, ground polarities		Clock, motor for	212
148, 247, 255-56, 269		384		time switch with	275
Alternating-current apparatus					
160-294		storage, cadmium test for	365	Code, color, RMA	499, 590
(See names of apparatus and parts)		high-rate discharge test	370	radio signal	482-83
Ammeters, testing with	29	Bearing, sleeve type	292	Coil, armature, forming of	112-13
Amplidyne generator	158	Bell, alarm circuit for	50	blowout, magnetic, action of	147
Amplifier, audio-frequency, public		polarized, a-c type	53	field, tests of	118
address 441, 443, 445-47, 453		testing with	27	ignition, testing of	345
transmitter	467, 471	Bellows type shaft seal	301	radio, Q factor of	384
class A, B, C, etc.	443	Bias, grid, methods of obtaining	393	reactance of	384
modulated, transmitter	467	Blowout, arc, De-ion type	250	Tesla	180
public address	441, 443, 445-47, 453	magnetic, action of	147	Cold-cathode rectifier tube	401
push-pull	395	Brake, Prony, motor testing	77, 132	Cold control, thermostats for	307
resistance coupled	395	Braking, dynamic, action of	142	Color codes, RMA	499, 590
sound recording	450	circuits for	124, 126	matcher, phototube type	452
transformer coupled	395	drum controller for	143-46	Commercial refrigeration	
Amplitude modulation	468	magnetic controller for	155	cabinet insulation	340
Analyzer, radio, meter for	510	Broadcasting transmitter	474	loads for	340
use of	503	Brushes, motor, fitting and setting	85	refrigerator for	311
Annunciator alarms	48	Building wiring, diagrams of	61, 63	Commutator construction	84
wiring	48	symbols for	54	tests of	85
Antenna, directional effect of	387	tests of	25, 67	Compensator starter, see <i>Starter, motor, a-c, auto-transformer</i> .	
insulators for	387	Buildings, heat transfer coefficients for	337	Compound-wound generators	97
lead-ins	388-89	Bungalow wiring	58-61	motors	80
principles of	386-90	Burglar alarms, see <i>Alarms</i>		Compressors, refrigeration	
types of	385, 389	Butt welder, transformer for	183	efficiency tests of	323
Arc blowout, De-ion type	250	Buzzers, testing with	27	overhauling	334
magnetic	147	C			
ladder, display	287, 595	Cadmium test, storage battery	365	reciprocating type	301
transmitter, radio	480	Camera tube, television	461-62	remove and install	333
welding	159, 604-6	Cams, principles of	291	rotary types	301
Areas, formulas for	162	Capacitance, see <i>Capacity</i>		valve test of	324
Armature					
equalizer connections	110	Capacitive reactance	164, 377	Condenser microphone	440
generator, construction	84	Capacitor, see <i>Condenser</i>		Condensers, electric	
insulation	114	motors		action of	375
motor, construction	84	multi-speed	220-38	capacity test of	501
testing, growler for	115-16	principle of	230, 232	color codes for	499
meter for	117-18	reversible	221	power factor of	384
winding, automotive generator	607-8	223-26, 230, 232-38		correction with	163, 176
coil forming for	112-13	Capacity, antenna	386-90	reactance of	384
data sheet for	110	condenser, test of	501	tester for	502
equalizers	110	formulas for	381	testing of	403, 500-502
lap	100-106	plates, parallel	384	Condensers, refrigeration	302
materials for	114	Capillary tube refrigeration control	312	Conductors, number in conduit	163
tools for	114	Carbon microphone	440	Conduit, rigid, size required for	
wave	104, 107-9	pile motor starter, a-c	255-56	conductors	163
Attenuator, public address	444	d-c	148	wiring, test of	67
Audio amplifier, public address		Carrene, temperatures and pressures	319	Cone pulley drive	289
441, 443, 445-47, 453		Carthwise three-way switch circuit	56	Consequent pole windings,	
transmitter	467, 471	Cathode-ray oscillograph	506	three-phase	196-97
Auto-starter, see <i>Starter, motor, a-c, auto-transformer</i> .		oscilloscope, aligning receiver with	507	Continuous wave receiver	484
		tube, kinescope	464	transmitter	475-76
		Central energy telephone	52	Controls	
				fuel automotive	361

Subject	Page
CONTROLS (Cont.)	
motor, a-c, jogging	273
phototube for	254, 271
reversing	276, 280-81
speed, three-phase	278-79
wound rotor	207
motor, d-c, drum types	137-41
dynamic braking	126
printing press	136
remote	47
speed	93, 128, 153
remote, relays for	248
self-synchronous	188, 285-86
Selsyn	188, 285-86
volume, radio, automatic	419

Controllers

drum, d-c motor	137-41
dynamic braking	143-46
wound rotor motor	282-84
motor, d-c	123-55
printing press	136
Converter, six-phase	173
Cooler, room, unit for	314
Copper oxide rectifier	401
Coupling coefficient, formulas	381
Crosley radio receivers	525
Crystal microphone	440
pickup, phonograph	425-27
Cumulative compound generator	97
motor	80
Current, alternating, apparatus for	160-294
direct, apparatus for	71-159
power circuits, formulas	162-63
voltage regulators, automotive	359
Cutler-Hammer controls	130, 135, 150, 153, 251, 257, 263, 270
Cycle, four-stroke, engine	343, 360
refrigeration	311
two-stroke, engine	362

D

D-c apparatus	71-159
Decalorator refrigeration	316
Decibels, sound values of	439

Definitions, electrical and radio	566-90
Dehydrators, refrigeration	336
De-ion arc quencher	250
Detection, diodes for	372
Detector, power, radio	394
Diagrams, wiring, kinds of	35
meaning of	35
reading of	36-38, 590-91
schematic, meaning of	35
Diaphragm loud speaker	502

Dictionary, electrical and radio	566-90
Diesel engine, four-cycle	360
two-cycle	363
Differential compound generator	97
motor	80
gearing, principle of	290
Diodes, detection with	372

Direct-current apparatus	71-159
Disc drive	289
sound recording on	448
Discharging refrigerants	326
Displays, electrical	287, 595-96
Distribution system details	181-82
Diving duck display	596
Dixie relay	45
Double-button microphone	440
pole switches, uses of	55
Drive, differential	290
disc	289
pulley, variable speed	289
Drop, voltage, d-c circuit	491-92
examples of	44
experiment with	43
Drum controllers, d-c motor	137-41
dynamic braking	143-46
wound rotor motor	282-84
service, refrigeration	329

Subject	Page
Dry rectifier	401
Drying of electric machinery	599-600
Duck, diving, display	596
Duplex lap windings	105-6
Dynamic braking, action of	142
circuits for	124, 126
drum controllers for	143-46
magnetic controller	155
loud speaker	502
connections of	396
tester, radio receiver	519-20
Dynamo, see <i>Generators, d-c</i>	
Dynamotor, internal diagram	98
principles of	473

E

Efficiency test, compressor	323
Electric clock motor	212
eye burglar alarm	457
refrigeration	295-340
welding	159, 604-6

Electrical dictionary	566-90
Electricity, automotive	341-70
Electrolier switch, uses of	55
Electrolux refrigeration units	322-25
Electromagnetic induction	376, 487
Element windings, armature	101
Emerson radio receivers	526-31

Engines

automotive, vacuum tests on	369
voltage testing	366-67
Diesel, four-cycle	360
two-cycle	363
four-cycle	343, 360
internal combustion, principle	343
two-cycle	362
Epicyclic gearing	291
Equalizers, armature	110
Evaporator, float type	300
trouble with	304
Expansion valves, refrigeration	306

F

Factor, power, see <i>Power factor</i>	
Fader, public address	444
Farm light plant	341
motors, applications	244-45
Farnsworth radio receivers	532-36
Field coils, tests of	118
protection, d-c motor	124-25
revolving	185, 187
speaker, power supply for	396
winding, automotive generator	608
Film, sound recording on	448
Filters, radio frequency	394
Firing orders, engine	343
Fleming's left-hand motor rule	76
Float, high side	303, 309
troubles with	310
low side	303-4
troubles with	305
Flow meter, Venturi	288
FM radio	414-18, 468
F-114 refrigerant, temperatures and pressures for	319
Foot-candle illumination standards	62
Ford V-8 wiring diagram	368
Form winding, armature coils	112-13
Four cycle engine	343, 360
way switch, lamp control	55-56
Freezer, ice cream	317
Freon-12 refrigerant, temperatures and pressures for	319
Frequency, formula for	384
modulation	414-18, 468
Friction disc drive	289
Fuel controls, automotive	361
injection, engine	364
Full-wave rectifier	401

G

Gauges, refrigeration, installation	323
Gearing, differential	290
epicyclic	291

Subject	Page
General Electric controls	273, 276-77
generators	97
motors	211, 217-18, 222-26, 232-38, 265
radio receivers	537-40

Generators

a-c, paralleling	167, 170
phasing out	167, 170
poles of	160
principles of	160, 170
switchboard connections	168
synchronizing	167, 170
Amplidyne	158
automotive, controls for	356-59
rewinding of	607-8
testing	348, 366-67
third brush	347
d-c, action of	74, 92
characteristics, tests of	99
compound wound	97
construction of	83
interpoles for	75
paralleling of	94
switchboard connections	156
troubles with	92
insulation tests of	119
signal, calibration check	509
welding, d-c motor for	608-9
series type	95
wind driven	486, 601-3
Glow lamp, television	466
Grid bias, methods of obtaining	393
Grounds, accidental, locating	22
automobile battery polarity	384
neutralizer quenching of	184
Growlers, construction of	294
specifications for	115
tests with	116

H

Half-wave rectifier	401
Heat transfer coefficients, air conditioning	337
Herveen refrigerant, temperatures and pressures for	319
High rate discharge test, battery	370
resistance, tests for	20
side float	303, 309
troubles with	310
tension magneto	349
Horsepower, formulas for	162
House meters, circuits in	65
Humidistat, air conditioner with	315
Hydraulics, principles of	288

I

Ice cream freezer	317
Iconoscope television camera tube	461-62
Ignition, battery, principles of	353
coil, testing of	345
system testing, voltage method	366-67
timing method	355
Illumination, standards for	62
Impedance, a-c circuit	165
principles of	378
series circuit	165, 378
test for	166
Inching control, motor	124
Indicating wattmeter	121
Indicators, position	188
tuning, radio	419
volume, transmitter	470
Inductance, antenna	387
principles of	376
Induction, electromagnetic	376, 487

Induction motors

alterations of	610-12
construction of	185-86
currents for	163
efficiency tests of	177
frequency alteration	610
phase alteration	610
power factor correction	176
test	177

(Continued)

Subject	Page
INDUCTION MOTORS (Cont.)	
requirements.....	175
speed alteration.....	610
stator connections.....	186
two-voltage.....	200-202
voltage alteration.....	610
Inductive reactance.....	164, 377
Inductor magneto.....	350
Injection, engine fuel.....	364
Input circuits, public address.....	444
Insulation, armature.....	114
tester for.....	120
testing, motor and generator.....	119
Insulators, antenna.....	387
Integrating wattmeter.....	121
Interference, radio, auto-radio.....	433
locator.....	521-24
static.....	390
Internal connections, testing of.....	32
Interpoles, motor, purpose of.....	75

J-K

Jobs, spare time.....	593-612
Jogging controls, motor.....	273
Jumping ring display.....	287, 595
Keystoning circuit, television.....	462
Kilowatt-hour meter circuits.....	65
Kinescope, television.....	464
Kohler farm light plant.....	341

L

Ladder arc display.....	287, 595
Lamp control, multi-location.....	56-57
switches, double-pole.....	55
four-way.....	55
single-pole.....	55
three-way.....	55, 57
testing with.....	25
Lap winding, armature.....	100-106
stator, three-phase.....	190, 192-95
two-phase.....	191
Lead-ins, antenna.....	388-89
Leak tests, refrigerant.....	330
Left-hand rule motor.....	76
Letter symbols, electrical units.....	70
Lighting plant, farm.....	341
shoestring for, display.....	596
standards for.....	62
switches, See Lamp switches	
Liquid flow meter, Venturi.....	288
pressures.....	288
Line starters	
a-c, magnetic.....	246-47, 249-53, 277 281
manual.....	280
d-c.....	149
Local battery telephone.....	51-52
Locator, radio interference.....	521-24
Loftin-White radio circuit.....	394
Longitude, time relation to.....	485
Loud speakers, see <i>Speakers, radio</i>	
Low side float.....	303-4
troubles with.....	305

M

Machines, water soaked,	
treatment of.....	599-600
Magic eye tuning indicator.....	419
Magnet charger.....	342
Magnetic blowout, action of.....	147
controller, d-c motor.....	154-55
relays, see <i>Relays</i>	
starter, a-c, principle of.....	246
auto-transformer.....	259-60, 265-66,
269-71, 276, 278	
line, a-c.....	247, 249-53, 277, 281
d-c.....	149
Magneto, high tension.....	349
inductor.....	350
rotating magnet.....	350
testing of.....	352
testing with.....	27
Wico.....	351
Maintenance, jobs in.....	597-98
Manifold vacuum tests, automobile	
engine.....	369

Subject	Page
Manual starter, auto-	
transformer.....	261-64, 277
line, a-c.....	280
Marine transmitters.....	477-81

Meters

armature tests with.....	117-18
current, testing with.....	29
field coil tests with.....	118
house, circuits in.....	65
ohm, testing with.....	29
output, radio, connections.....	505
radio testing types.....	494
socket type.....	66
Venturi flow type.....	288
volt-ohm-milliammeter.....	494
volt, testing with.....	27
Methyl chloride, temperatures and	
pressures for.....	319
Microphones.....	440, 578
Milliammeter, testing with.....	29
volt-ohmmeter.....	494
Mixers, public address.....	444
transmitter.....	469
Modulation, amplitude.....	468
frequency.....	414-18, 468
principles.....	468
Monitor, transmitter.....	470

Motors

a-c, applications of.....	90-91
capacitor, see <i>Motors, capacitor</i>	
polyphase, see <i>Motors, polyphase</i>	
repulsion-induction.....	241
repulsion start.....	213, 239-40
shaded pole.....	213, 242-43
single-phase.....	213
(See also, <i>Motors, capacitor,</i>	
<i>repulsion-induction, repul-</i>	
<i>sion start, shaded pole, and</i>	
<i>split-phase</i>)	
slip ring, see <i>Motors, wound</i>	
rotor	
split-phase, see <i>Motors, split-</i>	
phase	
squirrel cage, uses of.....	90-91
two-voltage.....	200-202
types and uses of.....	90-91
wound rotor, see <i>Motors, wound</i>	
rotor	
brushes for, setting and fitting.....	85
capacitor.....	220-38
multi-speed.....	230, 232
principle of.....	221
reversible.....	223-26, 230, 232-38
clock.....	212
control, a-c, jogging.....	273
phototube for.....	254, 271
reversing.....	276, 280-81
speed, three-phase.....	278-79
wound rotor.....	207
control, d-c, circuits for.....	123-26
drum.....	137-41
dynamic braking.....	126
printing press.....	136
remote.....	47
speed.....	93, 128, 153
d-c, action of.....	74
applications of.....	90-91
compound wound.....	80
connection diagrams.....	82
construction.....	83
field protection circuits.....	124-25
interpoles for.....	75
maintenance of.....	86
poles of.....	74
principles of.....	76
rotation of.....	74, 76
series wound.....	79, 82
shunt wound.....	78, 82
troubles and remedies.....	86
types and uses of.....	90-91
welding generator from.....	608-9
farm applications of.....	244-45
induction, see <i>Induction motors</i>	
insulation tests on.....	119

(Continued)

Subject	Page
MOTORS (Cont.)	
jogging controls for.....	273
plugging switch for.....	273
polyphase, principles.....	189
speed control for.....	278-79
Prony brake test for.....	77, 132
pulleys, sizes and speeds.....	245
repulsion-induction.....	241
repulsion start.....	213, 239-40
shaded pole.....	213, 242-43
single-phase.....	213
(See also, <i>Motors, capacitor,</i>	
<i>repulsion-induction, repulsion</i>	
<i>start, shaded pole and split-</i>	
<i>phase</i>)	
slip ring, see <i>Motor, wound rotor</i>	
split-phase.....	213-16
connections for.....	217-19
reversing.....	217
squirrel cage, uses of.....	90-91
starters, see <i>Starters, motor</i>	
starting, automotive.....	346
synchronous, ratings of.....	211
revolving armature.....	208-9
revolving field.....	210
small.....	212
speeds.....	208
two-voltage.....	200-202
types and uses.....	90-91
universal, series type.....	81
wound rotor.....	206-7
drum controller for.....	282-84
speed control.....	264, 282-84
Motorola radio receivers.....	541-49
Moving coil microphone.....	440
iron meter.....	171
N	
Neutralizer, ground.....	184
O	
Ohmmeter.....	494
testing with.....	29
Ohm's law.....	384
a-c circuits.....	165
Oil charging, refrigeration.....	335
Oiler, ring.....	292
Open circuits, locating.....	17-20
Oscillation, principle of.....	380
Oscillator, sweep circuit.....	506
transmitter.....	467
Oscillograph, cathode-ray.....	506
aligning receiver with.....	507
Output meter, radio, connection.....	505
Overload relay, thermal.....	247
P	
Panels, distribution.....	182
Parallel circuits, tests on.....	31
resonance.....	379
Paralleling generators, a-c.....	167, 170
d-c.....	94
transformers, three-phase.....	178
Pentode tube.....	391
Phasing, generators, a-c.....	167, 170
speakers, radio.....	398-400
transformers, three-phase.....	178
Philco dynamic tester.....	519-20
radio receivers.....	550-52
Phonograph pickup, crystal.....	425-27
radio, service on.....	425-30
Photoconductive cell.....	452
Photoemissive cell, see <i>Phototube</i>	
Phototube, applications of.....	452
burglar alarm.....	457
motor control by.....	254, 271
relays.....	452-54, 456
construction of.....	454-55
Photovoltaic cell.....	452
Pickup, phonograph, crystal.....	425-27
Picture tube, television.....	464
sound.....	448-51
Plate circuits, radio tube.....	392
Player, record, wireless.....	427
Plugging switch, motor control.....	273
Polarized bell, a-c.....	53

Subject	Page
Polarizing of transformers.....	178
Polyphase motors, principle.....	189
speed control of.....	278-79
Pony relay.....	45
Position indicators.....	188

Power

a-c circuits.....	174
detector, radio.....	394
factor correction.....	163, 176
radio condenser.....	384
pack, insulation tester.....	120
public address.....	441
radio receiver.....	392, 402
relays, circuits for.....	248
requirements, formulas for.....	162
three-phase, measurement of.....	172
transformer, radio.....	404
unit, transmitter.....	472
Pressure balancing, refrigeration.....	332
control, refrigeration, settings.....	308
Pressures, liquid.....	288
refrigeration, settings.....	318
Printing press controller.....	136
Progressive lap winding.....	101-4
Projector, recorded sound.....	451
Prony brake tests, motor.....	77, 132
Public address amplifiers.....	441, 443, 445-47, 453
input circuits.....	444
mixers.....	444
Pulleys, motor, sizes and speeds.....	245
variable speed.....	289
Purging of air, refrigeration.....	326, 332
Push-pull amplifier.....	395

Q

Q factor, coil or condenser.....	384
----------------------------------	-----

R

Radio.....	371-563
automobile, installation.....	432-33
interference in.....	433
code signals.....	482-83
dictionary.....	566-90
interference locator.....	521-24
phonograph, service on.....	425-30
principles of.....	371, 374
receiver, see <i>Receiver, radio</i>	
receiver diagrams.....	
Crosley.....	525
Emerson.....	526-31
Farnsworth.....	532-36
General Electric.....	537-40
Motorola.....	541-49
Philco.....	550-52
Stewart-Warner.....	553
Wards.....	556
Wells-Gardner.....	557-58
Westinghouse.....	554-56, 559-61
Zenith.....	562-63
symbols.....	373, 591
testing.....	493, 496-97, 519-20
transmission.....	467-85
troubles.....	489-90, 493
analyzer for.....	503
tube testing.....	511-18
Radiotelegraph codes.....	482-83
Railway crossing alarm.....	47
Range, electric, circuits of.....	64
REA wiring tests.....	67
Reactance, capacitive.....	164, 377
coil.....	384
condenser.....	384
inductive.....	164, 377
principles of.....	377
resistance with, formulas.....	162

Receiver, radio

aligning, oscilloscope for.....	507
without signal generator.....	508-9
analyzer use with.....	503
analyzing, meter for.....	510
multi-channel.....	412
regenerative.....	405

(Continued)

Subject	Page
RECEIVER, RADIO (Cont.)	
superheterodyne.....	407-8
aligning.....	504
continuous wave.....	484
testing methods.....	493, 496-97, 519-20
three-band.....	412
tuned radio frequency.....	406, 410-11
telephone, testing with.....	29
television.....	463
Reception, radio, principles of.....	371
Reciprocating compressor, refrigeration.....	301
Record players, wireless.....	427
Recording, sound.....	448-51
amplifier for.....	450
projectors for.....	451
Rectifiers, copper oxide.....	401
mercury arc.....	173
tube.....	401
Tungar.....	173

Refrigerants

characteristics of.....	330
charging.....	326-31
dehydrators for.....	336
discharging.....	326
kinds used.....	338
latent heats of.....	330
leak tests for.....	330
pressure-temperature relation.....	319
transfer of.....	329
Refrigeration.....	295-340
absorption system.....	322-25
commercial.....	340
control, settings for.....	318
cycle, commercial unit.....	311
pressure control, settings.....	308
service tools.....	339
valves.....	320
symbols for.....	295
troubles.....	296, 305, 310, 313
vacuum system.....	316
Refrigerators, commercial.....	311
ice cream freezing.....	317
parts of, principal.....	300
refrigerants used in.....	338
two-temperature.....	298
Regenerative receiver, radio.....	405
Regulators, automotive generator.....	356-59

Relays

action of.....	45
applications of.....	47
jogging, motor control.....	273
phototube, circuits for.....	452-54, 456
construction of.....	454-55
power, circuits for.....	248
thermal overload.....	247
time-delay, clock type.....	275
types of.....	45
wiring of.....	46
Remote control, motor.....	47
Repulsion-induction motor.....	241
start motor.....	213, 239-40

Resistance

coupled amplifier.....	395
formulas for.....	381
high, tests for.....	20
reactance with, formulas.....	162
starters, a-c motor.....	255-59
tester for.....	120
tests, motor and generator.....	119
radio receiver.....	496-97
Resistors, color codes for.....	499, 590
Resonance, double hump.....	381
formulas for.....	381
mechanical.....	380
parallel.....	379
principles of.....	379-82
series.....	379
Restrictor refrigeration control.....	312
Retrospective lap winding.....	101-4
Reversing control, motor, a-c.....	276, 280-81
dynamic braking.....	126

Subject	Page
Revolving armature synchronous motor.....	208-9
conductor, voltage generated in.....	487
field.....	185, 187
synchronous motor.....	210
Rheostats, motor starting (see also, <i>Starters, motor, d-c</i>).....	129-31, 133-35
Ribbon microphone.....	440
Ring, jumping, display.....	287, 595
oiler.....	292
RMA color codes.....	499, 590
Room cooler unit.....	314
Rotary compressors.....	301
Rotating magnet magneto.....	350

S

Scanning, television.....	459
disc for.....	465
Schematic diagrams, meaning of.....	35
Screen grid tube, principle of.....	391
Self-synchronous devices.....	188, 285-86
Selsyn controls and indicators.....	188, 285-86
Series circuit, impedance of.....	165
resonance.....	379
wound generator, welding.....	95
motor, d-c.....	79
motor, universal.....	81
Service drums, refrigerant.....	329
electrical, jobs in.....	597-98
refrigeration, tools for.....	339
valves, refrigeration.....	320
Shaded pole motors.....	213, 242-43
Shaft seal, bellows.....	301
Shipboard radio transmitters.....	477-81
Shoe string, lighting, display.....	596
Short circuits, kinds of.....	15
locating.....	20-22
Shunt wound generator.....	92
motor.....	78
Signal generator, calibration check.....	509
Simplex lap windings.....	102-5
Sine curve, development.....	488
wave.....	161
Sines, table of.....	161
Single-phase motors, 213 (See also, <i>Motors, capacitor, repulsion-induction, repulsion start, shaded pole and split-phase</i>).....	292
Sleeve bearings.....	292
Slip ring motor, see <i>Motors, wound rotor</i>	
Socket type meter.....	66
Solenoid starter, a-c motor.....	147
Sound absorption coefficients.....	439
pictures.....	448-51
principles.....	436-39
recording.....	448-51
amplifier.....	450
projector.....	451
wavelengths.....	437
volume.....	439
Spare time job plans.....	593-612
Spark transmitter.....	477
Speakers, radio	
baffle sizes for.....	397
extra, connections of.....	396
fields, power for.....	396
phasing of.....	398-400
types of.....	502
Speed control, motor, d-c.....	93, 128, 153
polyphase.....	278-79
wound rotor.....	207, 264
variable, pulleys for.....	289
Split-phase motors.....	213-16
connections.....	217-19
reversing.....	217
Spot welder transformer.....	183
Square D controls.....	149, 151-52, 248, 252-53, 258-59, 264, 274, 280-81
Squirrel cage motor, revolving field of.....	185
uses of.....	90-91
Star-delta motor starter.....	272
Starters, automotive, testing.....	366-67

Subject	Page
Starters, motor (See also Controllers)	
a-c auto-transformer, magnetic	
259-60, 265-66, 269-71, 276, 278	
manual	261-64, 277
carbon pile	255-56
line, development of	246
magnetic	247, 249-53, 277, 281
manual	280
phototube control for	254, 271
resistance type	255-59
reversing	276, 280-81
star-delta type	272
d-c	123-55
carbon pile	148
circuits for	123-26
line	149
magnetic	149
resistance	127, 129-31, 133-35
reversing	151
solenoid	147
time-limit	150-52
Starting motor, automotive	346
Static, radio	390
Stator windings, connections of	186
consequent pole	196-97
lap	190-95
lap and wave	198
split-phase motor	216
three-phase wave	199
Step-down control, automotive generator	356-57
Stewart-Warner radio receivers	553
Storage battery, cadmium test of	365
high-rate discharge test of	370
Stove, electric, circuits of	64
Sulphur dioxide temperatures and pressures for	319
Superheterodyne receivers	407-8
aligning	504
continuous wave	484
principles of	409
Sweep oscillator	506
Switches	
double-pole, uses of	55
electroliter, uses of	55
four-way lamp control	55-57
lighting uses of	55-57
plugging, motor	273
refrigeration control	307
single-pole, uses of	55
terminals, identifying	41
three-way lamp control	55-57
time, clock type	275
Switchboard, a-c, circuits	168
d-c, circuits	156
Symbols, letter, electrical units	70
radio	373, 591
refrigeration	295
wiring, general	39-40, 54
line diagram	122
meanings of	33-35
Synchronous motors, ratings of	211
revolving armature	208-9
field	210
sma ¹	212
speeds, motor	208
Synchronizing, a-c generator	167, 170

T

Telephone receiver, tests with	29
Telephones, action, elementary	53
central energy	52
local battery	51-52
Television	458-66
camera tube	461-62
Iconoscope	461-62
Kinescope	464
mechanical system	465-66
picture tube	464
principles of	458-60
receiver	463
signal, standard	460
Temperature control, refrigeration	307
resistance determination of	162

Subject	Page
Tesla coil	180
Testers, circuit	17, 25-31
condenser	502
insulation	120
lamps used for	25
wiring	67

Testing

armature, growler method of	116
growler construction	115
meter method of	117-18
circuit	15-24, 42
grounds, accidental	22
high-resistance points	20
insulation, motor and generator	119
open circuit	17-20
radio receiver, analyzer for	503
methods for	510, 519-20
radio tube characteristics	511-18
short circuits	20-22
Thermal overload relay	247
Thermostat, air conditioner with	315
refrigeration control	307
Thermostatic control settings	318
expansion valve	306
Third brush generator, automotive	347
Three-phase power measurement	172
-way switch, uses of	55-56
Time-delay relay, clock type	275
limit starter, d-c motor	150-52
longitude relation to	485
switch, clock type	275
Timing, ignition, method of	355
Transceiver, radio	413

Transformers

action of	49
connections for	49, 179
multi-voltage	50
radio amplifier coupling	395
power type	404
tapped winding	50
three-phase, phasing out	178
paralleling	178
polarizing	178
welding	183
Transmission, power, system for	181
radio, applications	467-85
principles of	371
Transmitter, arc	480
broadcast	474
continuous wave	475-76
-receiver unit	413
shipboard	477-81
spark	477
Trigonometric functions, table	161
Triplex lap winding	105
Troubles, locating, methods of	13-32
motor, d-c	86
probable, determining	31
radio	489-90, 493, 503
refrigeration	296, 305, 310, 313
testers for, see <i>Testers</i>	
testing method for, see <i>Testing</i>	
Tube, ballast, radio	431
capillary, refrigeration	312
radio, characteristics	511-18
pentode	391
principles	391
screen grid	391
Tuned radio frequency receiver	406, 410-11
Tuning, automatic, radio	420-24
indicator tube	419
Two-cycle engines	363
-rate control, auto generator	356-57
-temperature refrigerator	298
-voltage motors, a-c	200-202

U

Universal motor, series type	81
------------------------------	----

V

Vacuum refrigeration	316
tests, automotive engine	369
tube principles	391

Subject	Page
Valves, refrigeration	
compressor, tests of	324
expansion	306
service	320
Variable voltage motor control	93
Venturi flow meter	288
Vibrating controls, auto generator	356, 358
Vibrators, auto radio	434
testers for	435
Voltage doubler rectifier	401
drops, d-c circuit	491-92
examples of	44
experiment with	43
generation, revolving conductor	487
tests, auto electric system	366-67
Voltmeter, moving iron type	171
testing with	27
Volt-ohm-milliammeter	494
Volume control, automatic	419
indicator, transmitter	470
formulas for	162
sound	439

W

Ward's radio receiver	556
Water soaked machines, treatment of	599-600
Wattmeter, indicating	121
integrating	121
power measurement with	172
Wave, sine, development of	488
windings, armature	104, 107-9
Wavelength, sound	437
Welding, arc	159, 604-6
generator, d-c motor for	608-9
series type	95
transformers	183
Wells-Gardner radio receivers	557-58
Western Union relay	45
Westinghouse controls	262
radio receivers	554-55, 559-61
Wet machines, treatment of	599-600
Wico magneto	351
Wind driven generator	486, 601-3

Windings

armature, automotive generator	607-8
coil forming for	112-13
data sheet for	110
equalizers for	110
lap	100-106
materials for	114
tools for	114
wave	104, 107-9
stator, connections of	186
consequent pole, three-phase	196-97
lap	190-95
lap and wave	198
split-phase motor	216
three-phase lap	190, 192-95
three-phase wave	199
two-phase lap	191
Wireless record players	427

Wiring

building, diagrams of	61, 63
symbols for	54
tests of	25, 67
bungalow	58-61
diagrams, kinds of	35
meaning of	35
reading of	36, 590-91
specifications, typical	58
symbols for	39-40, 54
line diagram	122
meanings of	33-35
Wound rotor motors	206-7
drum controller for	282-84
speed control of	264, 282-84
starter for	259

Z

Zenith radio receivers	562-62
------------------------	--------

ACKNOWLEDGMENTS

Through our close cooperation with the Electrical and Radio industry for over 40 years we have received invaluable assistance in preparing the material for this Manual. We wish to acknowledge our sincere appreciation to the following companies for their help in supplying data, illustrations and material for the preparation of the Coyne Trouble Shooting Manual:

General Electric Co.
Westinghouse Elec. Mfg. Co.
Cutler Hammer Mfg. Co.
Allis Chalmers.Mfg. Co.
Louis Allis Co.
Allen Bradley Co.
Emerson Electric Co.
Delta Star Mfg. Co.
Square D Mfg. Co.
Century Electric Co.
Allied Radio Corp.
P. M. Mallory Co.

Farnsworth Radio &
Television Co.
Emerson Radio Mfg. Co.
Motorola Radio Mfg. Co.
Philco Radio & Television Co.
Stewart-Warner Mfg. Co.
Wells-Gardner Radio Mfg. Co.
Zenith Radio Corp.
Electrical Contracting
Nela Park Laboratories
Western Electric Co.
Crosley Radio Corp.

HOW TO USE THE COYNE ELECTRICAL AND RADIO TROUBLE SHOOTING MANUAL

The Coyne Electrical and Radio Trouble-Shooting Manual is really two books in one. First of all, there is the complete step-by-step Electrical trouble-shooting plan that provides an easy, practical, dependable program for checking any Electrical or Radio trouble on industrial or household equipment. There are many publications that deal with one phase of the subject of Electrical Trouble-Shooting but here for the first time is a complete, carefully field tested program for the location and repair of any Electrical or Radio problems. Many purchasers of the Coyne Electrical and Radio Trouble-Shooting Manual have told us that this section alone was worth many times the cost of the book.

The second portion of this book contains carefully selected shop prints and diagrams of motors, controllers, starters, generators, compensators, transformers and hundreds of other types of Electrical and Radio equipment. It includes actual wiring diagrams of the equipment manufactured by Westinghouse, General Electric, Century, Emerson, Allen Bradley, Allis Chalmers, as well as dozens of other large electrical and radio companies.

Any book to be of maximum benefit to a man learning to read Electrical shop prints or using the book for field reference, must be complete in every possible detail. The Coyne Electrical School has exerted every possible effort to see that this book has a complete set of Electrical and Radio shop prints and wiring diagrams.

The prints and diagrams provide the fellow interested in Electricity with a tremendous advantage as they contain the material to enable him to diagnose and remedy practically any Electrical, Radio, Refrigeration or Automotive Electrical problems in the field. One buyer aptly described this book by saying, "THE COYNE ELECTRICAL AND RADIO TROUBLE-SHOOTING MANUAL IS TO AN ELECTRICIAN WHAT A SET OF LAW BOOKS IS TO A LAWYER—it provides the answer to hundreds of problems in the Electrical field." This book could likewise be compared to a set of medical books for a Doctor. Regardless of whether a Doctor, or a lawyer is just starting his practice or whether he is an "old timer" and has

been in the profession for many years, he has many occasions to refer to his reference books on certain cases in order TO BE SURE. A lawyer will look up some similar case to that upon which he is working, to see what decision was rendered, the same as a Doctor in diagnosing an ailment for a patient, and prescribing the proper treatment, will refer to his books to guide him on the matter.

This same situation prevails in the Electrical and Radio industry. Whenever a man has an important problem to handle involving the installation, care or maintenance of Electrical or Radio equipment, he often needs a reference book to make certain that he has the proper knowledge to proceed with the job.

The shop prints, diagrams, and other material in this book are exactly the same as those used in our shop training courses. Every print has been used by hundreds of men, so it has been tried and tested by actual use.

WE HAVE USED THESE PRINTS AND HAVE ELIMINATED ERRORS FOUND IN PRINTS THAT MAY HAVE BEEN PREPARED IN A HURRY AND HAVEN'T ACTUALLY HAD THE BENEFIT OF ACTUAL FIELD EXPERIENCE IN DETERMINING WHETHER THEY ARE ELECTRICALLY CORRECT. There are many diagrams today that haven't undergone the test of actual shop and field use and which, therefore, stand the possibility of being incorrect. This is a very important point to keep in mind in using the prints in this book; they are ELECTRICALLY CORRECT, because they have been field tested.

ELECTRICAL, RADIO AND ELECTRONIC DICTIONARY OF 1200 TERMS INCLUDED

In preparing the material for the Coyne Electrical and Radio Trouble-Shooting Manual we realized the need of simple explanations of commonly used Electrical, Radio and Electronic terms. We have therefore prepared a 1200 term Electrical and Radio Dictionary as a part of this manual. Electricity and Radio, like any other specialized field of endeavor

have a special "language" for the explanation and discussion of its problems. This language includes words, abbreviations, letters and schematic symbols, each representing an idea or picture. We have found that the "beginner" just by reading this dictionary carefully, a few pages each day, can become surprisingly familiar with the subjects of Electricity and Radio.

We have always felt there was no necessity in going "High Brow," defining Electrical terms, and the more simple the language of Electricity and Radio can be made, the easier it is for anyone to understand it.

In our Electrical and Radio Dictionary, we explain terms and words employed in commercial and industrial applications of Electronic devices and apparatus. All the words, terms and abbreviations are arranged in one continuous alphabetical order. Wherever possible, we have included diagrams of Electrical apparatus or devices. We have found that this helps to enable a "beginner" as well as an "old timer" to more readily understand the definitions. You will note in the dictionary, as well as throughout this entire book, the entire thought in preparing the material was toward making it easy to understand. There is no reason for using three words where one will do the job. We believe that the material as we have prepared it, will make clear many of the Electrical and Radio expressions and afford a more complete understanding of various Electrical and Radio terms, each of which has a very definite meaning. This Electrical Dictionary should enable you to be an authority on the exact meaning of any Electrical or Radio term or expression.

HERE'S HOW YOU CAN BENEFIT FROM COYNE ELECTRICAL AND RADIO TROUBLE-SHOOTER

In preparing this complete Electrical and Radio Trouble-Shooter, and in making these books available to all who are interested in Electricity, we made them easy to understand and practical for the "beginner" as well as the "old timer." The Electrical and Radio shop prints are valuable to anyone learning Electricity or working at it for his living. Suppose we take the Electrician who works at the trade every day. This fellow has a definite need for this book for use in his daily work in handling all types of Electrical Trouble-shooting, maintenance and Electrical installation work. The step-by-step trouble-shooting instruction as well as the section containing over 500 actual wiring diagrams, provide the answer to any Electrical problem.

Then let us consider the helper Electrician. THIS FELLOW WORKS IN A PLANT AND IN MOST CASES, IS AMBITIOUS AND ANXIOUS TO GET AHEAD BUT LACKS THE KNOWLEDGE TO PROGRESS FURTHER IN HIS JOB. These men can make excellent use of the Coyne Electrical and Radio Trouble-Shooting Man-

ual to acquire the knowledge of shop print reading, circuit tracing and step-by-step trouble shooting procedure that is vitally essential for them to know before assuming added responsibilities in their organization.

In fact, in every plant, there are many men who are working at various jobs—other than Electrical work, who see great opportunity in the Electrical department. These plants in most cases, are not Electrical plants, but still depend on Electricity for all production power. As an example, take the Sears Roebuck Company's large plant in Chicago. Here's a plant that does no Electrical manufacturing—it is not known as an Electrical Company and from all outward appearances, would not provide opportunity for Electrical men. However, in this plant alone, which is strictly in the Mail Order Merchandising business, there are dozens of men who are engaged in Electrical work of one type or another. The same thing is true of Textile Mills, Paper Mills, Steel Mills, large office or apartment hotel buildings, Aircraft Plants, Arsenals, Shipyards, etc.

The point that we are trying to bring home is the fact that Electricity and Electrical jobs are on hand all over for the man who is trained to handle them. To handle Electrical jobs, men must know first of all the proper method of locating and repairing Electrical equipment. Secondly, it is vitally essential that they understand shop print reading and circuit tracing. To the man who may be working in one type of occupation and is anxious to get into the Electrical Department of his plant, this course is valuable because it provides an easy, practical way to learn Electrical Trouble-Shooting and Shop Print and Motor Diagram reading in the quickest possible time.

ELECTRICAL AND RADIO WORK

Throughout the length and breadth of this country, there are thousands of men who do Electrical work in their spare time, either as hobby or as a spare time job. The material in this book is especially valuable to a man of this type because it has so many practical shop prints on equipment and wiring done in the average home. As an example, refer to Diagrams No. 61 and 63. Here you will note that we have included the complete wiring of a 5-room house, including all outlets, junction boxes, switches, etc. A shop print of this type is extremely valuable to anyone doing house wiring, whether he plans to wire the entire house, or whether he is merely interested in installing an extra outlet or doing some incidental wiring in a home that is already wired for Electrical power. If a man didn't use the knowledge obtainable from this book in any other way, but to take care of the Electrical work to be done in and around his own home or farm, the book would more than pay for itself many times each year. In fact, many times one little job will more than pay for the cost of this book.

There are many other prints of value to a man working at Electricity or Radio, in his spare time. Some in particular that would be extremely helpful, are in Automotive Electricity. One is shown on page 345 of this book. To realize the value of the investment in the Coyne Electrical and Radio Trouble-Shooting Manual a man doesn't have to use the material every day on a job. **JUST TO BE ABLE TO HAVE IT AVAILABLE FOR EVEN OCCASIONAL REFERENCE, WHERE A MAN WANTS TO BE SURE, BEFORE GOING AHEAD ON SOME ELECTRICAL OR RADIO WORK, MAKES THIS BOOK EXTREMELY VALUABLE.**

Regardless of what kind of work you may be doing—whether you are a “beginner” or an “old timer” in the Electrical or Radio Field, you will find the material we have covered in this book to be of extreme value to you all through life.

We have tried to prepare the greatest amount of up-to-date instruction on the subject of Electrical Trouble-Shooting and have “geared” it to modern industrial and domestic needs. Yet, we have always made the material simple enough so that a fellow who is learning Electricity can readily understand and follow the instructions and information.

IMPORTANT—READ CAREFULLY

HOW TO USE THE COYNE ELECTRICAL AND RADIO TROUBLE SHOOTING MANUAL

There are many ways that this book can be used. To get the maximum benefit from it, we want you to know just how to use this book for whatever purpose you have in mind. If you are an experienced Electrician at work in the field, there is a certain way that you can benefit most by the material in this book. On the other hand, if you are a “beginner,” and interested in learning how to read shop prints and motor diagrams, then there is a definite way that we suggest that YOU study the material in this book. We will try to outline the best plan to follow for you individually, to get the most out of this material.

HOW THE EXPERIENCED ELECTRICIAN USES THE COYNE ELECTRICAL AND RADIO TROUBLE SHOOTER FOR REFERENCE WORK IN THE FIELD.

The experienced Electrician—the fellow who has been “in the game” for some time and is daily working in the field, has a great need for a reliable, authoritative and complete reference book on Electrical Trouble Shooting and Shop Prints and Motor Diagrams. He should have something available at all times to which he can refer with confidence—something that he knows contains material and information given on any motor or Electrical machine that is above all, accurate and dependable. This book fills the need for the Electrician, because it provides him with the material that has been field tested by actual use. We also feel that the material we have prepared for the benefit of the “beginner” or the fellow interested in learning how to read shop prints, would be of equal advantage to the “old timer” as well.

THE ELECTRICIAN'S JOB IS TO “KEEP 'EM ROLLING”

In every plant, there are Electrical motors, controllers, switches, starters, meters and dozens of

other pieces of Electrical apparatus. The job of the Electrician is to keep the equipment operating and to get the greatest possible service out of it. The more information he has on his company's equipment, the more valuable he can be to his organization on his job. Now here's how the experienced Electrician can get the most out of this book.

DETAILED INDEX PROVIDES EASY WAY TO LOCATE THE PRINTS YOU WANT

To begin with, we have spent a great deal of time in preparing a complete simplified index for this book that will enable you to get the utmost value from it. This index is detailed and cross referenced in every possible respect. We want every man, and particularly the Electrician on the job, to be able to FIND THE SHOP PRINTS AND THE INFORMATION HE WANTS EASILY. That is why we have provided an index that would enable anyone in a few seconds, to locate any information he may want at any time.

PREPARE FOR A BIGGER PAY JOB

The important thing to consider as you go over the material and shop prints in this book is the fact that regardless of size or make the PRINCIPLES of ELECTRICITY apply on ALL ELECTRICAL EQUIPMENT. In most plants there are many motors, controllers, starters, transformers, etc., ranging from fractional horse power up to possibly several hundreds or thousands of horse power per unit. Now the Electrical principles embodied in the smallest motor are also the same in the largest motors. So, to the man employed as an Electrician, we suggest that he prepare in advance for the handling of more responsible Electrical jobs by studying ALL the diagrams and other material in this book. A very wise man once said, “The secret of success is to PREPARE TODAY FOR TOMORROW.” This Trouble Shooting Manual en-

ables you to **PREPARE NOW** for additional responsibility **TOMORROW**.

A study of the shop prints and the "step by step" practical trouble shooting program covered in this book will provide the necessary training for the job ahead and will also act as a guide to your knowledge of various phases of your trade.

IF YOU ARE DOING ELECTRICAL WORK, KEEP YOUR COYNE TROUBLE-SHOOTER ON THE JOB

Many Electricians take the Coyne Electrical and Radio Trouble-Shooting Manual to the plant in which they work, to keep it handy for **immediate reference**. Many things happen to Electrical equipment and very often a man needs a diagram or a shop print to help him trace the trouble. This book will be worth its weight in gold many times over, **if you let it work for you**.

At this point, we'd like to cover a very important feature regarding the material and its form of presentation in this book. **We have found through years of experience that shop prints printed in black on white paper, with a space around the print, for special notations and comments, are more valuable and practical for the beginner and the experienced electrician.** Practically anyone using these prints makes notes on them and it is easy to understand that print on white paper is far better for this purpose. This is particularly true in tracing circuits where various colors are used to designate different circuits. **Therefore, we thought it greatly to the advantage of the user of the set, of these shop prints, to have them printed in black on white paper.**

HOW THE ELECTRICAL HELPER OR BEGINNER USES THIS BOOK

One of the questions the average fellow starting out to learn how to read shop prints, asks himself is:

"What education do I need to understand the reading of shop prints as used in the Electrical and Radio industry?" We have made these prints practical and easy to understand so that **anyone should have no difficulty with them**. All that you have to do, is to understand a few simple rules and symbols. Shop Print reading, (once these few simple things are understood), is just as easy as reading a newspaper or a book. There is an old Chinese proverb which reads, "One picture tells the story of 10,000 words." It is conceivable then that one shop print can tell the story of 5,000 words. You see the basic principle of any shop print or diagram, is to tell a complete story by the use of lines and symbols that might otherwise require thousands of words of explanation.

One thing about shop print reading that is significant is the fact that there are many branches

of this "sign writing" that you have probably already used from early childhood without being conscious of the fact. As you make a study of circuit tracing and shop print reading in this book, you will readily note this.

Although each section of the shop print book has complete explanatory instructions, we'd like to illustrate at this time how very simple the tracing of circuits and motor diagrams can be. To do this, let us use a common, every-day illustration that brings home a basic, elementary lesson.

The explanation we shall use, has nothing to do with Electricity, but it provides a very simple explanation of a **diagram**.

You have often heard the expression of baseball—"A CIRCUIT CLOUT"—that means a home run or a drive that has completed the **circuit of bases**. What actually happens when a home run is hit, is that a fellow hits the ball so far that he can complete the circuit of bases before the ball is returned.

Here's another example of a simple "LINE PICTURE." Suppose you wanted to explain to someone just how a baseball field was laid out. The easiest way to illustrate this would be to draw a diagram of a baseball field, such as we have indicated below. Then to indicate how baseball is played, you would place arrows indicating the progress around the bases in scoring a run. Your **DIAGRAM** or "Line Picture" would look like this:

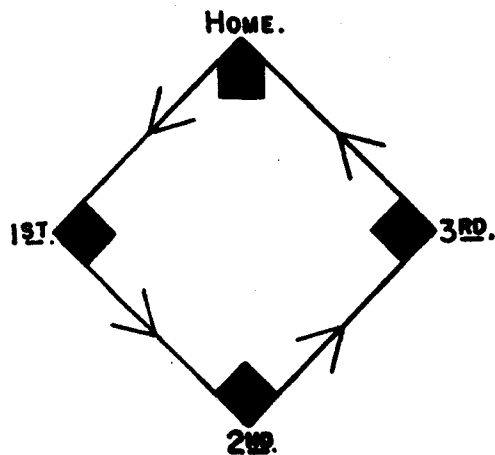

Now these are simple illustrations to give you an idea of **DIAGRAMS**. You can readily see that you don't need any advanced education to follow these simple instructions and that you have already actually drawn many diagrams or "line pictures" during your lifetime. If you will keep the thought in mind at all times that a diagram is always intended to simplify the explanation of any Electrical machinery or principle, you should have no trouble in understanding the shop prints in this book. These preliminary instructions as well as the detailed explanation in each section of the shop prints, will provide you with all the instructions you should



Fig. 1. Parts for a simple battery operated door bell.

need to thoroughly understand wiring prints for Electrical and Radio apparatus.

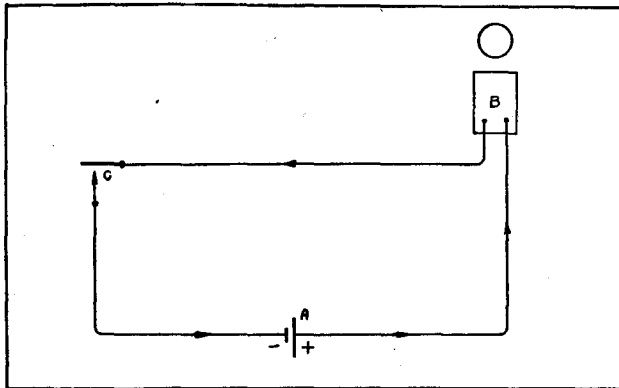

Fig. 2. Wiring diagram of equipment pictured in Figure 1.

USE OF PLANS AND SYMBOLS

When equipment for any signal system is **PIC-TURED** as in Figure 1, it is of course, easy to recognize each part and also to connect the wires as shown. But we must have some form of plan or sketch, from which to do such work and the plan must be made more quickly and cheaply, than a photograph. So instead of having actual pictures of the equipment, various symbols are used to designate different types of materials that go into any wiring job. The various symbols that are used, are discussed in detail in another section of this book. At this point, however, we'd like to give you some preliminary instruction in the very simple door bell wiring job. In Figure 1, we have shown by way of photographs, the various equipment in a simple battery operated doorbell signal system. In Figure 2, is shown a simple sketch of the same doorbell system, as in Figure 1.

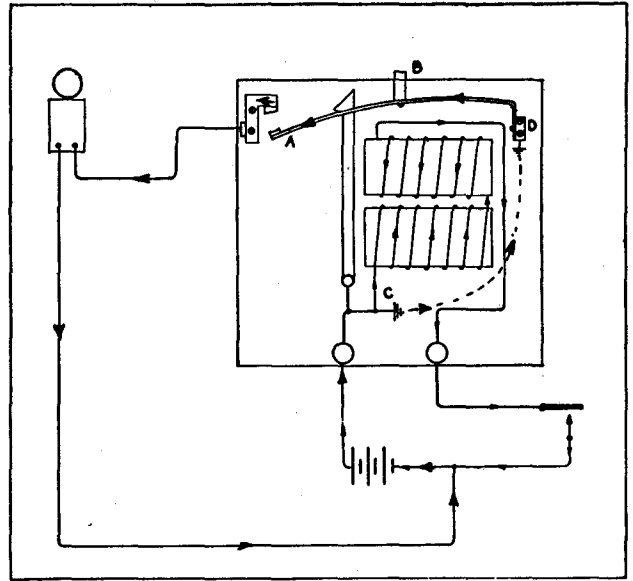

Fig. 3. Connections for drop relay.

This sketch, uses symbols for the various parts and can be quickly and easily made and also easily understood with a knowledge of the various symbols designating the equipment on this wiring job.

The part marked "A" is the symbol for a cell, or battery the long line representing the positive terminal at which the current leaves, and the short line the negative terminal. "B" is the symbol for the bell and "C" is the symbol for the switch.

The heavy top line of the switch represents the movable contact. The arrow underneath represents the stationary contact. Note that the arrow does not touch the upper part, showing that the switch is open as it should be normally. Imagine that you were to press down this top part causing it to touch the arrow and close the circuit (that is like pressing the button in Figure 1). Current would immediately start to flow from the positive cell to the bell, and back to the switch, to the negative side of the cell. The arrows along the straight line representing wires, show the direction of the current flow.

This illustration is given so that you will understand in reading any Electrical diagrams in this book that the current flow should always be traced out in this manner.

TRACING CIRCUITS IN DROP RELAYS AND CONSTANT RINGING SIGNALS

In certain alarm and signal systems it is often an advantage to have the bell continue to ring until it is shut off by the person it is to call. For example a burglar alarm, in order to give a sure warning, should not stop ringing if the burglar stepped in through the window and then closed the window quickly. To provide continuous ringing of a bell, once the switch is closed, we use a device called a drop relay. Figure 3 shows a sketch of the connections of a drop relay with a bell, battery

and switch, ready to operate. Study each part of this circuit and examine the parts of the device carefully, and its operation will be easily understood.

When the switch is closed, current first flows through the circuit as shown by the small arrows, causing the coils to become magnetized and to attract the armature. This releases the contact spring which flies up and closes the circuit through the stationary contact to the bell. Before being tripped, the contact spring is held down by a hook on the armature, which projects through a slot in the spring. The button "B" extends through the cover of the relay, being used to push the contact spring back in place, or reset it, and to stop the bell from ringing.

In tracing the bell-operating circuit, shown by the large black arrows, we find that the current flows through the frame of the device from "C" to "D." The marks or little group of tapered lines at "C" and "D" are symbols for GROUND connections. From this we see that a ground connection as used in Electrical work does not always have to be to the earth. Instead, a wire may be GROUNDED to the metal frame of any electrical device, allowing the current to flow through the frame, thus saving one or more pieces of wire and simplifying connections in many cases. This is a very common practice in low voltage systems and is extensively used in telephone and automobile wiring.

It is not our intention in these preliminary instructions, to go into detail concerning the tracing of circuits and diagrams. We merely wanted to present these explanations to illustrate how comparatively simple the subject, "Shop Prints and Motor Diagrams" reading is for anyone who has an interest in the subject.

Electrical shop print reading is the same as any other reading—the more you do of it, the more efficient you become. The **Coyne Electrical Shop Prints** in this book are especially valuable to you because they not only have the actual motor diagrams, but also carry valuable explanatory material. In going over any material in this book, if you do not get the thought immediately, go over it again and again until you thoroughly understand it. Remember that any Electrician or any man who hopes to hold a responsible Electrical job **MUST DEFINITELY KNOW AND UNDERSTAND SHOP PRINTS, DIAGRAMS, CIRCUIT TRACING, ETC.** It is as vitally essential to know these things, as it is to actually know the motors and Electrical equipment you work on, because the knowledge of these things provides a source for "short cuts" to trouble shooting and fault location in improperly operating Electrical equipment.

USE SPARE TIME JOB LESSONS TO EARN EXTRA MONEY

Another valuable feature of the **Coyne Electrical and Radio Trouble-Shooting Manual** (and one of the things that will make the book pay for itself), are the spare time job lessons, located at the **back end of the book.** I'd like to explain just how we prepared these special lessons, and how they can mean extra money to you.

It has often been said, "Time is the most precious thing in the world." **EVERY ONE IS GIVEN A CERTAIN AMOUNT OF TIME AND HOW HE MAKES USE OF IT, REGULATES IN A LARGE MEASURE THE SUCCESS HE ENJOYS IN LIFE.** Electricity and Radio offer tremendous opportunities for a man to utilize his spare time to make some extra money. There are many ideas that can be used that would provide a regular income for anyone who is willing to devote a few hours each day or week to the development of various Electrical Service programs.

The purpose of our spare time job lessons is to explain some of these ideas, that have been used by thousands, that have proven "Real money makers." In most cases there is very little capital needed to start these plans and in practically every case the service offered on the program is something that **should be needed in any community.** Here are some of the subjects in our Spare Time Job Lessons that we have prepared in detail for you beginning on page 591 of this book.

Spare time Job Plan No. 1—**HOME MODERNIZATION**—Extra outlets, illuminated house numbers, new modern lighting fixtures. Replacing worn appliances and lamp cords.

Spare Time Job Plan No. 2—**FREE ELECTRIC POWER FROM WIND-DRIVEN POWER PLANTS.**

Spare Time Job Plan No. 3—**ELECTRIC ADVERTISING DEVICES**—Introducing new and novel advertising methods in your locality.

Spare Time Job Plan No. 4—**ELECTRICAL MAINTENANCE CONTRACTING AS A SPARE TIME BUSINESS.**

Spare Time Job Plan No. 5—**ELECTRICAL WELDING OPPORTUNITIES FOR FULL OR SPARE TIME JOBS.**

Spare Time Job Plan No. 6—**AUTO IGNITION AND AUTO ELECTRIC SERVICE PLAN**

Spare Time Job Plan No. 7—**ADAPTING INDUCTION MOTORS TO NEW OPERATING CONDITIONS.**

Any one of these plans can provide a fine income for a man who is willing to devote a little time in preparing his program and selling it to his locality.

If there wasn't enough of work of any one of these particular plans, certainly all of them combined could provide a splendid source of additional income every year.

You will notice in our explanation of these plans, that we give specific instructions not only on how to do the work, but in addition, how to "sell" the ideas. I'd like to make it quite clear that you don't have to be a salesman to put these ideas across because the service is so vitally essential that it actually "sells itself."

We included these special Spare Time Job Plans as just another way of **having this valuable shop print book pay for itself.**

In concluding this introductory material, we'd like to leave this thought with you. Although the Coyne Electrical and Radio Trouble-Shooting Manual can be valuable to you almost every day on the job, nevertheless if you used this **only occasionally for important Electrical or Radio problems**

and even one particular occasion might more than pay for the book. The value of a book isn't always regulated by how often you use it, but rather **how important and how valuable it can be WHEN YOU NEED IT.** This book can be the most valuable book you have ever owned because it will provide the help you need **WHEN YOU NEED IT.** Remember, if it pays a Doctor or a lawyer to spend **hundreds of dollars on reference books,** so that **HE CAN BE SURE** of his steps in important cases, it is equally important for the Electrician or the man aspiring to a good electrical job, **to have his reference books for important problems that come up in his work.** An investment, therefore, in a book of this type is an investment in your future success.

H. C. LEWIS, President,
Coyne Electrical School.

FIG. 1.

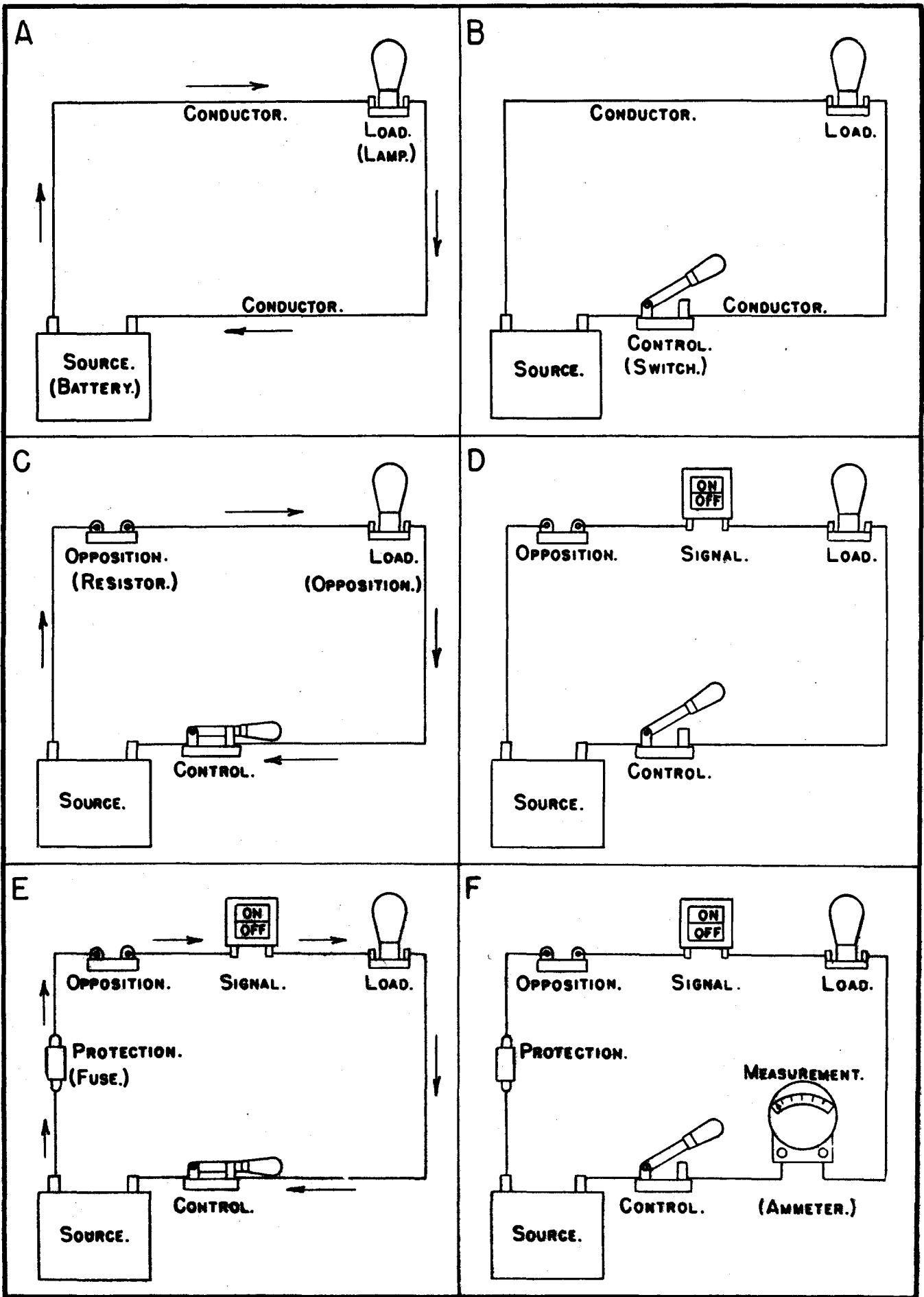

STEP BY STEP METHOD OF ELECTRICAL AND RADIO TROUBLE SHOOTING

Whether it is a door bell or a central power station, every electrical system begins with plans and layouts, followed by installation of the equipment and making of connections that place the system in operation. If every part of the system were then to operate indefinitely without trouble there would be no further work for electrical men. But sooner or later something will go wrong, and then begins the job of trouble shooting.

When electrical equipment fails to operate correctly, and you are called on to fix it, the people who call for help won't be able to tell you what really is wrong or exactly where the trouble lies. They will tell you simply that the motor won't start, that the lamp won't light, that the flat iron won't heat—and from there on it's up to you.

Trouble shooting—determining the kind of trouble and its exact location—usually is considered to be the most difficult of all electrical work. It actually is difficult for most men because they go at the job in a hit or miss fashion, hoping that luck will be with them and that some fortunate twist of a screw or pull on a wire will start things going again. The fact that they do not thus really locate the trouble and its cause means that it will reappear in a short time, which won't help the reputation of the man who "fixed" it.

Like all other problems, trouble shooting can be made much easier and the results more positive and lasting if you work according to definite plans. Working logically and systematically will quickly eliminate one possibility after another until the real fault is found. The first step in working out a trouble shooting system is to investigate electric circuits in general.

We must understand electric circuits because nearly any kind of trouble allows either too much or too little current to flow in the circuit. Trouble shooting is the process of determining whether a circuit will carry too much or too little current, and of interpreting the results of systematic tests so that we may locate the kind of trouble and its position.

THE PARTS OF A CIRCUIT

Electric circuits of the kind we are interested in are paths composed wholly of conductors through which current may flow. At some point in the conductive path is a source of electromotive force or voltage. This force causes current to leave the source, pass through the entire path outside the source, and return to the source. In addition to the source of emf all practical circuits include some kind of load. A load is any equipment in which electric power does useful work. A load may be a

motor which causes mechanical motion, it may be a lamp which produces light, it may be a heater which raises temperatures, or it may be any other of a long list of things which are electrically operated.

A circuit containing the fewest possible parts is shown at "A" in Fig. 1. The source of voltage and current is a battery, the load is a lamp, and between the source and load are wires. Current leaves one terminal of the source, flows to and through the lamp, then returns to the source. At "B" we have added a control, in the form of a switch that allows turning the lamp on and off.

In case the voltage of the battery is so high as to force excessive current overload and possibly burn out the lamp we may add opposition to current flow, the resistor of diagram "C" in Fig. 1. Suppose the lamp is where it cannot be seen when operating the switch, we may add a signal in some other part of the circuit, as at "D." Next, wishing to prevent overheating of devices in our circuit because of excessive current, we add protection in the form of a fuse in diagram "E." Finally, in order to determine just how much current flows in the circuit, we provide measurement by means of the ammeter in diagram "F."

All of the parts in ordinary direct-current circuits may be classified as one of the types that we have used in Fig. 1. To the list we should add insulation, which prevents escape of current and voltage from the conductors, and which frequently acts at the same time as a means of support.

Now let's examine the alternating-current circuit shown by Fig. 2, noting whether we find parts which perform in general the same functions performed by parts in Fig. 1.

First in the a-c circuit we have a source, which is the a-c generator. We have a load which consists of the motor. There are connecting wires and insulation. For control we have an automatic relay that closes the generator circuit only after the generator voltage reaches a value suitable for operating the load. To protect the relay winding against excessive current we have opposition in the form of a resistor. A lamp connected across the generator acts as a signal to show whether the generator is in operation. Protection against overheating of the motor due to overload is furnished by an automatic circuit breaker that opens after excessive current has continued for a predetermined time. Measurement of voltage in the motor circuit is provided with a voltmeter.

In the alternating current circuit of Fig. 2 we have one kind of device not found in the direct-current circuit of Fig. 1, we have a transformer

FIG. 2.

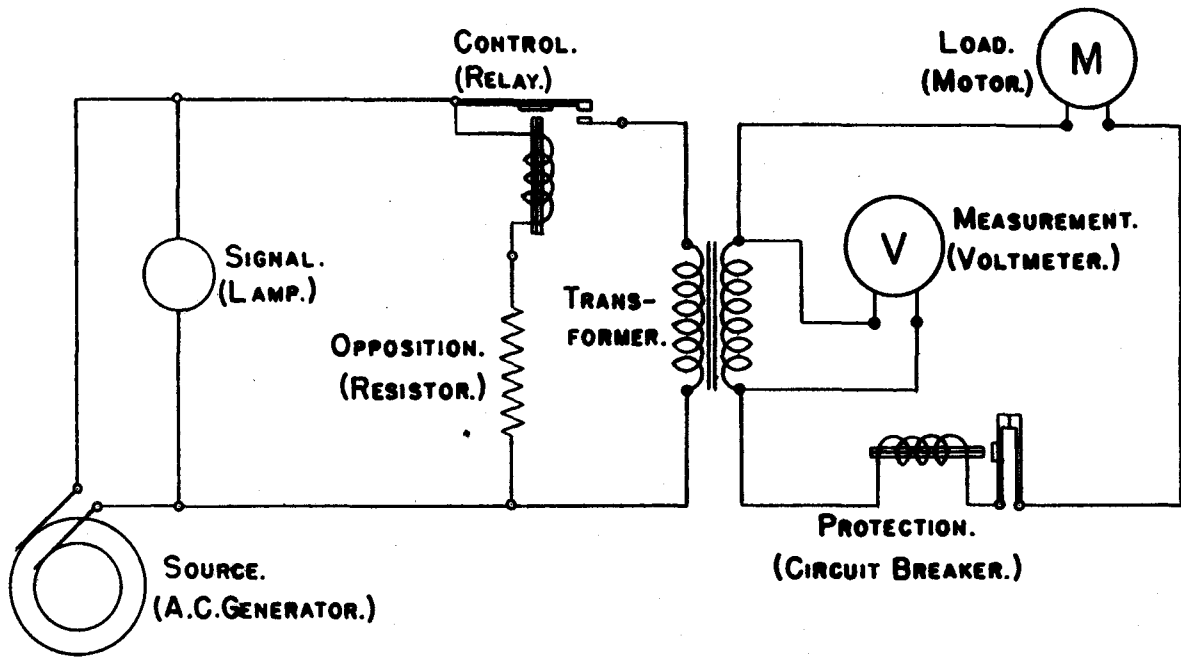

FIG. 3.

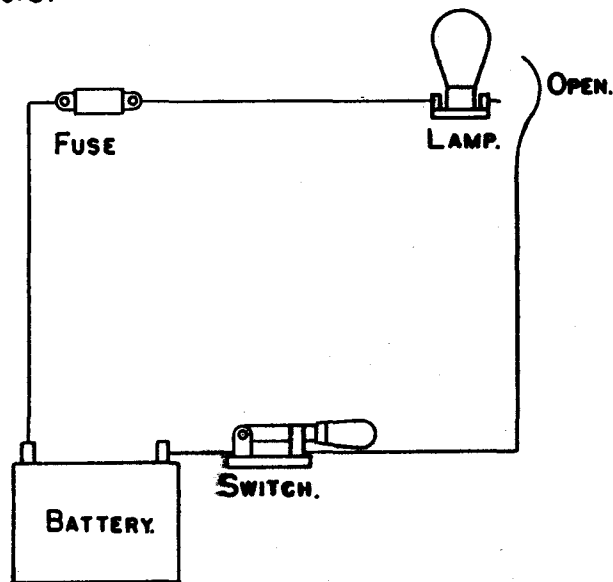
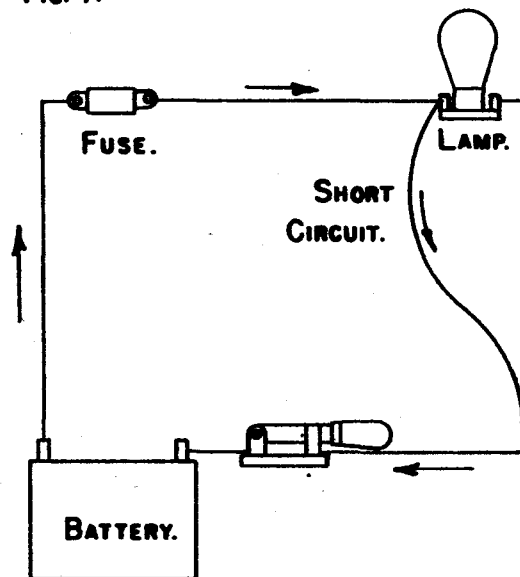

FIG. 4.



that changes the voltage from the generator into a voltage suitable for the motor. This we may classify as translation equipment.

Now we may list as follows all the general classes of equipment found in electric circuits:

1. Sources: Batteries, generators, power lines, thermocouples, etc.
2. Loads: Motors, lamps, heaters and other power-consuming equipment.
3. Conductors: Wires and other metallic and conductive parts for current.
4. Insulation: Often in the form of supports as well as wire coverings.
5. Controls: Switches, relays, starters, controllers and similar devices.
6. Opposition to current flow. Resistors, coils, capacitors, etc.
7. Signals: Lamps, bells, buzzers, annunciators, sounders, etc.
8. Protective devices: Fuses, circuit breakers. Sometimes transformers.
9. Measuring devices: Meters of various types.
10. Translation devices: Chiefly transformers and converters.

The general types of parts just listed may be combined in countless ways to form electric circuits. We may have one or more than one of any of these parts in a circuit. The circuit of Fig. 2 certainly looks entirely unlike those of Fig. 1, yet when we consider the parts according to their functions we have the same general kinds in both cases.

KINDS OF TROUBLE

Just as we classified switches, relays and starters under the one heading of controls, and just as we classified many other devices under some one general heading, so we must classify electrical troubles themselves into groups if we are to develop a workable system of trouble shooting.

Considering individual or particular electrical troubles we might have a burned out lamp, a burned out resistor, a blown fuse, a disconnected wire, a sticking contactor, or corroded relay contacts. But in our method of locating faults all these would be classified as open circuits. They would be classified as open circuits because they prevent flow of current in the circuit—from the standpoint of current flow the circuit is open, and when a circuit is open at any point and for any reason no current can flow in any part of that circuit.

We group all these troubles, and many others, together because it is relatively easy to determine when there is an open circuit and then to locate it as existing in some one section of the circuit. Knowing the general class of trouble present, and knowing its approximate position, we simply examine the parts to see which of them is out of order in the one particular manner.

Fig. 3 illustrates an open circuit caused by a wire end disconnected from one side of the lamp-socket or lampholder. Even with the switch closed

no current can flow in any of the conductors of the circuit.

Such things as dirty or corroded contacts and weak springs in automatic switches might not keep the circuit completely open but might introduce abnormally high resistance. The contacts might come together, but instead of making a full and clean connection they might make a connection through only a limited area, and through the dirt and corrosion instead of through clean metal surfaces. Abnormally high resistance, from any cause, is our second general classification of circuit troubles.

An open circuit prevents flow of any current at all. High resistance allows only a relatively small current to flow. These two classes of trouble are somewhat similar in that both reduce the flow of current, and they are identified and located by the same general methods of testing.

SHORT CIRCUITS AND GROUNDS

In Fig. 4 the wire that became disconnected from the lamp socket terminal in Fig. 3 has made contact on the other lamp socket terminal. Now current from the battery flows, as shown by arrows, through the fuse, the accidental connection at the socket terminal, the switch, and back to the battery. The relatively high resistance of the lamp filament no longer is included in the current path, and the current will increase to a very high value. The excessive current will almost instantly blow the fuse. The blown fuse will protect the battery from excessive discharge, but the real trouble still remains and if a new fuse is put in it will blow just like the first one.

Fig. 4 illustrates a short circuit, which is a circuit in which current from the source may flow and return to the source without going through the load. This is our third general class of circuit troubles. A short circuit may result from any one of many particular faults. In our testing method we are able to determine that there is a short circuit, and are able to determine its approximate location in the circuit. After that it is just a case of examining parts at this location for such faults as allow conductors on opposite sides of the circuit to come together.

At "A" in Fig. 5 we have a one-wire circuit or ground-return circuit. Instead of the entire circuit being completed through insulated wires a portion of it between the battery and lamp is completed through any metallic supports or framework that extend from near the battery to near the lamp. A connection to ground is indicated by a symbol consisting of several horizontal lines.

At "B" in Fig. 5 one of the wires has come off the lamp socket and the bare end of the wire has fallen against the metallic ground. Now current from the battery flows, as shown by the arrows, through the fuse and the metallic ground back to the battery—without going through the lamp. As you will recognize, this accidental ground is simply

FIG. 5.

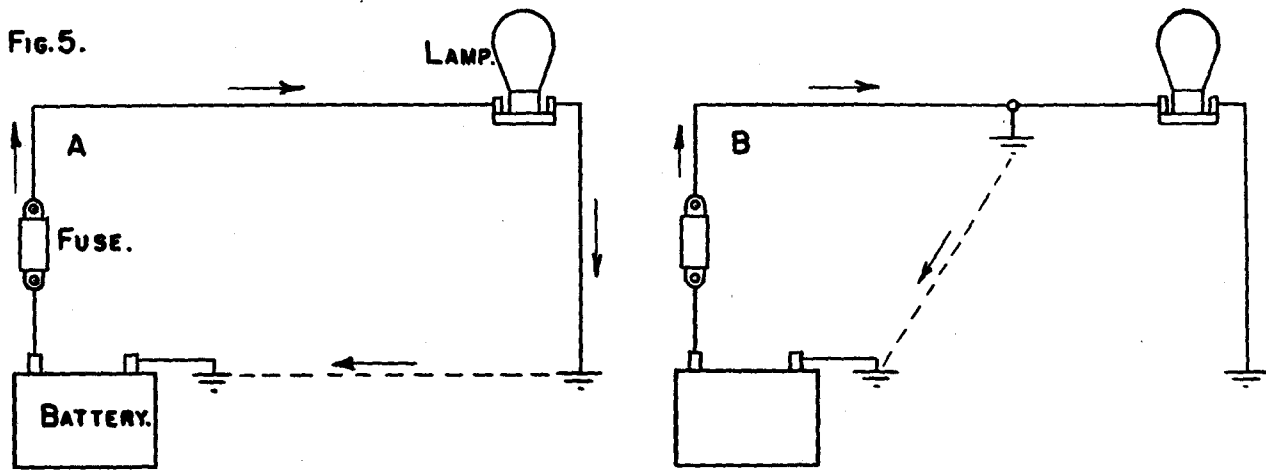

FIG. 6.

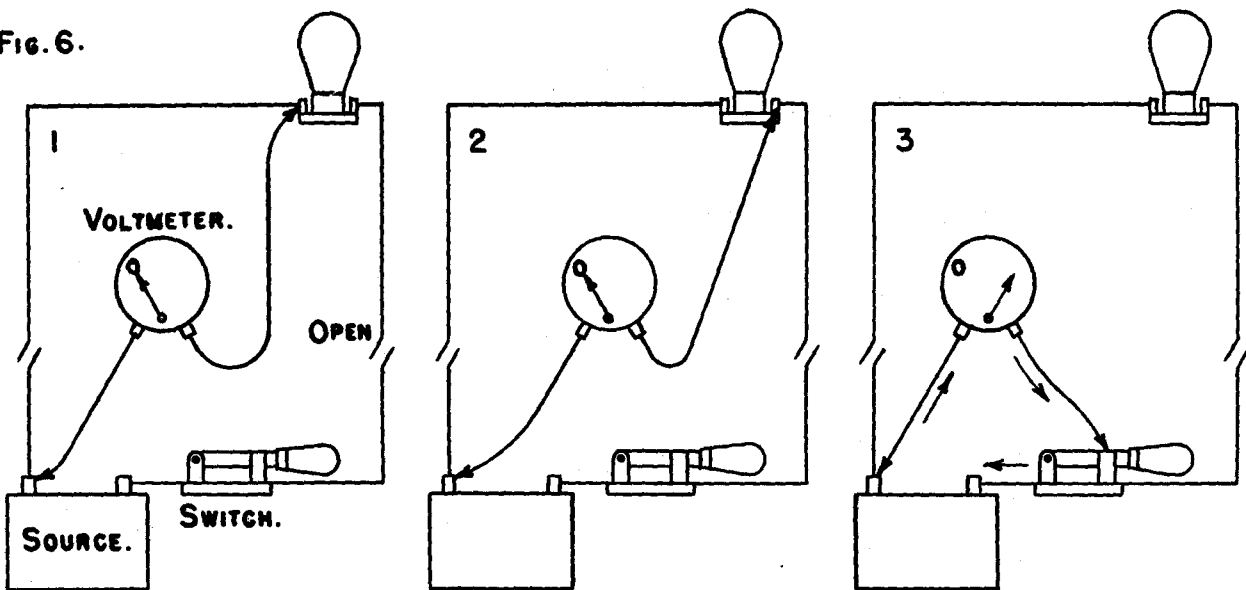
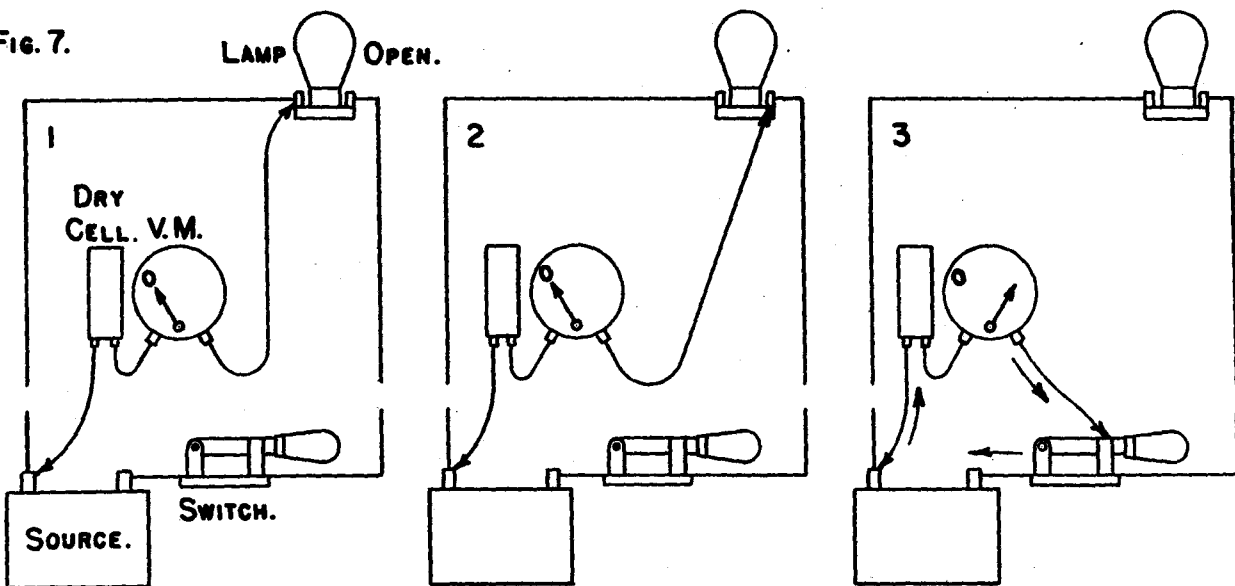

FIG. 7.



a variety of short circuit. An accidental ground permits current to leave the source and return to it without going through the load. This is our fourth general class of circuit troubles.

1. Open circuits. No current in any part of the circuit.
2. High resistances. Abnormally small current in the circuit.
3. Short circuits. Abnormally large current until some protective device acts.
4. Accidental grounds. A variety of short circuit occurring through ground.

While our four classes of circuit troubles will cover nearly all faults that affect the flow of current in circuits, they will not cover all electrical troubles. For example, in the case of motor troubles we would not cover such faults as uneven air gaps, wrong brush positions, reversed phase connections, and many other faults. However, the great majority of electrical troubles are circuit troubles, and the simpler the equipment or device the more likely it is that any existing fault is either an open circuit, a high resistance, a short circuit, or an accidental ground.

CIRCUIT TESTERS

For testing a circuit or part of a circuit that is suspected of being in trouble we require a source of voltage and current, also some means for indicating the flow of current or the lack of it, or a means for showing the presence of a voltage or potential difference.

The source of voltage or of voltage and current for testing may be the same source regularly used for the circuit being tested. That is, for a circuit normally operated from a power line or from the power and light wiring in a building we might use the same line for our testing source. For a circuit normally operated from a battery we might use the same battery. Of course, these sources can be used only if they themselves are not in trouble.

Many kinds of electrical equipment which normally are operated from batteries, radio sets for example, are conveniently tested with voltage and current taken from a power line. Similarly any portable appliances which may be disconnected from the light and power circuits of the building then may be tested with voltage and current from the building line.

A separate source of testing voltage and current, used only for testing, may be a battery. The battery may be connected to the tester only when there is trouble shooting to be done, or it may be mounted within the tester and be a self-contained part of the testing device. Still another source is a small hand-operated magneto, a small alternating-current generator. Magnetos are commonly used in telephone work, also for tests on long lines or long circuits of any kind.

When it comes to indicators for testing voltage and current we have a wide choice. We may use a bell, a buzzer, an incandescent lamp, a neon lamp,

a voltmeter, a milliammeter, or a telephone receiver of the type we call a headphone.

With the great variety of sources and indicators for voltage and current it is possible to make up a great many different kinds of test equipment. In a general way the methods of recognizing open circuits, high resistances, short circuits and grounds are the same regardless of the kind of testing equipment used. Before discussing the particular advantages and disadvantages of the several testers we shall talk about the methods of making systematic tests.

LOCATING OPEN CIRCUITS

To locate the position of an open circuit we may proceed as in Fig. 6, where the accidental open point is in the right-hand vertical wire. For a tester we use a voltmeter, and for a source of testing voltage we use the regular source which supplies the circuit in trouble.

First, as in diagram "1," we disconnect a circuit wire from one side of the source, and to this side of the source connect one of the leads from our testing meter. Starting from the point at which the test meter has been connected to the source we now shall follow along the circuit, and every time we come to a terminal or other point at which the conductors are exposed we shall touch that point with the free lead of the testing meter.

The first test point is the left-hand terminal of the lamp socket. With the tester connected to this point, as in diagram "1" of Fig. 6, the meter reads zero. The next test point as we follow along the circuit is the right-hand terminal of the lamp socket. Here also the test meter reads zero, as shown by diagram "2."

Still following along the circuit we come next to the right-hand terminal of the switch. With the test lead connected here, as in diagram "3," the meter reads the full voltage of the source. Current to actuate the meter flows as shown by the broken-line arrows.

The open point in the circuit is somewhere between the last point at which the meter read zero and the first point at which we had a voltage reading. Thus we determine in which section of the circuit there is an open.

Note that had the circuit not been disconnected from one side of the source before commencing to make tests there would have been a complete conductive path through the circuit wiring between the points at which the test leads are connected. In Fig. 6 no current would flow through this path, because of the open farther along the circuit, and the meter still would read zero in diagram "1" and "2" even had one end of the circuit not been disconnected from the source. But had the circuit been of some more complex type, and had it been possible for some current to flow in the sections bridged by the meter, then the meter would show some voltage drop and the indications might be misleading.

In Fig. 7 we have the same kind of a circuit and have the same open point as in Fig. 6, but instead of using the regular circuit source for our testing voltage we have a "self-contained" tester consisting of a dry cell attached to and connected in series with the testing meter. The connections and the meter indications are exactly the same as in Fig. 6—the meter continues to read zero until we pass the open point, then gives a voltage reading.

Fig. 8 shows what would happen if we failed to disconnect one end of the circuit when using a self-contained tester. With the test connections of diagram "1" the meter would indicate voltage, with current flowing as shown by broken-line arrows. With the test connections of diagram "2" the meter still would read voltage. Therefore, we would have no means of locating the position of the open point in the circuit—the meter would give the same indications no matter where connected.

If we fail to disconnect the circuit being tested, the test indications may or may not be reliable. If we disconnect one end of the circuit the indications always are reliable. Therefore, the safe thing to do is always disconnect one end of the circuit if this is at all possible.

Now let's see what will happen if we proceed to test around the circuit in a direction the opposite of that followed in Figs. 6 and 7. This might mean simply reversing the order of tests; commencing with the test connections of diagrams "3," then making the connections of diagrams "2," and ending with those of diagram "1." With this order of testing the testing meter would indicate voltage with all connections before reaching the open point, and would read zero with all connections beyond the open.

One order of tests would give indications just as reliable as those with the other order, but since the indications are reversed you would have to keep constantly in mind the order in which you are proceeding. The more things of this kind you have to remember the more difficult will be your work, so it is wise to adopt one order or the other and stick to it. Generally it is better, as shown in Figs. 6 and 7, to disconnect one end of the circuit, connect one side of your tester at this end, then proceed from there around the circuit. Then remember that you get a reading after the open point has been passed.

In Fig. 9 we have two opens in the same circuit. One of the open points is a blown fuse, the other is a break in the wire at the right-hand side of the circuit. The successive test connections and the indications are shown by the test meter positions numbered from "1" to "5." With test "2" we have passed an open point in the circuit, yet still have a zero reading of the meter. The zero reading results from the second open point farther along in the circuit. Tests "3" and "4" likewise will give zero readings, but test "5" will show voltage because we now have passed the last open point in the circuit.

You might conclude that the only open point is the one disclosed by test "5." This would be the same kind of error made by men who just "hunt" for trouble without making systematic tests. The thing to do in every case is to repair whatever trouble you first locate, then repeat the tests right through from the beginning. In the present case the second series of tests would locate the blown fuse, because with the connections for test "2" you would have a voltage reading and would know that an open point existed between tests "1" and "2." Having replaced the fuse you then should start over again with the series of tests. Not until all the tests indicate no opens should you consider the job complete. This rule applies no matter what your method of testing and no matter what kind of equipment you are using.

The methods of testing so far discussed might be called progressive tests, in which we connect one side of the tester to a certain point and then progress from that point around the circuit. With a self-contained circuit tester, having its own battery or other source of voltage and current, it is possible to test each part and section of a circuit individually.

Individual tests for opens are shown by Fig. 10. The leads from the tester are bridged across one portion of the circuit after another until you have gone all the way around or have located and repaired a trouble that permits the circuit to act normally again. In each test the indicator will show voltage if the parts tested are not open, and will show no voltage if the parts are open. Current will flow and voltage will be indicated through any portion of the circuit that is complete. If the portion tested is not complete, or is open, there can be no current flow and no voltage will be indicated. No voltage will be indicated because every voltmeter takes some flow of current in order to move its pointer.

In Fig. 10, tests number 1, 3, 5 and 7 check sections of the wiring, and would disclose an open in whichever section is bridged by the test leads. Test number 2 would show up a blown fuse, test number 4 a burned out lamp, and number 6 would show defective contact in the switch. When making individual tests the circuit being tested must be disconnected from the source, at least at one end. Otherwise, voltage from the source will reach the tester when an open point is bridged, and easily may ruin the testing equipment.

A very long circuit, or one containing many devices which might be open, may be checked in large sections as illustrated in Fig. 11. Here both ends of the circuit are disconnected from the source. One side of the circuit tester is connected to any point about midway of the circuit being checked. Then the other test lead is touched first to one of the disconnected circuit wires and then to the other of these wires. With a connection at "1" in Fig. 11 we would check for opens in any part of the circuit from this point around to the right-hand terminal for one of the lamps in the upper line—the point

FIG. 8.

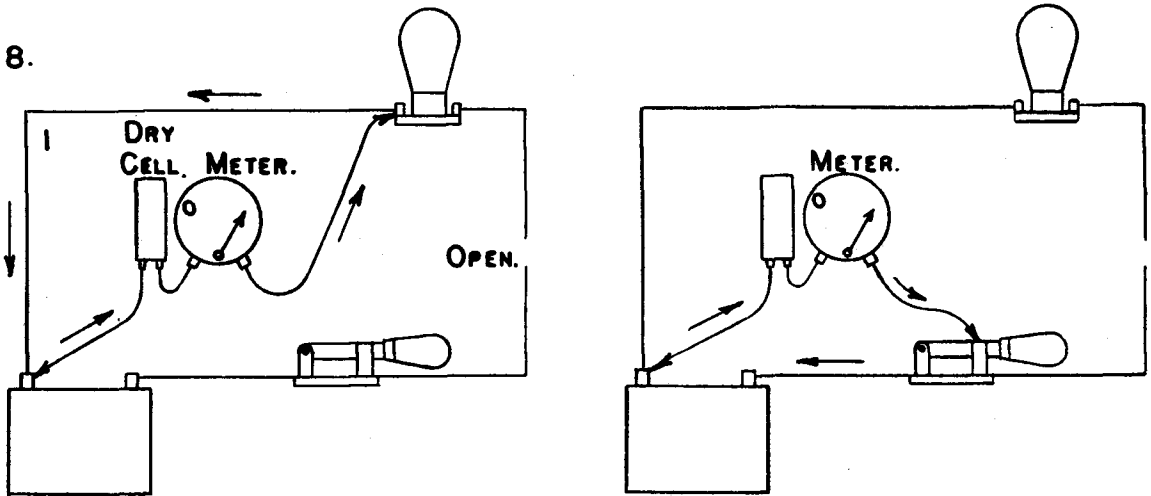

FIG. 9.

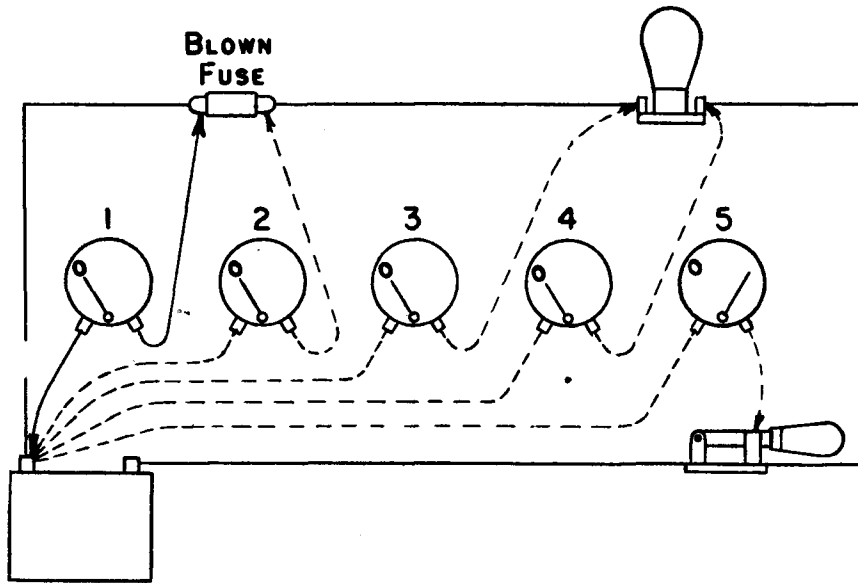
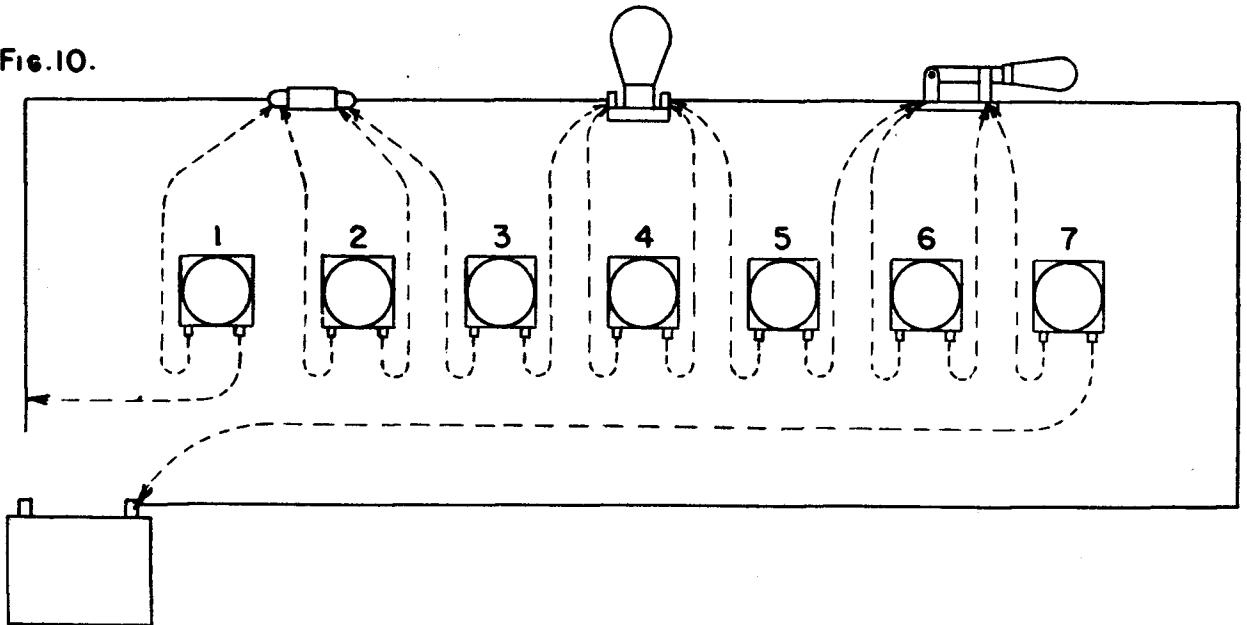

FIG. 10.



where the other side of the tester is attached. With the tester connection at "2" we would check for opens in the remainder of the circuit.

If these preliminary tests should show that an open existed in the section first checked we might further sub-divide that section of the circuit by moving the test lead from between the two lamps to a point between the resistor and signal. Again checking at point "1" would show trouble between this point and the test connection between resistor and signal, while checking at "2" would show trouble existing between the original connection (between the lamps) and the new connection between resistor and signal. This general principle may be used to divide a circuit into any number of sections, a method which may save much time in comparison with either progressive tests all around the circuit or with individual tests.

In all of the tests so far outlined the tester itself has been shown as having a meter for its indicator. A lamp or any other of the indicating means previously mentioned might be used instead of the meter. The source of testing voltage and current might be any of those mentioned earlier. The principles of the tests would not be altered by the kind of test equipment employed.

Fig. 12 shows what probably is the simplest of all tests for open circuits. With this method the circuit being tested remains connected to the source. The tester consists of only an incandescent lamp having a voltage rating the same as the source voltage. For instance, in a 115-volt circuit we would use a 115-volt test lamp. Leads from the test lamp are connected successively across parts of the circuit. When the test lamp bridges a section of circuit or some device that contains an open the lamp will light. Current from the source goes around the open point and through the lamp as shown in diagram "1" of Fig. 12. When the test lamp bridges a part of the circuit that is complete the current will flow through the relatively low resistance of the circuit conductors rather than through the much higher resistance of the test lamp, and the lamp will not light.

There are two objections to this method of testing. One objection is that the source must be in condition to deliver normal voltage and current, but the chief objection is that should the circuit contain more than one open point the test indicates nothing. The reason is shown by diagram "2" of Fig. 12. Here the test lamp is bridging an open point, but because of the second open in the circuit no current can flow and the lamp remains out, just as though there were no open point at all. This method of testing is frequently used for locating blown fuses and tripped circuit breakers.

TESTS FOR HIGH RESISTANCE

All tests for locating points of abnormally high resistance, but points which are not open completely open-circuited, are carried out just as are tests for open circuits. But, since we wish to note the reduced current brought about by the high re-

sistance, it is not enough to use an indicator that merely shows the presence or absence of current. Rather we need an indicator that shows the full current through the low resistance of a circuit in good condition, and which shows the greatly reduced current due to abnormally high resistance.

A tester which is effective for checking high resistances consists of a small incandescent lamp and a battery that will light the lamp to normal brilliancy. When extra circuit resistance is in the tested circuit the lamp will become dim. An ohmmeter which indicates circuit resistance directly in ohms is an excellent testing instrument for locating points in high resistance. Still another suitable arrangement consists of a milliammeter, a battery, and a resistor which limits the current to the full range of the meter. High resistance in the circuit checked will reduce the current through the milliammeter.

When using the method of Fig. 12, a point of fairly high resistance will cause the test lamp to light more dimly than usual when the lamp bridges such a point. This is because some current flows through the high resistance of the circuit and some flows through the high resistance of the lamp. Such a test for high resistance is not so reliable as those made with other types of indicators, it is too difficult to form judgments according to slight changes in lamp brilliancy.

SHORT CIRCUITS

Before commencing to talk about the methods used in locating short circuits and accidental grounds it will be advisable to examine a few general principles applying to these classes of trouble. In diagram "1" of Fig. 13 we have a circuit containing three pieces of equipment marked A, B and C. These units are shown as consisting simply of resistances, but they might represent any kind of equipment since whatever uses electric power has more resistance than the line wires. It is the combined resistance of units A, B and C that opposes flow of current from the source through the circuit, and that limits the current to a value that does not blow one or both of the fuses through which current enters and leaves the circuit.

Diagram "2" of Fig. 13 shows wires disconnected from two of the circuit units. Note that opening this circuit at any point will prevent flow of current from the source into and through the circuit. No current will flow in any part of a series circuit that is opened at any point.

In diagram "3" of Fig. 13 we have represented by a broken line a short circuit that has occurred between one terminal of unit B and one terminal of Unit C. The resistance of unit B has been "shorted out," so current from the source goes through unit A, the short circuit, unit C, and back to the source. The lessened resistance in the circuit, due to B being shorted out, allows excessive current to flow. This excessive current blows one of the fuses.

So long as the short circuit remains it will do no good to replace the blown fuse with a good one, for

Fig. 11.

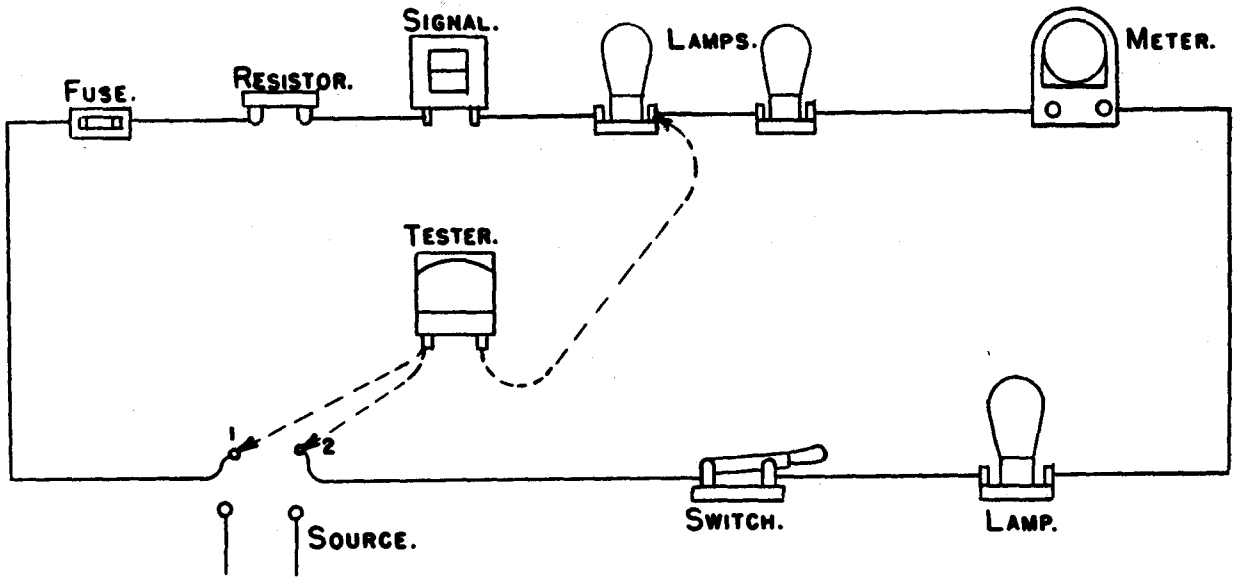
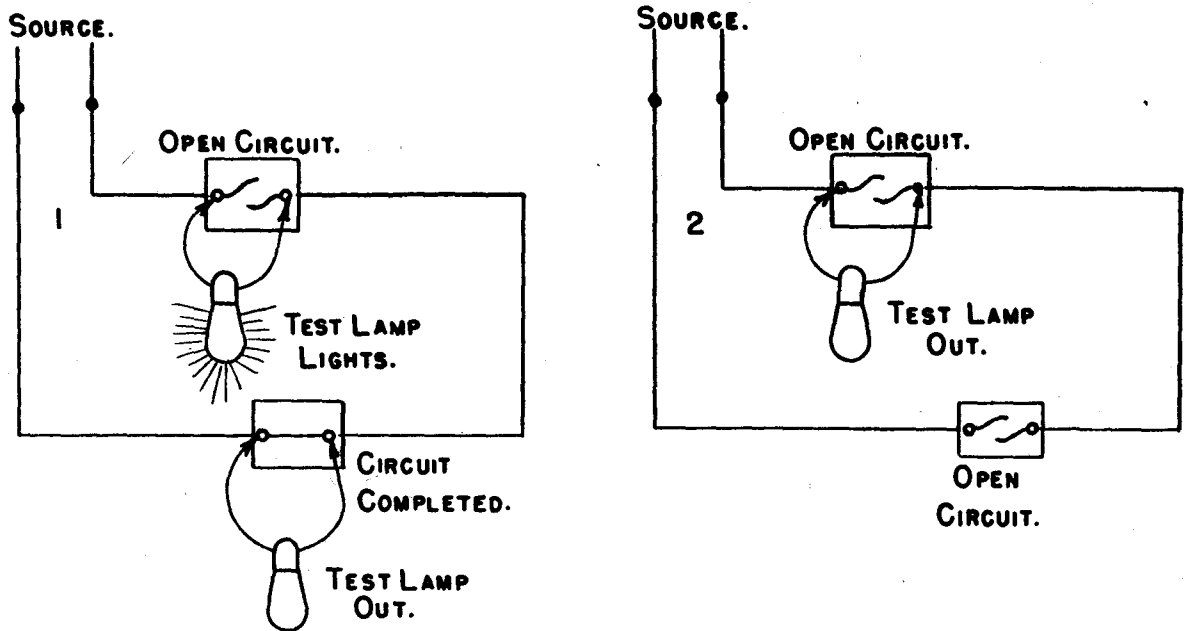

Fig. 12.



the new fuse will be blown by excessive current allowed by the short circuit. Instead of replacing the fuse we connect a test lamp in the place of the fuse, as shown by diagram "4" of Fig. 13. This test lamp must be of a voltage rating the same as the supply voltage.

Now current flows as shown by the small arrows in diagram "4," passing through the test lamp, unit A, the short circuit, unit C, and back to the source. The resistance of the lamp limits the current that may flow. This reduced current is enough to light the lamp but is not enough to blow the remaining fuse. Now we are ready to proceed with our tests.

LOCATING THE SHORT CIRCUIT

The usual method of locating the position of a short circuit is illustrated by Fig. 14. With the test lamp connected in place of the blown fuse, or connected in any manner between the source and the circuit being tested, the lamp will light. Working away from the point at which the lamp is connected we open each accessible point in the circuit. So long as we have not passed the short circuit, each point opened or disconnected will cause the test lamp to go out, as indicated in diagram "1." As each point is disconnected the lamp is observed, if the lamp goes out the connection is replaced to close the circuit at that point and the following point is temporarily opened.

As soon as we pass the short-circuited point, as in diagram "2" of Fig. 14, opening any following points in the circuit will leave the test lamp lighted. This is because current from the source continues to flow through the test lamp and through the short circuit.

The short circuit exists between the last disconnected point at which the test lamp goes out and the first disconnected point at which the lamp remains lighted—this as we proceed along the circuit from the position where the test lamp is connected.

A method of locating a short circuit by using a self-contained tester is illustrated in Fig. 15. A self-contained tester is any type that has its own source of voltage and current, together with the indicating means, in one unit. The circuit being tested must be disconnected from the source, but need be disconnected on only one side if it is inconvenient to disconnect both sides. Then the tester leads are attached to the two ends of the circuit being tested.

With the tester in place we commence disconnecting any accessible points in the circuit, working around in either direction, or starting from either end of the circuit. Each time we open the circuit the tester will indicate zero current so long as the shorted point has not been passed. This is shown by diagram "1" of Fig. 15. As soon as the shorted point has been passed, opening the circuit at any following point will allow the tester to continue showing current. This is shown by diagram "2."

The short circuit exists between the last disconnected point at which the tester reading drops to

zero and the first disconnected point at which the tester continues to show current. Compare this rule with the one for checking with a test lamp (Fig. 14). Except that in one case we have a test lamp and in the other have a self-contained tester, the rules and the indications are the same.

As shown by Fig. 16, a self-contained tester may be connected into a circuit at any point around the circuit provided the circuit is first disconnected from the regular source and the source terminals of the circuit are connected together. Comparing Figs. 15 and 16 will show that they amount to the same kind of connection for the tester, in both cases the circuit is complete all the way around, and is completed through the self-contained tester.

LOCATING ACCIDENTAL GROUNDS

An accidental ground is a type of short circuit in which the short part for current is between a conductor which normally should be insulated and the ground metal which forms part of the circuit. Since a ground is merely one kind of short, the test for locating grounds are essentially the same as those for locating shorts.

Fig. 14 shows the use of a test lamp for locating shorts in an insulated return circuit. Fig. 17 shows the same method of test applied to a ground return circuit. Fig. 15 shows a self-contained tester used for locating short circuits. Fig. 18 shows the same tester used for locating an accidental ground in a ground return circuit. It is apparent that the testers will give the same indications for accidental grounds as they give for shorts between normally insulated conductors. The section of the circuit that is completed through ground or through metallic frameworks is the equivalent of a length of wire conductor.

The general type of ground return circuit shown in Figs. 17 and 18, also by Fig. 5, is the type commonly used for automobile wiring, some radio wiring, for some instrument and meter wiring, and in any cases where the metallic ground takes the place of an insulated copper wire and makes it possible to use less of the insulated wire in completing the circuit.

In the power and light circuits for buildings and distribution systems we have grounded conductors which are grounded for safety reasons, not for reducing the amount of insulated wire required. In these grounded systems of wiring the metallic grounds carry no current except when faults develop that allow contact of the ungrounded conductors with those that are grounded or with the metallic grounds.

The principle of grounding for safety reasons is illustrated by Fig. 19. Here we have a complete two-wire circuit from the source through to the lamp, which represents any load or loads on the circuit. One of the conductors, called the insulated conductor, contains the fuse or other protective device for the circuit, also any switches used for opening the circuit. The other conductor is connected

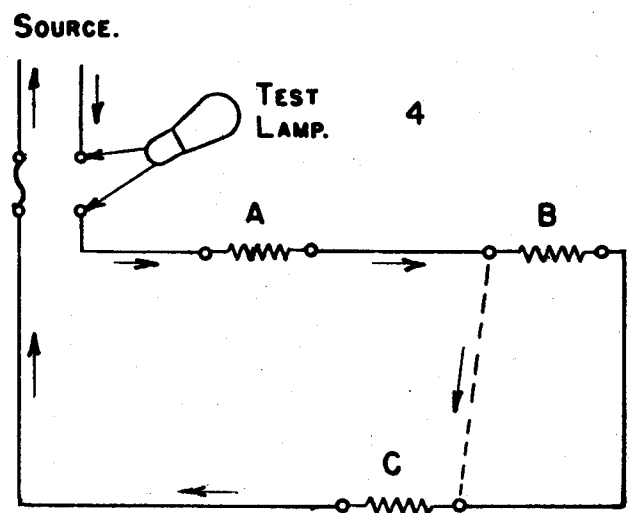
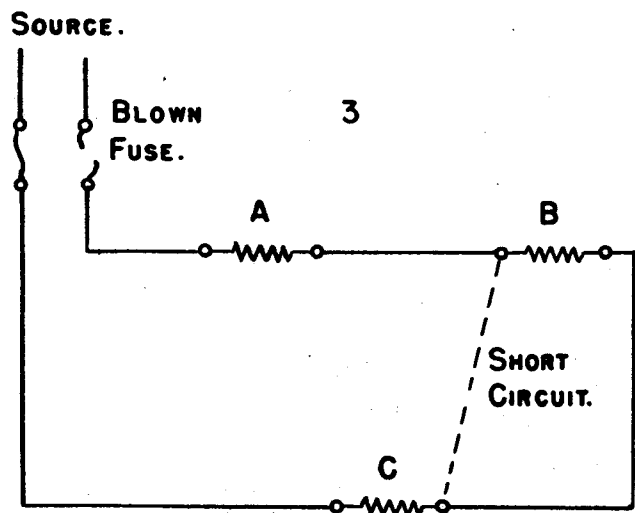
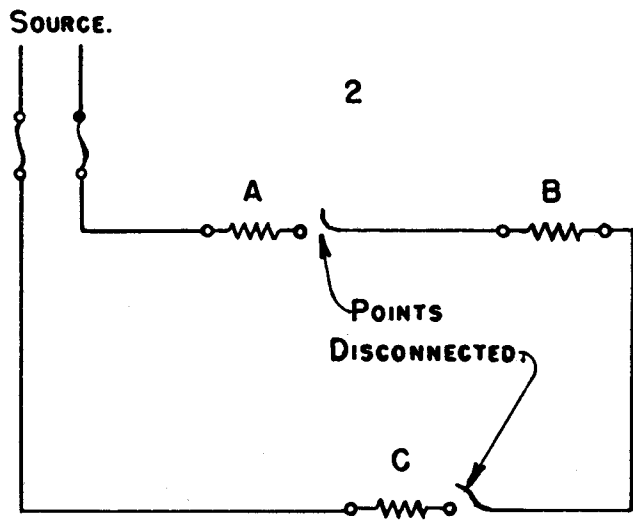
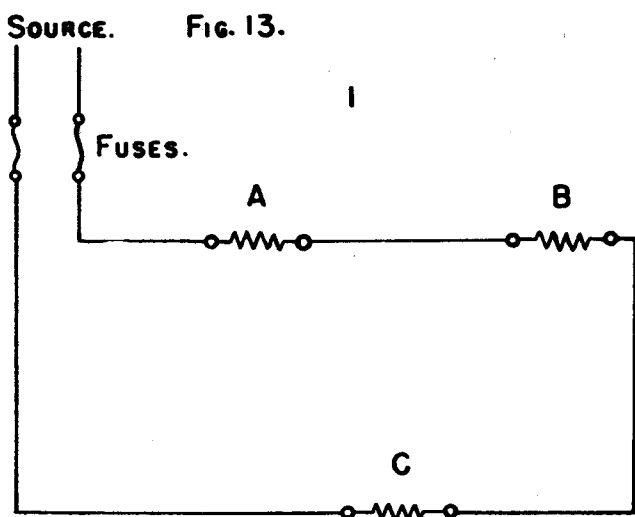

FIG. 14.

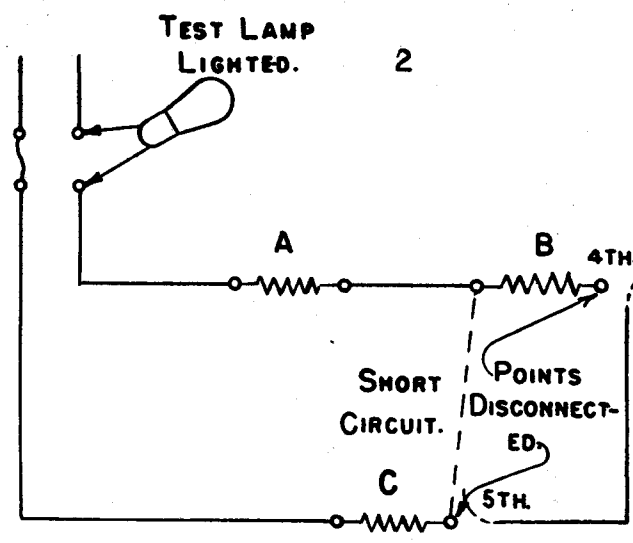
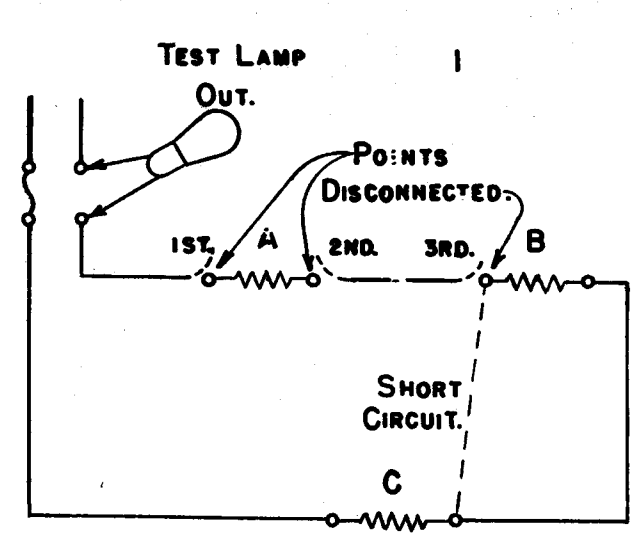

FIG. 15.

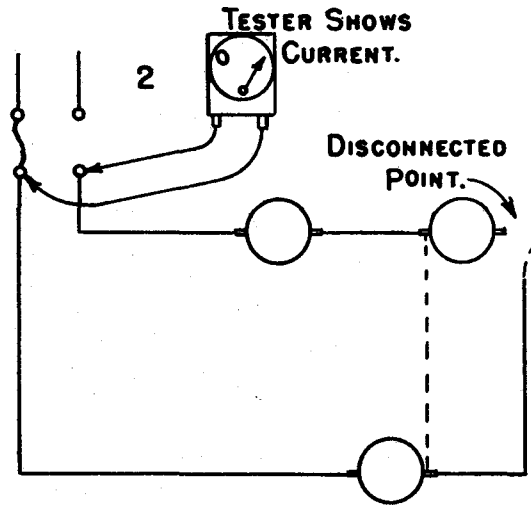
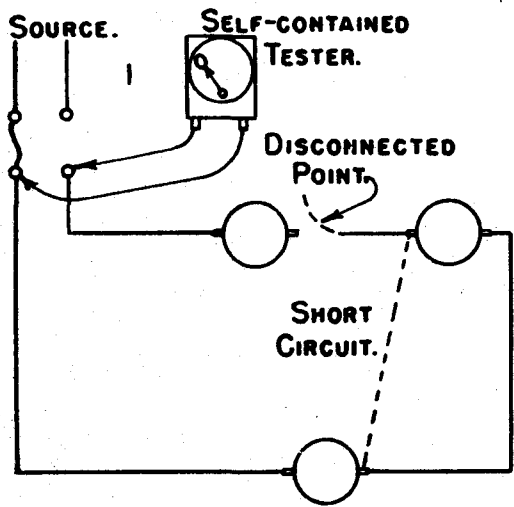

FIG. 16.

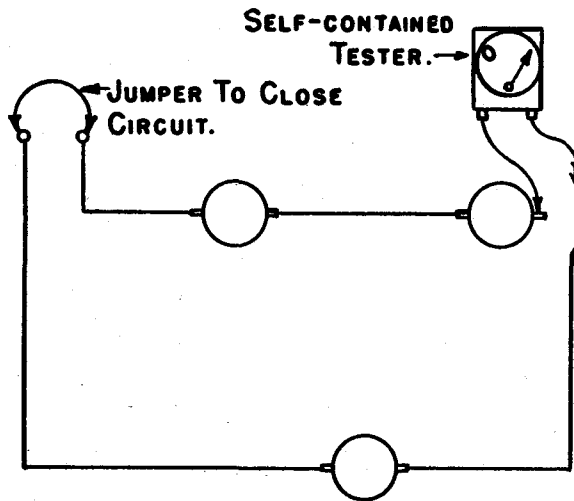

FIG. 17.

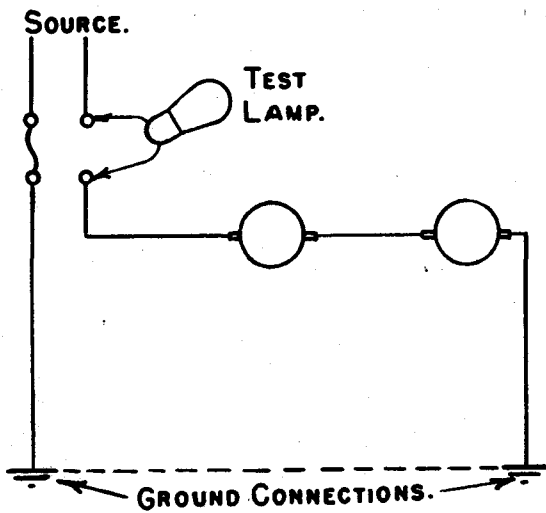
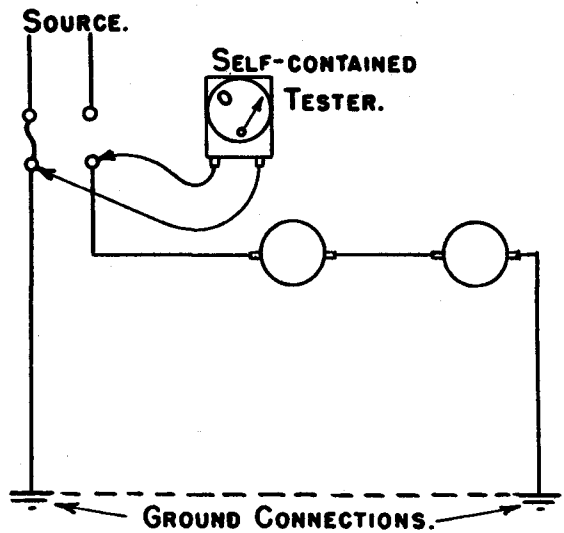

FIG. 18.



to a ground, usually to the cold water piping in the building but sometimes to artificial grounds. The runs of wire in the building are protected by and supported by metallic conduit, boxes and fittings or by other types of metallic raceways. All of these metallic enclosures for the wiring, also the frames and supports of all stationary connected equipment and appliances are grounded through the equipment ground. Since the system ground and the equipment ground connect to the same final ground that enters the surrounding earth, all of the metallic enclosures and frameworks and all of the grounded conductors are connected together into one conductive path.

In wiring installations such as represented in Fig. 19 it is apparent that even the insulated conductor is connected to ground through the lamp filament or through the resistance of any other loads. If we disconnect this wiring from the source, then test from ground to the various conductors we shall find that all of them are grounded. However, the insulated conductors are grounded only through the relatively high resistance of the loads. An accidental ground occurs when an exposed part of the insulated conductors comes in contact with either a grounded conductor or with the metallic enclosures or frameworks. With such an accidental ground there is a path of low resistance from the insulated to the grounded sides. Excessive current through this low-resistance path will blow a fuse or trip a circuit breaker. Note that what we have called an accidental ground between the insulated and grounded conductors really is a short circuit between these two kinds of conductors. It acts like a ground because one of the conductors is grounded.

TESTS IN BUILDING WIRING

The first test for grounds or shorts in building wiring is shown by Fig. 20, with the test lamp or other indicator connected across the clips for the blown fuse or the opened circuit breaker. If there is a short between insulated and grounded conductor, the short circuit, the grounded conductor, and back to the source. If there is an accidental ground, current from the source will flow through the test lamp, the insulated conductor, the accidental ground, the metallic raceway, the equipment ground, the system ground, and back to the source. Lighting of the test lamp will indicate that either a short or a ground exists, but will not tell which kind of trouble is present.

With the test lamp still in the same place the next step is to open one or both of the ground connections as shown by Fig. 21. This may be done at the service equipment for the building. If the test lamp still lights, the trouble is a short circuit between wires, because current no longer can flow through the ground connections. If the test lamp now goes out there probably is an accidental ground.

To check for the presence of an accidental ground on the insulated conductors the test lamp now is connected in either of the ground leads, as shown by Fig. 22. After thus connecting the test lamp, the fuse is replaced or the circuit breaker closed. Replacing the fuse or closing the breaker before inserting the test lamp, with its high resistance, will simply blow the new fuse or re-open the breaker. If the test lamp now lights there certainly is an accidental ground.

The three tests of Figs. 20 to 22 should be performed in this numbered order. If the test of Fig. 20 shows the circuit to be clear there is no use in making the others. Even though the test of Fig. 21 shows a short circuit, the test for ground in Fig. 22 still should be made, because there may be both kinds of trouble.

The tests shown for building wiring may be made with a test lamp or other regular loads may be left in place. The test lamp takes so much current to light it that it will not light or will glow but dimly on any current that goes also through the regular loads, but will light brightly on current through a low-resistance short or ground. A bell or buzzer could be used provided the bell or buzzer were designed for the supply voltage—but this seldom would be the case. An ohmmeter should not be used because it will be subject to the supply line voltage. A voltmeter should not be used because it will indicate full voltage with the current that passes through the regular loads, such as lamps.

LAMPS AS TEST INDICATORS

Having examined many of the more common methods for locating circuit troubles we now are in a position to appreciate the advantages and disadvantages of some types of test indicators. First we shall consider incandescent lamps and neon lamps.

When used with the regular source for testing voltage and current, an incandescent lamp should be a rated voltage as high as, or even higher than the supply voltage. The lamp should be of low candlepower or low wattage, bulbs of 6 to 25 watts being generally satisfactory. With small lamps the testing current is small and is unlikely to do any harm. The test lamp should be of the carbon filament type because such filaments withstand much more abuse than do tungsten filaments. The test lamp socket should be of the weatherproof type, with a molded composition body from which extend two wire leads. Metal brackets are likely to cause shorts and grounds through themselves, while porcelain sockets are easily broken.

The simplest and least expensive self-contained tester is made with one or two dry cells and a small incandescent lamp as shown by Fig. 23. The lamp should be rated at $1\frac{1}{2}$ or 2 volts for a single dry cell and at 3 to 4 volts for two cells. Flash light bulbs may be used, but 3-4 volt automobile tail or dash light bulbs with two dry cells usually are more satisfactory. The dry cells should be of num-

FIG. 19.

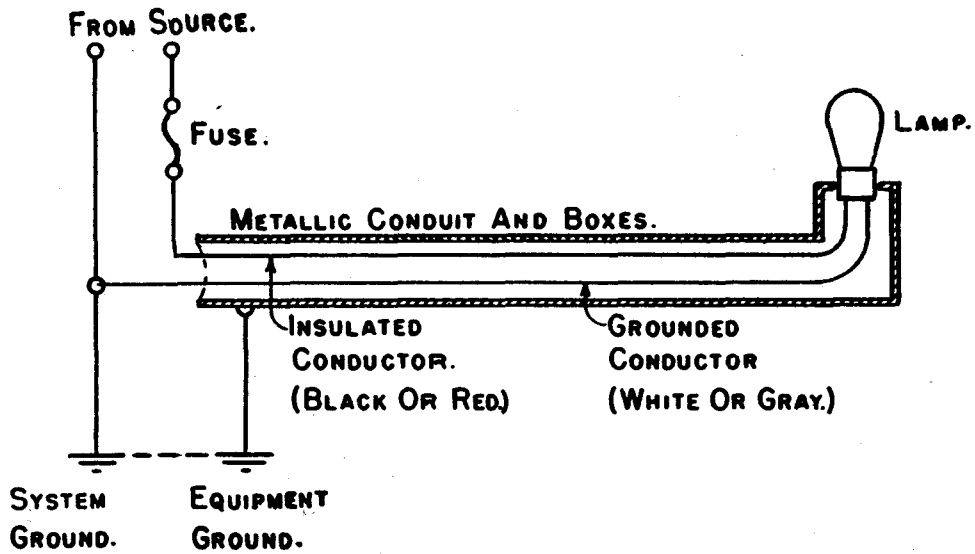

FIG. 20.

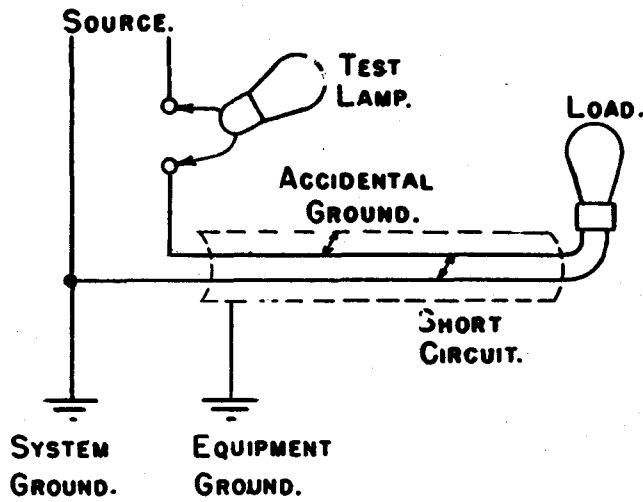

FIG. 21.

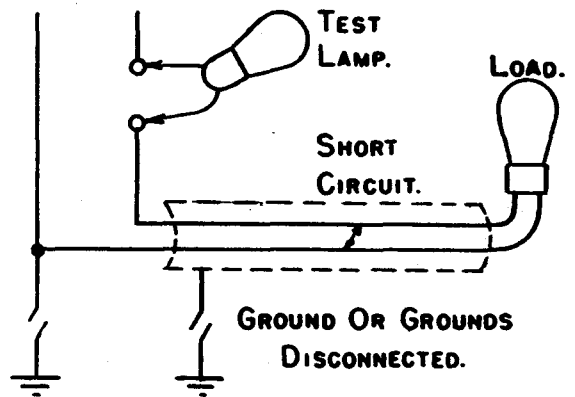
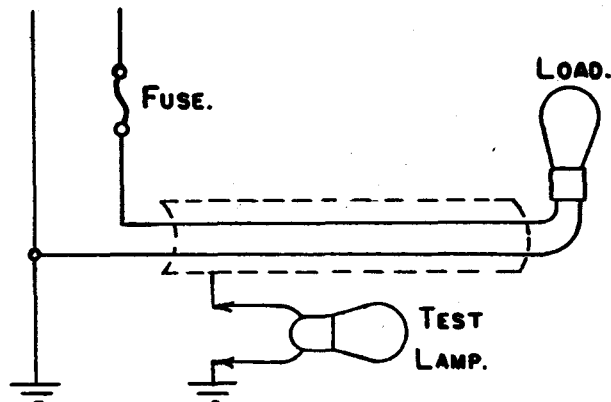

FIG. 22.



ber 6 size, since any smaller sizes discharge quickly and then cause unreliable indications.

Neon lamp bulbs such as used for night lamps and signal lamps come in ratings of one-quarter to three watts for operation on 110-120 volts. These bulbs will light on either direct or alternating current, both plates or electrodes lighting on alternating current and only one of them on direct current. It takes a rather high voltage, such as supply line voltage, to "break down" a neon lamp and cause it to glow, but once the glow is established it will continue with a current of only a few milliamperes or, in the small bulbs, with a current measured in micro-amperes.

When used with an alternating-current source a neon bulb will light and continue to glow with current that passes through the capacitance between adjacent insulated conductors, so will glow on current through an open circuit. With direct-current supply of voltage high enough to operate the lamp, the neon lamp will flash but will not continue to glow with current through such an open circuit. In general, the neon lamp is too sensitive or takes too little current to make it reliable for ordinary circuit testing.

BELLS AND BUZZERS

A vibrating type of doorbell or buzzer may be used in a self-contained tester: made up with two number 6 dry cells, the connections to the bell or buzzer being the same as to the lamp bulb of Fig. 23. Bells and buzzers of usual styles take so much current to operate them that they will not ring or buzz through a circuit containing even moderately high resistance, but they will operate through a low-resistance short or ground. The large currents taken by these indicators will quickly discharge even the large size dry cells. The chief advantage of ordinary bells and buzzers is that they give an audible signal and make it unnecessary to watch the indicator while making test connections.

High-frequency low-current buzzers which operate on four to six volts make satisfactory test indicators for self-contained testers using three or four dry cells or a dry cell battery of equivalent overall voltage. The only real objections to such buzzers are their high cost for good types, and their failure to buzz in the cheaper types.

MAGNETO TEST SET

A magneto test set, shown in principle by Fig. 24, consists of an alternating-current generator or a magneto, operated by a hand crank, and connected in series with a polarized bell and the terminals for the test leads. A polarized bell has a permanent-magnet armature and will ring on alternating current. Most magnetos are designed to ring their bells through a circuit resistance of 20,000 to 40,000 ohms, and, of course, through any smaller resistance.

Among the advantages of the magneto test set are ease of operation a signal that is clearly audible,

and the ability to test through circuits of high resistance. One disadvantage is that circuits containing large self-inductances, such as coil windings, have large opposition to alternating current and may prevent the bell from ringing. Another disadvantage is that the alternating current will act through capacitances, and when a circuit contains either condensers or long closely spaced insulated conductors the bell ringing current will pass through these parts even though there would be an open circuit for direct current.

VOLTMETERS FOR INDICATORS

A voltmeter for use in direct-current circuits consists of a meter movement in which the pointer moves all the way across the scale with a current of from one to 10 milliamperes in most designs. Within the meter case or attached to it, and in series with the movement, is a resistor of high enough value so that application of the full-scale voltage to the meter terminals will limit the current to just enough for full-scale travel of the pointer. Such a meter is shown by Fig. 25.

The voltmeter alone may be used just as a lamp or other indicator is used when the source of testing voltage and current is a line supply, or it may be used with any other source temporarily connected in place of the line of supply. In any case, the full-scale range of the meter must be at least as high as the maximum voltage from the test source.

For a self-contained tester the voltmeter is connected in series with a dry-cell battery as shown in Fig. 25. The terminal voltage of the battery must be no higher than the full-scale range of the meter.

An advantage of the voltmeter is that its own high resistance prevents any but small currents in the circuit tested. Large currents through equipment tested, especially when they are direct currents, may either magnetize soft iron cores that should not be magnetized, or may partially demagnetize some parts that should have definite magnetic polarities. The small current required to move the meter pointer allows using a battery of small capacity with assurance of reasonably long service. A disadvantage of the voltmeter for some tests is that it will indicate nearly full voltage through a rather high external resistance or a high circuit resistance. Thus it is not easy to recognize the presence of abnormally high resistances in the circuit tested.

Voltmeters for testing with alternating-current line power as the source usually are of the rectifier type. A rectifier meter consists of the same type of movement shown by Fig. 25 and of a current-limiting resistor. Between the movement and the terminals of the meter is a rectifier which changes alternating current into pulsating direct current that will operate the meter movement. There are other types of alternating-current voltmeters, but they take so much current for their own operation that we lose most of the advantages of a voltmeter

FIG. 23.

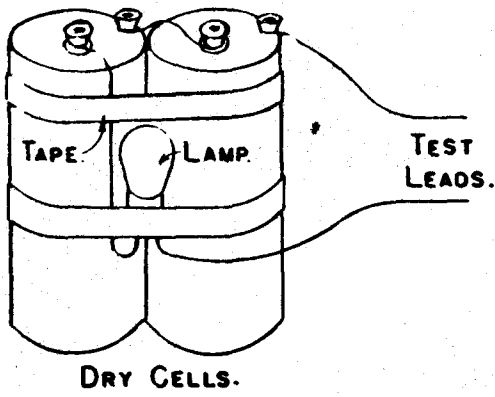

FIG. 24.

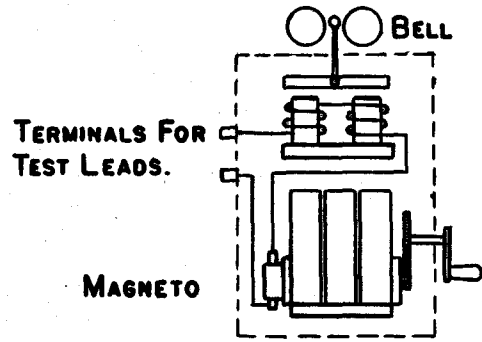

FIG. 25.

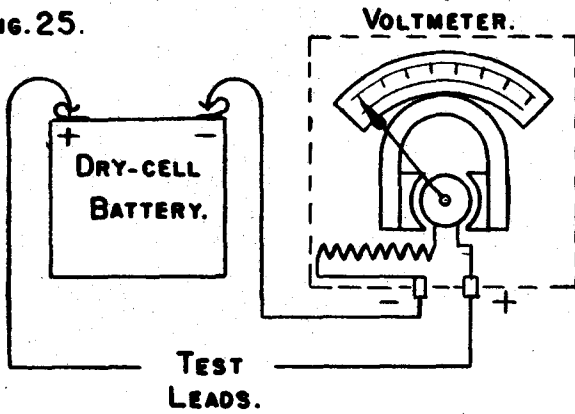

FIG. 26.

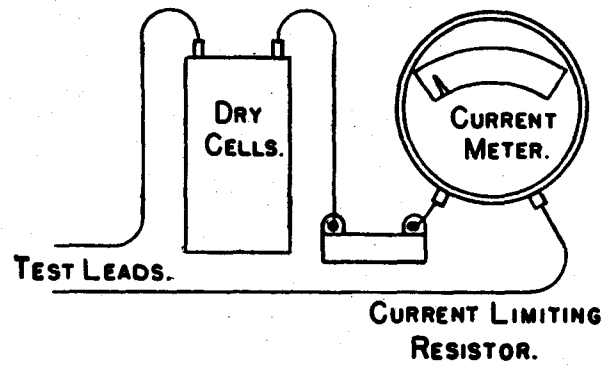
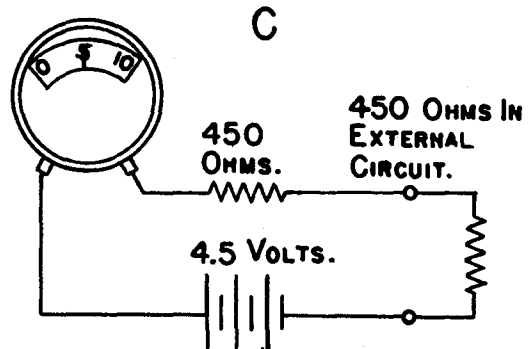
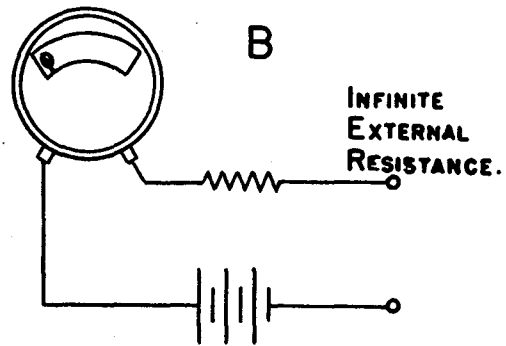
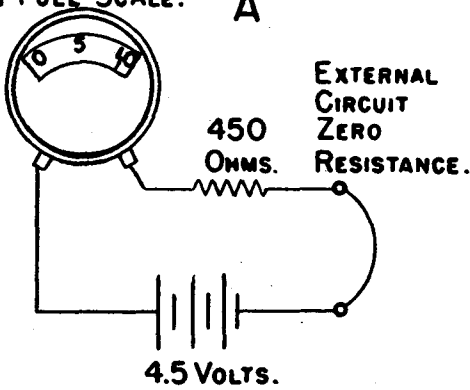

FIG. 27.

10 MILLIAMPERES AT FULL SCALE.



and might almost as well employ a small test lamp.

An alternating-current voltmeter would not be used in a self-contained tester, since they only practicable source of alternating current would be a magneto or small a.-c. generator. With a magneto we might better use a polarized bell.

CURRENT METERS FOR INDICATORS

If an ammeter or milliammeter is used as a test indicator there must be permanently connected in series with the meter, and close to the meter, a resistor which will limit current to the full-scale value of the meter when the highest possible testing voltage is applied. Neglecting the small internal resistance of the meter itself, the number of ohms in the limiting resistor must be equal to the maximum of applied volts divided by the full-scale current of the meter as measured in amperes, not in milliamperes.

Unless it is necessary to measure current in amperes or milliamperes during tests, a current-meter should not be employed. There is too much danger of applying excessive voltage and of burning out the meter. A delicate milliammeter without a protective resistor may be burned out by connecting it to a single flash light cell.

A milliammeter, a current-limiting resistor, and a dry cell battery may be assembled into a self-contained tester as shown by Fig. 26. The number of ohms required for the resistor is found by multiplying the battery volts by 1,000, then dividing the product by the full-scale milliamperes of the meter. Such a resistor will limit the meter current to the full-scale value when testing a short circuit and when the battery is fresh. The tester thus assembled is practically the same as the self-contained voltmeter type of Fig. 25, except that the limiting resistor is a part of the voltmeter and is added to the milliammeter.

A milliammeter of the rectifier type might be used when testing with alternating current as the source. Again it would be absolutely necessary to permanently connect a current-limiting resistor in series with the meter, so again it would be better to use a voltmeter rather than a current meter.

OHMMETERS

Fig. 27 illustrates the basic principle of a commonly used style of ohmmeter, an instrument that indicates on its dial scale the ohms of resistance in a circuit to which it is connected. At "A" in Fig. 27 we have a milliammeter which reads 10 milliamperes at full scale, a 3-cell $4\frac{1}{2}$ -volt dry cell battery, and a 450-ohm resistor, all in series between the terminals to which is connected an external circuit here shown as having zero resistance.

Ohm's law shows that the current is 10 milliamperes through 450 with $4\frac{1}{2}$ volts applied, so, neglecting the small internal resistance of the meter itself, we have a full-scale reading of the meter. At "B" we have disconnected the external circuit from the terminals, so no current can flow and the

meter reads zero. With the terminals open we have between them an external resistance so great that it is called infinite resistance.

At "C" in Fig. 27 the terminals are connected to an external circuit having a resistance of 450 ohms, the same as the resistance of the resistor in the ohmmeter. Now the total resistance in series with the meter and battery is 900 ohms. Ohm's law shows that this resistance allows a current of 5 milliamperes with $4\frac{1}{2}$ volts applied. Thus we have a half-scale reading of the meter.

The dial scale of an ohmmeter is graduated in ohms rather than in current values. Infinite external resistance is indicated by the pointer all the way to the left, zero resistance is indicated by the pointer all the way to the right, and intermediate resistances are indicated by intermediate readings. The graduations are farthest apart at the low-resistance right-hand end of the scale and get closer and closer together as they go toward the high-resistance left-hand end.

In a practical ohmmeter there is allowance for the internal resistance of the meter movement, also adjustments for battery voltage and to compensate for gradual fall of voltage as the battery discharges.

One of the best of all test instruments may be made with parts such as shown in Fig. 27 enclosed in a case with terminals for test leads. Unless we wish to measure exact numbers of ohms it is not necessary to allow for movement resistance nor to provide adjustment for battery voltage or battery discharge. The number of ohms in the fixed resistor inside the ohmmeter case is found by multiplying the battery voltage by 1,000, and dividing this product by the full-scale milliamperes of whatever meter is used. Because of the extra resistance of the movement the pointer will not go to full scale even with the terminals connected together through a short copper wire, but the pointer will go almost to full scale. A half-scale reading always will indicate an external resistance approximately equal to the fixed resistance used in the ohmmeter.

A self-contained tester of this type will indicate an open circuit by its pointer remaining at the left-hand end of the meter scale, will indicate a "dead" short or a low-resistance ground by the pointer going almost all the way to the right, and will indicate resistance by the pointer going to some intermediate position on the scale.

TELEPHONE RECEIVER FOR TEST INDICATOR

Fig. 28 shows the connections for a telephone receiver or radio headphone used as a tester. One or two dry cells are connected in series with the receiver and the test leads, preferably with cords long enough so that the dry cells may be carried in your pocket with the headband and receiver in place on your head, thus leaving both hands free to work with the test leads.

When one lead is connected to one side of a circuit being tested, and the other lead is lightly

FIG. 28.

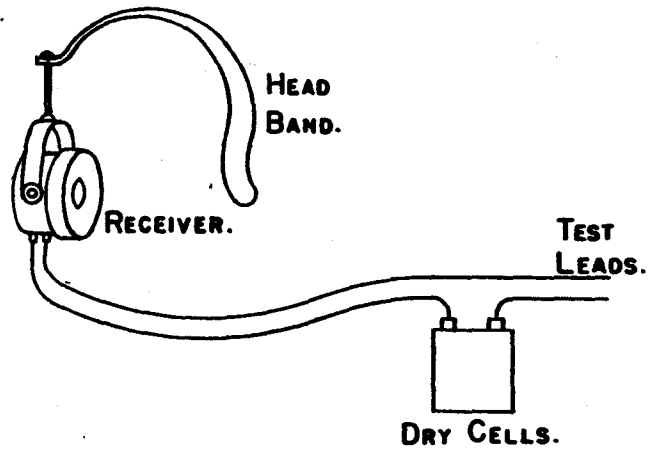

FIG. 29.

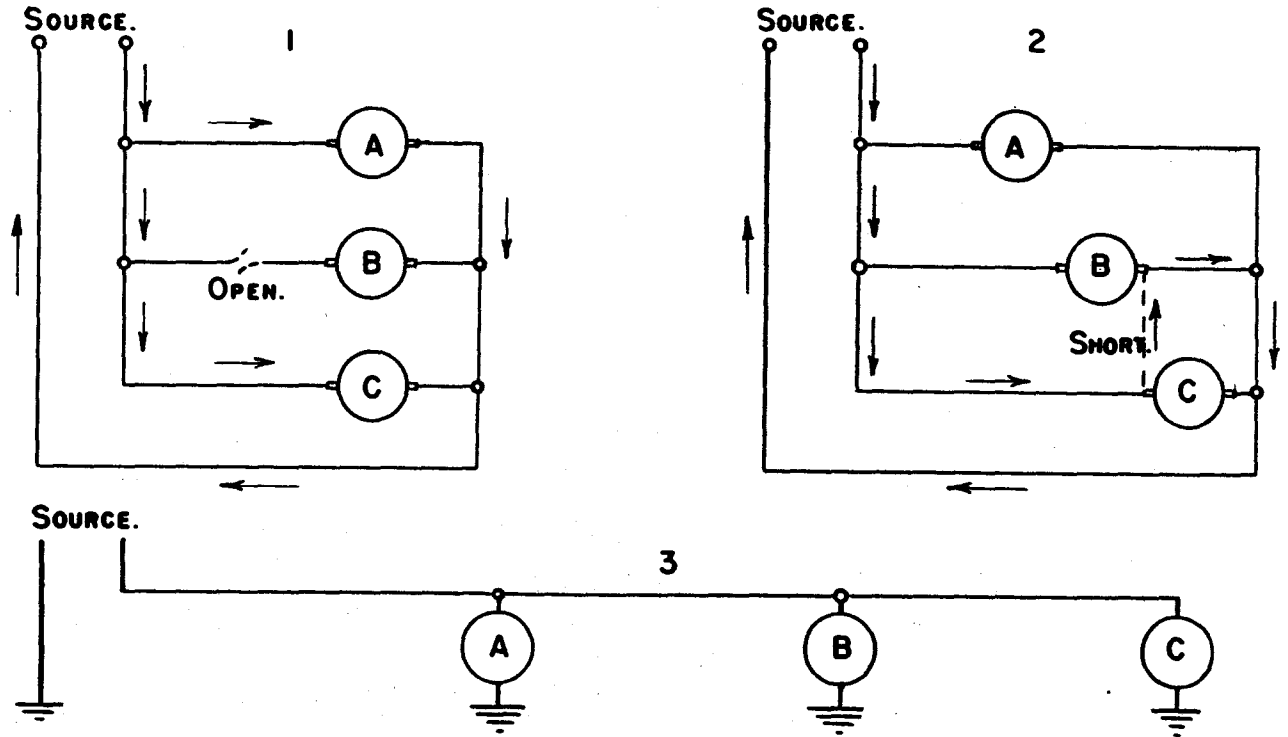
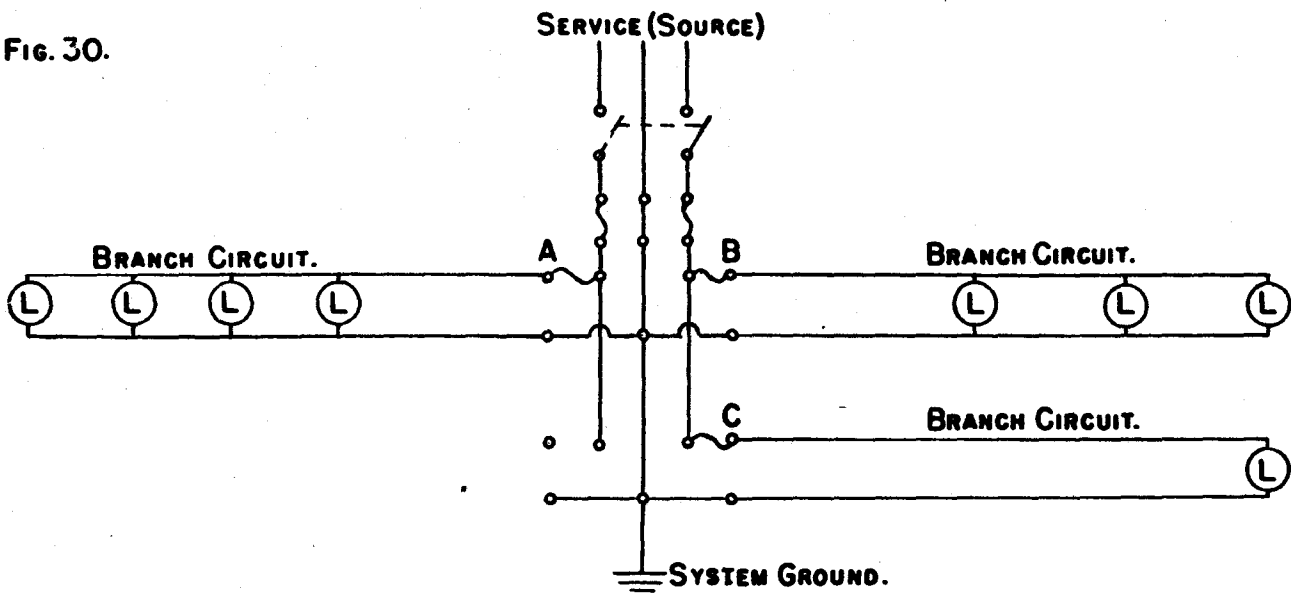

FIG. 30.



touched to and withdrawn from the other side of the circuit, there will be pronounced click in the receiver if the circuit is complete, and there will be no click or only a weak one if the circuit is open. If the circuit being tested contains high resistance the click will be weaker as the resistance increases.

Some circuits have quite a bit of capacitance, either in the form of condensers or capacitors, or else between adjacent insulated conductors in long circuits. When the telephone receiver is used for testing such circuits there will at first be a loud click as the capacitance takes a charge. If one lead then is removed and quickly reconnected the click will be weaker, but if much time intervenes between taps the click will be as loud as before if the capacitance is due to long insulated wires.

After enough experience in using the telephone receiver so that its indications may be quite surely recognized, this makes a decidedly useful tester, but at first the clicks or absence of clicks is likely to be misleading.

TESTS ON PARALLEL CIRCUITS.

Up to this point all our diagrams of circuits tested have shown series circuits. A series circuit is one in which all the current flowing in any one part must flow also through every other part of the circuit. It is a circuit in which all the parts are connected "end-to-end", and in which the two outer ends of the circuit are connected to the source.

A parallel circuit consists of two or more current paths connected across the same source. Fig. 29 shows loads A, B and C connected across a source. The voltage of the source is applied equally to all the loads connected in parallel, and the total current from the source divides between the loads connected in parallel.

In diagram "1" of Fig. 29 there is an open circuit in the branch line for load B, but, as shown by the arrows, current still flows as usual through loads A and C. We might be able to locate the open circuit by measuring the change of resistance across the source, but this would require knowing the original resistance of the circuit when in good condition—a knowledge we seldom would have.

In diagram "2" of Fig. 29 there is a short circuit between terminals on loads B and C. Current from the source follows the path shown by arrows, passing through none of the loads but going entirely through the low-resistance wire conductors. No current to speak of flows through any of the loads. The excessive current through the wire conductors will blow a fuse or trip a circuit breaker, just as will the short-circuit current in any other circuit.

Diagram "3" in Fig. 29 shows a ground return circuit with the three loads in parallel across the source. Opens and shorts in this circuit would act generally as they do in any other circuit, and accidental grounds would act like short circuits—just as they do in a series connection.

To locate opens, shorts and accidental grounds in parallel circuits, or with loads connected in parallel we nearly always must disconnect the parallel branches from one another and test each branch as a series circuit, which it is when disconnected from other branches. Then the tests for various kinds of faults are exactly the same as those we already have studied.

Lighting and appliance branch circuits in buildings ordinarily are wired according to the principle shown in Fig. 30, where the symbols marked L represent lamps or appliances. In each branch the lamps or appliances are in parallel between the two wire lines, but the relatively high resistance of lamps between the two sides of the branch circuit allows testing the branch like a series circuit when it is disconnected from other branches. Each branch may be disconnected from the service equipment by removing the fuse or opening the circuit breaker that protects the branch. The left-hand branch of Fig. 30 would be disconnected by removing fuse A, then testing this branch according to the methods of Figs. 20 to 22. The upper right-hand branch would be disconnected by fuse B, and the lower right-hand branch by fuse C.

Parallel circuits having exposed conductors running between separate pieces of equipment may be broken up into series sections after inspecting the connections. When the conductors are concealed, as with the internal wiring of appliances and other electrical apparatus, it usually is necessary to have a wiring diagram of the equipment before it is possible to carry out positive tests for circuit troubles.

DETERMINING THE PROBABLE TROUBLE

Blown fuses, tripped circuit breakers, and evidences that equipment and insulation have been overheated indicate that the circuit troubles are shorts or grounds. When such symptoms are present you should commence your work with tests for shorts circuits and accidental grounds rather than with tests for open circuits.

If lamps, appliances and other equipment fail to operate, and if fuses or circuit breakers are not open, it is probable that there is an open circuit and it is for such trouble that you first should make tests. When any equipment refuses to start or to operate, the correct procedure is to check for voltage at the equipment terminals with switches turned on. You can make this check with a test lamp having a voltage rating the same as that of the supply line. If the lamp lights brightly there is voltage at the equipment and there are no open circuits in lines coming to the equipment. If the lamp lights dimly there probably is high resistance somewhere in the lines, and if the lamp fails to light at all there is an open circuit.

Before making instrument tests for open circuits look for any switches which may have been opened in lines between the supply source and the equipment, and look for blown fuses or open circuit breakers in the lines. If switches, fuses and circuit

breakers are closed, check for voltage all the way back to the source or to the point at which the circuits connect to a supply line.

TESTING INTERNAL CONNECTIONS

All of the diagrams that have illustrated circuits and methods of testing them have shown the loads or circuit units as though they were well separated from one another and had exposed wires running between them. Exactly the same methods are used for testing internal connections and internal circuits in any kind of electrical equipment. Whether you are checking a circuit between lamps in separate rooms of a building, or one between adjacent tubes in a radio set makes no change in the general principles of testing for circuit troubles.

When testing the circuit and connections inside any one piece of electrical equipment much time will be saved if you have a wiring diagram or a schematic circuit diagram for the equipment, especially if the construction is at all complicated. It would be relatively easy to check the internal connections of something so simple as a vacuum cleaner containing only a motor, control switches and their connections. It would be more difficult to test an electric range with its many additional control switches and thermostats.

CHOICE OF TESTING METHODS

With the various kinds of testing equipment we may employ either alternating or direct current supplies; taking alternating current from a supply line or a magneto, and direct current from batteries in most cases but sometimes from a d-c line. When you have a choice it is a good idea to use alternating current for testing circuits and equipment that normally operate with such current, and to use direct current for those that normally operate with direct current. However, unless the circuit being tested contains coils that provide considerable inductance, or capacitors that provide considerable capacitance, direct-current testing equipment is just as good as alternating current in every case.

The voltage used for testing should preferably be as high as the normal operating voltage of the circuit tested, at least when you are using lamps, bells or buzzers for the test indicator. It is entirely possible for a short circuit or accidental ground to allow large leakage currents on 110 volts and yet

not allow enough leakage to light a test lamp or ring a bell on voltage from one or two dry cells. When using more sensitive indicators, such as voltmeters and ohmmeters, any voltage that operates the test instrument is sufficiently high for all usual tests.

When you use a high testing voltage, such as line voltage, always limit the testing current to the smallest possible value that will operate the indicator being used. A 6-watt lamp, taking but a small fraction of an ampere of current on a lighting and power circuit, gives indications that are just as positive and just as reliable as those of any larger lamp that takes much more current. The advantage of using a high testing voltage is in the fact that the high voltage will force current through faults in the circuit, but the least possible current is just as effective as a big current so far as test indications are concerned.

Test leads should be of very flexible wire with conductors formed from braided strands covered with flexible insulation such as a thin layer of rubber and two layers of braided fabric. It is convenient to have a spring clip at the end of one test lead. This clip may be firmly attached at one point in the circuit tested. At the end of the other lead should be a pointed test prod enclosed almost to its tip with rubber, fibre or composition insulating tubing. It is advisable also to have a sleeve of soft rubber over the spring clip. Unless the end of the test leads are protected with insulation clear to the tips with which connections are made, the exposed conductors of the leads will cause plenty of shorts and accidental grounds while you are making tests.

A test lamp used alone, with line power for the testing voltage and current, should have insulated spring clips on both leads so that it may be connected securely between terminals or fuse clips while you check for circuit troubles. When connecting such a lamp to the circuit do not take hold of both clips at the same time and attach them. By doing this you are likely to get a severe shock. Use only one hand at a time, clip one lead in place, let go of it, then clip the other lead in place. The same general method of making test connections should be followed with any test equipment that employs high voltage or line voltage.

ELECTRICAL DIAGRAMS—WHAT THEY MEAN AND HOW TO READ AND USE THEM

THE EASY WAY TO LEARN

The language of electricity is written in electrical diagrams, and the best and quickest way to learn how to read and draw electrical diagrams is to start right in reading the kind of diagrams used by men in the electrical industry.

Instead of first trying to memorize all the little separate rules and methods that engineers use in making diagrams, then trying to fit these things together later on, it is far better to commence studying complete practical diagrams right in the beginning. Nothing could be better adapted to such study than the diagrams in this book, for they not only represent actual electrical practice, but they have been proved through constant use by hundreds of electrical men working and learning in the Coyne School shops.

SYMBOLS AND PICTURES

Electrical diagrams show wires and other connections between separate electrical devices, such as a lamp and a switch, or may show the connections inside some electrical device, such as those inside a motor. The wires are easily shown by simple lines on the diagram, but it is not always so easy to show the connected devices, such as lamps, switches and motors. These devices might be shown with pictures, but there is a better and simpler way.

The reading of all electrical diagrams is made relatively easy by using **symbols** instead of pictures to represent electrical parts. A symbol is a sort of simplified picture, a kind of sign writing. The difference between symbols and pictures is shown on the two pages at the beginning of the Wiring Section, where many common electrical devices are shown both ways.

A picture can show the external appearance of only one particular make or model of an electrical part, and in nearly every case fails to show how the part behaves electrically. Consider the pictures of switches shown on one of the pages of symbols. Except for the knife switches, where the working parts are exposed, any of these switch pictures might represent almost any type of switch—open circuit, closed circuit, double circuit or double throw. But the symbols for the switches indicate quite clearly how the switches work electrically, how they are supposed to open and close electrical circuits. The same differences between symbols and pictures show up with adjustable resistors and with other devices having moving parts.

SYMBOLS

For quite a few electrical parts we have a choice of two or more symbols which mean the same thing. For instance, wires that cross without being

connected may be shown in any of three ways. Some engineers and draftsmen use one method, while others use a different one—it's just a matter of personal choice.

Other examples of different symbols for the same thing occur with cells and with batteries. The shorter lines may be of the same thickness as the longer lines, or the shorter ones may be much heavier. Transformers may be shown with zig-zag lines or with loops, resistors may be drawn to look like a dovetail joint or to look like saw teeth. The meaning of a symbol is not altered by the style used, any more than the meaning of words is altered by writing them sometimes slanting, sometimes vertical, and sometimes backhand.

The man who makes the diagram may specify, usually by a note on the diagram, that certain styles of symbols have special meanings on that one diagram. For example, it might be noted that resistors shown like a dovetail indicate those constructed with cast iron "grids," and that those shown by a saw-tooth line indicate those that are wire-wound. But these are special cases and they do not alter the general meanings of the symbols.

Compared with pictures, symbols are easier to draw, are easier to recognize even though roughly or crudely drawn, and with symbols it usually is easier to follow current paths through the parts. As a consequence, practically all electrical diagrams make use of symbols.

WHAT EACH SYMBOL MEANS

Because the symbols shown on the two pages of symbols and pictures are used in so many electrical diagrams you should become well acquainted with the meaning of each of them. The following explanations tell just what each symbol signifies.

Wires Crossing (Not Connected): Wires which are not electrically connected together, but which must cross one another in a diagram, are shown by any of these symbols. The left-hand symbol generally is preferred, especially in engineering work, but the one at the right indicates the crossing most clearly.

Wires Joined or Connected: Wires which are electrically connected together, so that current may flow from one to the other, are shown by these symbols. Note that a small black dot indicates the point of joining.

Switch, Open Circuit: This symbol may indicate a press-button switch or other type normally held open by a spring, and closed by pressing a button or a lever. The switch opens again when the button or lever is released. The circuit in which the switch is connected normally remains open. This type may be called a normally open switch.

Switch, Closed Circuit: This is a switch normally held closed by a spring, and opened by pressing a button or operating a lever. The circuit in which the switch is connected normally remains closed. This type may be called a normally closed switch.

Switch, Double Circuit: This switch has three wire terminals, one connected to the movable blade of the switch, another to the contact point with which the blade is held in contact by a spring, and the third connected to the contact which normally is separated from the movable blade. A circuit normally remains closed between the movable blade and one contact point, and upon pressing the button or lever the connection is shifted to the other contact. This may be called a two-way switch.

Switch, Double Throw: This switch will connect one wire or one line to either of two other wires or lines, depending on which direction the switch handle or blade is moved.

Lamps: Either of these symbols may be used for any style of incandescent lamp. If some other style of lamp is to be indicated, such as a fluorescent type, a note to that effect should be made on the diagram, or else some special symbol should be used and plainly identified.

Cells: A cell is a single unit that produces emf and causes current to flow in a closed circuit. The longer line usually indicates the positive terminal of the cell, although this is not an invariable rule.

Battery: A battery consists of two or more cells which, when connected together in series as indicated by the symbol, deliver more emf or more voltage than a single cell. While the end of the battery shown by the longer line usually is considered to represent the positive terminal, it is better practice to mark the ends with plus (+) and minus (−) signs for polarity. The number of cells shown in the battery symbol does not necessarily indicate the number of cells in the actual battery. A few long and short lines may indicate any number of cells. One end of the symbol may be a long line and the other a short line, both ends may be long lines (this is good practice), or both ends may be short lines.

Transformers: Transformer windings may be indicated either with zig-zag lines or with loops. The zig-zag lines are preferred in commercial and industrial power and light circuits, while the loops are generally used in radio circuits. When using looped lines for the windings, one or more straight lines between the windings indicate an iron core. The absence of such straight lines means an air core. An iron core is assumed when using the symbol consisting of zig-zag lines, since power transformers always have iron cores.

Resistor, Fixed: A fixed resistor is one whose resistance cannot be altered while the resistor is in a circuit and is carrying current. The left-hand symbol, appearing like a dovetail joint, is the one used for resistors in commercial and industrial

power circuits. The saw-tooth or zig-zag line is used for resistors in radio circuits. Provided there is no danger of confusing the resistor symbol with the one for transformer windings, the saw-tooth symbol may be used to indicate resistors in any circuit.

Resistor, Adjustable or Variable: An adjustable or variable resistor is one whose value in ohms, or whose resistance, may be altered while the resistor is in use and is carrying current. An adjustable resistor may be called a rheostat. These devices are used for adjusting or varying the voltage and current going to some piece of electrical equipment or to a circuit.

Meters: All kinds of meters are indicated by circles within which are letters identifying the kind of meter. In addition to the symbols shown, a circle with an inclosed "F" would indicate a frequency meter, one with "WH" would indicate a watt-hour meter, one with "MD" would indicate a maximum demand meter, and so on.

Direct-current Machines: Direct-current generators and motors are indicated by circles which represent their commutators, and with diagonal lines which represent the brushes. Without a letter in the circle the symbol usually means a generator or dynamo, although it is common practice to place a "G" within the circle to prevent possible misunderstanding. The letter "M" within the circle indicates a motor.

Alternating-current Machines: An alternator or alternating-current generator is indicated by two concentric circles representing the slip rings and by sloping lines that represent the brushes or collectors. There are so many varieties of alternating-current motors that the symbol is simply a circle with the letter "M" inside. The general type of circuit, the connected wires, and other equipment in the circuit will help to identify many of these simple symbols and to avoid confusion. As an example, there would be three wire connections running to a three-phase alternating-current motor.

Fixed Capacitor or Condenser: An electrostatic condenser is commonly called simply a condenser. Capacitor is the better name, because there are many other kinds of condensers. The left-hand symbol, consisting of two parallel lines, is the one generally used in radio work. The right-hand symbol, indicating the interleaved plates and dielectric of the capacitor, is generally used in commercial and industrial circuit diagrams.

Variable or Adjustable Capacitor or Condenser: Either of these symbols indicates a capacitor whose value or whose capacitance may be altered or changed while the capacitor is working in a live circuit. Both of these symbols originated in radio work, since it is only in this and similar fields that adjustable capacitors are generally used.

Inductor, Reactor or Choke Coil: Any coil or winding which possesses considerable self-inductance and inductive reactance may be shown by these

symbols. The looped lines are the standard symbols for inductors or coils both in power diagrams and in radio diagrams.

Ground Connection: A ground connection is a connection either to a conductor that leads into the earth, or to the metallic framework and supports that carry electrical equipment. Two or more ground connections shown by symbols in the same diagram are assumed to be for the same ground, so that there is a continuous conductive path between the grounds shown on the diagram.

Signals: The symbols for bells, buzzers and annunciators are among those most commonly found in wiring diagrams. Other signal symbols will be shown on later sheets of symbols.

Relay: A relay is a switch whose contacts are operated by an electromagnet in which flows current that controls the relay. The contacts are in the same or a separate circuit. Relays often are shown by an outline having the shape of the part to which wire connections are made, and on which the relative positions of terminals are clearly shown.

KINDS OF ELECTRICAL DIAGRAMS

Before commencing the actual reading of electrical diagrams you should understand that different kinds of diagrams are intended for different purposes. Some diagrams are especially helpful when you are installing and wiring electrical apparatus, while others are arranged to help you locate and remedy circuit troubles. Some diagrams show only the external wires and connections between exposed terminals of electrical parts, others show the connections inside the parts.

In this book are many diagrams of each kind. To help you recognize their particular purposes and applications we now shall examine some examples of each kind.

EXTERNAL AND INTERNAL DIAGRAMS

Some electrical diagrams show the wires and other conductors through which electric current may flow, or should flow, as it travels from the exposed terminal screws and fastenings on each piece of electrical equipment to the exposed terminals of other pieces in the same circuit or same installation. A diagram of this general type appears on page 63 where you may see all the wires running between lamp outlets, switches, and other parts of the lighting installation for a small bungalow.

Other electrical diagrams show conductors and current paths through the parts which are inside some one electrical device. Diagrams of this type are shown on pages 45 and 46, where it is easy to trace the current paths through windings and contacts that are inside the relays.

Still other diagrams show both internal and external connections, or may show the internal connections for only some of the parts, and the external connections between all of them. Diagrams of this class are on page 47. On this page the diagrams show all the external connections between all the

parts, they show the internal connections inside the relays, but they do not show the internal connections for the signal bell in the upper diagram nor of the motor in the lower diagram.

As you have just seen, it is possible to have a diagram showing only external connections, possible to have one showing only internal connections, possible to have one showing both external and internal connections, or possible to have one showing some external and some internal connections. The kind of diagram furnished on any job depends on what work you are to do—on whether you are to work only on the external wiring, only on the internal connections, or on both.

WIRING DIAGRAMS

When we speak of an electrical diagram as a **wiring diagram** we usually mean that the diagram shows exactly how wires are to be placed between electrical parts, and just where each wire is to be connected.

On page 65 are wiring diagrams showing the outline shapes of a meter box and a service box. On these boxes are shown the exact positions and connections for the black or red wires (B or R) and for the white wires (W). Anyone able to use screwdriver and pliers should be able to install wiring with the help of such a **wiring diagram**.

The uppermost diagram on page 64 is a **wiring diagram** because it shows for the electric range the true relative positions of its burners, switches and other parts, and shows the actual locations of wire terminals on these parts. Were you looking at the range itself you would find that this diagram is practically a picture of the wires and terminals.

CIRCUIT DIAGRAMS OR SCHEMATIC DIAGRAMS

Running all the way across page 64, immediately below the large wiring diagram for the electric range, are two smaller diagrams. One is marked "Circuit for Cooking Unit," the other "Circuit for Oven Unit." These are not wiring diagrams, because the heater elements, switches and connections are not in the relative positions that they actually occupy on the range. But, on these **circuit diagrams**, it is easy to trace the paths for electric current all the way from the three main wires marked L, N and L through the switches and through the resistors which are heating elements, and back to the main wires. This style of diagram shows the paths for current very clearly, but does not place the parts in their true relative positions. A **circuit diagram**, which shows electrical circuits, may also be called a **schematic diagram**, because it shows the general scheme of things from the standpoint of electrical action.

It is plain that if you wish merely to check the connections of wires to the terminals of this electric range you will prefer to work with the large **wiring diagram** at the top of the page. But should one burner fail to operate and should you wish to check the paths through which the resistor in this burner

gets its current, then it will help greatly to have a **circuit diagram** or **schematic diagram** showing just how the switches operate, and just which resistors should be carrying current for each of the several degrees of heat. At least it would save much time provided you knew how to read a circuit diagram. Before we get through with our studies you will know how to read every such diagram and will be able to correctly interpret its meaning.

As a general rule the more expert and experienced the electrician the more he prefers to have circuit diagrams or schematic diagrams, and the less he depends on wiring diagrams. After getting acquainted with electrical apparatus in a general way, and when you have a particular piece of apparatus right in front of your eyes, it is not difficult to follow the wiring between exposed terminals. But no one can follow internal wiring without either taking the thing apart or having a good circuit diagram. With such a diagram it becomes easy to test for opens, high resistances, shorts and grounds by connecting your circuit tester to the exposed terminals—and to know from test indications just what is wrong inside the part on which you are working.

PICTORIAL DIAGRAMS

Sometimes a wiring diagram is a **pictorial diagram**, meaning that it consists of pictures showing the external appearance of the parts and of the wiring connections between them. On page 64, in the lower left-hand corner, the range installation diagram is a pictorial diagram. This diagram shows pictures of how conduit (pipe for enclosing wires) and armored cable (flexible metal covering for wires) are to be run between the electric range, the meter box, the switch box, the ground connection, and the outdoor service connection for the wires of the electric power company.

COMBINATION DIAGRAMS

Wiring diagrams, circuit or schematic diagrams, and pictorial diagrams all have their particular uses. But often more useful than any of them is a type which we may call a **combination diagram**. Such a diagram is partly pictorial and partly a circuit or schematic diagram. The telephone diagrams on pages 51, 52 and 53 are combination diagrams.

Consider the diagram on page 51. Here you may follow the internal connections through the windings in the symbol for a transformer, whose terminals are marked S-S-P-P, also through the electromagnet windings of the bell shown toward the right from the receiver, and you may follow the current paths through the contacts of the receiver hook switch. But internal circuits are not shown for the transmitter or mouthpiece at the extreme left-hand side of the diagram, nor for the receiver which you place to your ear, nor for the ringer magneto which is up near the line terminals at the right.

In this diagram on page 51 we have symbols for the transformer, the battery, and the ground

connection inside the magneto. We have simplified pictures for the transmitter and receiver. For the receiver hook switch, the bell, and the switch on the magneto we have a combination of picture and circuit diagram.

Excellent examples of combination diagrams are the meter connections shown on page 65. The meters themselves are shown by outlines with the windings inside the meters shown by loops connected to terminals which are in the positions they actually occupy on the meter basis. The fuses are shown very much as they actually look, either when looking at their tops or their sides. The shaded parts near the fuses are the connection straps, copper bars into which thread the terminal screws for wire connections.

In these diagrams on page 65 you have enough of a picture of the meters and the meter boxes to let you recognize every part of the actual equipment, and in addition you have all the internal wiring and the external connections so that every current path is easy to trace.

READING THE DIAGRAMS

Now that you have become familiar with many of the principles of all electrical diagrams we shall proceed to examine, one by one, each page or each diagram in the following section on "Wiring." In nearly every diagram or on nearly every page are examples of methods and practices generally followed. As you become acquainted with these practices you gradually will build up your ability to read and understand all electrical diagrams. Someday soon you will wonder why any of them ever appeared so complicated and intricate.

PAGE 41

This page shows a circuit tester consisting of battery, lamp and flexible wire leads, used to determine the type of switch being tested. In diagrams A, C and D there are arrowheads on the ends of the leads from lamp and battery, indicating that these leads are tipped with metal prods which may be touched to terminals being tested. Test leads may be shown as straight wires (diagrams A and B) but more often are shown by wavy lines (diagrams C and D) to indicate that they are flexible wires easily moved about. The types of switches are shown by their symbols.

PAGE 42

In tracing current paths through a diagram the directions of current flow may be indicated by arrowheads on the lines which represent wires. When a switch is shown as open on the diagram, but must be closed to permit current flow, the closing is indicated by a dot placed alongside the switch symbol. These practices are followed in Coyne School shops.

PAGE 43

The voltmeter, ammeter, battery and switches are indicated by their symbols. The voltmeter terminals carry flexible test leads tipped with metal prods,

as indicated by the arrowheads at the ends of the meter leads.

PAGE 44

Diagram A represents a water pump, water piping, and water pressure gauges connected to the piping. In the other diagrams the pump is replaced with an electric generator, the pipe with electric wires, the pressure gauges with voltmeters which measure electrical pressure, and the small section of pipe at the right-hand side is replaced with an electrical resistor.

In diagram B note that the negative (—) terminal of the generator is grounded. On the voltmeters represented at various points along the wire, one meter terminal is connected to the wire and the other terminal to ground. Thus one of the meter terminals always is connected through ground to the negative (—) side of the generator, and the meters will measure voltages at various points along the wire with reference to the voltage at the generator negative terminal.

In diagrams C and D the voltmeters are not grounded, but are connected through test leads to various points on the wire.

PAGE 45

In diagrams A, B and C connections from terminals O, M and C to the movable blade and the contact points are shown by broken lines. This indicates that these connections are made underneath the base of the relay. The coil or magnet connections shown by full lines are on top of the relay base where they may be seen.

Between diagrams A and B is a list giving meanings of letters used in the diagrams. In this list the part numbered 2 is identified as a spring, otherwise it might be taken for a resistor because of the manner in which it is shown in the diagrams. Parts with which there might be some confusion or doubt always should be identified on the diagram.

PAGE 50

In the lower diagram for an alarm circuit the bell armature, to which is attached the clapper that strikes the bell, is held toward the right so long as the switches remain closed to let battery current flow through the coils. Opening either switch opens the coil circuit, allows the armature to move to the right and make contact with the breaker screw, thus completing the bell circuit through the two ground connections and allowing the bell to ring continuously.

PAGE 54

The symbols at which we looked on earlier pages are those generally used for diagrams in which it is possible to trace the current paths throughout the entire electrical system. They are used for schematic diagrams and for circuit diagrams. This new page, Symbols for Wiring Plans, shows how the various electrical devices are indicated on diagrams for building wiring. Most of these symbols

are for various kinds of outlets. An outlet is a point on a wiring system from which is taken current for lamps, fixtures, appliances, heaters, motors, or any other electrical equipment.

The names printed alongside the symbols usually indicate quite clearly just what kind of outlet is meant. However, we shall follow down through the columns of the page and explain some points which may not be entirely clear.

A Capped Outlet is an outlet provided for possible future use, but at present closed with a screwed-on plate and having no external connections. A Junction Box is a steel or porcelain enclosure within which are joints between wires from different branches or runs in the wiring system, but to which lamps and other equipment are not connected. Vapor Discharge lamps include mercury vapor and fluorescent lamps as distinguished from incandescent lamps.

A Duplex Convenience Outlet is one to which two cord plugs may be connected at the same time. Convenience Outlets in general are outlets designed to take the prongs of the plugs on flexible cords. A Switch and Convenience Outlet is one that takes one cord plug and has in the same box a switch controlling current to the plug connections.

A Single Pole Switch opens and closes only one side of a two-wire line, while a Double Pole Switch opens and closes both sides. Three Way and Four Way Switches are used for controlling a single lamp or other equipment from two or more locations. An Electrolier is a lighting fixture having a number of lamps. A Circuit Breaker Switch is circuit breaker that operates automatically in case of excessive current, and that may also be operated by hand like an ordinary switch. A Momentary Contact Switch is one that makes and then quickly breaks a connection as the switch is operated.

PAGES 55 TO 57

Here are pages showing the connections and operation of switches such as generally used to control lighting and appliance circuits in buildings, as well as for any other controls which are similar.

The outlets controlled by the switches are represented by circles with four short lines radiating around the outside. The switches are shown by heavier circles. The switch terminals and stationary contacts are indicated by small black squares around the inside of the switch circle, while the contacts that are moved as the switch is operated are shown by lines between the terminals inside the switch circles.

On page 55 note carefully the differences between the symbols for single-pole, double-pole, three-way, and four-way switches. These symbols are used for their respective types of switches on the two following pages.

PAGES 58 TO 60

Now we are ready to examine plans for wiring a five-room bungalow. These first pages, 58 to

60, show how wiring contracts and specifications usually are written and how the electrical contractor figures his costs in great detail.

PAGE 61

This is a floor plan such as the architect furnishes for the electrical contractor or electrician. On the plan are marked, with symbols, the locations for all ceiling and side wall outlets, for all convenience outlets, and for all the wall switches that are to control current for the outlets. The plan shows the positions and construction of walls, and shows obstructions such as plumbing and heating equipment which might interfere with runs of wiring. Enough building measurements are shown to allow the electrician to figure out the lengths of all wiring required for the job. Now it is up to the electrician to lay out the wiring for greatest economy of material and labor, while complying with rules of the National Electrical Code or with local ordinances for wiring.

PAGE 63

This is the circuit wiring diagram prepared by the electrical contractor or the electrician. Compare the locations of all outlets and switches with those shown on the floor plan of page 61. Two circuits coming from the basement are shown entering this wiring diagram at the right-hand side. One circuit goes to the two bedrooms, their connecting hall, the bath room, the entrance hall, and to the second floor or attic. The other circuit goes to the kitchen, the basement stair light, the dining room and the living room. The loops placed around two conductors or three conductors at various places indicate that the conductors within a loop are run together inside a length of conduit or other form of raceway.

PAGE 64

The left-hand side of the upper wiring diagram shows connections in the oven unit of the electric range. There are two heater resistor units, marked "Lower Oven" and "Upper Oven," which are controlled by a single oven switch. Four switch terminals connect to the heaters, while three terminals connect through the thermostat and another resistor to the line terminal block.

Below the wiring diagram are circuit diagrams. The oven circuit diagram is toward the right. This oven unit circuit diagram shows the single switch in four different positions; off, pre-heat, bake and broil. Note that four leads run from the switch contacts to the heater resistors and that three leads run from the switch contacts to the line, just as in the wiring diagram up above.

The wiring diagram for the cooking unit (the "burners") is shown at the upper right. There are four resistor heating units and four switches, one switch for each unit. The circuit diagram for the cooking unit is shown below the wiring diagrams and toward the left. This circuit diagram shows one switch in its four different positions; off, high,

medium and low. The four switch diagrams apply to only one switch, any one of the four used. All four would operate in the same manner.

PAGE 66

The 2-wire meter (upper left) is used when only two service wires come to the installation from the power company lines. One of these wires is grounded in the power lines and is connected to the grounded neutral strap. There are two branch circuits or building circuits, marked "Load A" and "Load B."

The 3-wire meters (upper right and lower left) are used when there are three incoming service wires. One of these, called the neutral service conductor, is grounded in the power circuits and is connected to the grounded neutral strap. The voltage between the neutral and either of the other "outer" wires is 110-120. The voltage between the two outers is 220-240. Each building circuit, branch circuit, or load circuit has two wires. One of these wires is connected to the neutral and the other is connected to either one or the other of the outer wires. Thus each branch circuit has two wires with a voltage difference of 110-120, and one of them is grounded through the neutral grounds.

The three-phase meter is a type used on three-phase alternating-current power lines that supply power for large motors and other commercial and industrial equipment.

PAGE 67

This sheet shows a test that may be applied to building circuits and outlet connections after the installation is complete but before the regular service is connected. Any direct-current source furnishing 200 to 250 volts is connected at the meter socket or to the branch circuits where they start from the service entrance equipment. The negative of the source is connected to the grounded side or neutral side of the building circuits.







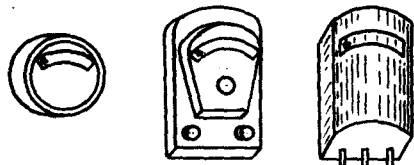
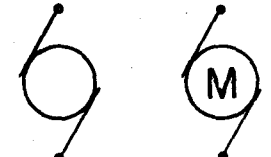
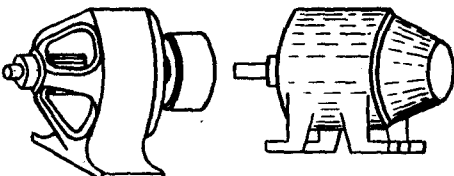
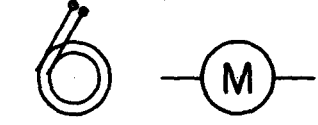
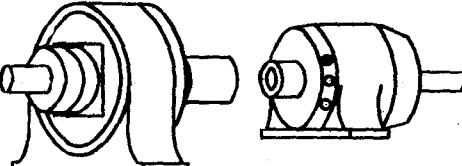
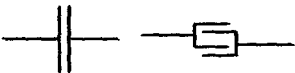

Each lampholder then is checked by means of a 200-240 volt neon lamp, which has a medium screw base like an ordinary incandescent lamp. This lamp has two plates or two "filaments." Only one of them will light or glow on direct current, and this will be the one connected through to the negative side of the d-c source. The lamp is first tested to see which plate glows when the screw shell of its base is connected to the negative side of the source, and the glass of the lamp is marked to identify this plate.

Screw shell lampholders are supposed to be so connected to the wiring that the shell connects to the grounded wire or the neutral wire and so that the center contact connects to the ungrounded side or "hot" side of the circuit. When the neon test lamp is screwed into a lampholder the identified plate will glow if the lampholder is correctly connected to the circuit wires. If the lampholder connections are reversed, the other plate of the test lamp will glow.

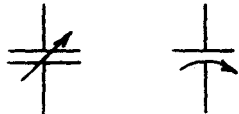
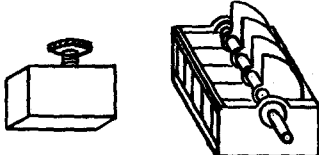
SYMBOLS USED IN WIRING DIAGRAMS

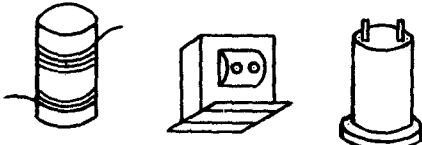
NAME OF PART	SYMBOLS	PICTURES
WIRES CROSSING (Not Connected)		
WIRES JOINED OR CONNECTED		
SWITCHES	<div style="display: flex; justify-content: space-around;"> <div style="text-align: center;"> Open Circuit </div> <div style="text-align: center;"> Closed Circuit </div> </div> <div style="display: flex; justify-content: space-around; margin-top: 10px;"> <div style="text-align: center;"> Double Circuit </div> <div style="text-align: center;"> Double Throw </div> </div>	
LAMPS		
CELLS One, of any type		
BATTERY Two or more cells		
TRANSFORMERS With iron cores	<div style="display: flex; justify-content: space-around;"> <div style="text-align: center;"> With two untapped windings </div> <div style="text-align: center;"> Tapped winding </div> <div style="text-align: center;"> Three windings </div> </div>	
RESISTOR, FIXED		
RESISTOR, ADJUST- ABLE OR VARIABLE RHEOSTATS		

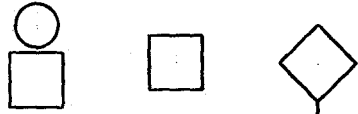
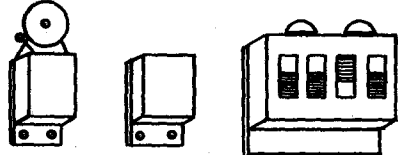
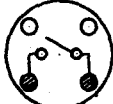
SYMBOLS USED IN WIRING DIAGRAMS

NAME OF PART	SYMBOLS	PICTURES
METERS	 <p>Ammeter Voltmeter Wattmeter</p>	
DIRECT-CURRENT MACHINES	 <p>Generator Motor</p>	
ALTERNATING-CURRENT MACHINES	 <p>Alternator Motor</p>	
FIXED CAPACITOR OR CONDENSER		
VARIABLE OR ADJUSTABLE CAPACITOR OR CONDENSER		
INDUCTOR, REACTOR OR CHOKE COIL	 <p>Air Core Iron Core</p>	
GROUND CONNECTION		
SIGNALS	 <p>Bell Buzzer Annunciator</p>	
RELAY		

IDENTIFYING SWITCH TERMINALS.

BEFORE WIRING ANY CIRCUIT that involves the use of switches, it is first of all necessary to test the switches themselves to make sure that they are the type required and that they are operating properly.

The test circuit consists of a source of power, a test lamp, and a couple of leads. When the test leads are touched together, the lamp should light. If the lamp does not light, there is something the matter with the test circuit.

Diagram A shows how to test a switch. Note that the leads from the test circuit are placed on the switch terminals. As this switch is normally open the light will not light until the switch button is pressed. If the switch lights the lamp when the button is pressed, two things are shown:

1. The switch is in operating condition
2. The switch is an open circuit type

Diagram B shows the test result on a switch that is normally closed. If the test lamp lights when the leads are placed on the switch terminals but goes out when the button is pressed, two things are shown:

1. The switch is in operating condition
2. The switch is a closed circuit type

Diagram C shows a double circuit switch. This is really two switches in one, for it is a combination of an open circuit switch and a closed circuit switch. To test this switch and find which terminals connect to the various parts, first find the two terminals that will give a light without pressing the switch. These two terminals must connect to the moving contact of the switch and the closed contact of the switch. The remaining contact must be the open contact. Mark O alongside this terminal.

Next find the pair of contacts that produce a light only when the switch is pressed; these will be the moving and open contact. As the open contact has already been found, the other contact must be the moving contact. Mark this terminal M. The third must be the closed contact. Mark it C. In this way, all of the switch terminals may be identified.

If the above indications cannot be obtained, the switch must be defective. Try another one. Always test switches before wiring them up in a circuit. In this way much time will be saved and, when the connection is properly completed, the circuit will operate.

M = MOVING CONTACT.
C = NORMALLY CLOSED CONTACT.
O = " OPEN "

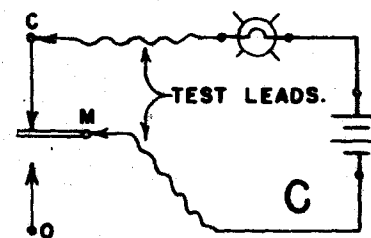
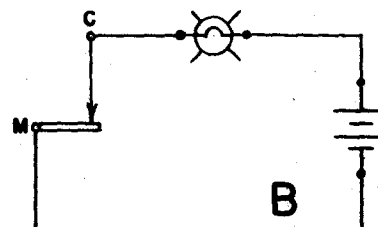
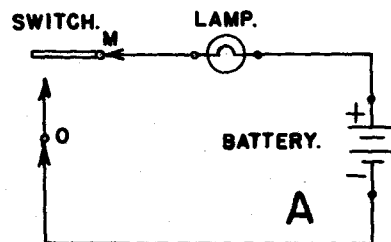

○ ○ ○

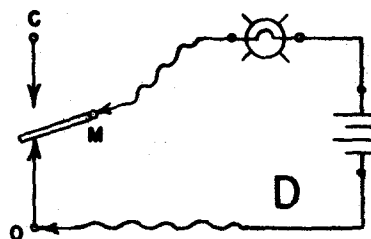

○ ○ ○

TRACING CIRCUITS.

THIS SHEET SHOWS HOW TO TRACE ELECTRICAL CIRCUITS, IF THE STEP BY STEP PROCEDURE GIVEN BELOW IS FOLLOWED, LITTLE DIFFICULTY WILL BE EXPERIENCED.

- a. Mark the polarity of the source of supply, putting a (+) mark at the point of highest electrical pressure, and a (-) mark at the point of lowest electrical pressure.

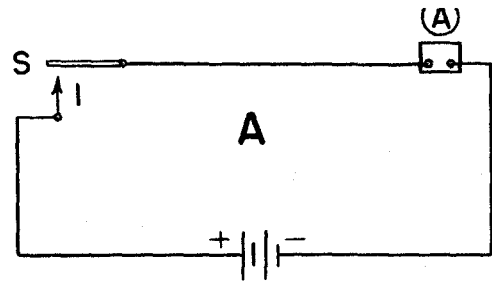

- b. See if there is a complete path from (+) to (-). In this case the path can be completed only by closing the switch S. To indicate that this switch is closed, place a dot beside it as shown.

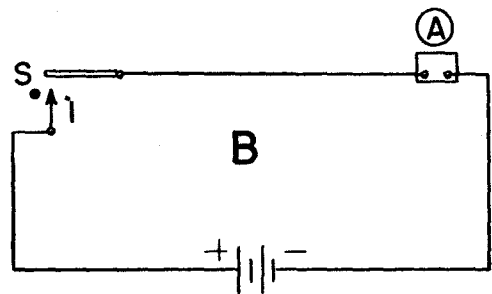

- c. Now trace the circuit, using the arrows to indicate the direction of current flow around the circuit from the high pressure point (+) to the low pressure point (-).
 d. Mark the number of the circuit alongside or inside the diagram and show the color of the arrow used to trace it thus:

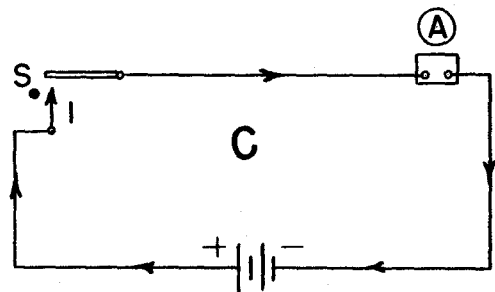

Circuit #1

- a. Mark the polarity of the battery (+) (-).

- b. Close switch #1 with a lead pencil dot, and trace circuit controlled by this switch in the same color.

- c. Mark number of circuit alongside diagram and show colored arrow used to trace it thus: Circuit #1

- d. Close switch #2 with a red dot and trace the circuit controlled by this switch in red.

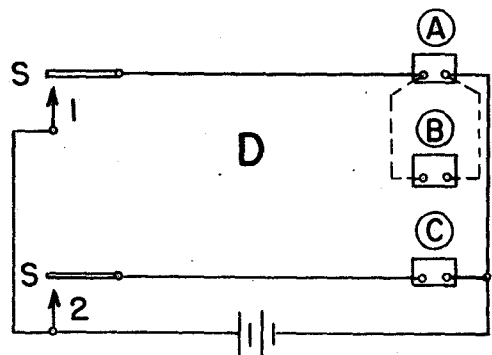

CIRCUIT No. 1

CIRCUIT No. 2

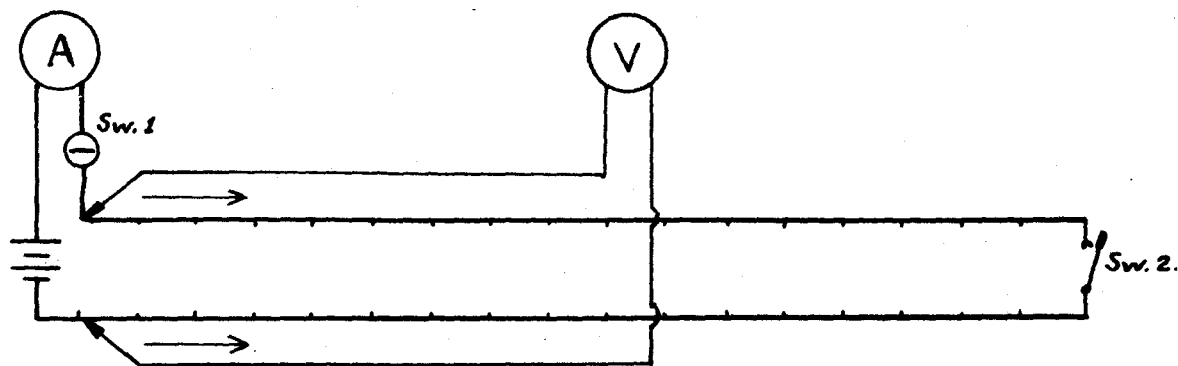

Experiment A:

Place the voltmeter leads as shown. With switch-1 closed and switch-2 open, draw the voltmeter leads slowly toward opposite end of the line and notice that the voltmeter does not vary because there is no current flowing.

Repeat the experiment with both switches closed and mark the voltmeter readings on the drawing at the dots. The dots indicate the points where the wire is stapled to the table. This will prove that when current is flowing in the wire the voltage drops as the length of line or the distance from current source is increased.

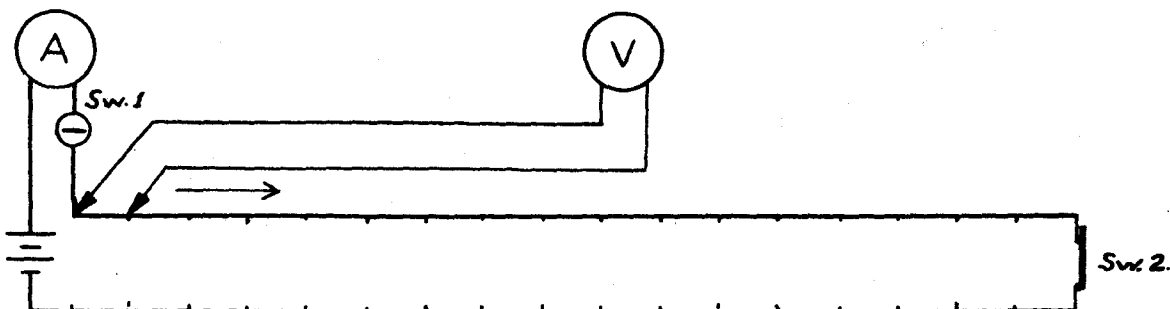

Experiment B:

With both switches closed place the voltmeter leads together on one of the wires, then slowly draw them apart. NOTE the voltage at different intervals marked. The VOLTAGE DROP increases with the length of the wire between the voltmeter leads.

Using this test determine the resistance of different lengths of the wire. Place the voltmeter leads at two points on the same wire and observe the voltmeter reading. Divide the voltmeter reading "E" by the current flowing "I" and the answer obtained is the resistance "R" of the wire between the two points.

Mark the voltmeter readings and the resistance between the points indicated by dots on the diagram.

VOLTAGE DROP IN THE ELECTRICAL CIRCUIT

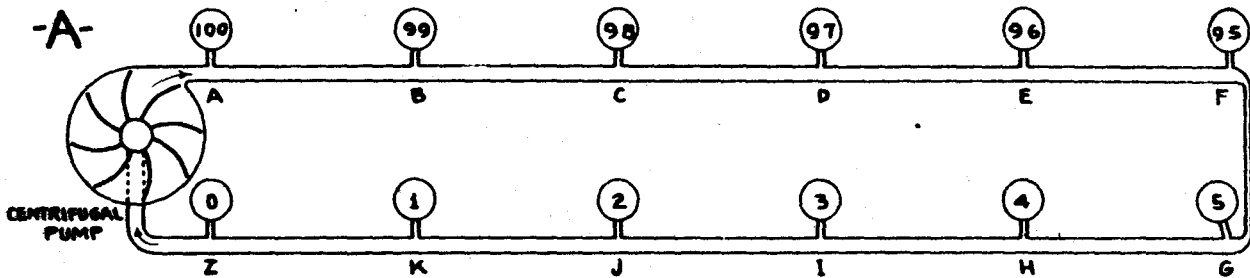

- 1 Which point is at the higher pressure? A or B, J or I, B or D, K or A.
- 2 What is the difference in pressure between A-B, B-D, C-F, F-G, F-J, A-Z?
- 3 What is the drop in pressure from A-B, C-E, F-G, H-K, E-H, E-G, D-I?
- 4 What is the total pressure drops around the circuit?
- 5 Is the sum of the pressure drops equal to the applied pressure?
- 6 What is the pressure rise in pounds from Z to A?

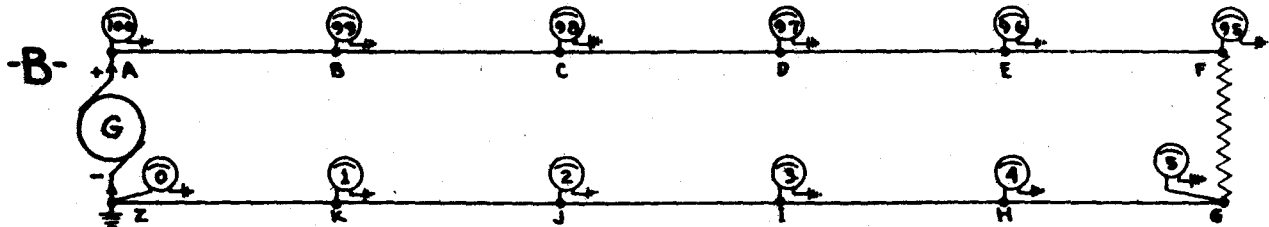

- 1 Which point is at the higher pressure? A or B, J or I, B or D, K or A.
- 2 What is the difference in electrical pressure between A-B, B-D, C-F, E-G?
- 3 What is the drop in pressure from A-B, C-E, E-F, F-G, K-Z, H-K, A-F, G-Z?
- 4 What is the sum of the electrical pressure drops around the circuit?
- 5 Is the sum of the pressure drops equal to the applied pressure?
- 6 What is the pressure rise in volts from Z to A?

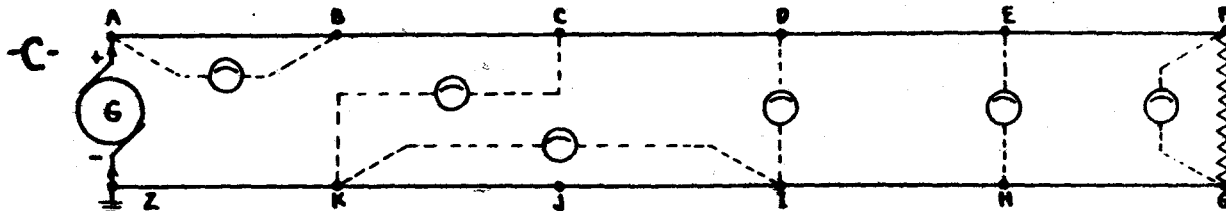

- 1 Assume same conditions as shown in (B).
- 2 What is the reading on each of the voltmeters? Note that each meter indicates the difference in pressure between the points to which it is connected. What is the sum of the "voltage drops" around the circuit?
- 3 What is the applied voltage? Does the sum of the voltage drops equal the applied voltage? Mark the readings of the different meters shown.

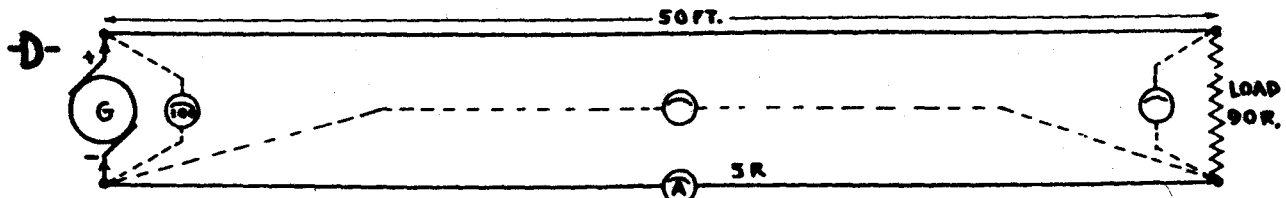

- 1 What is the rate of current flow in amperes?
- 2 What is the voltage drop per 10 feet of line? Res. of ten feet is one ohm.
- 3 What is the total line voltage drop?
- 4 What voltage is applied to the load?
- 5 Does the load voltage plus the line drop equal the applied voltage?
- 6 Mark in the readings on the different meters shown.

RELAYS.

A RELAY IS A MAGNETICALLY OPERATED SWITCH that can be used to:

1. Control circuits distant from the operating point.
2. Control a relatively high voltage or high wattage circuit by means of a low power, low voltage circuit.
3. Obtain a variety of control operations not possible with ordinary switches.

Whether the circuits controlled will be closed or opened when the relay coil is energized will depend upon the arrangement and connection of the relay contacts.

ACTION

When current flows through the relay coil, it magnetizes the iron core with a polarity that depends upon the connection of the coil to the source. This pole induces in the iron section of the movable assembly, a pole of opposite sign, and the attraction between these operates the relay switch. If the current through the coil is reversed, both poles are reversed; therefore attraction always occurs. From above it is obvious that relays can be designed to operate on either direct or alternating current.

It is important to note that while relays may vary widely in mechanical construction, they all operate on the same principle. The sketches on this sheet show some of the differences in design.

TESTING

Before any attempt is made to connect a relay in a circuit:

1. Make a sketch of the terminal locations
2. Test and identify all terminals
3. Make sure the relay is operating

Using an ordinary test lamp circuit, first find the pair of terminals that, when the test leads are placed on them, causes the relay to operate. These are the coil terminals. Identify them on the terminal sketch with the symbols CT. Next locate by test, inspection, or both, the open, moving, and closed contact terminals. Mark them on the terminal sketch with the symbols O, M, and C respectively.

After the terminals have been identified, check the operation. The relay should pull the movable section up as soon as the coil is energized, and drop it out as soon as the coil is deenergized. The moving section should not touch the core, and the tension on the spring should not be too low or too high. The relay switch contacts must be clean.

Connecting a relay in a circuit without first making the above tests is, in the general case, an inefficient and time-wasting

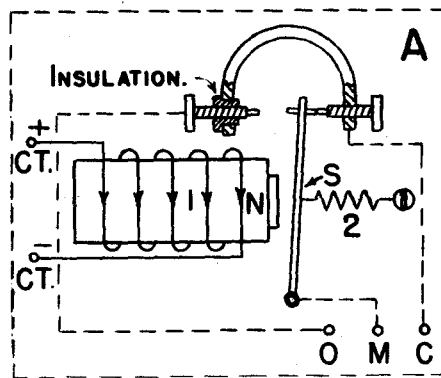

WESTERN UNION RELAY.

C = NORMALLY CLOSED CONTACT.
 O = " OPEN "
 M = MOVING CONTACT.
 1 = MAGNET COIL WITH TERMINALS CT.
 2 = SPRING.

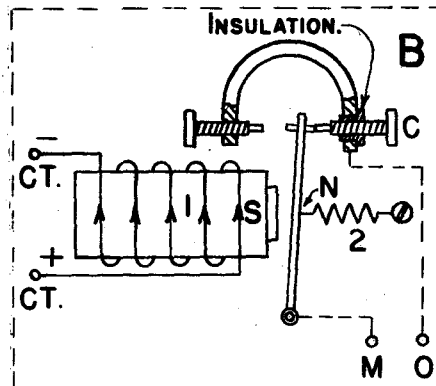

PONY RELAY.

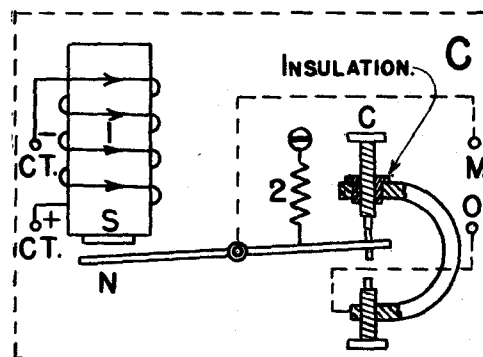

DIXIE RELAY.

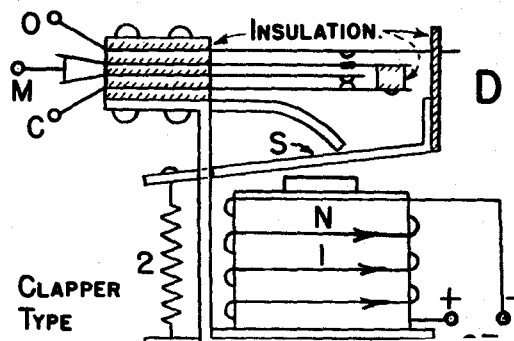

CLAPPER TYPE

RELAY CIRCUITS.

Diagram A shows an application in which a relay and a low voltage control circuit are used to operate a circuit carrying more power at a higher voltage.

To wire this circuit;

1. Make a note of the apparatus required.
2 open circuit switches; 1 relay;
1 lamp; 2 batteries.
2. Test all apparatus involved and select and use only that equipment that is in operating condition.
3. Wire each circuit one step at a time, and check each step before wiring the next.
4. Trace the circuits according to the method previously outlined.

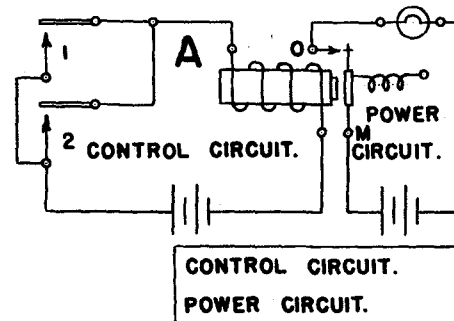

Diagram B shows a relay application similar to that indicated in A. In this case, however, the control circuit is normally closed, whereas in A the control circuit is normally open. The switches used are the closed circuit type. Note also that in diagram A the open contact of the relay switch is used in the power circuit, but that in B the closed contact is employed. The list of apparatus for this circuit will therefore be somewhat different than in the previous case. The procedure for wiring will be the same as before.

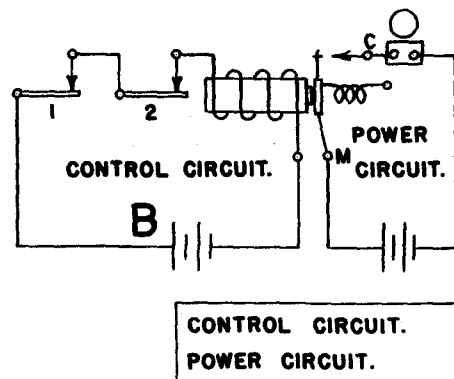
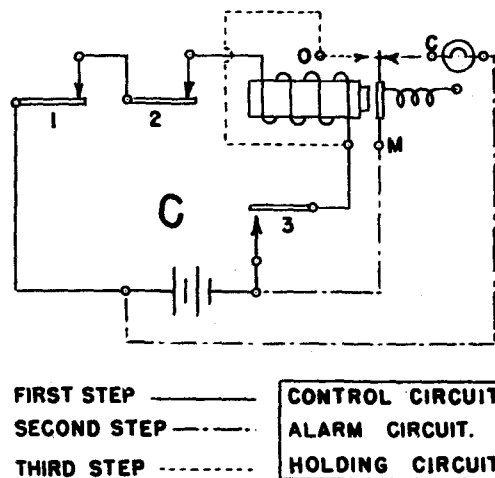
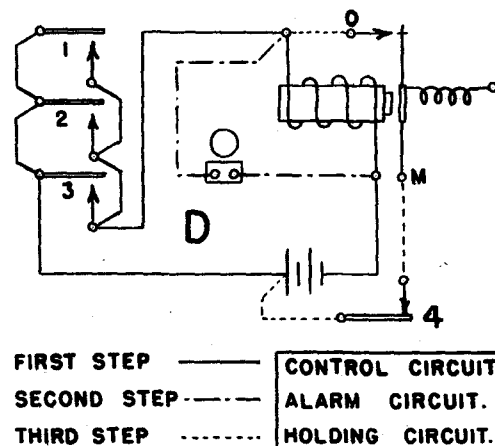

Diagram C shows relay applications in which a type of control not obtainable with ordinary switches is achieved. When switch 1 or 2 is pressed the relay switch closes the indicating circuit and the lamp lights and remains alight until switch 3 is pressed, when the relay is energized and stays that way until some other switch is operated.



Wire the circuit in 3 steps and test each before going on to the next. The first step is shown in solid lines, the second in dashed lines, and the third in dotted lines. Trace the circuits and show the color used in the boxed section.

Diagram D shows another relay being used to obtain a special type of control. Switches 1, 2, or 3 energize the relay and close the bell circuit through the relay switch. The bell rings continuously until switch 4 is pressed to reset the relay.



Wire a step at a time as directed in diagram C then trace the circuits and show colors used.

RELAY APPLICATIONS

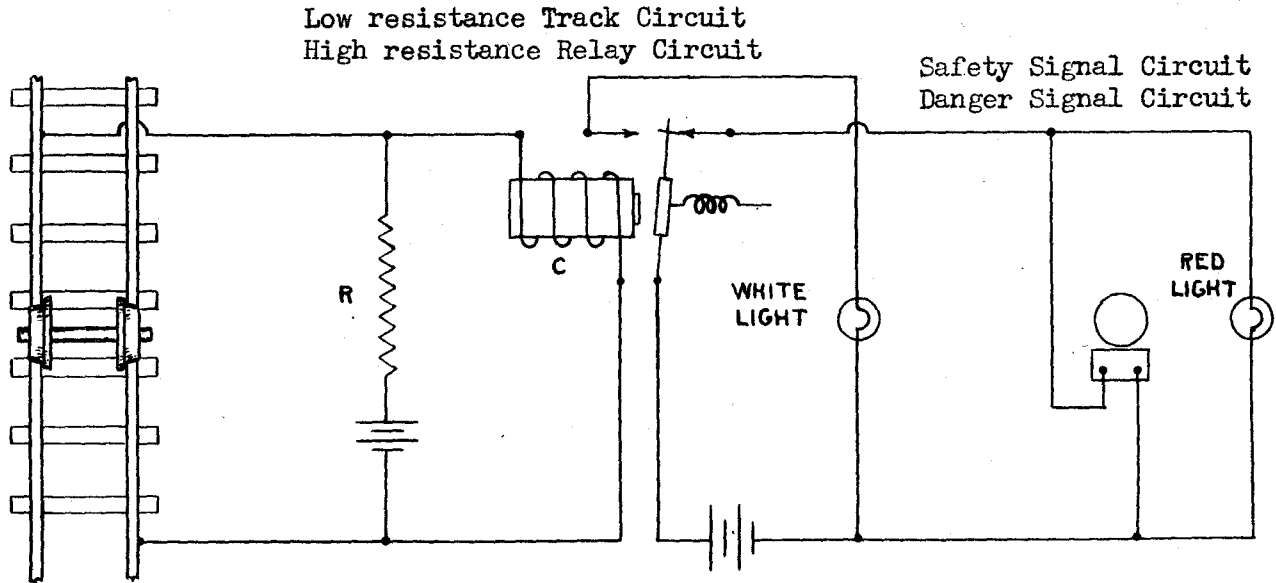

Railway crossing alarm system. When no train is on this section of the track, current will flow through the resistance "R" and the coil "C" of the high resistance relay. This will attract the relay armature, and complete a circuit through the open bridge contact and the white lamp, (clear signal.) When this section of track is shorted by the train wheels and axle, most of the current will flow through this lower resistance path, thereby greatly reducing the current through "C" and releasing the armature, closing the circuit to red lamp and bell, (danger signal.) An open circuit switch may be used in place of track on this job.

JOB 35

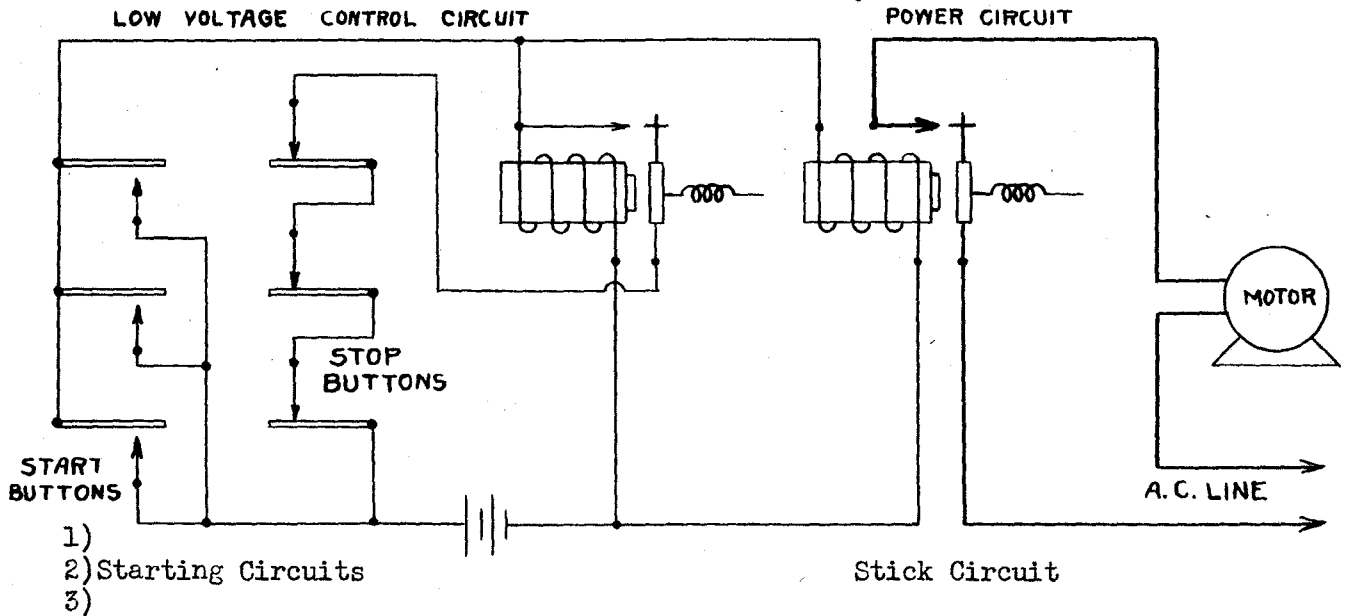

This diagram shows how a motor may be operated from several different places. Control systems similar to the above are often used to operate motors driving conveyors, printing presses, lathes, multiple drilling machines, and so on.

ANNUNCIATOR SYSTEMS

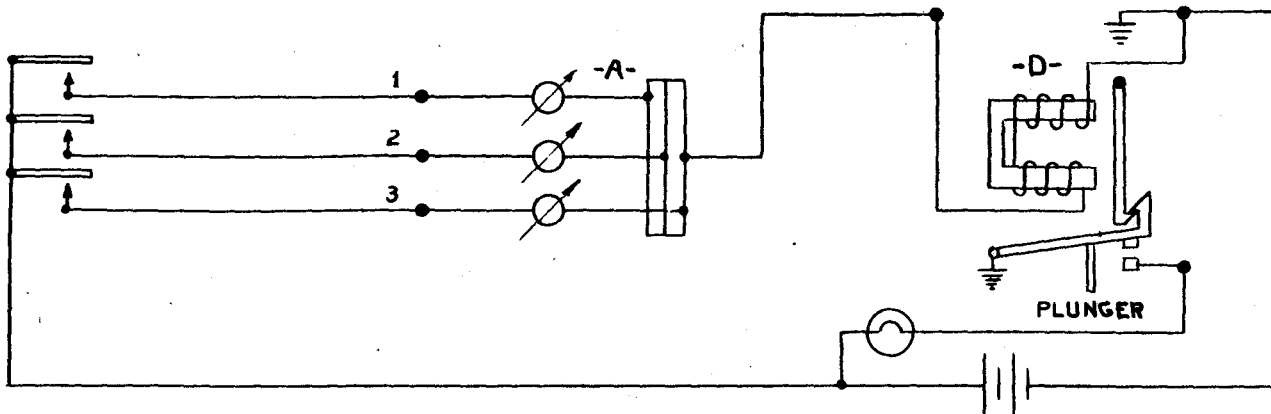

This is an alarm or signal system using an annunciator "A", and a drop relay "D" (drop switch) to provide a continuous alarm until the relay is reset by hand. Apply the following tests to locate terminals on drop relay.

- (1) Be sure the drop relay is set. The little plunger must be pushed up as far as it will go, so that the drop contacts are held apart.
- (2) Test with test leads until you locate the two terminals which, when connected, will trip the relay. These terminals will be the grounded coil terminal and the insulated coil terminal. The remaining terminal will be the drop contact terminal.
- (3) To distinguish between the two coil terminals, connect one lead to the drop contact terminal with the relay tripped and one lead to one of the coil terminals. The insulated coil terminal, when connected, will pull the relay armature over with a click. The other coil terminal will be the grounded coil terminal.

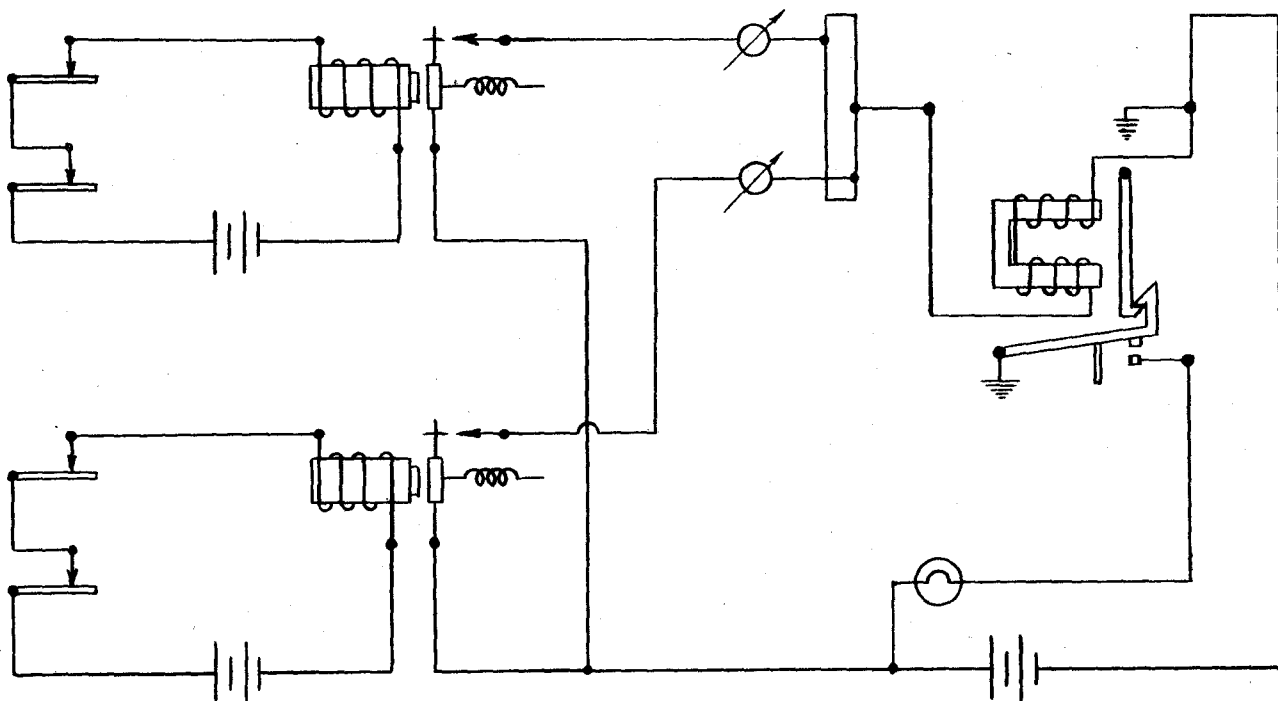

This is a two-section alarm or signal system. Two or more floors, buildings, or departments can be protected in this manner. The annunciator indicates which floor or building the call comes from and the drop relay gives a continuous indication after the system has been disturbed. A bell can be used in place of the lamp if an audible signal is desired.

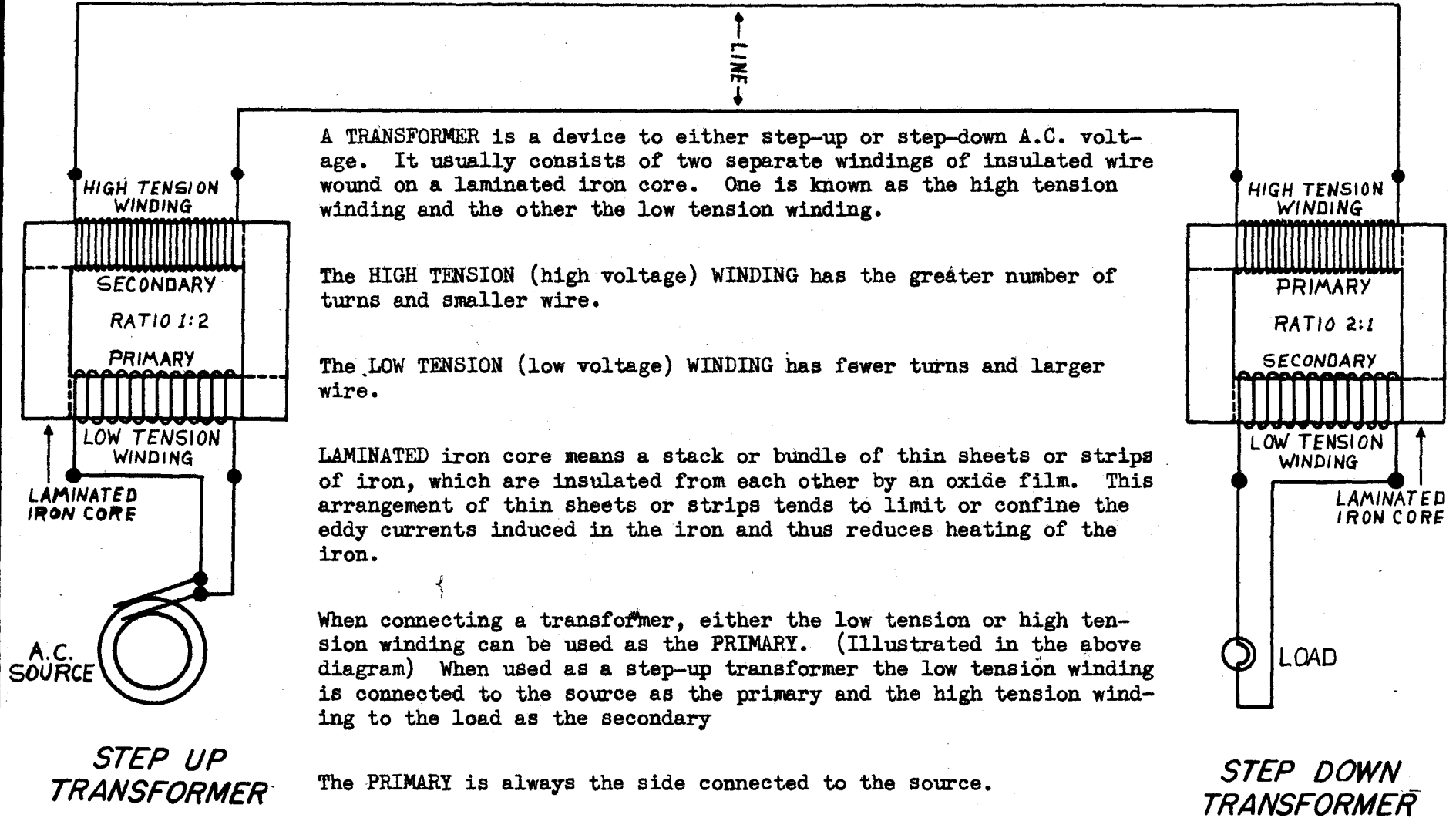

A TRANSFORMER is a device to either step-up or step-down A.C. voltage. It usually consists of two separate windings of insulated wire wound on a laminated iron core. One is known as the high tension winding and the other the low tension winding.

The HIGH TENSION (high voltage) WINDING has the greater number of turns and smaller wire.

The LOW TENSION (low voltage) WINDING has fewer turns and larger wire.

LAMINATED iron core means a stack or bundle of thin sheets or strips of iron, which are insulated from each other by an oxide film. This arrangement of thin sheets or strips tends to limit or confine the eddy currents induced in the iron and thus reduces heating of the iron.

When connecting a transformer, either the low tension or high tension winding can be used as the PRIMARY. (Illustrated in the above diagram) When used as a step-up transformer the low tension winding is connected to the source as the primary and the high tension winding to the load as the secondary

The PRIMARY is always the side connected to the source.

The SECONDARY is always the side to which the load is connected.

The VOLTAGE INDUCED in the secondary will depend upon the ratio of turns and the voltage applied to the primary.

TO BE WIRED AND CHECKED AT TABLES

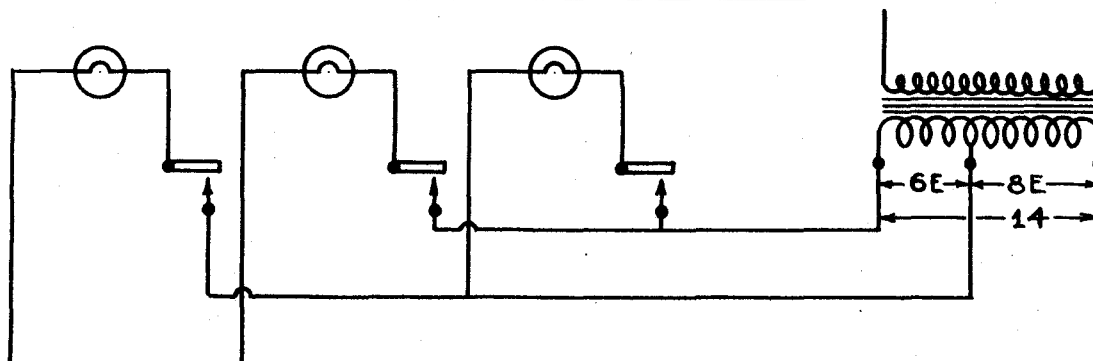

This diagram shows how lamps may be connected to light on different voltages. These are obtained, on this job, by using a step down transformer having taps for 6, 8, and 14 volts. Notice the primary side of the transformer is already connected to the 110E source. You are connecting to the secondary taps only. Other voltages can be obtained from other transformers.

What two factors determine the voltage induced in the secondary?

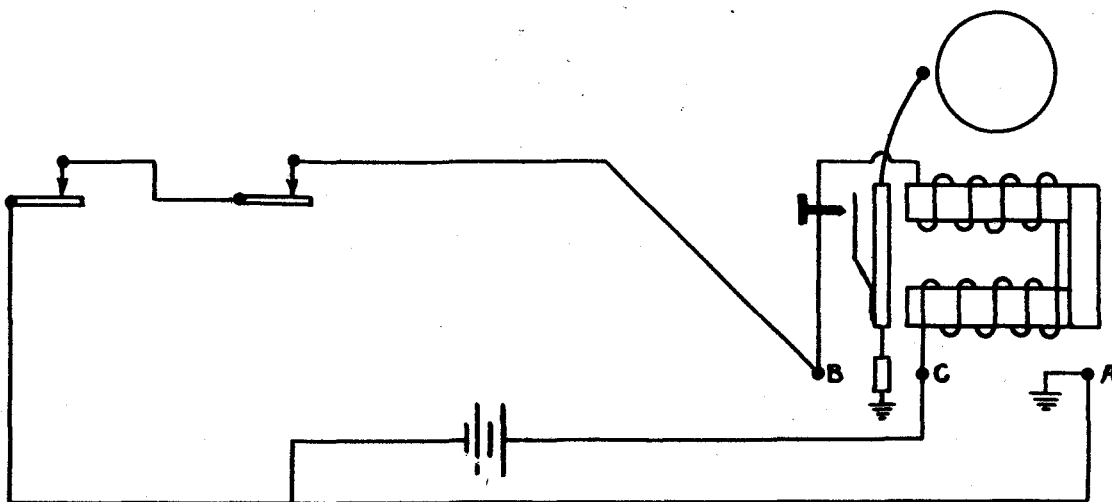

This is a simple economical closed circuit alarm or signal system for protection of garages, poultry houses, etc. It uses a high resistance bell, with an extra connection to the breaker contact, a closed circuit battery (storage battery), and closed circuit switches.

Make the following tests to locate the terminals on a bell:

Place your test leads on any two terminals and if the bell vibrates (rings), the test leads are on the coil and armature terminals. The other is the extra breaker terminal.

Now, move one of the leads to the breaker terminal, - if the armature is pulled over and strikes once (single stroke) the leads are on the coil and breaker terminals, but if you get a short circuit the leads are on the armature and breaker terminals.

LOCAL BATTERY TYPE TELEPHONE - SILENT RINGING

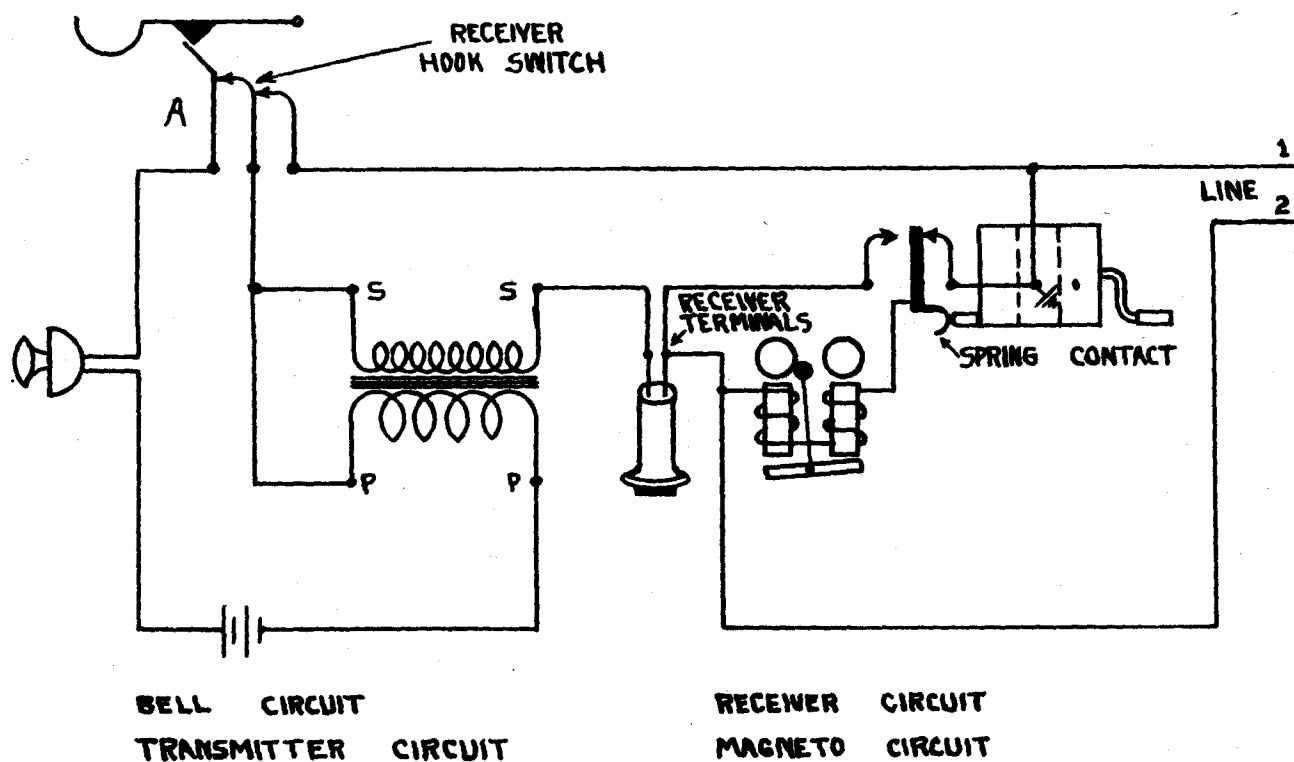

Observe that when the receiver is off the hook, as shown in the above diagram, all of the contacts on the hook switch (at "A") are closed, thus completing both the receiver circuit to the line and the transmitter circuit.

Hang the receiver back on the hook. Notice that all of the contacts open, thereby breaking receiver and transmitter circuits. This type of telephone is called silent ringing because, by turning the crank on the magneto to call out, the bell is shunted and does not ring.

The reason for this can be clearly seen when turning the crank. The mechanical arrangement of the shaft moves the moving contact of the double-circuit switch, on the end of the magneto, away from the closed contact over against the open contact.

This type of telephone can be used on a grounded line by connecting line "2" to the earth and line "1" to a wire extending to the other telephone. It can also be used on metallic line by connecting one wire of the line to line "1" and the other to line "2".

It should be noted that the pulsations in the battery circuit produced by operation of the transmitter result in alternating voltages being induced in the secondary winding of the transformer and that these A.C. voltages force A.C. currents through the line which operate the receiver at the other end.

The magneto shown is also an alternating current device. This explains the need for using a polarized bell on this unit, since positive ringing cannot be satisfactorily obtained on a bell of the ordinary type when it is operated from an alternating current source.

LOCAL BATTERY TYPE TELEPHONE

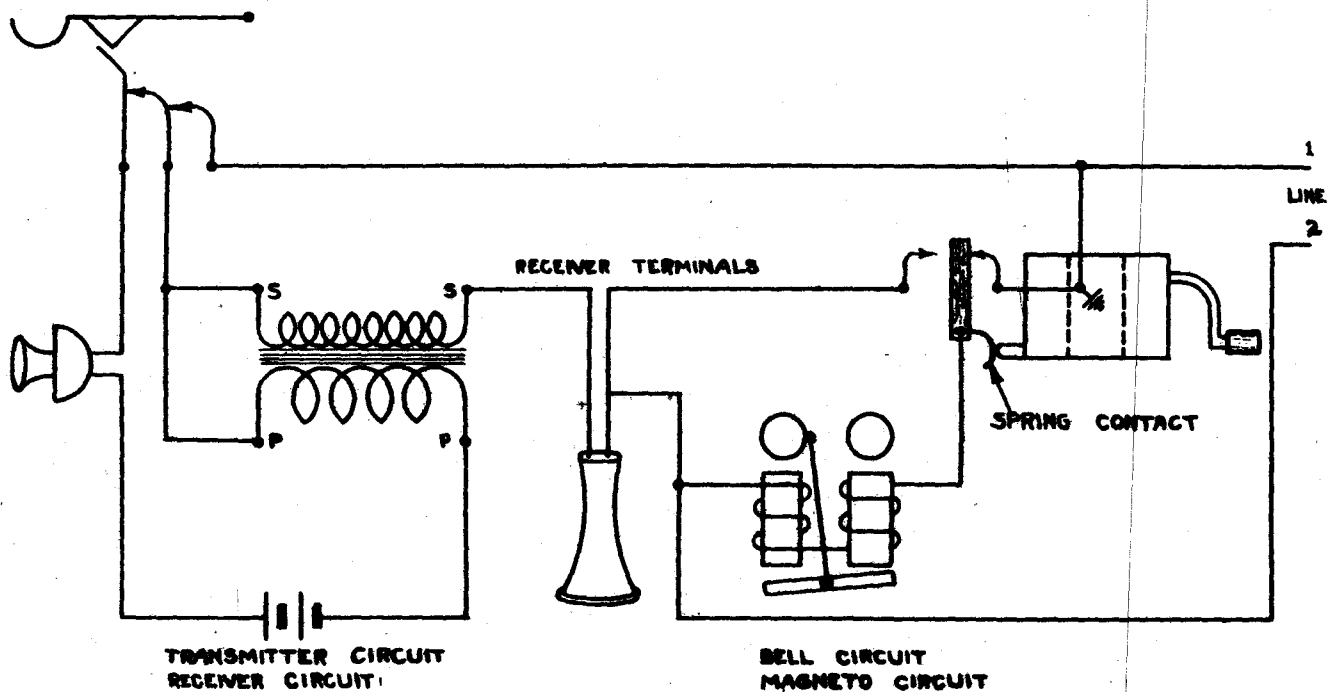

CENTRAL ENERGY TYPE TELEPHONE

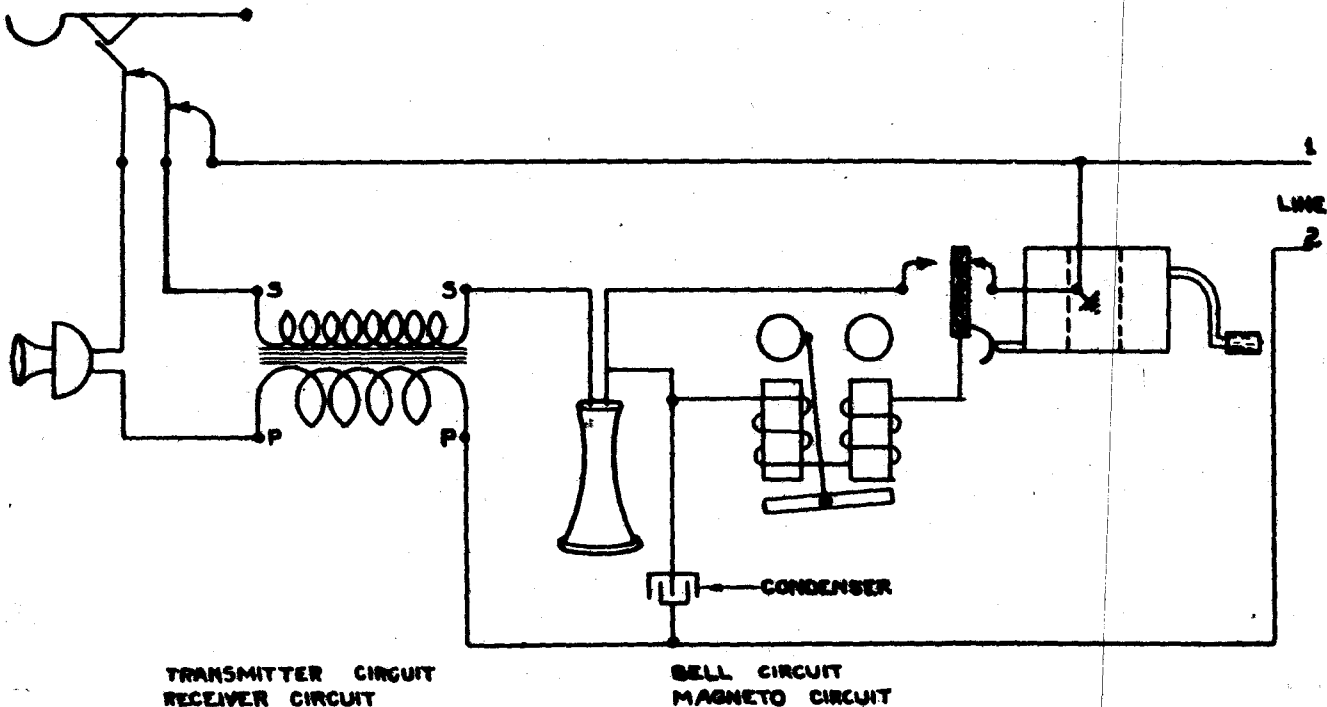

This is a comparison of Local Battery Telephone, and the Central Energy Telephone each with a magneto ringer.

The purpose of the condenser in the Central Energy Telephone is to prevent the D.C. of the transmitter circuit flowing through the receiver circuit, but still permitting the A.C. for ringing and the receiver circuit.

When ringing is done from a central source the magneto will not be necessary. Instead of connecting the polarized bell to the moving contact, connect it direct to line 1 and eliminate the connection from the receiver to the open contact on the magneto.

ELEMENTARY DIAGRAM OF THE TELEPHONE

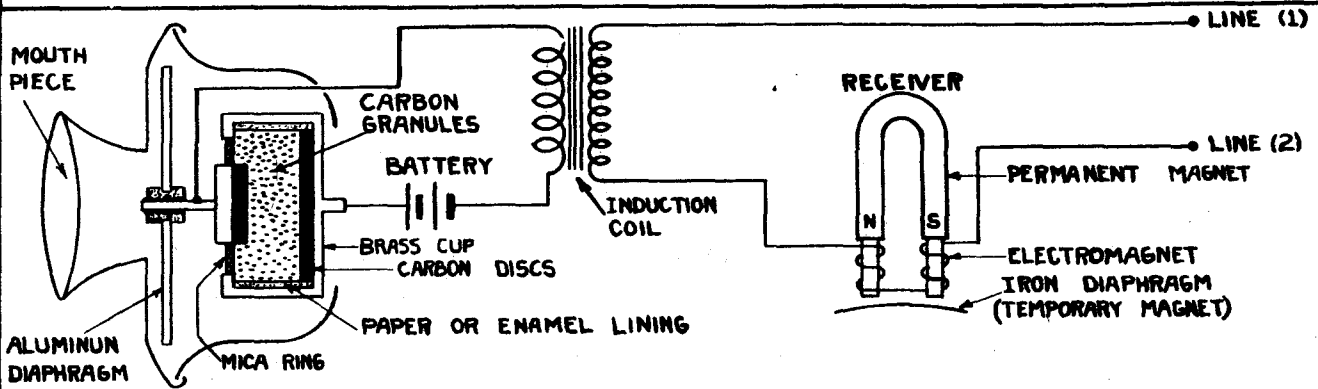

The above diagram shows the equipment and connections for one telephone. Connection can be made to another telephone through points indicated Line "1" and Line "2". The transmitter button is everything enclosed in the brass cup. Sound waves (voice waves), through the mouthpiece, strike the aluminum diaphragm, causing it to vibrate. These vibrations move the front of the transmitter button in and out, which tightens and loosens the carbon granules. This decreases and increases the resistance of the transmitter circuit, thus affecting the value of the current through the primary side of the induction coil. The effect of the change in rate of current in the primary induces an alternating voltage in the secondary, which causes current to flow first one direction then the other through the receiver circuit. A.C. in the electro-magnets, which varies the strength of the permanent magnet and causes the iron diaphragm to vibrate. These vibrations of the receiver diaphragm, which means that the sound waves thus produced by the receiver diaphragm are a reproduction of those impressed on the transmitter diaphragm.

The diagram shows conditions as they exist when the receiver is off the hook. Ordinarily the receiver hook-switch opens the transmitter circuit to prevent drain on the battery, and also opens the receiver circuit. Notice there is nothing magnetic about the operation of the transmitter. Its purpose is purely to convert sound waves to electrical impulses, producing PDC in the transmitter circuit. The receiver operates on the magnetic effect of current. It demonstrates the application of the three artificial magnets - namely - permanent magnet, temporary magnet, and electro-magnet.

POLARIZED BELL

OPERATES ON A.C.

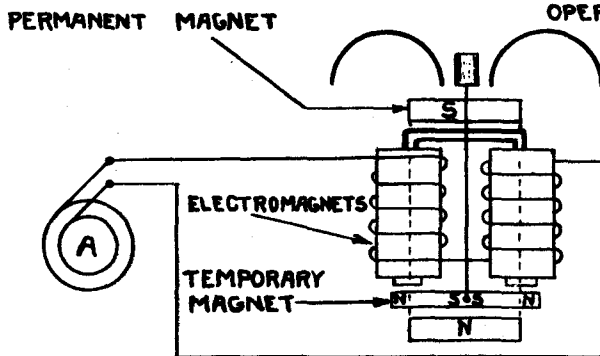

The polarized bell is the device commonly used in connection with the telephone to sound an audible alarm when calling. It requires a source of energy separate from the transmitter circuit and receiver circuit.

The N-pole of the permanent magnet indicates the consequent poles "S" and "S" in the soft iron bar, making the main poles both N-poles. The iron bar is pivoted in the center, which permits its ends to move up and down when attracted or repelled as A.C. changes the polarities of the electro-magnets.

By tracing the circuits for each alternation separately, it will be seen that the "right-hand rule for electro-magnets" applies here; also the "First Law of Magnetism."

SYMBOLS FOR WIRING PLANS

GENERAL OUTLETS	CEILING	WALL
Outlet	○	○
Capped Outlet	⊙	⊙
Drop Cord	Ⓓ	
Electrical Outlet—for use when confused with columns, plumbing symbols, etc.	Ⓔ	Ⓔ
Fan Outlet	Ⓕ	Ⓕ
Junction Box	Ⓖ	Ⓖ
Lamp Holder	Ⓖ	Ⓖ
Lamp Holder with Pull Switch	Ⓖ _{PS}	Ⓖ _{PS}
Pull Switch	Ⓐ	Ⓐ
Outlet for Vapor Discharge Lamp	⒱	⒱
Exit Light Outlet	ⓧ	ⓧ
Clock Outlet (Lighting Voltage)	Ⓒ	Ⓒ

CONVENIENCE OUTLETS	
Duplex Convenience Outlet	Ⓢ
Convenience Outlet other than Duplex. 1=Single, 3=Triplex, etc.	Ⓢ _{1,3}
Weatherproof Convenience Outlet	Ⓢ _{WP}
Range Outlet	Ⓢ _R
Switch and Convenience Outlet	Ⓢ _{\$}
Radio and Convenience Outlet	Ⓢ _R
Special Purpose Outlet (describe in specifications)	Ⓢ
Floor Outlet	Ⓢ

SWITCH OUTLETS	
Single Pole Switch	\$
Double Pole Switch	\$ ²
Three Way Switch	\$ ³
Four Way Switch	\$ ⁴

Automatic Door Switch	\$ ^D
Electrolier Switch	\$ ^E
Key Operated Switch	\$ ^K
Switch and Pilot Lamp	\$ ^P
Circuit Breaker	\$ ^{CB}
Weatherproof Circuit Breaker	\$ ^{WCB}
Momentary Contact Switch	\$ ^{MC}
Remote Control Switch	\$ ^{RC}
Weatherproof Switch	\$ ^{WP}

SPECIAL OUTLETS

Any standard symbol with the addition of a subscript letter designates some special variation of standard equipment.

○ a, b, c - etc.

⊙ a, b, c - etc.

List the key of symbols on each drawing and describe in specifications.

\$ a, b, c - etc.

PANELS, CIRCUITS & MISCELLANEOUS

Lighting Panel	■
Power Panel	▨
Branch 2-Wire Circuit—Ceiling or Wall	—
Branch 2-Wire Circuit—Floor	---
Indicate a greater number of wires: --- (3 wires), ---- (4 wires), etc.	
Feeders. Use heavy lines and designate by number from Feeder Schedule	—
Underfloor Duct & Junction Box—Triple System. For double or single systems eliminate one or two lines	≡
Generator	Ⓖ
Motor	Ⓜ
Instrument	Ⓘ
Transformer	Ⓙ

Controller	⊠
Isolating Switch	⊠

AUXILIARY SYSTEMS

Push Button	⊙
Buzzer	⊠
Bell	⊠
Annunciator	◇
Telephone	⊠
Telephone Switchboard	⊠
Clock (Low Voltage)	⊠
Electric Door Opener	Ⓓ
Fire Alarm Bell	Ⓕ
Fire Alarm Station	Ⓕ
City Fire Alarm Station	⊠
Fire Alarm Central Station	Ⓕ
Automatic Fire Alarm Device	Ⓕ
Watchman's Station	Ⓕ
Watchman's Central Station	Ⓕ
Horn	Ⓕ
Nurse's Signal Plug	Ⓕ
Maid's Signal Plug	Ⓕ
Radio Outlet	Ⓕ
Signal Central Station	Ⓕ
Interconnection Box	⊠
Battery	
Auxiliary System 2-Wire Circuit	---

For a greater number of wires designate with numerals—12-No. 18W- $\frac{3}{4}$ "-C., or by listing in schedule.

ELECTRIC SWITCHES & THEIR USES

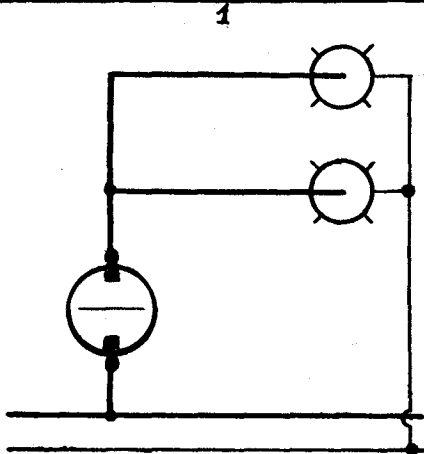

A single-pole switch used to control two lights in parallel.

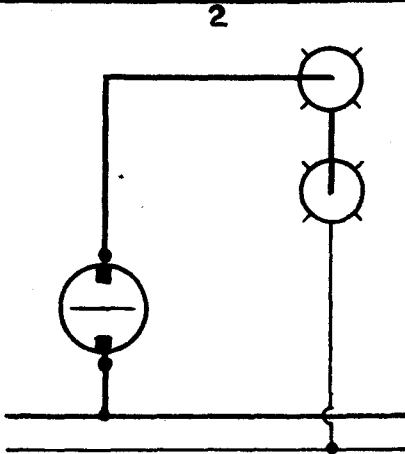

A single-pole switch used to control two lights in series.

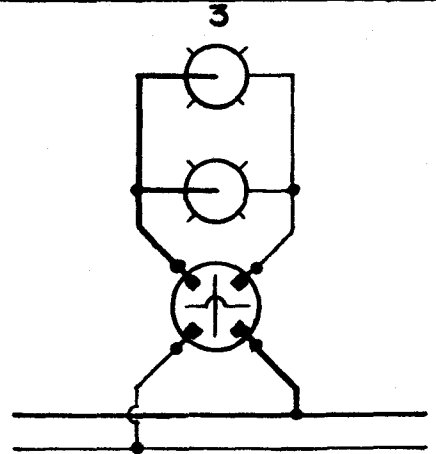

A double-pole switch used to control two lights in parallel.

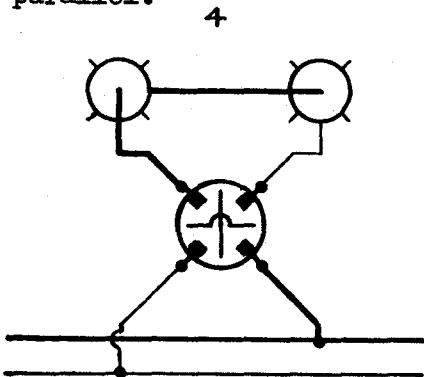

A double-pole switch used to control two lights in series.

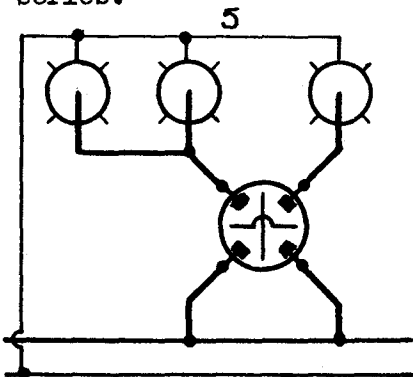

A double-pole switch used to take the place of two single-pole switches giving control to two distinct circuits.

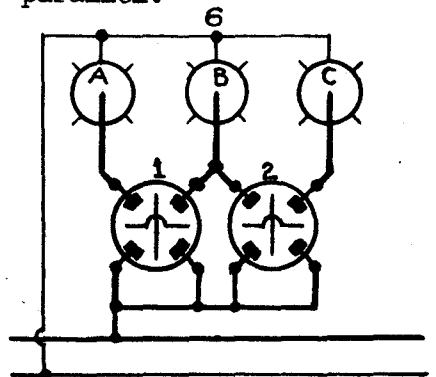

A selective control provided by 2 double-pole switches. Lights A and B are controlled by switch #1; lights B and C are controlled by switch #2.

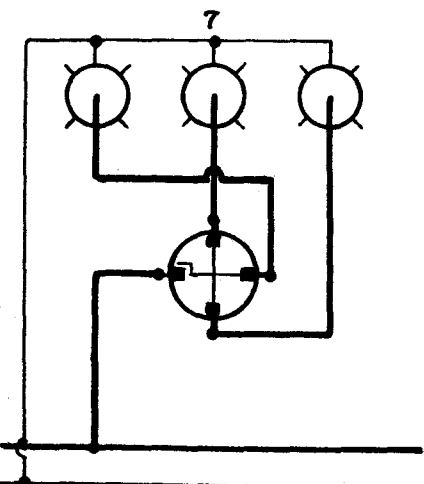

Electrolier switch used to control three separate lights from one place.

1st position lamp #1 on
 2nd " " #2 "
 3rd " " #3 "
 4th " all off.

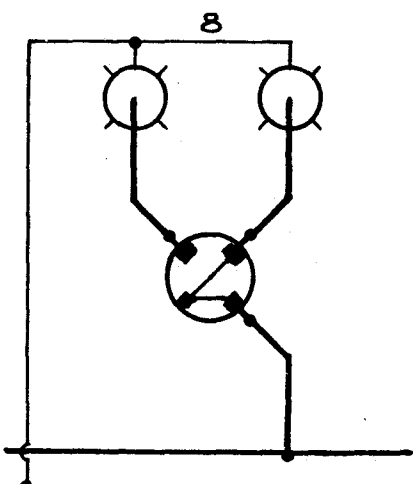

A 3-way switch used to control 2 lights alternately. One or the other will be lighted.

1st position lamp #1 on.
 2nd " " #1 and #2 on.
 3rd " " #1, #2 and #3 on.
 4th " " all off.

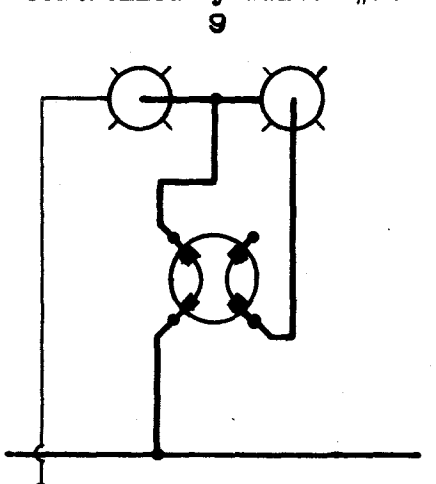

A 4-way switch used to control one light only, or 2 lights in series.

ELECTRIC SWITCHES & THEIR USES

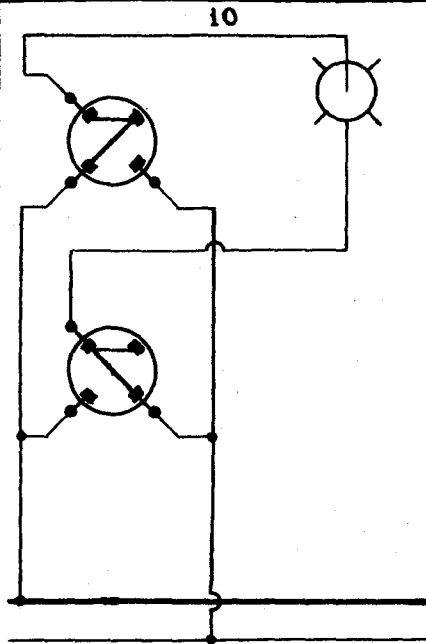

This is the "Carthwaise" method used to control lights from 2 places, using two 3-way switches. This system is not approved by the Code for 110E systems, but may be used on 32E systems.

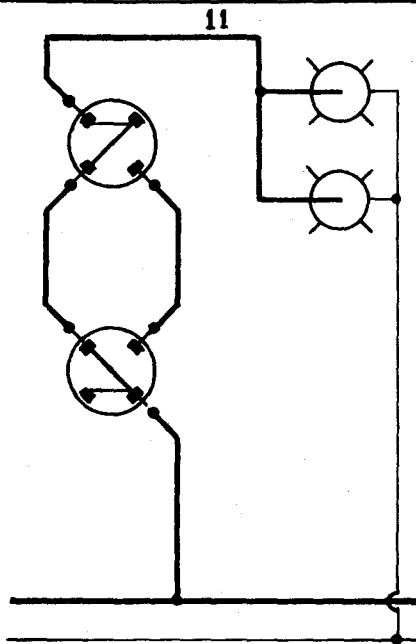

This circuit is the "Standard" method for two-place control using two 3-way switches and is approved by the Code for 110E.

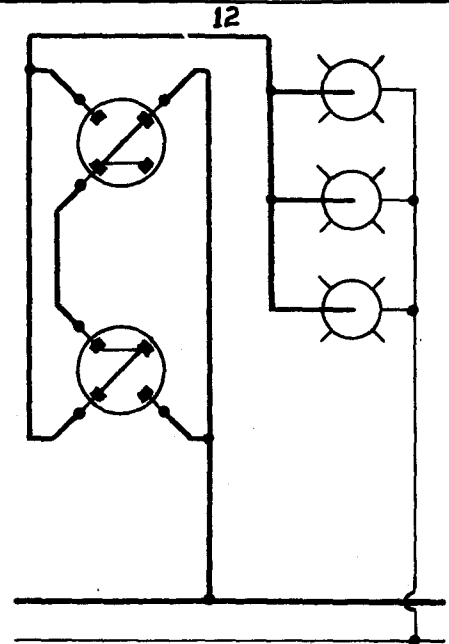

This shows another method of controlling lights from 2 places.

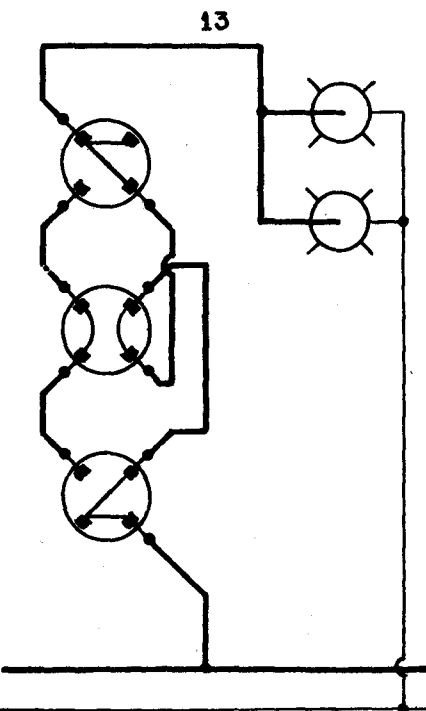

Method used to control one or more lights from three places.

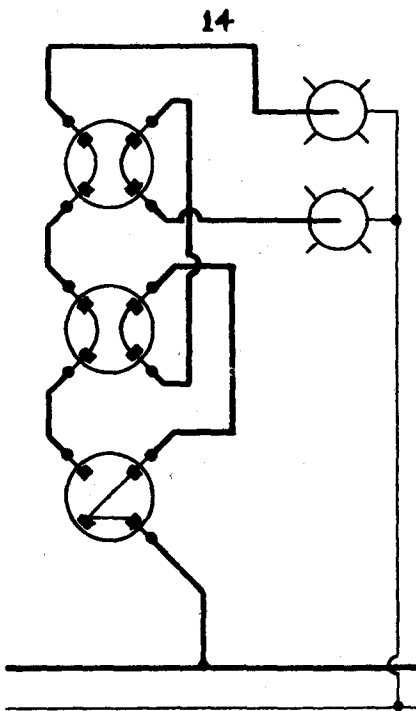

This diagram shows how to control each light alternately from three different places.

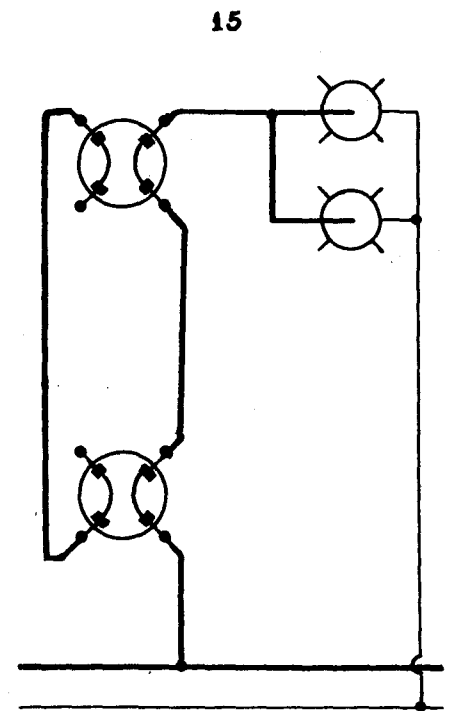

Possible circuit used to control two lights in parallel from two places using two 4-way switches.

ELECTRIC SWITCHES & THEIR USES

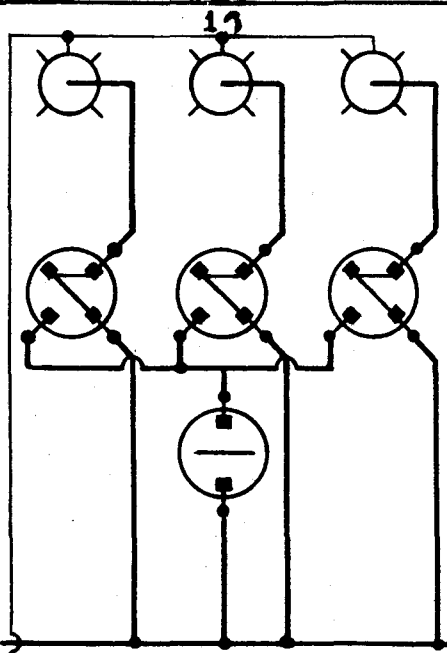

This shows 3 lights, each one individually controlled from one place, using a three-way switch as a single-pole switch. The one single-pole switch is used as a master switch when the master switch is on; the other lights cannot be turned off.

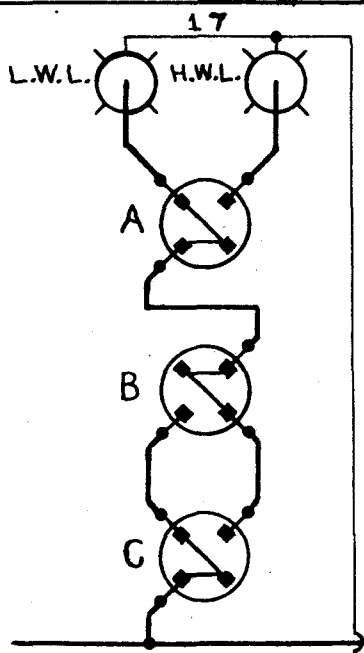

An additional 3-way switch used when it is desired to use a low wattage lamp part of the time. Switches B and C will control the circuit and switch A will select either the high or low wattage lamp.

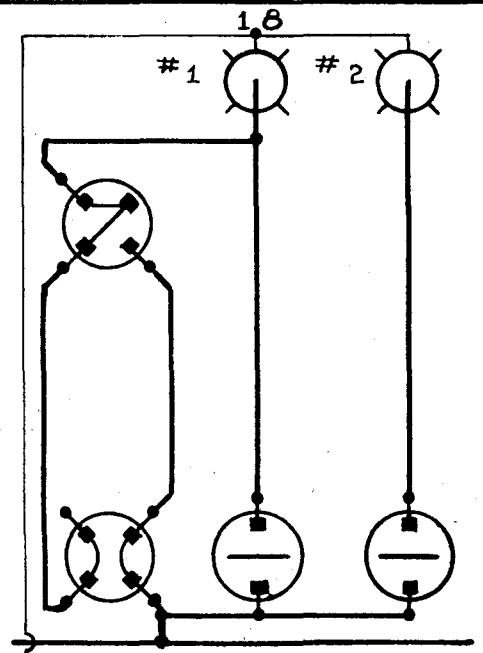

A 3-way switch and a 4-way switch used to control lamp #1 with a single-pole switch as a master switch. Lamp #2 has separate control.

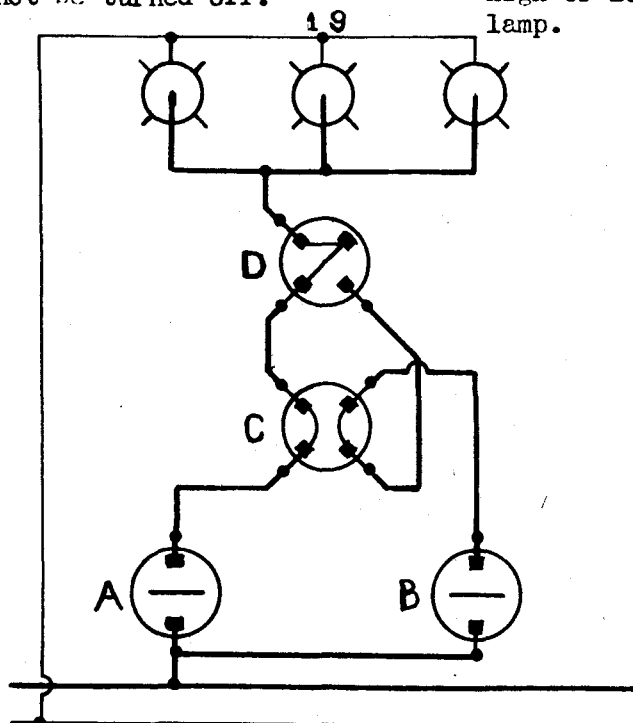

By means of 2 single-pole switches at A and B, it is possible to prevent turning the lights on or off at switches C and D. When switches A and B are closed, the lamps cannot be turned off. When switch A is on and B is off, the lamps may be controlled from switches C and D.

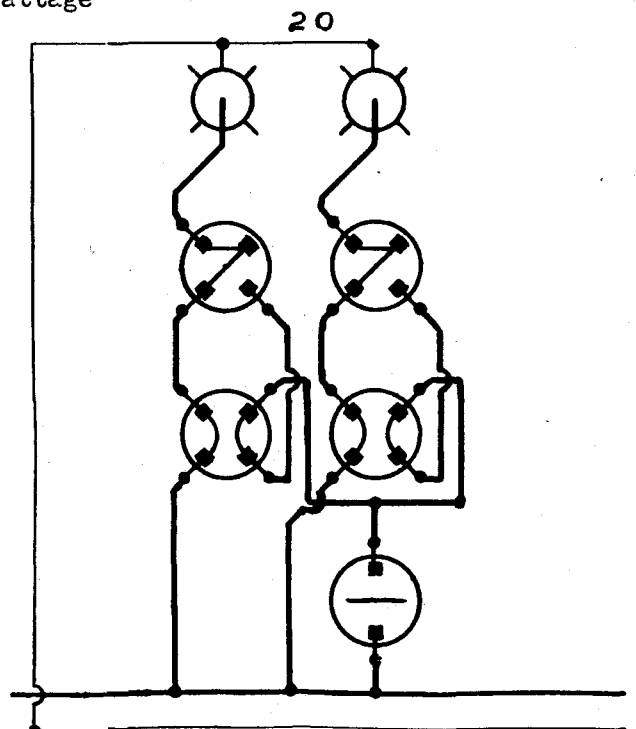

When the single-pole switch is open, each of the 2 lights may be controlled from 2 places. When the single-pole switch is closed, all the lamps will remain lighted regardless of the position of the other switches.

SPECIFICATIONS FOR WIRING OF BUNGALOW

GENERAL CONDITIONS

The standard form of "General Conditions of Contract" of the American Institute of Architects, copies of which are on file with the Owner, shall govern and is hereby considered and acknowledged a part of the specifications covering this work.

PROGRESS OF INSTALLATION

The Electrical Contractor shall keep himself informed of the progress of the general construction of the building so that he may begin his work at the earliest opportunity in order to avoid delaying the progress of the work as a whole. He shall provide a working crew of adequate numbers to install the work as rapidly as may be consistent with the class of work required. He shall cooperate with all other contractors on the job to serve the best interests of the owner.

CODE RULES

All material and work shall conform in all respects to the latest rules and requirements of the National Electric Code and the Public Service Company requirements.

BIDS

This bid shall be based on armored cable (B.X.) with conduit used only from point of entrance to the service switch.

SERVICE

The Electric Company shall bring the main wires to the weatherhead and connect them to the service wires which shall be installed by the contractor. The contractor shall furnish an approved type service switch and wire for the meter. The meter to be furnished and installed by the Public Service Company.

MATERIALS

All materials shall be new, and shall bear the Underwriter's label. Outlet boxes for walls and ceiling lights shall be fitted with a fixture stud. Wall switches shall be of the toggle type and shall be either single pole or three-way to suit the plan requirements. Whenever two or three switches are adjacent to one another they shall be arranged for gang or tandem cover plates. Wall or base outlets shall be of the double or duplex flush type.

FIXTURES

Fixtures and hanging of same will be done under separate contract.

SERVICE

(Conduit)

SUMMARY

	unit cost	2 cir. 2 wire		4 cir. 3 wire	
		quantity	cost	quantity	cost
1/2" conduit		15'		15'	
3/4" conduit		20'			
1" conduit				20'	
#8 wire		45		65'	
Ground wire		20'		20'	
2w. Service sw.		1			
3w. Service sw.				1	
* 3/4" Service head		1		1	
* 3/4" LB Fitting		1		1	
Ground clamp		1		1	
Fuse plugs		3			
Fuse plugs				6	
Miscellaneous					
Labor-hours		7		9	
Total					

quantity	Items	unit cost	total
	ceil/wall outlet		
	convenience out.		
	S. P. switch		
	3 way switch		
	Service		
	Permit		
	Total		

%	total
65 Labor and material	
25 Overhead	
10 Profit	
100% Total	

* For a 3 wire service these items should be 1"

CONTRACT

Estimate number	Date
<p>I (We) hereby propose to furnish labor and material necessary to install the wiring system in and about the premises located at _____ for the sum of _____ Dollars.</p> <p>Payment shall consist of 80% of the total when the work is roughed in, the balance to be paid after final inspection.</p> <p>The work done and the material furnished under this proposal shall comply with all local requirements governing this class of work and in accord with the latest rules and requirements of the National Electric Code.</p> <p>The work done and the materials furnished under this proposal shall comply with the specifications and drawings submitted.</p> <p>All changes shall be made in writing and signed by both parties hereto, which said writings shall set out and contain in full the character, extent, cost and conditions of said change.</p>	
Accepted	Contractor
Owner	Date

Circuits and Wiring

WIRING

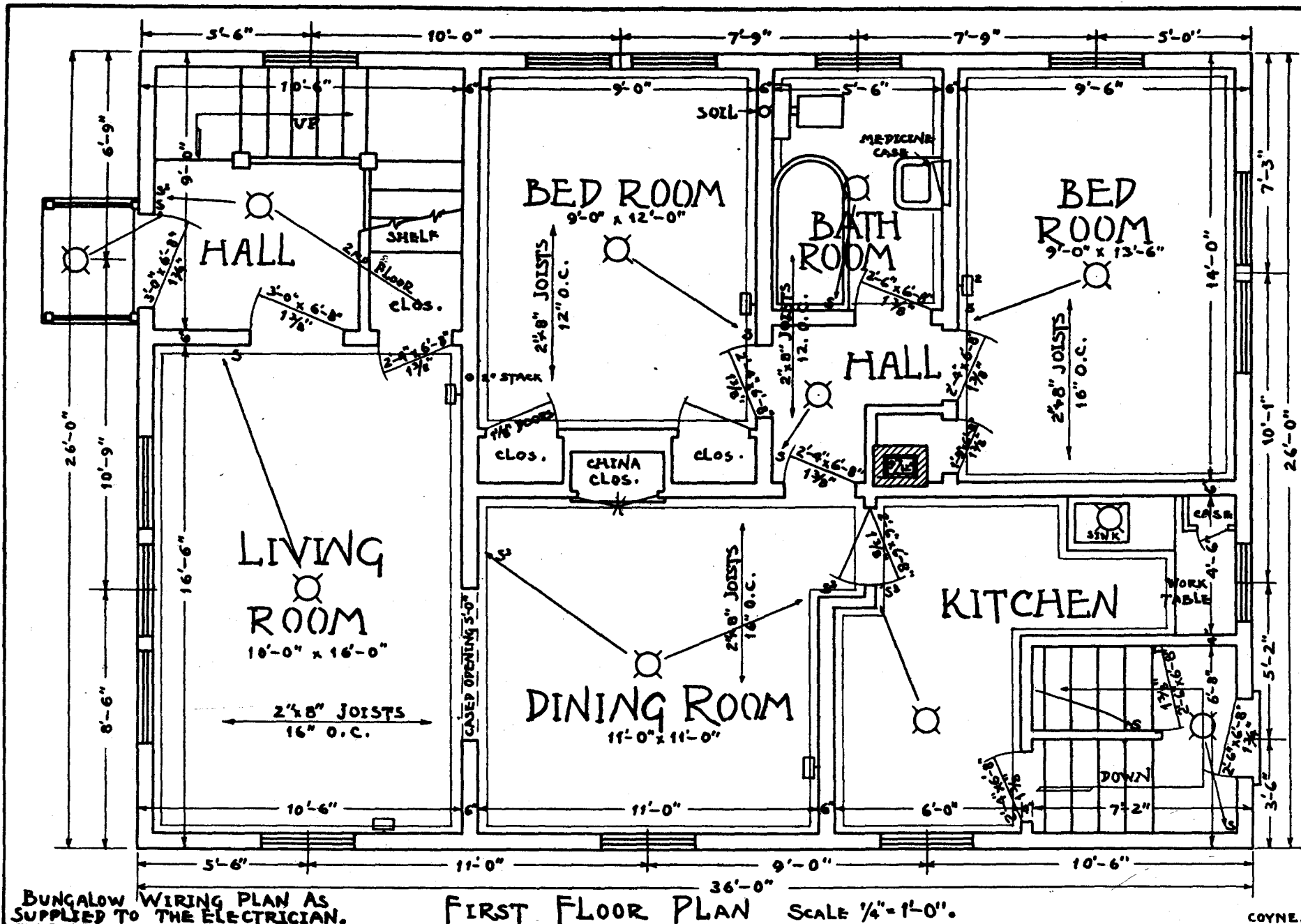

Circuits and Wiring

STANDARDS OF ILLUMINATION FOR STORES, COMMERCIAL AND PUBLIC INTERIORS

Recommended by Nela Park Laboratories

(These foot-candle values represent order of magnitude rather than exact levels of illumination)

Foot-Candles	Foot-Candles	Foot-Candles	Foot-Candles
Armories — Drill Sheds and Exhibition Halls..... 10	Hospitals:	Office Buildings, (continued)	Service Space, continued:
Art Galleries:	Corridors..... 2	Drafting—	Elevators—Freight and Passenger..... 10
General..... 5	Laboratories..... 20	Prolonged Close Work—	Halls and Stairways..... 5
On Paintings..... B*	Lobby & Reception Room..... 5	Art Drafting and Designing in Detail..... C*	Storage..... 5
Auditoriums..... 5	Operating Room	Rough Drawing and Sketching..... 30	Toilets and Wash Rooms..... 5
Automobile Show Rooms..... 20	General..... 20	Filing and Index References..... 20	Show Cases..... B*
Banks:	Operating Table	Lobby..... 10	Show Windows:
Lobby..... 15	Major Operations..... 1000	Mail Sorting..... 20	Large Cities—
Cages..... B*	Minor Operations..... 200	Reception Rooms..... 10	Brightly Lighted Districts..... 200
Offices..... 20	Private Rooms (with local illumination)..... 20	Stenographic Work—	Secondary Business Locations..... 100
Barber Shops and Beauty Parlors..... 20	Wards (with local illumination)..... 20	Prolonged Reading Short-hand Notes..... C*	Neighborhood Stores..... 50
Churches:	Hotels:	Vault..... 10	Medium Cities—
Auditoriums..... 5	Lobby..... 10	Post Office:	Brightly Lighted District..... 100
Sunday School Rooms..... 10	Dining Room..... 5	Lobby..... 10	Neighborhood Stores..... 50
Pulpit or Rostrum..... 20	Kitchen..... 20	Sorting, Mailing, etc..... 20	Small Cities and Towns..... 50
Club and Lodge Rooms:	Guest Rooms..... 10	Storage..... 10	Lighting to Reduce Daylight Window Reflections..... 200-1000
Lounge and Reading Rooms..... 20	Corridors..... 2	Offices—Private & General..... 20	Special Displays Inside Store:
Auditoriums..... 5	Writing Rooms..... 20	File Room and Vault..... 10	Light Colored..... C*
Court Rooms..... 10	Library:	Corridors and Stairways..... 2	Medium Colored..... B*
Dance Halls..... 5	Reading Room..... 20	Professional Offices:	Dark Colored..... A*
Depots:	Stack Room..... 10	Waiting Rooms..... 10	Stores:
Waiting Rooms..... 10	Moving Picture Theatre:	Consultation Rooms..... 20	Large Cities—
Ticket Offices—	During Intermission..... 5	General Offices..... 20	Brightly Lighted Districts..... 20
General..... 10	During Pictures..... 0.1	Dental Chairs and Doctors' Examination Rooms..... A*	Secondary Business Locations..... 20
Ticket Rack and Counters..... B*	Museums:	Restaurants, Lunch Rooms and Cafeterias:	Neighborhood Stores..... 15
Rest Rooms, Smoking Rooms..... 10	General..... 10	Dining Areas..... 10	Medium Cities—
Baggage Checking Office..... 10	Special Displays..... B*	Food Displays..... C*	Brightly Lighted Districts..... 20
Storage..... 5	Night Clubs and Bars..... 5	Schools:	Neighborhood Stores..... 15
Concourse..... 5	Office Buildings:	Auditoriums and Lecture Rooms—	Small Cities and Towns..... 15
Platforms..... 2	Bookkeeping, Typing and Accounting..... 30	General..... 10	Telephone Exchanges:
Drafting Rooms:	Business Machines—Power Driven (Transcribing & Tabulating)..... B*	Special Exhibits..... C*	Operating Rooms..... 5
Prolonged Close Work, Art in Detail..... C*	Calculators, Key Punch, Bookkeeping..... B*	Class and Study Rooms—	Terminal Rooms..... 15
Drafting and Designing	Conference Rooms..... 10	Desks & Blackboards..... 5	Cable Vaults..... 5
Rough Drawing and Sketching..... 30	General Meetings..... 10	Corridors and Stairways..... 5	Theatres:
Fire Engine Houses:	Office Activities—See Desk Work..... 5	Drawing Room..... C*	Auditoriums..... 5
When alarm is turned in..... 10	Corridors and Stairways..... 5	Gymnasium..... C*	Foyer..... 10
At other times..... 2	Desk Work—	Laboratories—	Lobby..... 15
Garages—Automobile:	Desk Work..... 5	General..... 10	Transportation:
Storage—Dead..... 2	Intermittent Reading and Writing..... 20	Close Work..... C*	Cars—
Live..... 5	Prolonged Close Work, Computing, Studying, Designing, etc..... C*	Library and Offices..... 20	Baggage, Day Coach, Dining, Pullman..... 15
Repair and Washing Departments..... C*	Reading Blueprints and Plans..... 30	Manual Training—	Mail—
Hangars—Acroplane:		General..... 20	Bag Racks and Letter Cases..... 20
Storage—Live..... 10		Close Work..... B*	Storage..... 5
Repair Department..... C*		Sewing Room..... B*	Street Railway, Trolley Bus and Subway..... 15
		Sight-Saving Classes..... C*	Motor Bus..... 10
		Service Space:	
		Corridors..... 5	

**In these areas many of the machines require one or more supplementary lighting units mounted on them in order to effectively direct light toward the working points.

*Lighting recommendations for the more difficult seeing tasks, as indicated by A, B, and C in the foregoing table, are as follows:

GROUP A — These seeing tasks involve (a) the discrimination of extremely fine detail under conditions of (b) extremely poor contrast, (c) for long periods of time. To meet these requirements, illumination levels above 100 foot-candles are recommended.

To provide illumination of this order a combination of at least 20 foot-candles of general lighting plus specialized supplementary lighting is necessary. The design and installation of the combination systems must not only provide a sufficient amount of light but also must provide the proper direction of light, diffusion, eye protection and, insofar as possible, must eliminate direct and reflected glare as well as objectionable shadows.

GROUP B — This group of visual tasks involves (a) the discrimination of fine detail under conditions of (b) a fair degree of contrast (c) for long periods of time. Illumination levels from 50 to 100 foot-candles are required.

To provide illumination of this order a combination of 10 to 20 foot-candles of general lighting plus specialized supplementary lighting is necessary. The design and installation of the combination systems must not only provide a sufficient amount of light but also must provide the proper direction of light, diffusion, eye protection and, insofar as possible, must eliminate direct and reflected glare as well as objectionable shadows.

GROUP C — The seeing tasks in this group involve (a) the discrimination of moderately fine detail under conditions of (b) better than average contrast (c) for intermittent periods of time. The level of illumination required is of the order of 30 to 50 foot-candles and in some instances it may be provided from a general lighting system. Oftentimes, however, it will be found more economical and yet equally satisfactory to provide from 10 to 20 foot-candles from the general system and the remainder from specialized supplementary lighting. The design and installation of the combination systems must not only provide a sufficient amount of light but also must provide the proper direction of light, diffusion, eye protection and, insofar as possible, must eliminate direct and reflected glare as well as objectionable shadows.

Standards For Indoor Recreational Lighting

Foot-Candles	Foot-Candles	Foot-Candles	Foot-Candles
Billiards:	Boxing, continued:	Gymnasium, continued:	Other Sports:
General..... 10	Ring: Amateur..... 100	Fencing, Boxing, Wrestling..... 20	Badminton, Handball, Racquet, Squash..... 30
On Tables..... 50	Professional..... 200	Basket Ball..... 20	Basket Ball, Volley Ball..... 20
Bowling:	Championship..... 500	Soft Ball..... 30	
General..... 10	Gymnasium:	Skating Rink..... 10	
On Pins..... 50	Exercising Room..... 15	Table Tennis—Ping Pong..... 30	
Boxing:	Shower Rooms..... 10	Tennis: Recreational..... 20	
Seats..... 2	Locker Rooms..... 5	Tournament..... 30	

CIRCUIT WIRING DIAGRAM OF BUNGALOW WIRING SYSTEM.

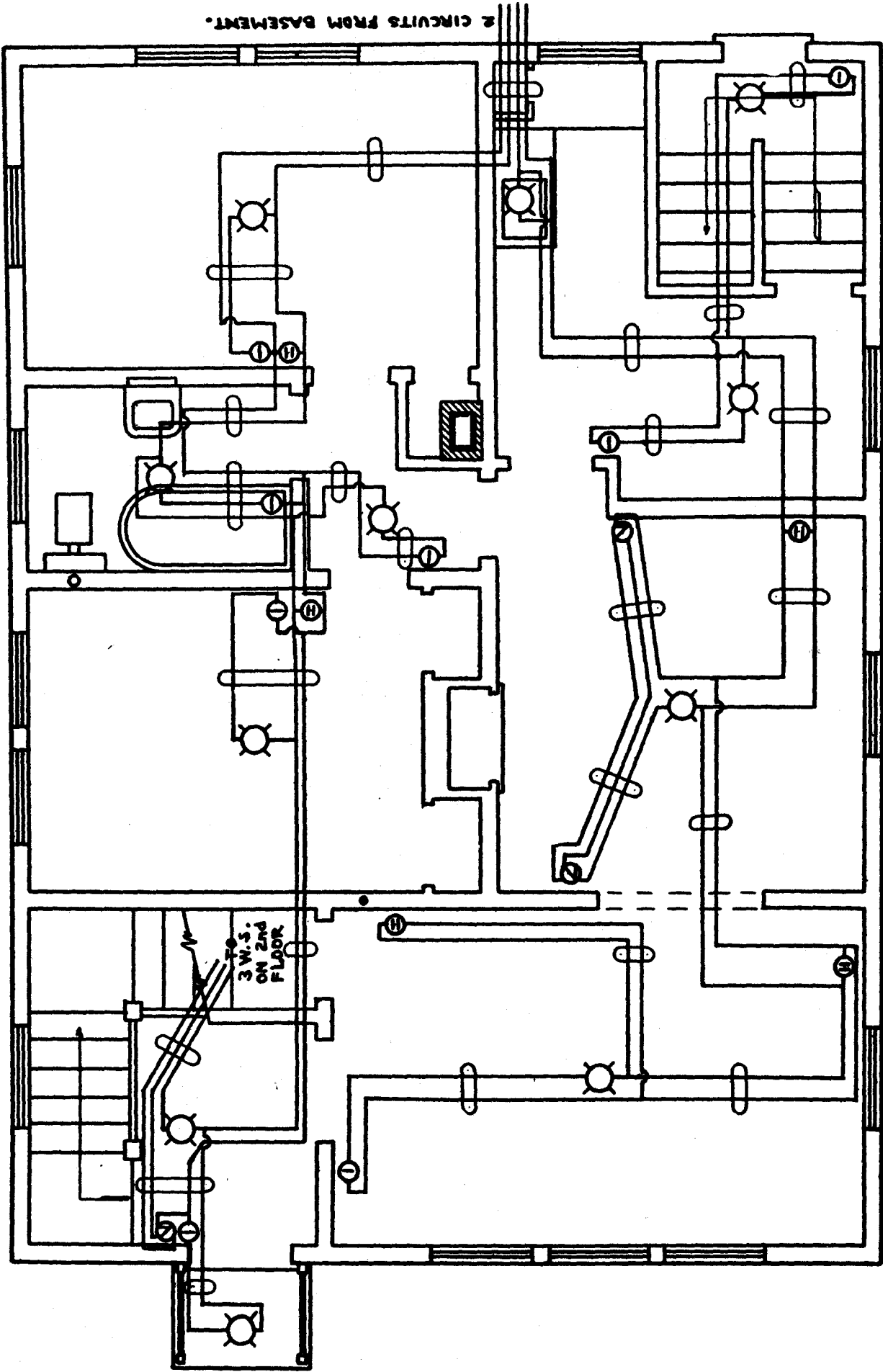

ELECTRIC RANGE CIRCUITS AND INSTALLATION

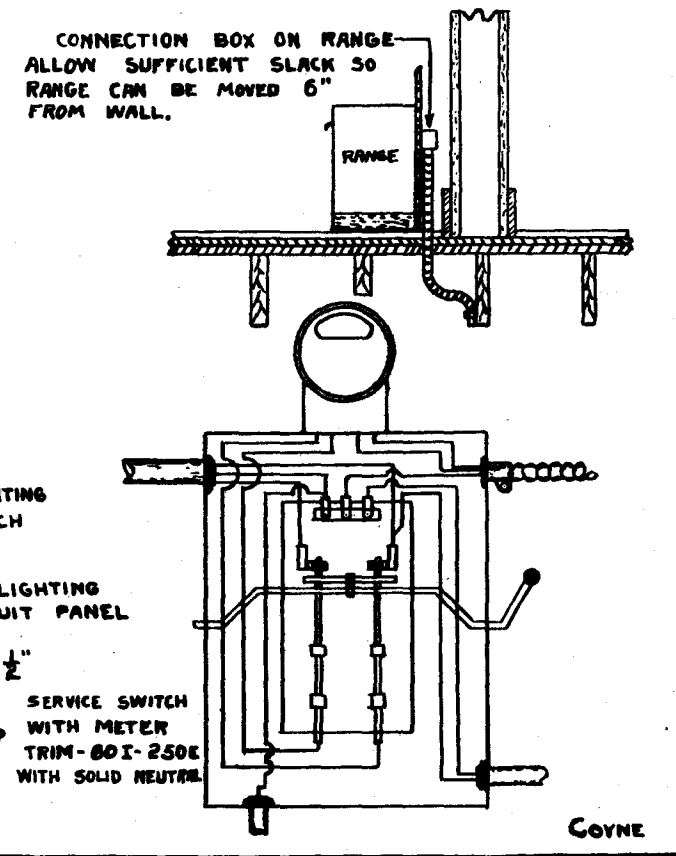
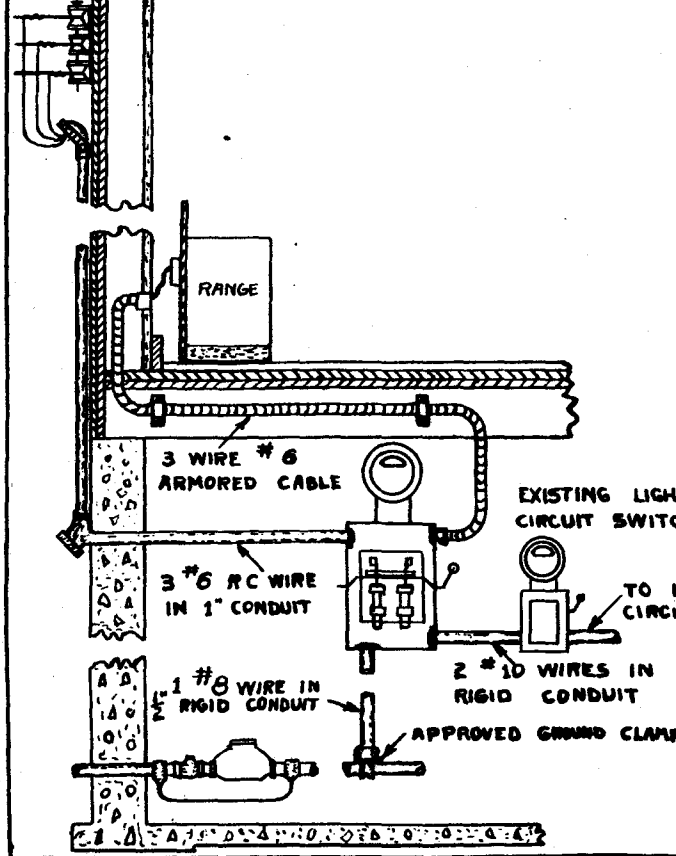
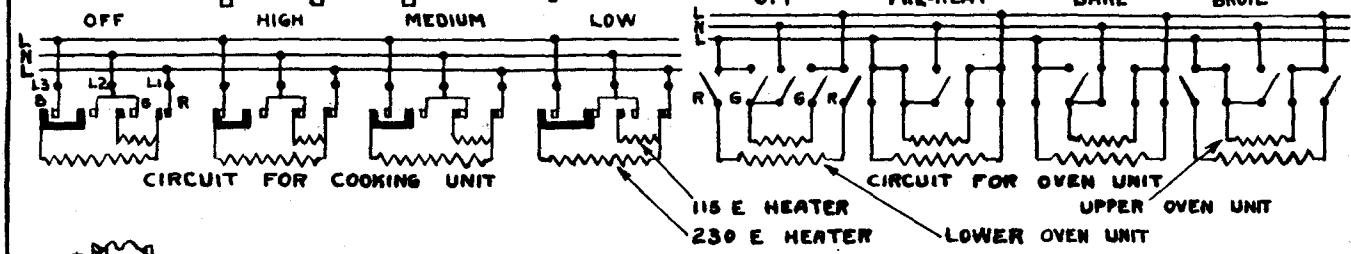
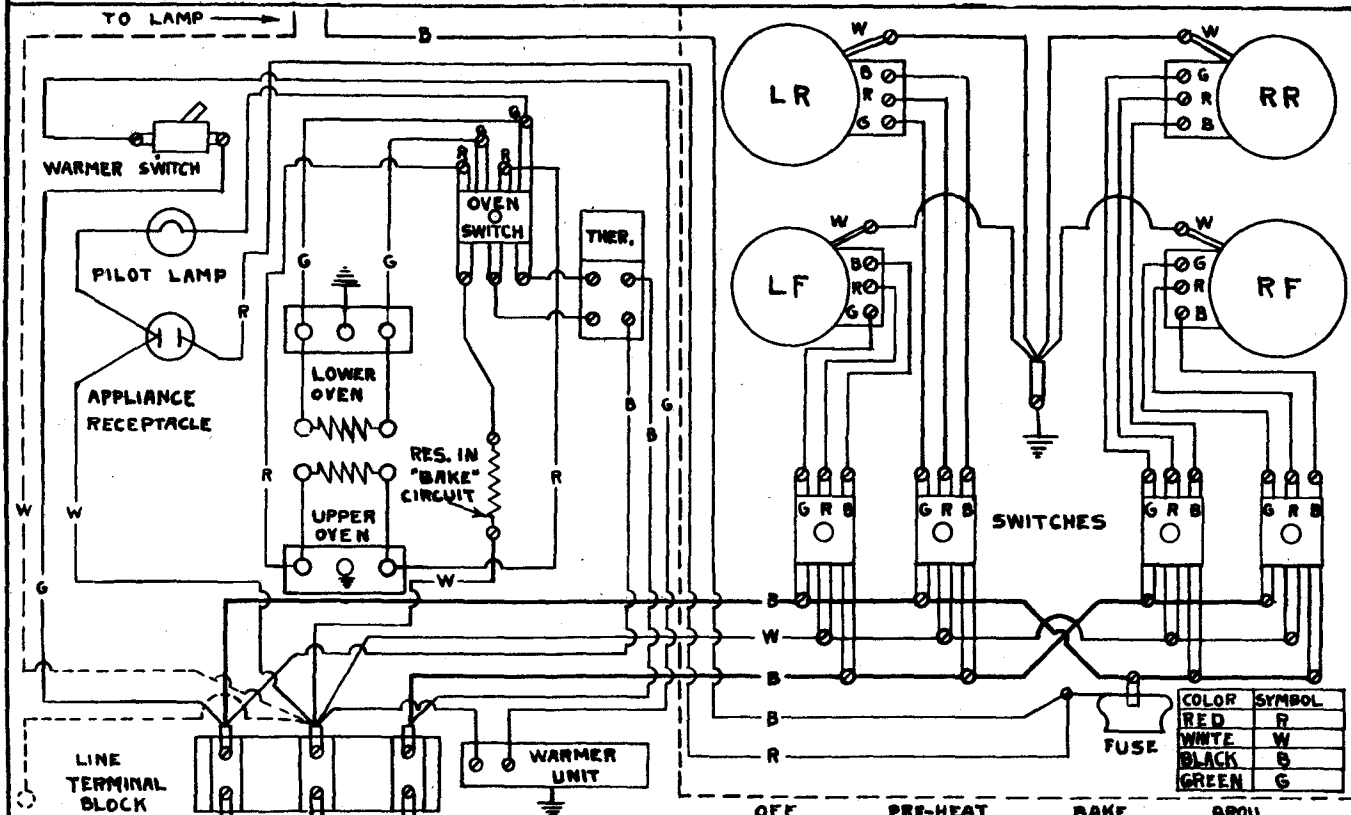

METER CONNECTIONS

2-WIRE SINGLE FUSED SWITCH,
TWO 2-WIRE SINGLE FUSED BRANCH CIRCUITS.

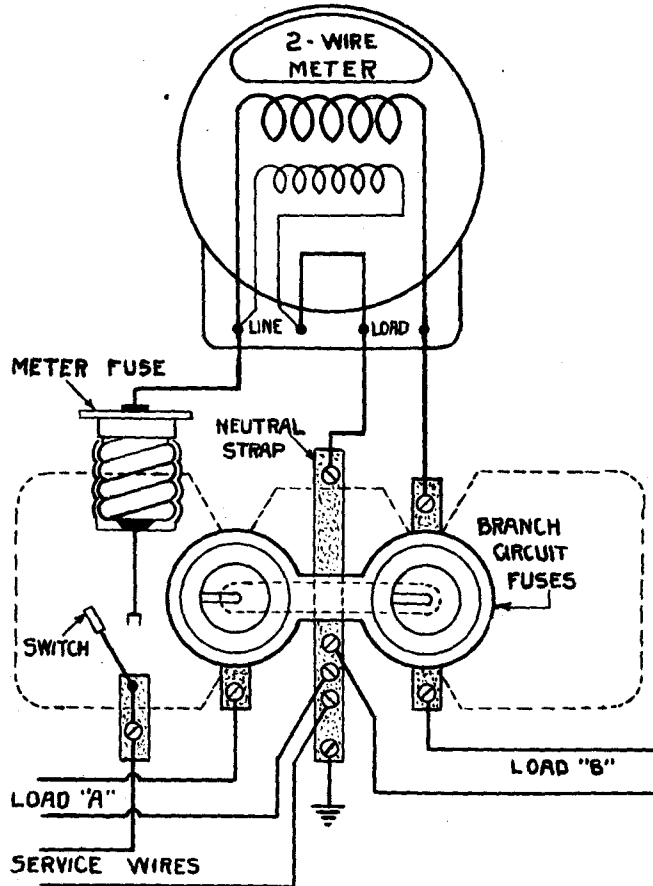

3-WIRE SOLID NEUTRAL SWITCH,
ONE 3-WIRE 2-FUSED BRANCH CIRCUIT.

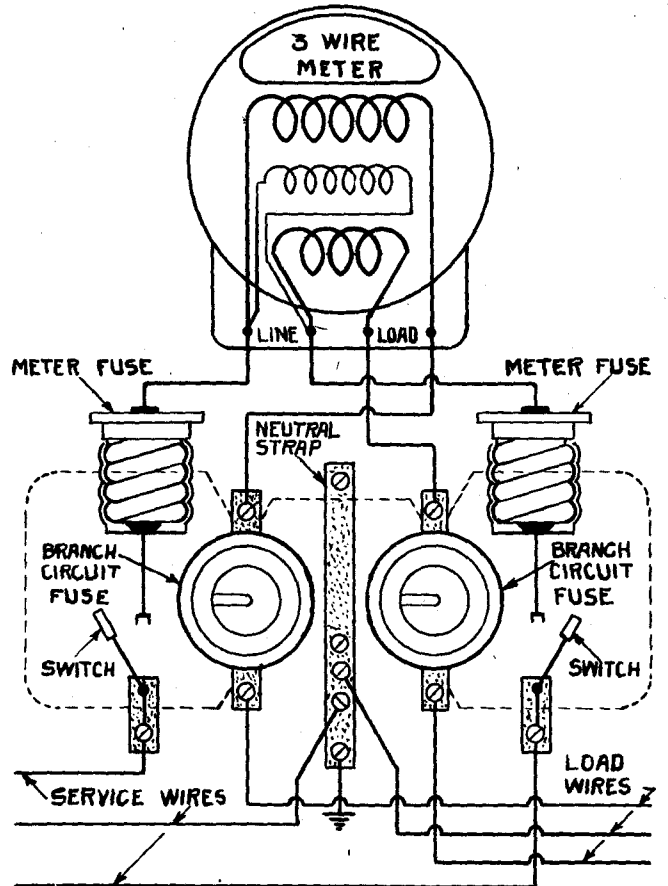

3-WIRE SOLID NEUTRAL SWITCH,
FOUR 2-WIRE SINGLE FUSED BRANCH CIRCUITS.

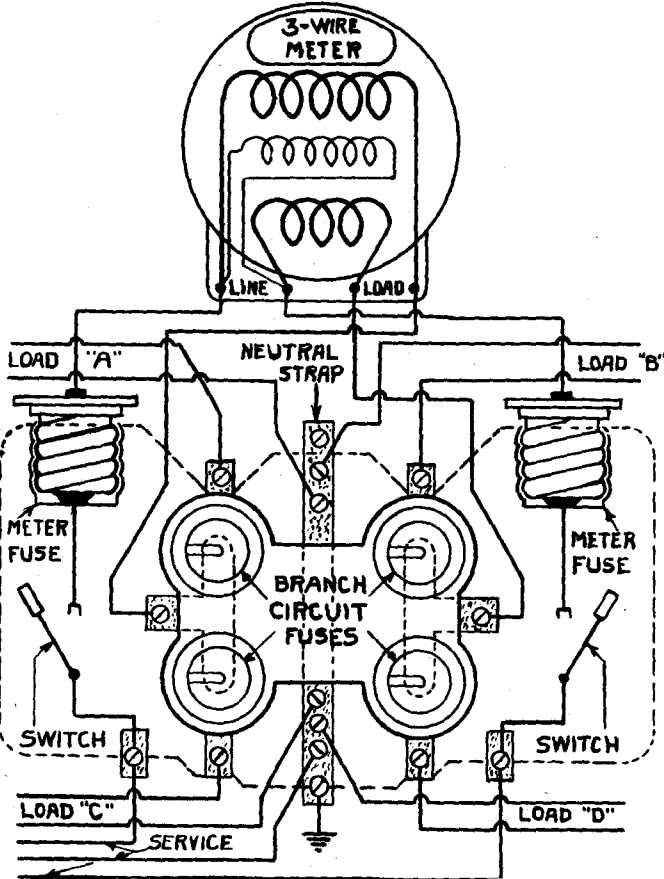

3 PHASE METER

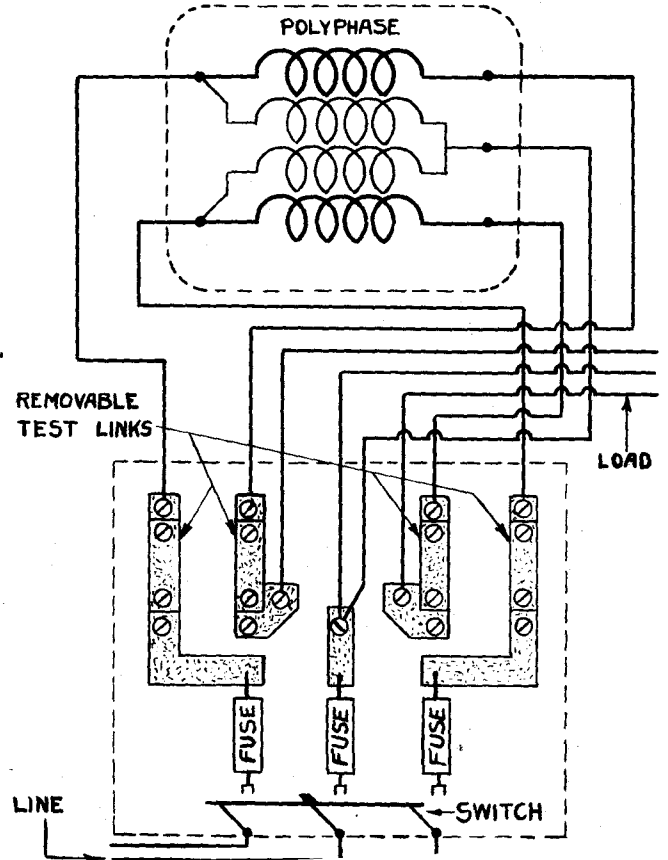

WIRING METER BASE FOR SOCKET TYPE METER

3-WIRE

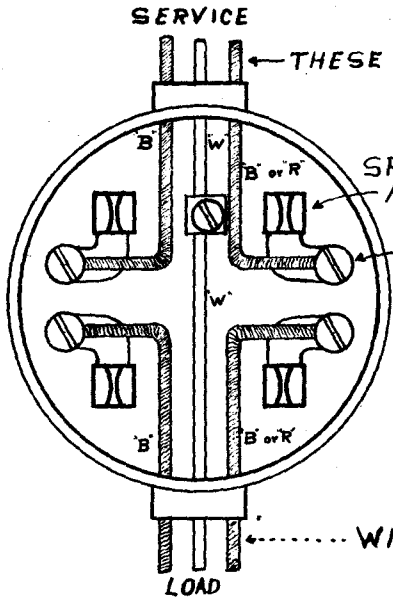

2-WIRE

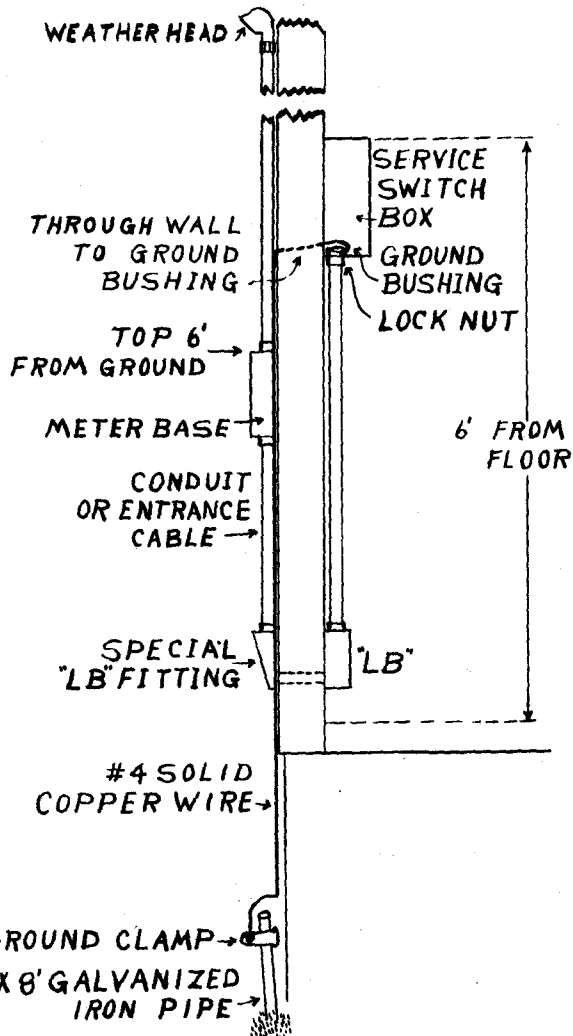
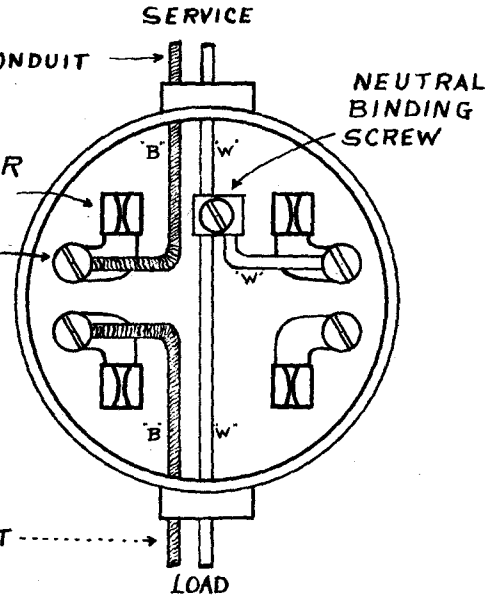

CONNECTIONS IN SERVICE BOX

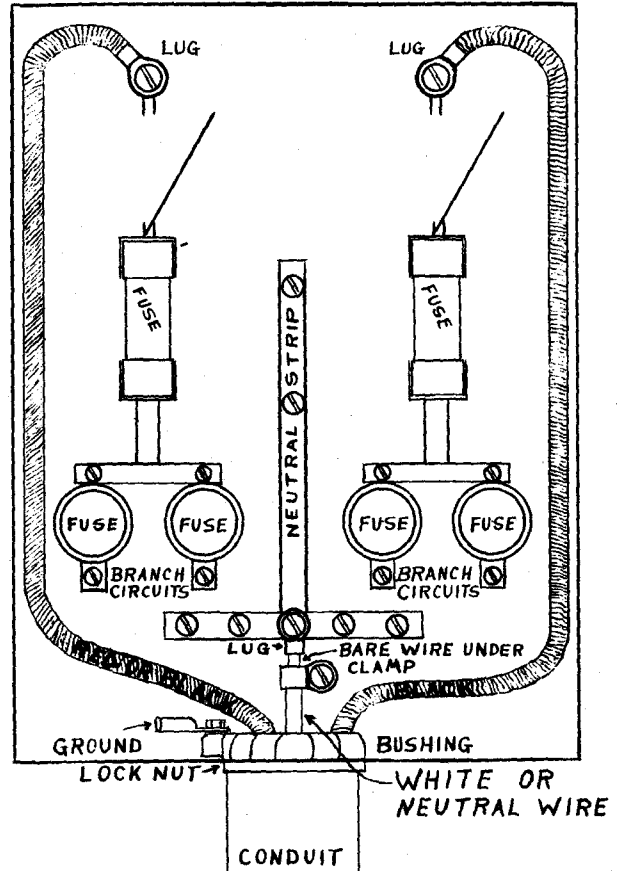

HIGH VOLTAGE TEST SET FOR WIRING INSTALLATIONS R.E.A. RECOMMENDATIONS

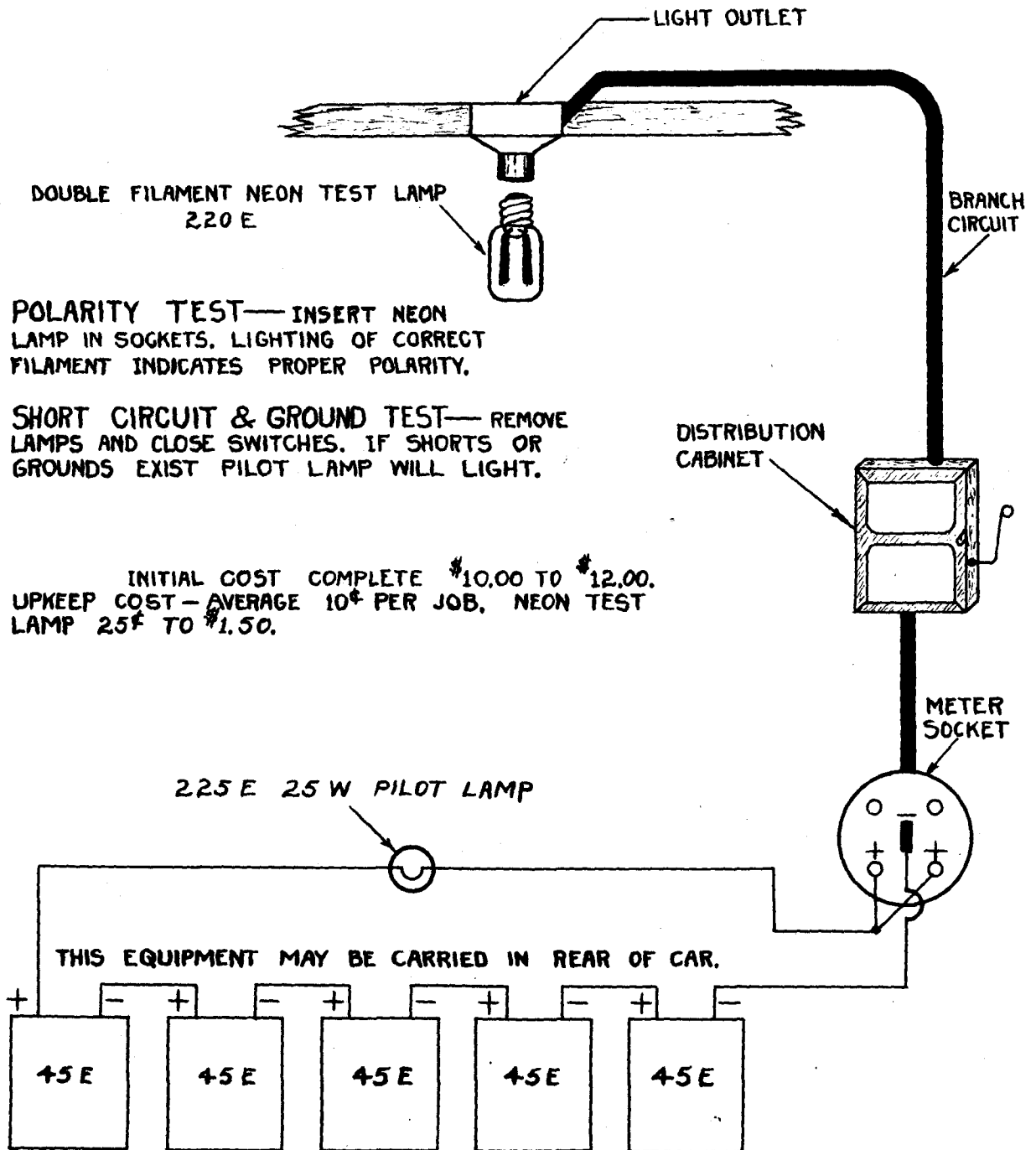

SUPPLY FOR TESTING — FIVE 45 E HOT-SHOT BATTERIES

ANY D.C. SUPPLY OF 220 E MAY BE USED, SUCH AS THE POWER PACK USED IN AUTO RADIO. THEN THE CAR BATTERY COULD BE USED AS A SOURCE. MALLORY VIBRAPACK #V.P. 552 MAY BE USED IN CONJUNCTION WITH A CAR BATTERY. THIS VIBRATOR POWER PACK HAS AN OUTPUT OF 225 VOLTS AND UP, AND 100 M.A. CAPACITY. MAY BE PURCHASED FOR \$11.00.

TECHNICAL TERMS AND THEIR MEANING

A clear understanding of Electricity can be acquired only if the terms employed to explain it and the units used to measure it are clearly understood. Words used in the technical sense have exact meanings frequently different from those associated with their every day use. Definitions here given refer to the technical meanings only. Some of the most important terms and their units of measurement are:

FORCE - Force is defined as "any agent that produces or tends to produce motion." Force may be mechanical, electrical, magnetic, or thermal in character. Note that force does not always produce motion: a relatively small force may fail to move a large body, but it **TENDS** to do so. The word "body" refers to any material object: it may be a stone, a building, an automobile, a dust particle, an electron, or anything that has size. Force is usually measured in pounds; therefore the **UNIT** of **FORCE** is the **POUND**.

ENERGY - This word refers to the ability or capacity for doing work. One may speak correctly of the **ENERGY** in a charged automobile battery, in a raised weight, in a compressed spring, in a tank of compressed air, etc., as work may be done by any one of these devices. Energy may be mechanical, electrical, magnetic, chemical, or thermal type, and the different kinds of energy may be readily converted from one form to another; however, each conversion results in a loss of some of the useful energy, although the total amount of energy remains the same. Since the energy of a device represents the total amount of work that it can do, the units for work and for energy are the same. The **UNIT OF ENERGY** most frequently used in electrical work is the **JOULE**. It is equal to approximately 0.74 foot pounds.

WORK - Work is equal to the force applied to an object multiplied by the distance through which the object is moved. If the force applied to a given object is insufficient to move it, no work is done. This definition illustrates the great difference that exists between the technical and the general meaning of the word **WORK**. The units used for measuring work are the same as those employed for energy. The most frequently used **UNITS OF WORK** are the **FOOT POUND** and **JOULE**.

POWER - Power indicates the rate at which work is done. It is equal to the amount of work done, divided by the time required to do it. This unit does not show how much work has been done, it merely indicates how rapidly, or at what rate, the work is being done. The fundamental **UNIT** of electrical **POWER** is the **WATT**. When the power in an electrical circuit is one watt, this means that work is being done in that circuit at the rate of one joule per second, or 0.74 foot pounds per second. Note that the **WATT** is not a quantity unit but a **RATE** unit. Larger power units are the horse-power and the kilowatt. The **HORSEPOWER** represents a rate of doing work equal to 746 **WATTS**, or 746 joules per second, or 550 foot pounds per second. Note that **TIME**, which is not mentioned in the definitions of force or energy, is always a factor in the measurement of **POWER**.

$$(a) \quad \text{POWER} = \frac{\text{WORK}}{\text{TIME}}$$

$$(b) \quad \text{WORK} = \text{POWER} \times \text{TIME}$$

$$(c) \quad \text{TIME} = \frac{\text{WORK}}{\text{POWER}}$$

With the aid of the above formulas any of the given quantities may be calculated when the other two are given. Thus if work and time are given, the power may be found by (a). If power and time are given, the work may be found by formula (b), and if the work to be done and the rate at which it is to be done (power) are specified, the time required to do it may be determined by formula (c).

A little time spent in studying the above definitions and formulas will be well repaid by an increased understanding and clearer conception of the units used.

1. The only technically correct definition of force is: (A) that agent which produces motion (B) that which indicates a group acting together, such as a police force (C) that agent which produces or tends to produce motion (D) that agent which overcomes opposition, as when one force overcomes another.
2. The only technically correct definition for the term energy is: (A) the rate at which work can be done (B) the total work done in a given time (C) the ability or capacity of some agent to do work (D) the rate at which work is done.
3. The technically correct definition for power is: (A) the force required to overcome opposition (B) the rate at which work is done (C) the total work done (D) the rate at which force is applied to an object.
4. Work is always done: (A) when force is applied to an object (B) when the applied force produces motion or a change in motion (C) when one force opposes another.
5. Of the four units given here the only one that measures force is the: (A) Watt (B) Pound (C) Joule (D) Foot-pound.
6. The unit of energy most frequently used in electrical work is the: (A) Watt (B) Joule (C) Foot-pound (D) magnetic only.
7. Force can be: (A) mechanical only (B) electrical only (C) magnetic, mechanical or electrical (D) magnetic only.
8. When the power used by an electrical circuit is one watt, work is being done in that circuit at the rate of (A) 0.74 ft. lb. per sec. (B) 1 ft. lb. per sec. (C) 550 ft. lb. per sec. (D) 75 ft. lb. per sec.
9. When the power used by an electrical circuit is one watt, work is being done in the circuit at the rate of .74 ft. lbs. per sec. (A) always (B) sometimes (C) never.
10. The watt, kilowatt, foot-pounds per sec., and joules-per-second all measure (A) work (B) Force (C) Power.
11. When a battery is fully charged it is capable of doing work, To indicate this capacity for doing work and battery is said to store: (A) power (B) force (C) energy (D) work.
12. To find the rate at which work is being done (power) divide the total work done by the time required to do it (true) (false).
13. To find the total work done multiply the rate at which work is being done (power) by the time (true) (false).
14. When work is being done in the electrical circuit at the rate of 0.74 foot pounds per second, the power absorbed is: (A) one watt (B) 74 watts (C) one watt-hour (D) one joule.
15. When one ampere of current is forced through a resistance of one ohm, work is being done in the circuit at the rate of (A) one kilowatt (B) one watt (C) one joule (D) one watt-hour.
16. The watt-hour, kilowatt-hour, joule, and foot-pound are all units of: (A) power (B) work (C) force.
17. The answers to the problems are A () B () C ()

Coulomb	q or Q	Unit of electrical quantity. The quantity which will deposit .0000116 oz. of copper from one plate to the other in a copper sulphate solution. The quantity of Electricity which must pass a given point in a circuit in one second to produce a current of one ampere.
Ampere	I or A	Unit of current. (Rate of Flow) One coulomb per second.
Milliampere	MI or MA	.001 I (The prefix "milli" means one-thousandth)
Microampere	μ I or μ A	.000001 I (the prefix "micro" means one-millionth)
Volt	E or V	Unit of pressure. (EMF - Electromotive Force) The pressure required to force current at the rate of one ampere through the resistance of one ohm.
Millivolt	ME or MV	.001 E One-thousandth volt.
Microvolt	μ E or μ V	.000001 E One-millionth volt.
Kilovolt	KV	1000 E (The prefix "kilo" means one-thousand)
Ohm	R or Ω	Unit of resistance. A measure of the opposition offered to the flow of current. The resistance offered by a column of mercury 106.3 centimeters long and 1 square millimeter in cross sectional area, at a temperature of 32 degrees Fah., or 0 degrees Cent.
Megohm	Meg.	1,000,000 R One-million ohms.
Microhm	μ R	.000001 R One-million ohm.
Mho	g	Unit of conductance. A measure of the ease which a conductor will permit current to flow. It is the reciprocal of resistance.
Watt	W	Unit of power. One watt is equal to current at the rate of one ampere under the pressure of one volt. $W = I \times E$.
Horsepower	HP or HP	746 W The power required to raise 33,000 pounds, one foot, in one minute.
Milliwatt	MW	.001 W One-thousandth watt.
Kilowatt	KW	1000 W Unit of power.
Watt-hour	WH	Unit of work. (Power x Time) $W \times H = WH$
Kilowatt-hour	KWH	1000 WH Unit of work.
Farad	C	Unit of capacitance. Capacity of condensers.
Microfared	Mfd. or μ F	.00001 C One-millionth farad.
Micro-microfarad	MMF	.000001 mfd. One-millionth microfarad.
Henry	L or H	Unit of inductance.
Millihenry	ML or MH	.001 L One-thousandth henry.

DIRECT CURRENT APPARATUS

This section shows internal and external wiring for devices and equipment that operate with direct current. The pages are grouped in the following order of subjects:

Motors, also general principles	Testing
Generators or dynamos	Starters and controllers
Armature windings	

Except in the group devoted to starters and controllers most of the pages include explanations of the diagrams. The following additional notes apply to certain of the pages, as referred to by number.

PAGE 82

This sheet shows simple schematic diagrams for series, shunt and compound motors, and on the right-hand margin lists the connections from the power line to the motor terminals for counter-clockwise (CCW) rotation and for clockwise (CW) rotation. The following abbreviations are used:

A1 and A2. Armature L1 and L2. D-c power line connections

F1 and F2. Shunt field Comm. Commutating connections

S1 and S2. Series field connections

PAGE 90

Here, on a single chart, is the whole story of motor operating characteristics and applications. Going from left to right on the chart you find the speed characteristics, kind of electric power, construction and windings, usual horsepower, starting and stalling torque as compared with normal full load torque, variations of speeds with loads, the principal performance features of the motor, and finally the drives or applications for which each motor is especially well suited. Careful study of this table will add greatly to your knowledge of motors and their uses.

PAGES 97 AND 98

These diagrams of General Electric direct current

machines illustrate how winding connections and external terminal connections are shown.

PAGE 99

On this page is described a method for measuring the performance of a generator and plotting the performance as a curve showing the relations between current and voltage. Measurements are made with a voltmeter and ammeter, while the load is varied by using a rheostat consisting of metallic plates in a salt water bath. This description applies to methods followed in the Coyne shops, but illustrates the general procedure for similar work done elsewhere.

PAGE 111

This sheet shows how records are made and kept for armature winding repair jobs. Entries are made under the heading "REWIND DATA" as the armature is being stripped. Positions to which coil leads connect on the commutator are shown on the large central diagram. On this diagram are entered the numbers of the core slots in which lie the coil sides. Below the coil diagram are shown two sets of commutator bars as they would appear if laid out flat. On one set the center of a bar is on the center line of a coil. On the other set the insulation between bars is on the coil center line. Coil leads are run down to bars on whichever commutator arrangement is used on the armature being wound or repaired.

PAGE 115

This sheet shows the construction, winding, and connections for a growler. A growler is a device which generates voltages and currents in the coil windings of an armature laid on the field poles of the growler. Readings of armature currents are made as shown on the following page. Correct interpretation of readings allows determining the kind of trouble and its approximate location.

PAGE 122

These symbols are used in diagrams for motor starters and controllers for both direct-current and

symbols as you read from left to right across the successive lines from top to bottom of the page.

N.O. means "normally open." N.C. means "normally closed." A blowout is a device, usually an electromagnet, which lessens sparking as current-carrying contacts separate. Main circuits are those carrying line power. Auxiliary circuits usually are control circuits. An interlock is a connection, either mechanical or electromagnetic, that causes certain contacts to operate when other contacts operate, or which cause any two actions to occur simultaneously.

Note that on double-circuit push buttons there are four small circles indicating the four terminal connections for the two lines. In a maintained contact push button one terminal always remains connected to the switch contacts. A limit switch is a switch operated automatically when some portion of a machine reaches the limit of its travel; as, for example, on a machine tool where the motor is to be stopped or reversed when the cutter reaches the end of its travel.

A thermal overload relay opens its circuit when excessive current has continued for long enough to heat and expand a member that releases the contacts.

An auto-transformer is a transformer in which part of the winding is in both the primary circuit and the secondary circuit. A potential transformer transfers voltage changes from one circuit to another without having conductive connections between the circuits. A current transformer transfers current changes from one circuit to another. Potential transformers and current transformers often are called instrument transformers, since their usual purpose is to connect voltage-operated and current-operated instruments to circuits in which changes of voltage and current are to be measured or indicated.

PAGE 131

The lower right-hand diagram shows the motor armature and field windings connected directly to one side of the line. The other side of the line, L1, connects through a starter to the remaining terminals of the motor. Either of the starters may be used. Both starters are of the "face plate" type on which the power arm or handle is moved slowly from left to right across contact points between

which are resistors mounted on the back of the starter face plate. When the handle reaches the right-hand end of its travel it is held there by an electromagnet marked "No E (voltage) or no field release coil." Should line voltage fail or should it drop below a safe operating value, this release coil is demagnetized to an extent that releases the arm. Then a spring moves the arm back to the left-hand off position.

The upper right-hand diagram shows a starter equipped with the no-voltage release coil, also with an overload release coil. The overload release coil is a magnetic switch that opens the line circuit should the current rise above a safe operating value.

PAGE 132

This is a setup diagram for testing the horsepower output of a motor with a prony brake and for testing the efficiency by measuring the amperage and voltage from which are computed the electrical power input in watts (amperes x volts). The voltmeter and ammeter are mounted on a separate panel shown at the upper right.

PAGE 133

The first movement of the power arm toward the right allows closing of the contacts shown at the bottom of the arm. Current from L1 at the line switch then flows through these contacts, through the starting relay winding, and to L2. The starting relay contacts close. Then current from L1 flows through the magnetic blowout coil, the relay contacts, and the power arm so that the starter operates as usual.

PAGE 134

The upper left-hand starter is used for starting the motor, then for increasing its speed above normal. The power arm consists of two parts. The motor is started by moving the arm slowly toward the right, as usual. At the extreme right-hand of the travel one part of the arm is held in place by the no-voltage release magnet. Then the other section of the arm is moved backward, to the left, to increase the motor speed. Moving this section of the arm to the left allows its contact to travel across contact points between which are sections of the field resistance. Thus more and more resistance is connected in series with the shunt field of the motor, which has the effect of increasing the motor speed.

The upper right-hand starter has resistors which are heavy enough and which will dissipate enough heat so that the power arm may be left at any position along its travel. The position of the arm determines the amount of resistance in series with the armature and the series field of the motor. The greater this resistance the slower the motor will run.

PAGE 138

The stationary contacts of the drum controller are shown by circles. The contact shoes which are on the drum and which move with the drum are shown by rectangular outlines. All the shoes move together, either to the right or to the left on the diagram.

PAGE 147

When the motor is to be started with the solenoid starter the start switch button (upper right) is pressed to close the switch contacts. Current from the line (L1) flows through the solenoid magnet winding to terminal C1, through the closed stop switch contacts, the closed start switch contacts, to terminal C3, and back through L2 to the other side of the line. The solenoid plunger rises, and with it the power arm. The power arm short circuits and cuts out more and more of the armature starting resistance as the motor starts and gains speed. Opening the stop switch by pressing its button opens the circuit through the solenoid winding, thus allowing the plunger and power arm to drop and open the motor circuit.

PAGE 149

In tracing the diagrams on this and following pages refer to the symbols shown and explained on page 124.

In relays Type J-30 and Type J-31 closing the contacts of the control device (any suitable switch) lets control circuit current flow through the relay magnet winding represented by a circle on the right-hand heavy conductor. The magnet closes the contacts shown above the circle and allows current to flow to the load.

On the right-hand side of the page the upper diagram is a connection diagram or wiring diagram for the starter, the start and stop push button switch, and the shunt wound motor. The lower diagram is a schematic in which it is easy to trace the current paths. On the lower line of the schematic diagram the contacts in series with the motor are marked M. These contacts are closed and

opened by the double wound electromagnet coil. One winding is energized by closing the start switch. Auxiliary contacts, shown inside the starter of the upper diagram, are holding contacts which close and maintain a circuit through the second coil until the stop button is pressed to open the entire control circuit.

PAGE 150

In this starter there is a relay, AR, on the moving plunger of which is a dashpot that allows the plunger to move only slowly while the coil is energized. The slow movement of the plunger successively closes contacts that short circuit resistor sections R2, R3 and R4, thus reducing resistance in the armature circuit as the motor gradually gains speed.

PAGE 151

Of the two upper diagrams the one at the left shows terminal connections and the one at the right shows the schematic circuits. Pressing the FOR (forward) button sends current through the armature and commutating (COM.) field in one direction and causes the motor to rotate say clockwise. Pressing the REV (reverse) button reverses the direction of current in the armature and commutating field, which reverses the direction of motor rotation. On the schematic diagram the forward contacts are marked F and the reversing contacts are marked R. There are two relay magnets, one forward and the other reverse, each operating its own set of contacts.

The two lower diagrams are schematic diagrams for starters providing both time limit and reversing features. A dashpot on the magnetic relays limits the rate at which they close their contacts, thus cutting out armature resistance in one step after another at definite time intervals. The reversing feature operates similarly to that shown in the upper diagrams.

PAGE 153

This is a speed regulator that reduces the speed of the motor below normal by inserting more and more resistance, in series with the armature, and that increases the speed above normal by inserting resistance in series with the shunt field winding of the motor. Armature resistance is shown by heavy lines on the controller, while field resistance is shown by light lines. The action of this controller is similar to that of the ones shown on page 136.

D.C. MOTORS AND GENERATORS.

OPERATION

The D.C. motor operates on the first law of magnetism which states that like poles repel and unlike poles attract. Current flowing through the field coils produces the field poles, and current through the armature coils develops armature poles midway between the field poles. Attraction and repulsion between these two sets of poles produces rotation. Note that the armature poles remain stationary in space.

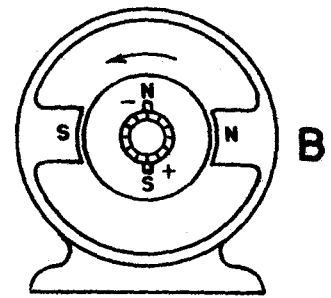
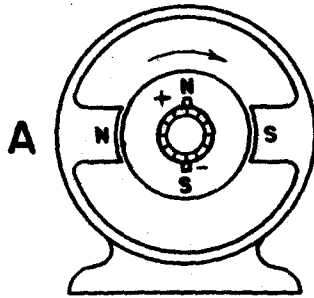

ROTATION

By reversing the direction of current flow through the fields or through the armature, the field poles or the armature poles will be reversed, and the direction of rotation changed. Compare A with B and C with D.

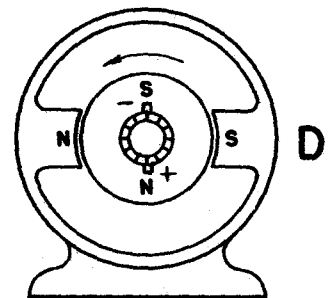
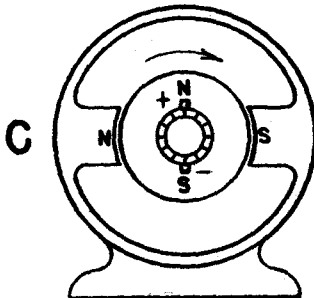

ARMATURE POLES

Diagrams E and F show a 4 pole motor. Note that the number of armature poles always equals the number of field poles, and that the armature poles are located midway between the field poles. From the above it is obvious that a 2 pole armature will not work in a 4 pole field. Note also that when the direction of current flow is reversed all poles are reversed.

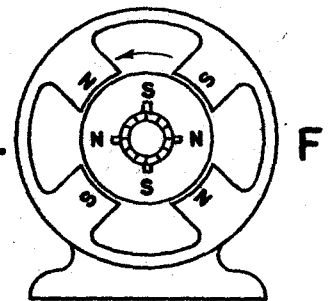
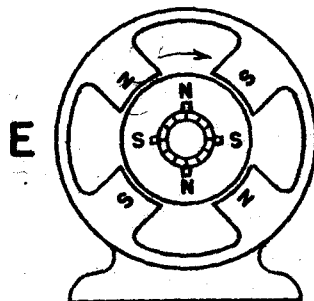

GENERATORS

Diagrams G and H show two generators, one arranged for clockwise and the other for counter clockwise rotation. Note that poles are set up on generator armatures also, but that in this case the poles oppose rotation. As more current is drawn from the armature, these poles increase in strength; this explains why an electric generator is harder to drive as the armature current increases.

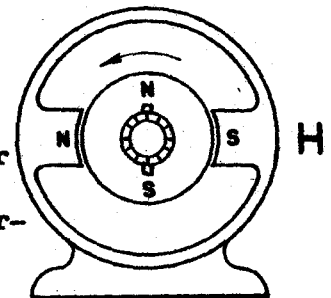
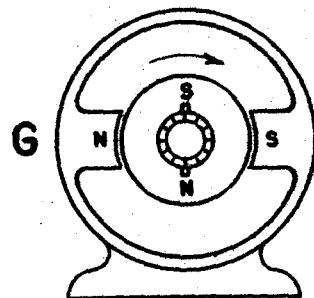

D.C. MOTORS AND GENERATORS.

INTERPOLES

To minimize sparking at the brushes, most D.C. motors are equipped with small poles placed midway between the main poles and called interpoles or commutating poles. For proper operation, these small poles must have the correct polarity. Reference to any of the diagrams will show that the polarity of the interpole is always the same as the armature pole adjacent to it.

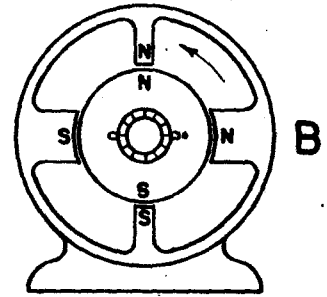
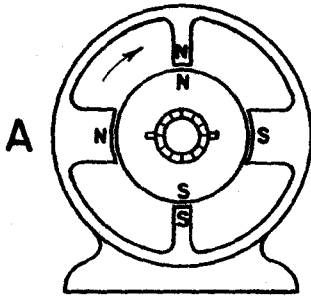

REVERSING ROTATION

The windings on the interpoles are always connected in series with the armature winding and are considered a part of the armature circuit. Therefore, when current through the armature is reversed, the interpole polarity is also reversed. This arrangement automatically preserves the proper relation between the armature poles and the interpoles when the armature current is reversed.

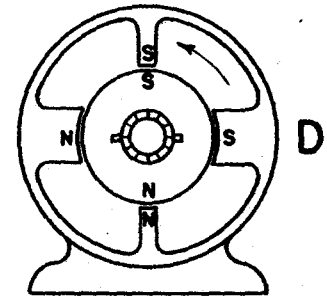
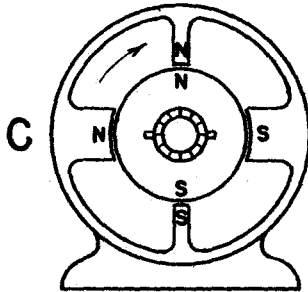

NUMBER OF INTERPOLES

Machines equipped with interpoles may have as many interpoles as main poles or one-half as many interpoles as main poles. As the interpole winding is always connected in series with the armature, the interpole strength will vary with the value of armature current.

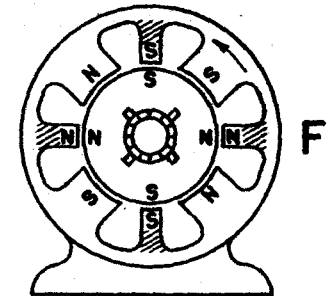
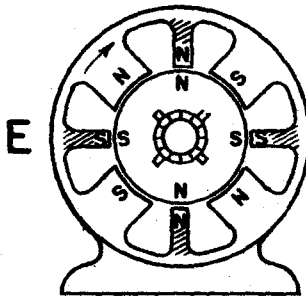

GENERATORS

Diagrams G and H show two generators equipped with interpoles. G is arranged for clockwise rotation and H for counter clockwise rotation. Note that the rule for the polarity of interpoles applies to generators as well as motors. Note too, that the armature poles oppose rotation and thus produce the force against which the prime mover must work to maintain rotation.

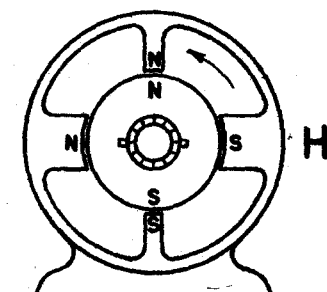
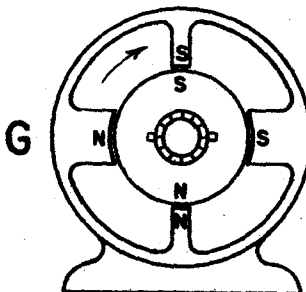

D. C. MOTOR PRINCIPLES

Electric motors are machines that change electrical energy into mechanical energy. They are rated in horse power. (H.P.)

The attraction and repulsion of the magnetic poles produced by sending current through the armature and field windings causes the armature to rotate. The armature rotating produces a twisting power called torque.

Fleming's Left Hand Rule For Motors

Place the thumb, first finger and remaining fingers at right angles to each other. Point the first finger in the direction of the field flux, remaining fingers in the direction of the armature current and the thumb will indicate the direction of rotation.



The direction of rotation can be reversed on any D.C. motor by reversing either the armature or field leads but not both. It is standard practice to reverse the armature leads to reverse the direction of rotation.

The amount of torque developed by a motor is proportional to the strength of the armature and field poles. Increasing the current in the armature or field winding will increase the torque of any motor.

The armature conductors rotating through the field flux has a voltage generated in them that opposes the applied voltage. This opposing voltage is called counter electro motive force, (C E M F) and serves as a governor for the D.C. motor. After a motor attains normal speed the current through the armature will be governed by the C E M F generated in the armature winding. This value will always be in proportion to the mechanical load on the motor.

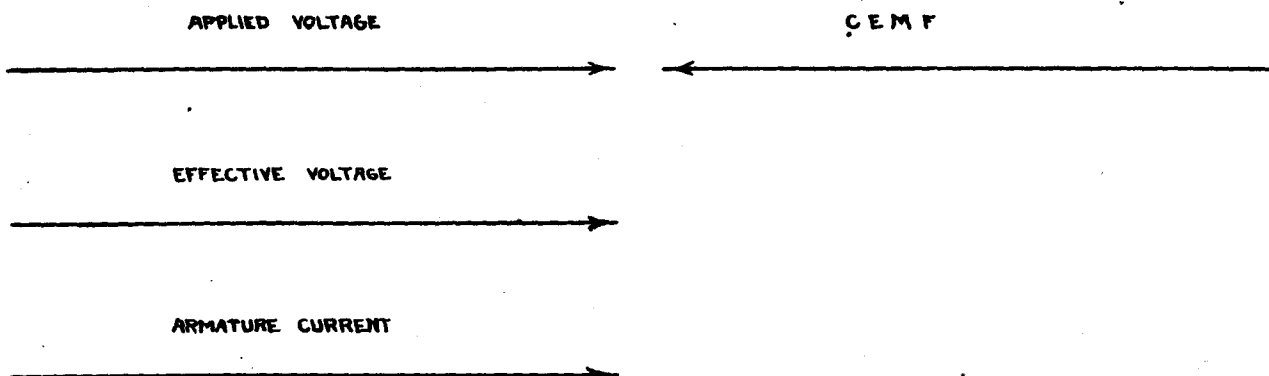

D.C. MOTOR PRINCIPLES (CONTINUED)

The applied voltage is the line voltage. The effective voltage is the voltage used to force the current through the resistance of the armature winding. This value can be determined by multiplying the resistance of the armature by the current flow through it. To find the resistance of the armature measure the voltage drop across the armature and the current flow through it and use ohm law formula. R equals E over I

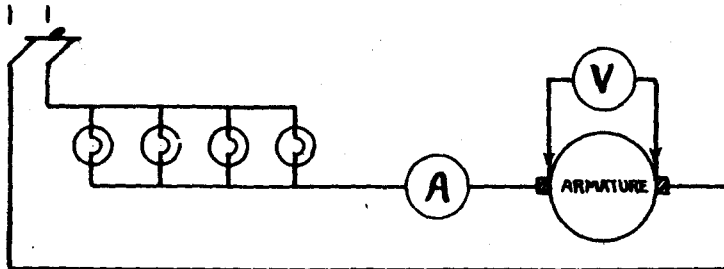

The lamps are used to limit the current through the armature winding.

The revolutions per minute of a D.C. motor can be varied over a wide range. The maximum safe speed for the average D.C. machine is 6000 ft. per minute peripheral speed of the armature. D.C. motors can be designed to operate safely up to 15,000 peripheral ft. per minute. Periphery means outer surface.

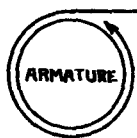

2 ft. circumference

$2 \frac{6000}{3000}$ R.P.M. is the maximum safe speed for the average D.C. machine that has an armature that is 2 ft. in circumference

The H.P. rating of a motor refers to the rate of doing work. The amount of H.P. output is proportional to the speed and torque developed by the motor. The Prony Brake Test is used to determine the H.P. output of a motor.

PRONY BRAKE FORMULA

$$H.P. = \frac{2\pi \times P \times L \times R.P.M.}{33,000}$$

- 2π equals 6.28
- P " Pull on the lever arm in lbs.
- L " Length of the lever arm in ft.
- R.P.M. equals Revolutions per minute.

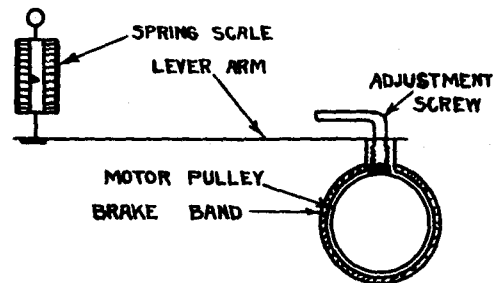

$$EFFICIENCY = \frac{OUTPUT}{INPUT}$$

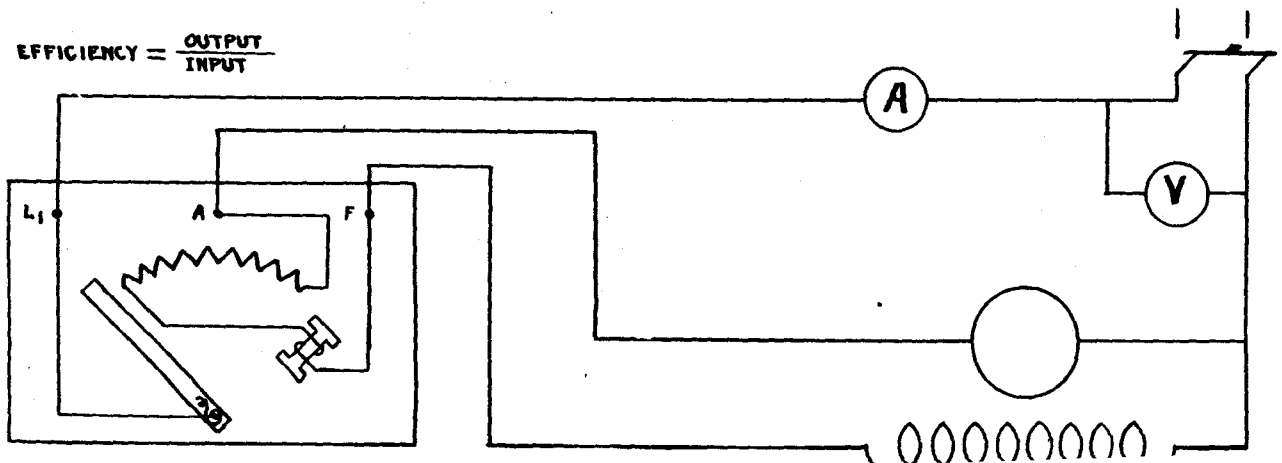

SHUNT MOTOR

A shunt motor is a motor that maintains nearly constant speed from no load to full load. The shunt field winding consists of many turns of small wire and is connected parallel with the armature winding or across the line. The diagrams below show the proper connection for the armature and field.

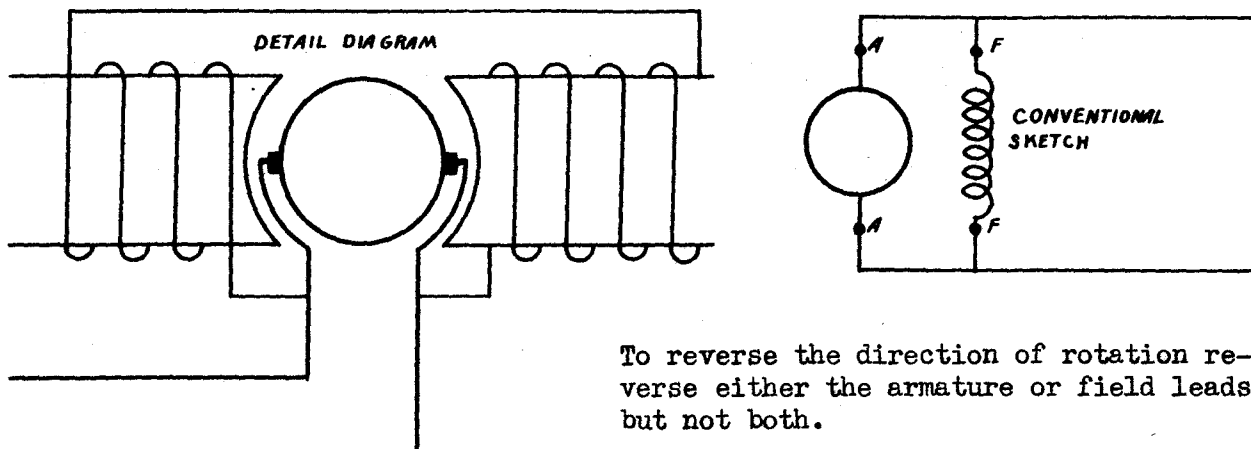

To reverse the direction of rotation reverse either the armature or field leads but not both.

The characteristic curves below show that the torque developed by a shunt type motor varies with the armature current. This is true because the torque is proportional to the armature and field flux. The field maintains constant strength because it is connected across the line and the armature flux will vary with the armature current. The torque of a shunt motor is considered to be fair in comparison to other D.C. motors. It will start about 50% overload before being damaged by excessive current.

The shunt type motor maintains nearly constant speed from no load to full load because the shunt field strength is constant. The characteristic curve shows that the speed varies about 10% from no load to full load which gives this motor very good speed regulation.

This motor is widely used where it is desired to control the speed above and below normal speed. A shunt field rheostat connected in series with the shunt field will cause the motor to increase in speed. A resistor connected in series with the armature will cause the motor to decrease in speed.

Shunt motors sometimes have a few turns of heavy wire wound on each field pole and connected in series with the armature. This winding produces the same polarity as the shunt field winding and produces a more stable operation when the motor is carrying a fluctuating load.

For applications of the shunt motor see Motor Application Chart Number 115.

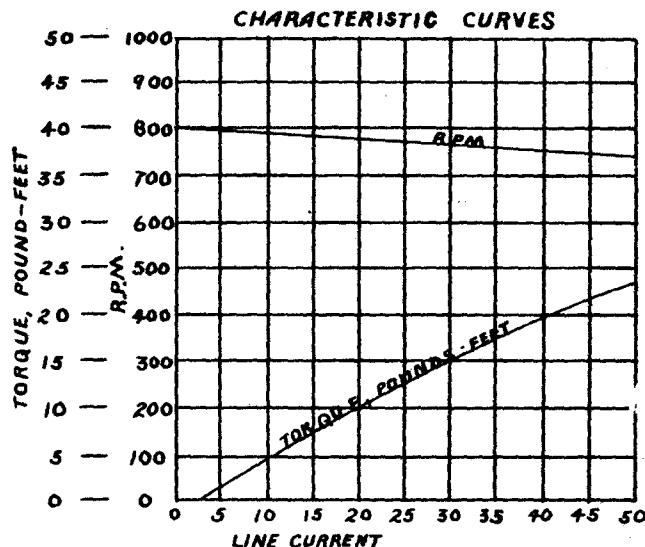

SERIES MOTOR

A motor that has its field and armature connected in series with each other is a series type motor. The field is constructed of a few turns of heavy wire or strap conductor. The field strength will vary with the armature current under normal conditions.

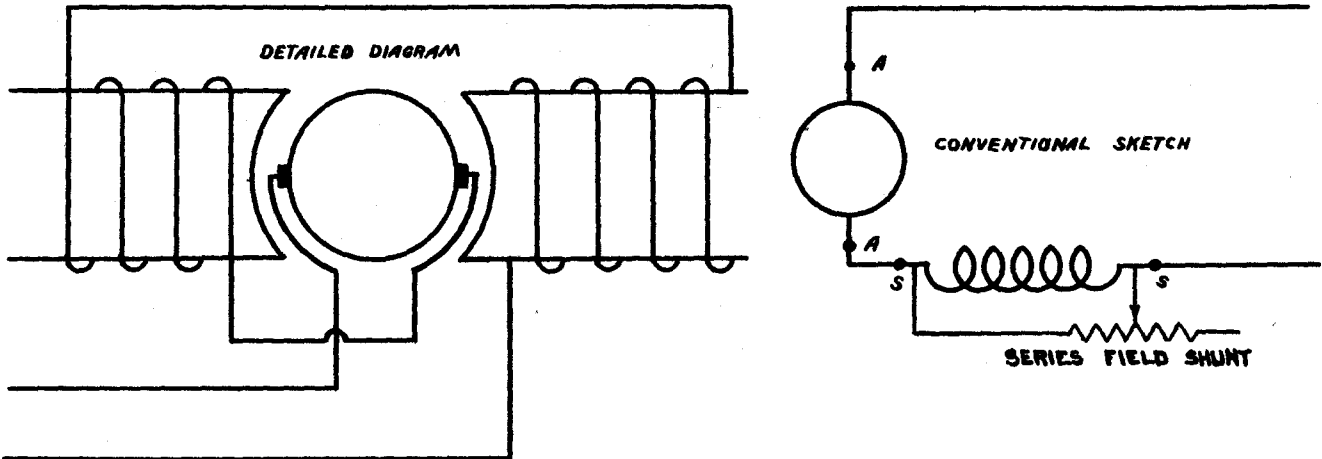

The starting and stalling torque is excellent. It will start or carry very heavy overloads. The torque of a series motor varies with the square of the armature current. This is true because the field strength varies with the armature current. Example - Doubling the armature current will likewise double the field strength and produce four times as much reaction between armature and field poles or produce four times as much torque.

The speed regulation is very poor. The speed varies inversely with the load which means more load less speed and less load more speed. Care must be taken to see that there will always be sufficient load on the motor to keep the speed within safe limits. If the load drop to zero the motor probably would run fast enough to destroy itself.

The series motor is limited in application because of its poor speed regulation. It is especially suitable for cranes, hoists, mine machines and electrical railway work. These loads can be handled more efficiently with a series motor because the speed will be slow if the load is heavy and a light load will be driven at a high speed.

The speed of a series motor can be controlled above normal speed by connecting a series field shunt parallel to the series field. The speed will vary inversely with the field strength. Controlling the speed above normal decreases the possible torque output but does not affect the H.P. output.

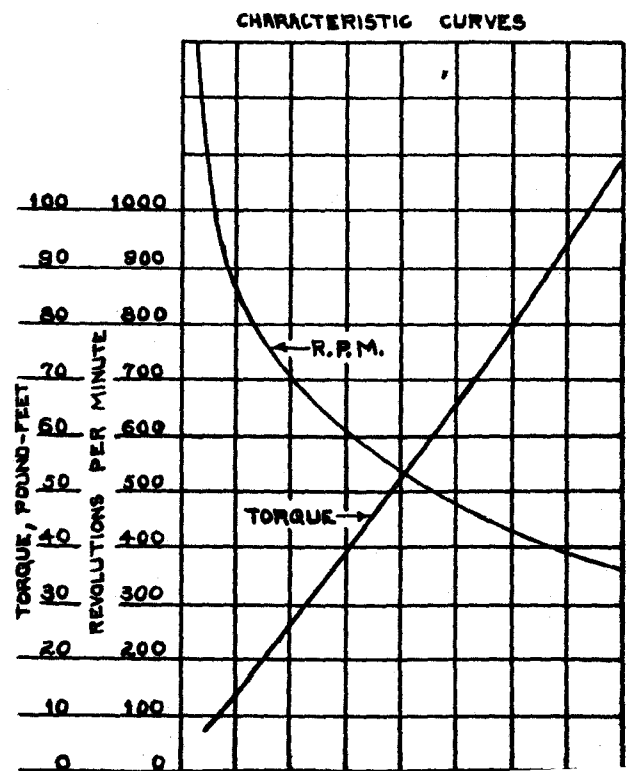

COMPOUND MOTOR

The field of a compound motor is made up of shunt and series coils placed on each field pole. The shunt winding is the main field winding. The series is the compound winding and its strength varies with the load current. If the shunt and series coils produce the same polarity at each field pole the connection is known as CUMULATIVE COMPOUND.

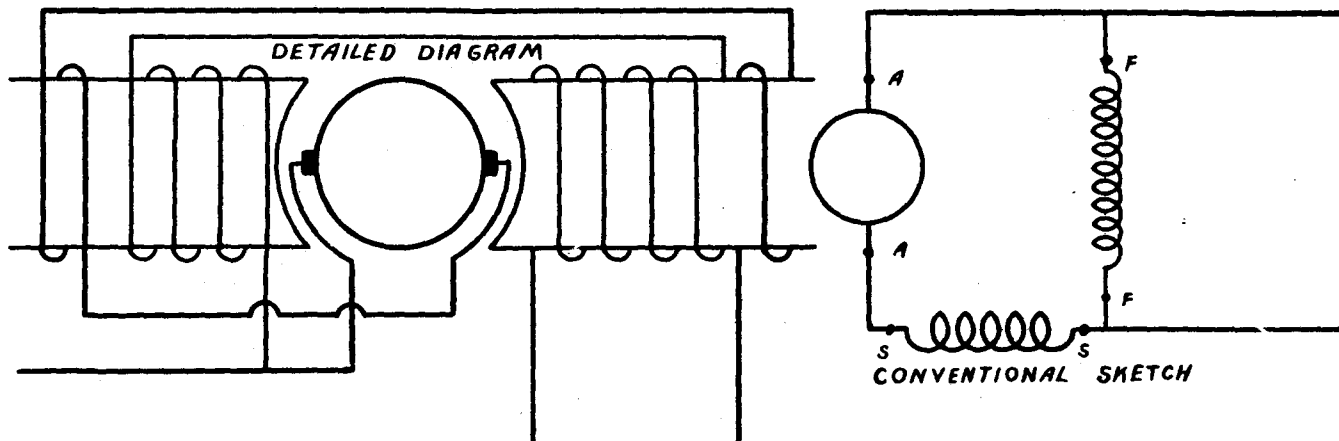

COMPOUND MOTOR CONNECTED CUMULATIVE

The TORQUE is very good. It will start to carry heavy overloads. The cumulative connected compound motor produces a better torque than the shunt motor but not as good as the series motor.

The SPEED REGULATION is fair. The speed will vary from 15 to 25% from no load to full load. The per cent variation in speed from no load to full load will be governed by the comparative strength of the shunt and series field.

The CUMULATIVE CONNECTED COMPOUND MOTOR is suitable for jobs, such as, compressors, crushers, steel mill roll, etc. For a complete list of applications see chart #115.

DIFFERENTIAL CONNECTED COMPOUND MOTOR

If the polarity of the series field oppose the shunt field the connection is known as differential compound.

The SPEED REGULATION of a differential connected compound motor is very good up to approximately 75% of full load rating. It is apt to slow down or stall if loaded beyond that point.

The TORQUE is very poor. It is apt to start and then reverse its rotation when starting a load.

There is very little use for the differential compound motor.

TESTS TO USE TO DETERMINE CONNECTION MADE FOR COMPOUND MOTOR.

1. Test the speed as connected. Reverse the series field leads and retest the speed. The connection producing the higher speed will be differential compound.
2. Operate the motor as a shunt motor. (series field disconnected) Observe the direction of rotation. Next operate the motor as a series motor. (shunt field disconnected) Again observe the direction of rotation. If each field connection produces the same direction of rotation. If each field connection produces the same direction of rotation, reconnect the fields the same as when testing and the motor will be cumulative compound.

CHARACTERISTIC CURVES

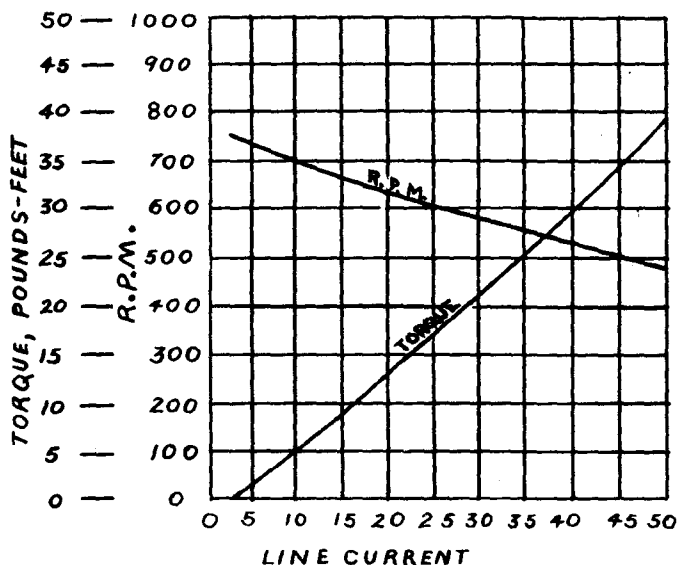

UNIVERSAL SERIES MOTOR

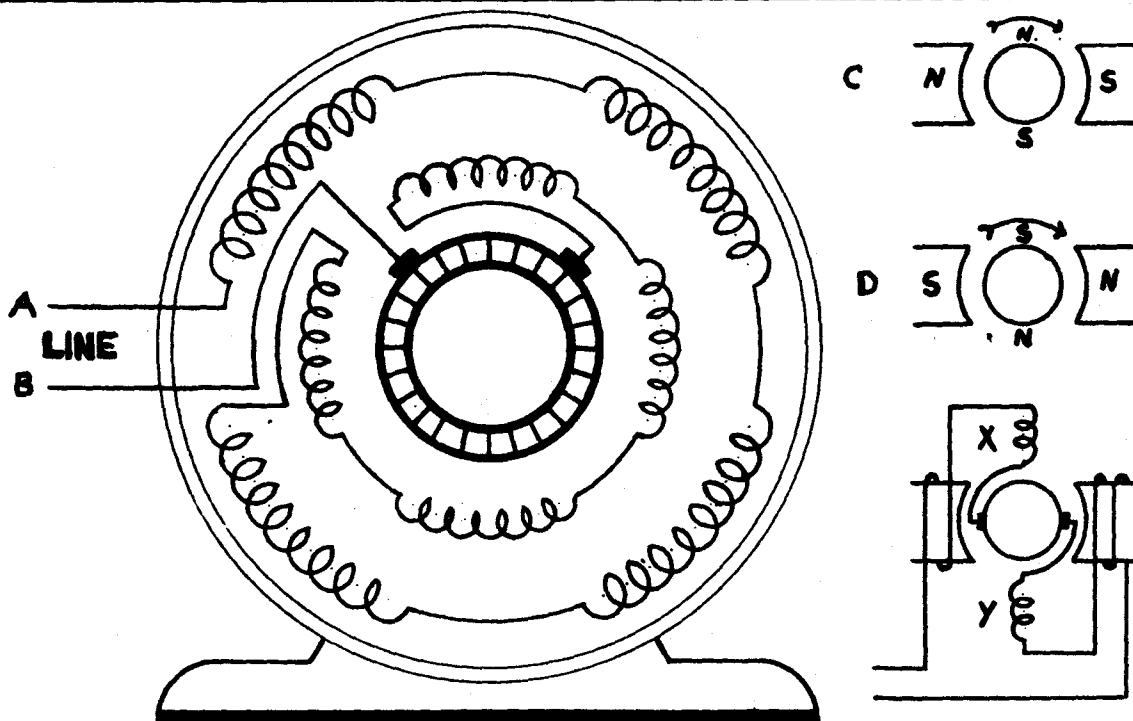

The above motor operates on the magnetic interaction between the armature and field poles, and runs in the same direction whether the current flows in on line A or line B, since reversing the flow of current in the line wires changes the polarity of both armature and field poles at the same instant as shown at C and D. Therefore, if such a motor be supplied with A.C. the torque developed will always be in the same direction. Since this machine operates on both D.C. and A.C. it is called a Universal motor. To operate satisfactorily on A.C. all parts of the magnetic circuit must be laminated to prevent undue heating from eddy currents, and element windings are usually desirable on the armature to ensure acceptable commutation. On the larger motors compensating windings are employed to improve operation and reduce sparking.

CHARACTERISTICS

This motor will produce about 4 times normal full load torque with 2 times normal full load current. The torque produced increases very rapidly with an increase in current as the curves below indicate. The variation in speed from no load to full load is so great that complete removal of load is dangerous in all motors of this type except those having fractional H.P. ratings.

APPLICATIONS

This motor is widely used in fractional H.P. sizes for fans, vacuum cleaners, kitchen mixers, milk shakers, and portable equipment of all types such as electric drills, hammers, sanders, saws, etc. Higher ratings are employed in traction work, and for cranes, hoists, and so on. In general, they are suitable for applications where high starting torque or universal operation is desired.

PRINCIPAL TROUBLES

Commutator, brushes, brush holders, bearings. Opens, shorts, or grounds in the armature, field, or associated apparatus. Loose connections.

To reverse the direction of rotation, reverse the armature connections or the field connections, but not both.

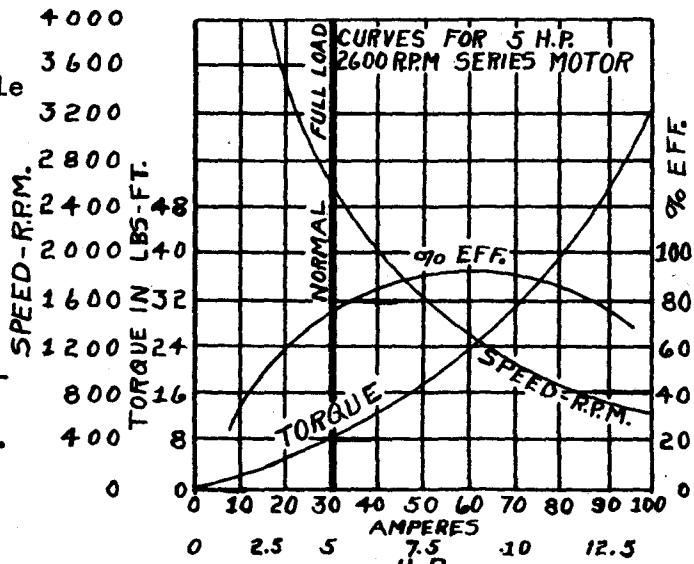

ENGINEERING INFORMATION
 CONNECTION DIAGRAMS FOR DIRECT CURRENT MOTORS
 SINGLE VOLTAGE, REVERSIBLE, WITHOUT OVERLOAD PROTECTION

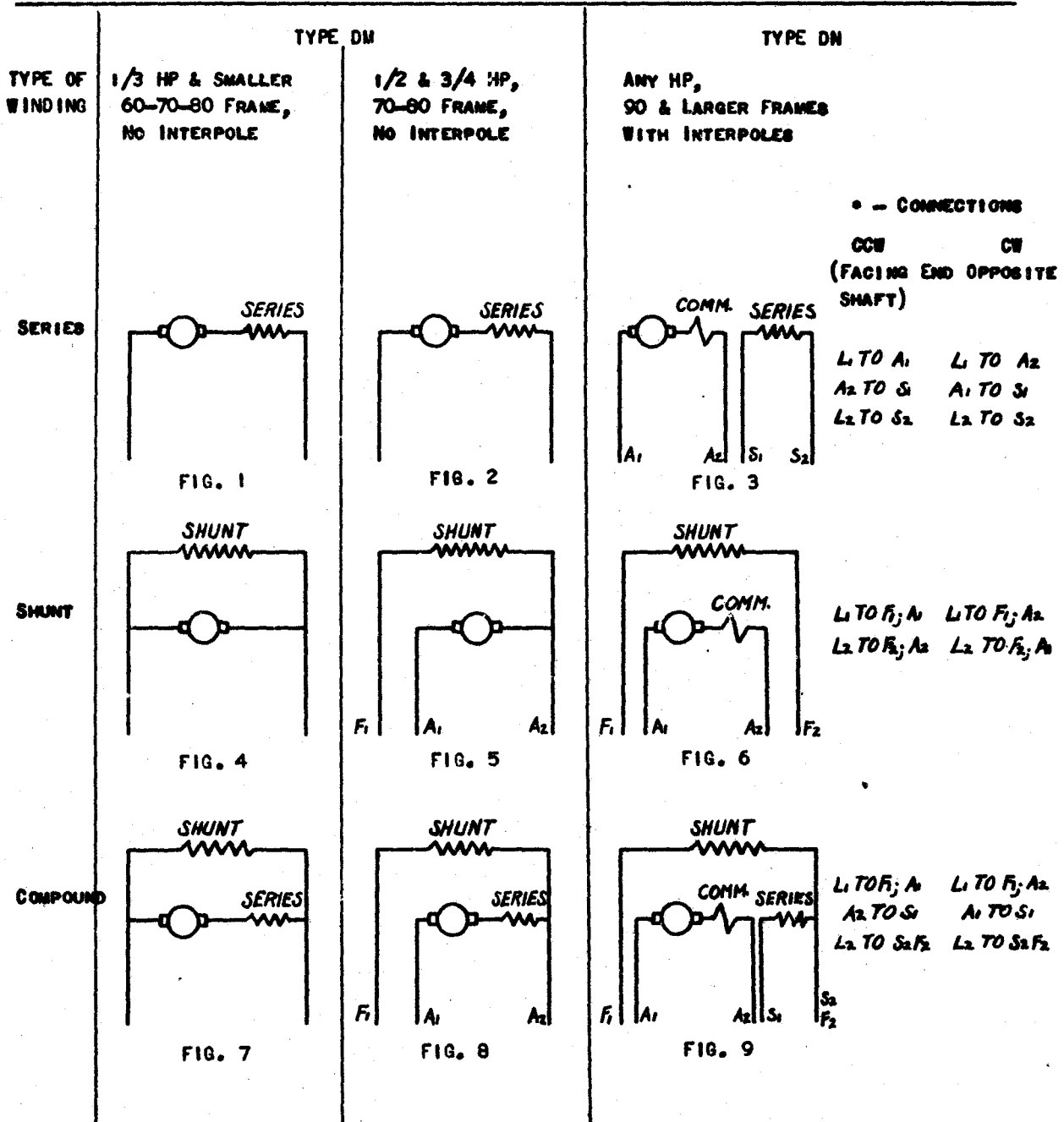

• - CONNECTIONS
 CCW CW
 (FACING END OPPOSITE
 SHAFT)

L₁ TO A₁ L₁ TO A₂
 A₂ TO S₁ A₁ TO S₂
 L₂ TO S₂ L₂ TO S₁

L₁ TO F₁; A₁ L₁ TO F₁; A₂
 L₂ TO F₂; A₂ L₂ TO F₂; A₁

L₁ TO F₁; A₁ L₁ TO F₁; A₂
 A₂ TO S₁ A₁ TO S₁
 L₂ TO S₂; F₂ L₂ TO S₂; F₂

TO REVERSE ROTATION INTERCHANGE LEADS
 AT BRUSH HOLDER; STANDARD ROTATION IS
 C.C.W. FACING END OPPOSITE SHAFT

TAG 882-A IS FURNISHED WITH THESE
 MOTORS.

• - CONTROL NOT COVERED - CONSULT
 CONTROL MANUFACTURERS
 DIAGRAM.

TAG 882-A AND CONNECTION DIAGRAM
 IS FURNISHED WITH THESE MOTORS.

D.C. MOTOR & GENERATOR CONSTRUCTION

D.C. power is widely used in the industrial field. This type of power must be used for telephones, field excitation, lifting magnets and electro plating work. The characteristics of D.C. Motors make them especially suitable for loads that are difficult to start, where the speed must be varied over a wide range, and where the load must be started and stopped often; such as, traction work, milling machines, mine work, lathes, pumps, steel mill work, printing presses, elevators, etc.

Any D.C. machine may be used as a motor or generator. This construction information applies to both machines.

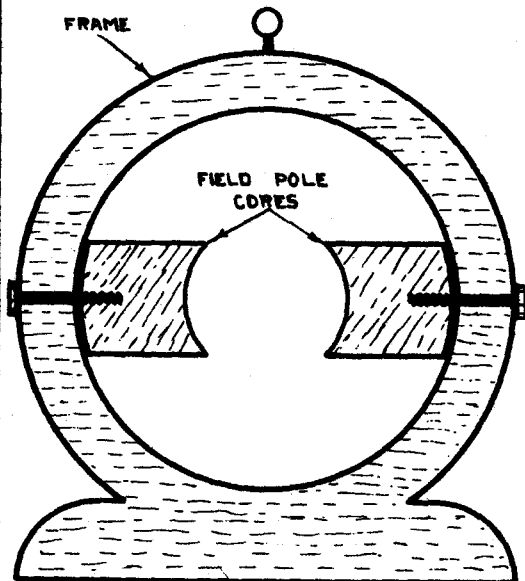

The frame is made of iron because it is used to complete the magnetic circuit for the field poles. Frames are made in three types; open, semi-enclosed and closed types. The open frame has the end plates or bells open so the air can freely circulate through the machine. The semi enclosed frame has a wire netting or small holes in the end bells so that air can enter but will prevent any foreign material entering the machine. The enclosed type frame has the end bells completely closed and the machine is air tight. Some machines are water tight which makes it possible to operate them under water. The closed type frame is used in cement plants, flour mills, etc. where the air is filled with dust particles that damage machine insulation.

The field poles are made of iron, either in solid form or built of thin strips called laminations. The iron field poles support the field windings and complete the magnetic circuit between the frame and armature core.

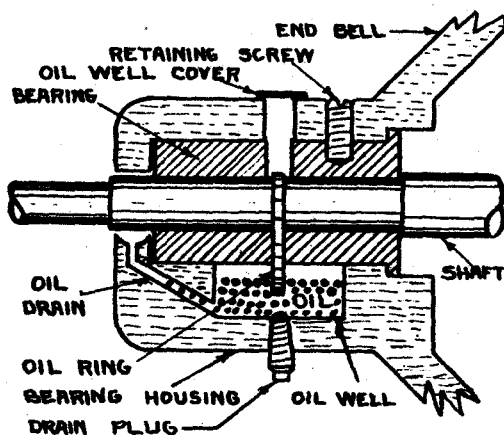

The bearings are the parts of the machine that fit around the armature shaft and support the weight of the armature. They are made in three general types; sleeve, roller, and ball bearings. Bearings will be discussed in detail later in the course.

The oil rings are small rings used with sleeve type bearings. They carry the oil from the oil well to the shaft. The oil ring must turn when the machine is operating otherwise the bearing will burn out.

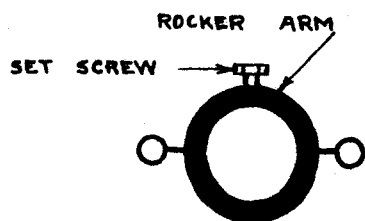

The rocker arm supports the brush holders. This arm is usually adjustable to make it possible to shift the brushes to obtain best operation. When the brushes are rigidly fastened to the end bell the entire end bell assembly is shifted to obtain best operation.

D.C. MOTOR & GENERATOR CONSTRUCTION (CONTINUED)

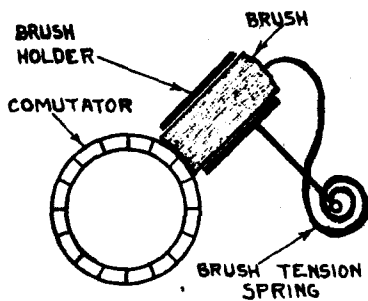

The brush holders support the brushes and hold them in the proper position on the commutator. The brushes should be spaced equi-distantly on the commutator when more than two sets of brushes are used. When only two sets are used they will be spaced the same distance as a pair of adjacent field poles.

The brush tension spring applies enough pressure on the brush to make a good electrical connection between the commutator and brush.

Brushes used on electrical machines are made of copper, graphite, carbon or a mixture of these materials. The purpose of the brushes is to complete the electrical connection between the line circuit and the armature winding.

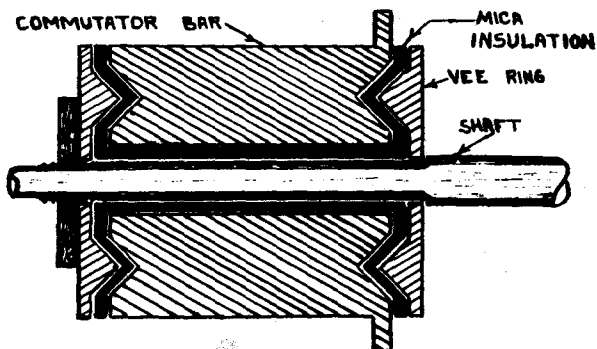

Commutators are constructed by placing copper bars or segments in a cylindrical form around the shaft. The copper bars are insulated from each other and from the shaft by mica insulation. An insulating compound is used instead of mica on small commutators. The commutator bars are soldered to and complete the connection between the armature coils.

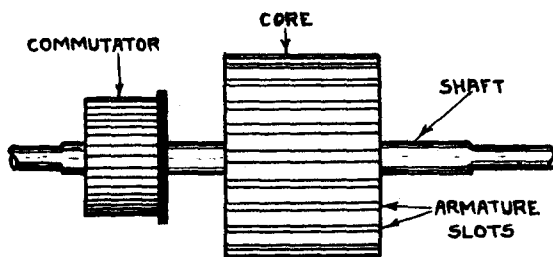

The armature core is made of laminated iron (thin sheets) pressed tightly together. The laminated construction is used to prevent induced currents (eddy currents) from circulating in the iron core when the machine is in operation. The iron armature core is also a part of the magnetic circuit for the field, and has a number of slots around its entire surface, in which the armature coils are wound.

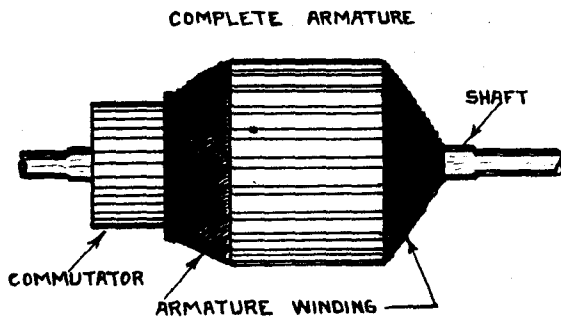

The armature winding is a series of coils wound in the armature slots and the ends of the coils connect to the commutator bars. The number of turns and the size of wire is determined by the size speed and operating voltage of the machine. The purpose of the armature winding is to set up magnetic poles on the surface of the armature core.

The field windings are made in three different types: shunt, series and compound wound fields. Shunt fields have many turns of small wire and series fields have a few turns of heavy wire. The compound field is a combination of the two windings. The name of the field winding depends on the connection with respect to the armature winding. The purpose of the field winding is to produce magnetic poles that react with the armature poles to produce rotation.

Brushes and Brush Setting

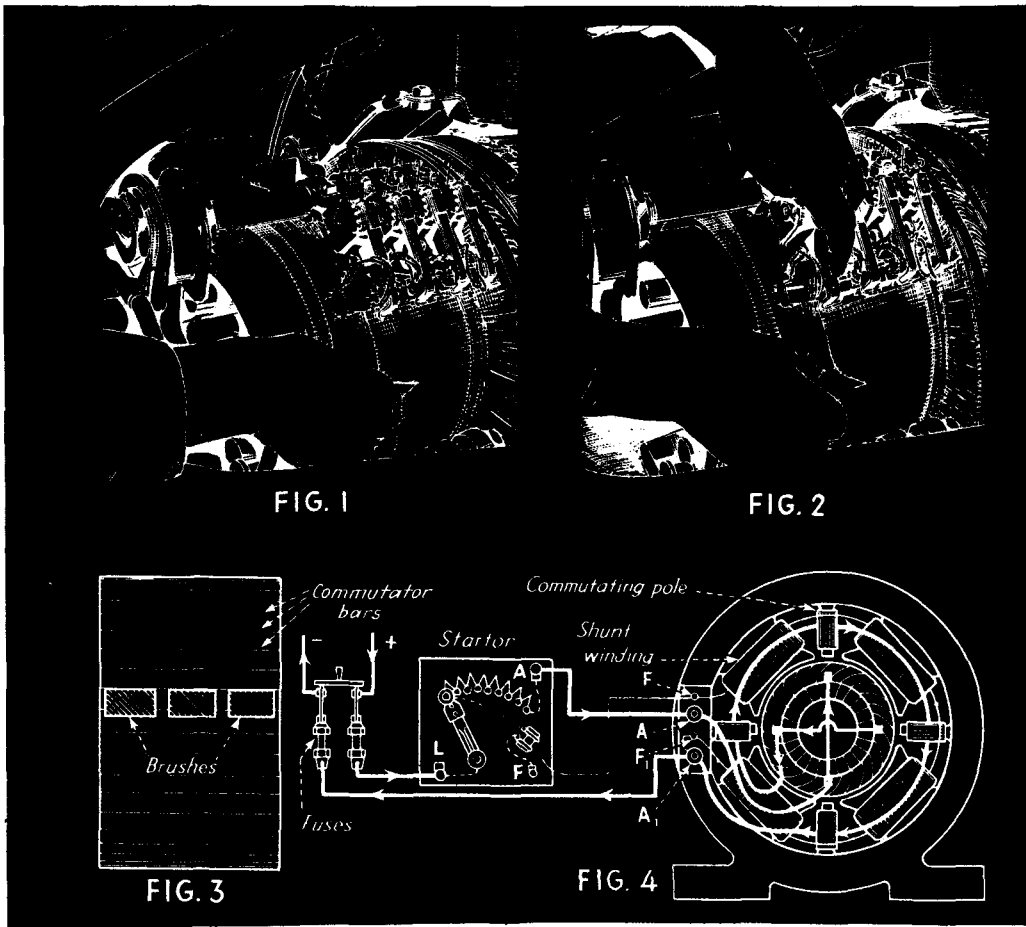

Figs. 1 and 2—Fitting brushes to commutator with sand paper. Fig. 3—Brushes in each group should be in line. Fig. 4—Field circuit open to test brush location on commutator

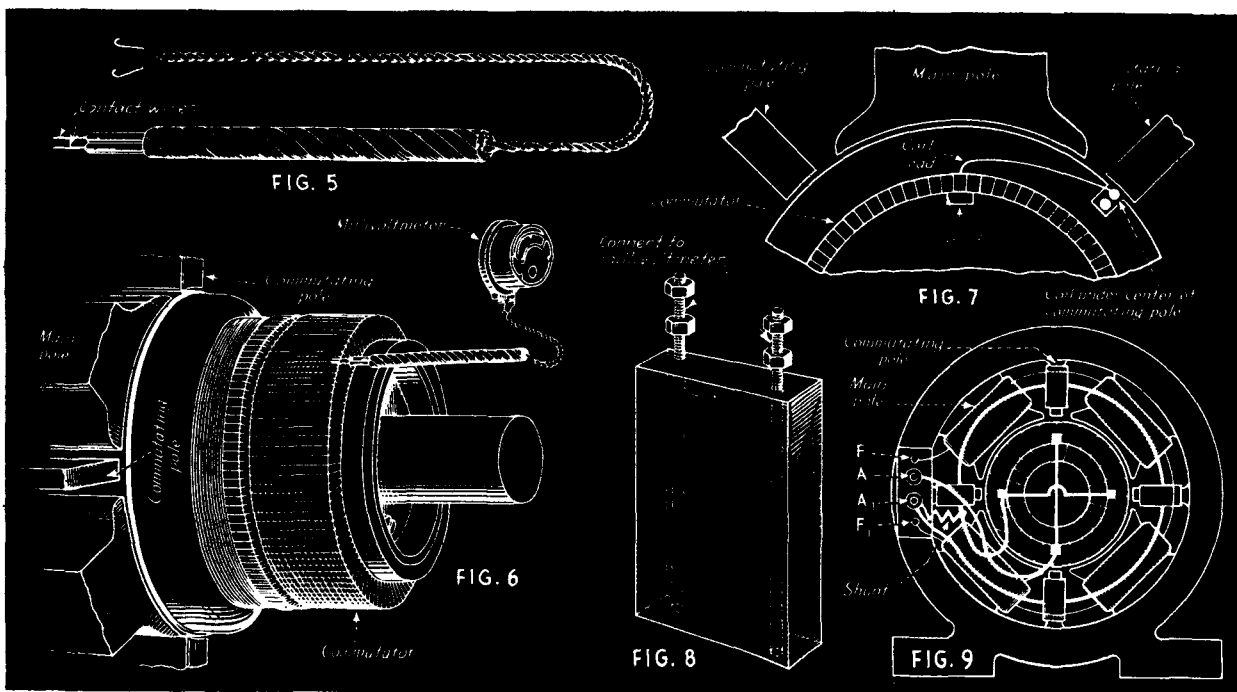

Figs. 5 and 6—Locating neutral on commutator with millivoltmeter. Fig. 7—Armature-coil lead locates neutral. Fig. 8—Fibre brush used with millivoltmeter. Fig. 9—Shunt across commutating-pole coil leads to adjust field-pole strength.

A MACHINE MAY FAIL TO START OR IMPROPERLY OPERATE DUE TO-

1. Opens, loose connections or high resistance contacts in the motor, line or starter. Use a test lamp or a voltmeter and make a continuity test as shown by sketch.

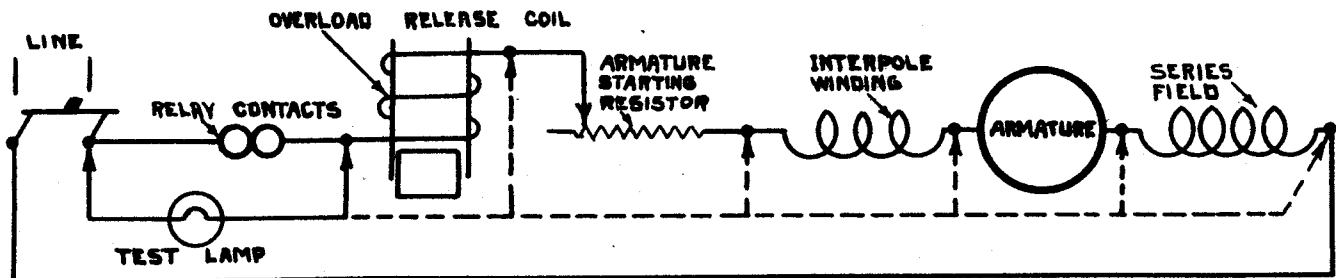

2. Worn bearings, on small machines and bearings can be tested by moving the shaft. If bearings are worn there will be a noticeable clearance between the bearing and shaft. For a more accurate test measure the air gap with an air gap or thickness gauge. For best condition the surface of all field poles should be the same distance from the armature core. Use the same position on the armature for all tests.

BEARINGS NOT WORN				WORN BEARINGS		
UPPER LEFT MEASUREMENT	''	.026"		UPPER LEFT MEASUREMENT	''	.044"
UPPER RIGHT	''	.026"	UPPER RIGHT	''	.044"	
LOWER	''	.026"	LOWER	''	.008"	
LOWER LEFT	''	.026"	LOWER LEFT	''	.008"	

3. Incorrect field pole polarity. Field pole polarity will not reverse itself. This trouble occurs when field connections are being made between coils. Adjacent poles should produce opposite polarity otherwise maximum field strength will not be produced. A weakened field will cause a motor to run at a speed higher than normal and decrease the amount of torque it will produce.

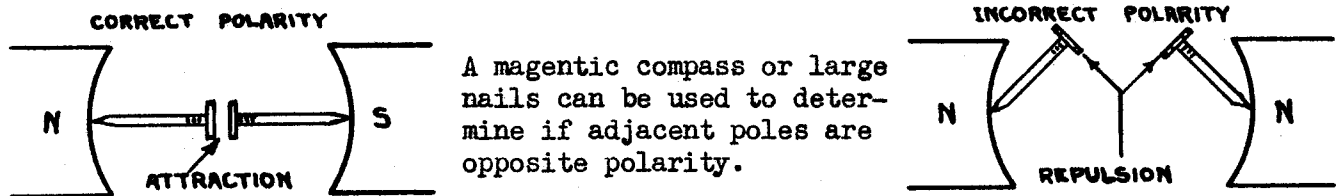

4. High or low line voltage. The armature of a shunt or compound motor will overheat if the line voltage is lower than normal if the motor is carrying its full load. High line voltage will cause the shunt field to overheat. Series motors will not be affected except the speed will vary with the voltage applied to the motor.

5. Operating temperatures. The temperature rating on the name plate is the amount of heat the machine will produce when operating with full load. The maximum operating temperature for any machine is the name plate temperature plus normal room temperature. Example - Name plate temperature 40 degrees centigrade - Normal room temperature is always considered to be 40 degrees centigrade. This machine will operate at a temperature of 40° plus 40° or 80° centigrade which is equal to 176 degrees fahrenheit. The following formulas are used to change fahrenheit to centigrade or vice versa. F equals (C times 1.8) plus 32 C equals (F minus 32) divided by 1.8.

MAINTENANCE & TROUBLE SHOOTING (continued)

6. Brushes not properly fitted to the commutator. Use sandpaper, brush jig or brush seater stone to fit or seat brushes.

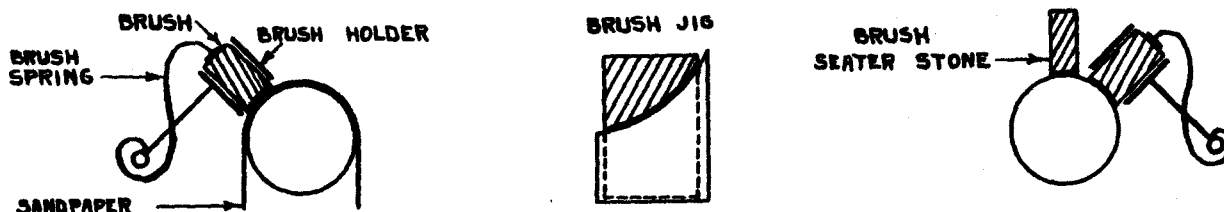

7. Brushes off neutral position. This condition will cause brush sparking and cause a motor to operate at a speed higher than name plate speed. The correct position can be located by using one of the following methods. 1. If the machine is operating with load shift the brushes to a position of sparkless commutation. 2. Connect a voltmeter across the brushes of a motor and the shunt field circuit. The brush position giving the lowest voltmeter reading will be the correct position. The motor must not rotate while the test is being made. For a generator the brush position giving the highest voltage will be the correct position. The generator should be operating without load when the test is made.

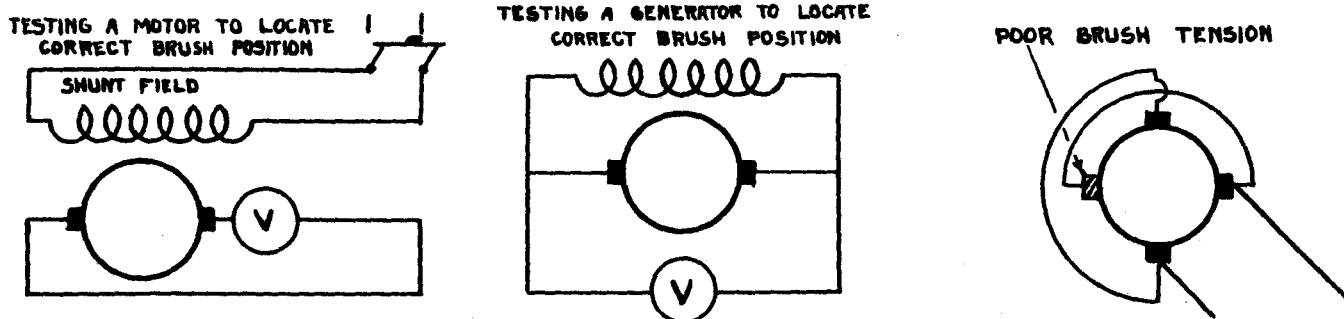

8. Poor or unequal brush tension. Apply equal tension of 1 to 3 lbs. per square inch of brush surface on the commutator. Measure brush tension by using a small spring scale.

9. High mica. Use hack saw blade or undercutting machine and undercut the mica about $1/16$ inch.

10. Wet or oily windings. All damaged windings must be properly cleaned and repaired before drying. Use carbon tetra chloride or other agents for cleaning. Dry windings by baking at 180 F. until dry. Motors can be dried out by operating them with an ammeter and a regulating resistor connected in series with the machine windings. Adjust the regulating resistor so the current through the chine windings will not exceed name plate value. After machine has been dried out make an insulation test to determine the condition of the insulation.

11. Rough or dirty commutator. Smooth commutator with sandpaper or commutator stone. True commutator by turning it in a lathe or using tools made for that purpose. After trueing a commutator in a lathe use #000 or #0000 sandpaper to smooth commutator. Clean commutator with fine sandpaper or use a cleaning agent such as carbon tetra chloride. It is best not to use a cutting agent for cleaning. Never use emery cloth or a lubricant of any kind on a commutator.

12. Incorrect grade of carbon brush. Carbon brushes vary in capacity from 40 I to 125 I per square inch of brush surface in the commutator. When renewing brushes always be certain that the brush used has sufficient capacity to carry the load without overheating.

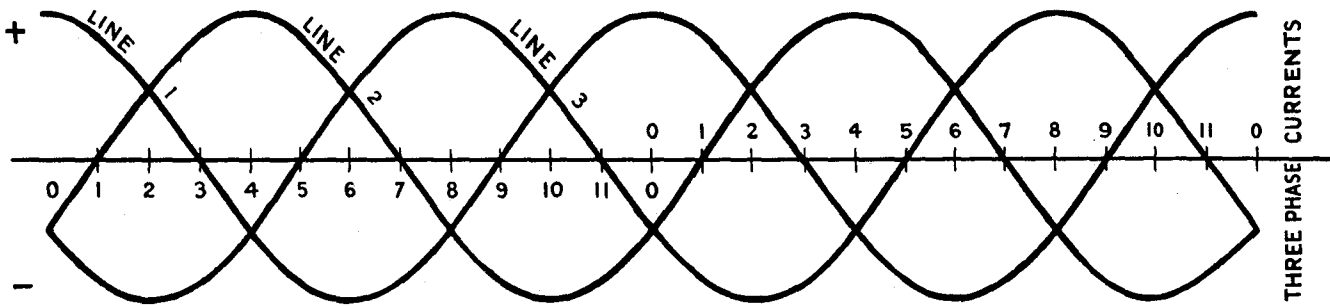
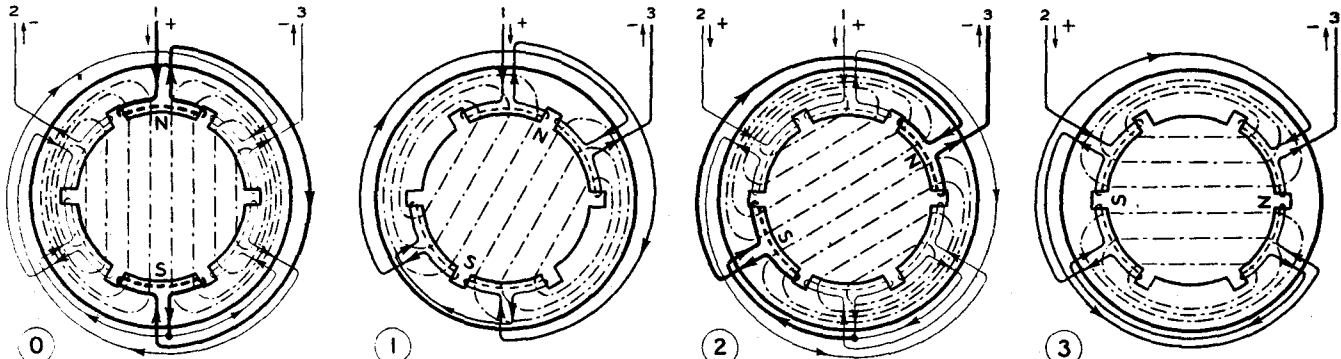

Fig. 60. This diagram of three-phase voltages covers two complete cycles. The numbers on it refer to the numbers on the diagrams below. Each diagram shows the condition in the armature at the instant indicated by the corresponding number on this curve. The action of the magnetic field is smooth and regular; the rise and fall of currents in the conductors is also smooth and regular



0 The current entering the motor on line 1 divides equally and leaves the motor on line 2 and line 3

1 Now the current in line 2 is zero and that flowing in at line 1 leaves at line 3. The magnetic field revolves clockwise

2 The current in line 1 is small and joining that from line 2 flows out in line 3 which carries a maximum negative current

3 This and the following diagrams show how the magnetic field continues to rotate throughout the remainder of the cycle

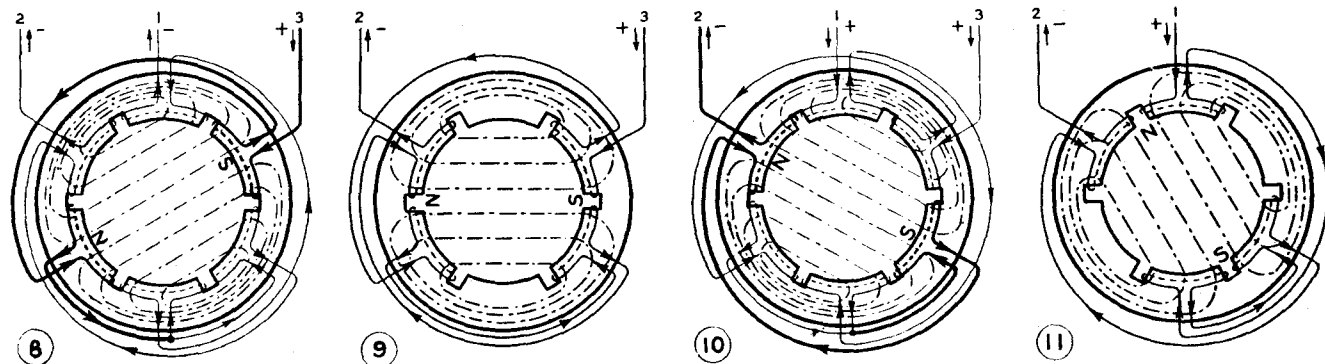
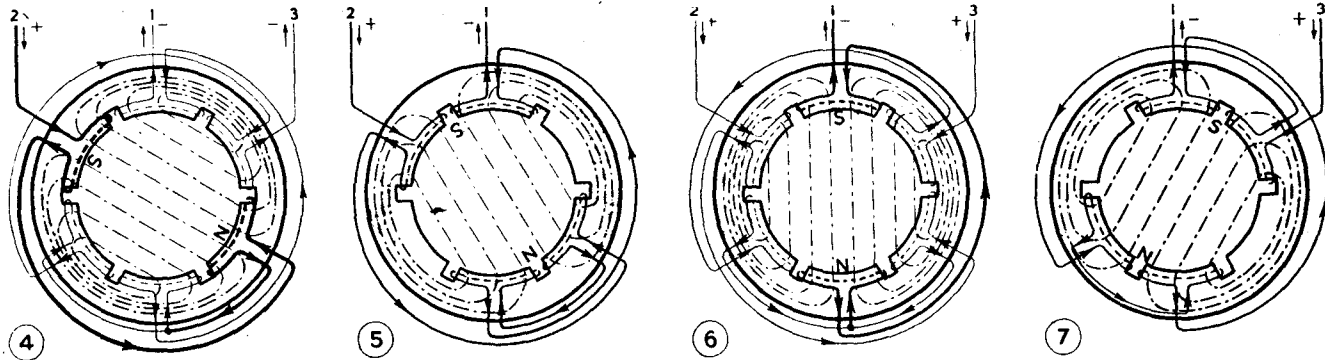

Fig. 61. This series of twelve diagrams shows the electric and magnetic conditions in a two-pole, three-phase motor at the end of twelve equal parts of one cycle

MOTOR CHARACTERISTICS

Type of Driven Machinery	Motor Type Designation	Speed R.P.M.	Approx. Starting Torque in % of Full Load Torque	Approx. Maximum Torque in % of Full Load Torque	Approx. Starting Current in % of Full Load Current	Approx. Speed Regulation % Slip	Starting Equipment	Load Conditions
Pumps (Centrifugal, Rotary and Turbine); Cotton Gins; Fans (Centrifugal and Propeller); Line Shafts; Motor Generator Sets; Shapers; Screw Machines; Planers; Milling Machines; Keyseating Machines; Lathes; Buffers; Drill Presses; Metal Grinders; Joiners; Molders; Sanders; Circular Saws (Small and Medium); Positive Pressure Blowers; Job Printing Presses; Brine Agitators; Pulp Grinders; Jordans; Laundry Washers; Small Stokers.	Type QZK	1800	125 To 180	200 To 250	450 To 550	2 To 4	Type QZK motors may be started across the line at full voltage with comparative low starting current. Starters may be reduced voltage or full voltage types. Manual or magnetic, non-reversing or reversing.	Require normal starting torque for continuous duty. Infrequent load fluctuations. Motor provides service factor for overload conditions. Constant speed. No special conditions.
		1200	125 To 180	200 To 250	450 To 550	2 To 4		
		900	115 To 140	200 To 225	450 To 550	2 To 4		
Pumps (Reciprocating and Displacement); Air Compressors; Refrigerating Compressors; Conveyors; Stokers; Crushers (without flywheels); Dough Mixers; Grinders; Hammer Mills; Ball Mills; Turn Tables; Car Fullers; Large Band Saws; Bug Mills; Dry Pans; Brick Presses; Gear Plungers; Brick and Tile Machines; Foundry Tumbling Barrels; Centrifugal Sand Mixers; Grain Elevator Legs; Bending and Straightening Rolls; Bucket-type Elevators; Conveyors starting loaded.	Type QOZK Ratings 3 H.P. & Larger	1800	225 To 275	200 To 250	450 To 550	3 To 5	Across the line, full-voltage manual or magnetic, non-reversing or reversing.	Compressors and pumps requiring less than 7½ Hp. under certain conditions may be successfully handled by type QZK Motors. Heavy starting, continuous or intermittent duty; service factor for overload conditions.
		1200	200 To 250	200 To 225	450 To 550	3 To 5		
		900	190 To 225	190 To 200	450 To 550	3 To 5		
Passenger and Freight Elevators.	Type QRZK	1800	300-400	300-400	300-350	15-20	Across the line, full-voltage reversing elevator control with master switches or drives.	Require high starting torque intermittent duty single speed reversing service.
		1200	300-400	300-400	300-350	15-20		
Hoists, Lifts, Small Cranes, Valves.	Type QLZK	1800	300-400	300-400	325-375	15-20	Same as for Type QRZK.	Intermittent duty single speed reversing.
		1200	300-400	300-400	325-375	15-20		
Punch Presses, Laundry Extractor, Shears, Power Hammers, Crushers with Flywheels, Bending Rolls with Flywheels.	Type QFZK	1800	300-350	300-350	375-450	Range 5-8 8-13	Across the line, full-voltage, manual or automatic reversing or non-reversing.	High starting torque. Heavy fluctuating loads, usually with flywheels or high inertia to accelerate; continuous duty.
		1200	300-350	300-350	375-450			
		900	300-350	300-350	375-450			
Pumps, Centrifugal and Turbine Blowers and Fans, Centrifugal and Propeller.	Type QBZK 40 H.P. & Larger	1800	75-100	150-160	350-400	3-5	Across the line, full-voltage, manual or automatic reversing or non-reversing.	Low starting and maximum torque. Low starting current. Continuous duty, service factor 1.0 and no overload capacity.
		1200	75-100	150-160	350-400	3-5		
		900	75-100	150-160	350-400	3-5		
Compressors; Conveyors; Elevators; Grinding Machinery; Hoists; Laundry Machinery; Machine Tools; Mills; Mixing Machines; Positive Displacement Blowers; Positive Displacement Pumps; Printing Presses; Pulverizing Machines; Woodworking Machines.	QXZK Multi-Speed Constant Torque	1800/900	125-180	200-250	450-550	2-4	Type QXZK motors may be started across the line at full voltage with comparative low starting current. Starters may be reduced voltage or full voltage types. Manual or magnetic, non-reversing or reversing.	Require normal starting torque for continuous duty. Infrequent load fluctuations. Motor provides service factor for overload conditions. Constant speed. No special conditions.
		1800/1200/900/600	125-180	200-250	450-550	2-4		
Machine Tools; Production Equipment; Punch Presses; Winches, Bending Rolls, etc.	QMZK Multi-Speed Constant Horsepower	1800/900	125-180	200-250	450-550	2-4	Type QMZK motors may be started across the line at full voltage with comparative low starting current. Starters may be reduced voltage or full voltage types. Manual or magnetic, non-reversing or reversing.	Require normal starting torque for continuous duty. Infrequent load fluctuations. Motor provides service factor for overload conditions. Constant speed. No special conditions.
		1800/1200/900/600	125-180	200-250	450-550	2-4		
Blowers, Fans and Pumps.	QNZK Multi-Speed Variable Torque	1800/900	125-180	200-250	450-550	2-4	Type QNZK motors may be started across the line at full voltage with comparative low starting current. Starters may be reduced voltage or full voltage types. Manual or magnetic, non-reversing or reversing.	Require normal starting torque for continuous duty. Infrequent load fluctuations. Motor provides service factor overload conditions. Constant speed. No special conditions.
		1800/1200/900/600	125-180	200-250	450-550	2-4		

SPEED CLASSIFICATION	POWER SUPPLY	N.E.M.A. CLASS.	L.A. TYPE	TYPE OF MOTOR	* RANGE OF HORSEPOWER RATINGS	STARTING TORQUE PER CENT OF FULL LOAD	MAXIMUM TORQUE PER CENT OF FULL LOAD	SPEED REGULATION PER CENT SLIP	GENERAL REMARKS	AGITATORS - MIXERS	BALL - ROD - PUG MILLS	BALING PRESSES	BENDING ROLLS	BLOWERS - POSITIVE PR.	BORING MILLS	BUCKET ELEVATORS	
CONSTANT SPEED	ALTERNATING CURRENT 3 & 2 PHASE	A	S	STANDARD SQUIRREL CAGE NORMAL TORQUE - NORMAL STARTING CURRENT	1/2 TO 300 HP.	150	200 TO 250	2 TO 5	GENERAL PURPOSE WIDE APPLICATION	⊙				⊙	⊙		
		B	X	SQUIRREL CAGE NORMAL TORQUE - LOW STARTING CURRENT	7/2 TO 200 HP.	125 TO 150	200 TO 225	2 TO 5	SIMPLE CONTROL	⊙					⊙	⊙	
		C	A	SQUIRREL CAGE HIGH TORQUE - LOW STARTING CURRENT	3 TO 100 HP.	200 TO 250	175 TO 225	4 TO 5	HEAVY STARTING SIMPLE CONTROL		⊙						⊙
		D	K	SQUIRREL CAGE HIGH TORQUE - HIGH SLIP	1/2 TO 100 HP.	200 TO 300	200 TO 300	8 TO 15	HEAVY STARTING - INTERMITTENT AND FLUCTUATING LOAD		⊙	⊙	⊙				⊙
		F	W	SQUIRREL CAGE LOW TORQUE - LOW STARTING CURRENT	40 TO 100 HP.	50 TO 80	125 TO 150	4 TO 5	SPECIAL PURPOSE CONSTANT LOAD LIGHT STARTING						⊙		
		-	WX	SQUIRREL CAGE LOW TORQUE	1/2 TO 10 HP.	100 TO 125	175 TO 200	4 TO 5	SPECIAL SERVICE SMOOTH REVERSAL								
	-	H	WOUND ROTOR	1/2 TO 300 HP.	200 TO 250	200 TO 250	*	FREQUENT & HEAVY STARTING		⊙		⊙				⊙	
	-	C	CAPACITOR - INDUCTION LOW TORQUE	1/2 TO 10 HP.	50 TO 75	175 TO 200	4 TO 6	LIGHT STARTING DIRECT CONN. LOAD									
	-	CN CU	CAPACITOR - INDUCTION NORMAL TORQUE	1/2 TO 10 HP.	150 TO 200	175 TO 200	4 TO 6	GENERAL PURPOSE INFREQUENT STARTING	⊙						⊙		
	-	NA	SHUNT WOUND	1/2 TO 75 HP.	150	/	5 TO 10	GENERAL PURPOSE STEADY LOADS	⊙						⊙	⊙	
	-	NA	COMPOUND WOUND	1/2 TO 75 HP.	175 TO 200	/	10 TO 25	HEAVY STARTING FLUCTUATING LOAD		⊙	⊙					⊙	
	-	NA	SERIES WOUND	1/2 TO 75 HP.	300 TO 400	/	*	HEAVY AND FREQUENT STARTING					⊙				
ADJUSTABLE SPEED	A.C. 3 & 2 PHASE	-	M	CONSTANT HORSEPOWER 2 - 3 - 4 SPEEDS	1/4 TO 150 HP.	125 TO 150	175 TO 200	4 TO 6	SPEED INDEPENDENT OF LOAD							⊙	
		-	M	CONSTANT TORQUE 2 - 3 - 4 SPEEDS	1/4 TO 200 HP.	125 TO 150	175 TO 200	4 TO 6	SPEED INDEPENDENT OF LOAD	⊙	⊙			⊙		⊙	
		-	M	VARIABLE TORQUE 2 - 3 - 4 SPEEDS	1/4 TO 200 HP.	125 TO 150	175 TO 200	4 TO 6	SPEED INDEPENDENT OF LOAD								
	-	NW	FIELD CONTROL	1/4 TO 50 HP.	150	/	5 TO 10	WIDE RANGE FLEXIBLE CONTROL								⊙	
	-	NA	VARIABLE VOLTAGE CONTROL	1/4 TO 30 HP.	150	/	*	EXTREME WIDE RANGE FLEXIBLE CONTROL									
	-	H	WOUND ROTOR	1/2 TO 300 HP.	200 TO 250	200 TO 250	*	LIMITED RANGE HEAVY STARTING	⊙	⊙		⊙	⊙			⊙	
VARIABLE SPEED	DIRECT CURRENT SHUNT	-	NA	ARMATURE CONTROL	1/2 TO 75 HP.	150	/	*	LIMITED RANGE DEPENDENT ON LOAD	⊙					⊙		
		-	NA	FIELD AND ARMATURE CONTROL	1/2 TO 50 HP.	150	/	*	WIDE RANGE LIMITED APPLICATION								
		-	NA	VARIABLE VOLTAGE CONTROL	1/4 TO 30 HP.	150	/	*	WIDE RANGE LOW EFFICIENCY								
	DIRECT CURRENT COMPOUND	-	NA	ARMATURE CONTROL	1/2 TO 75 HP.	175 TO 200	/	*	LIMITED RANGE DEPENDENT ON LOAD		⊙						⊙
		-	NA	FIELD AND ARMATURE CONTROL	1/2 TO 50 HP.	175 TO 200	/	*	WIDE RANGE LIMITED APPLICATION								
		-	NA	VARIABLE VOLTAGE CONTROL	1/4 TO 30 HP.	175 TO 200	/	*	WIDE RANGE LOW EFFICIENCY								
		-	NA	ARMATURE CONTROL	1/2 TO 75 HP.	300 TO 400	/	*	LIMITED RANGE HEAVY STARTING						⊙		

* DEPENDENT UPON LOAD AT NORMAL SPEED.

** HORSEPOWER RATINGS, TORQUE AND REGULATION DATA IS FOR 4 POLE (1800 R.P.M.) 60 CYCLE A.C. MOTO

/ MAXIMUM TORQUE IS LIMITED BY COMMUTATION. UNDER NORMAL CONDITIONS D.C. MOTOR DEVELOPS 200 T

D. C. GENERATORS.

GENERATOR ACTION

An electrical generator is a device designed to change mechanical energy into electrical energy. Note that it does not generate energy, it merely converts it from the mechanical to the electrical form.

As no conversion device is 100% efficient, the power input to the generator must be greater than the rated generator output. For generators of 5 K W rating or above, a prime mover capable of supplying 1.5 H P for each K W of generator output is usually employed.

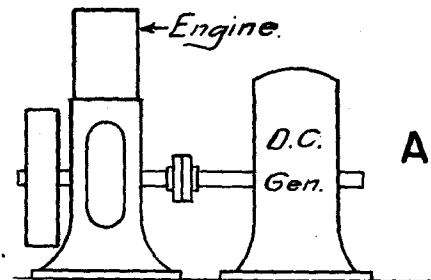

SEPARATELY EXCITED GENERATORS

The D. C. Generator produces voltage by rotating conductors through a magnetic field. In Figure B this field is produced by field coils that are energized from a separate source external to the machine. This type of generator may be driven in either direction, for the field excitation is independent. The polarity of the brushes will reverse when the rotation is changed, the positive brush becoming negative and vice versa.

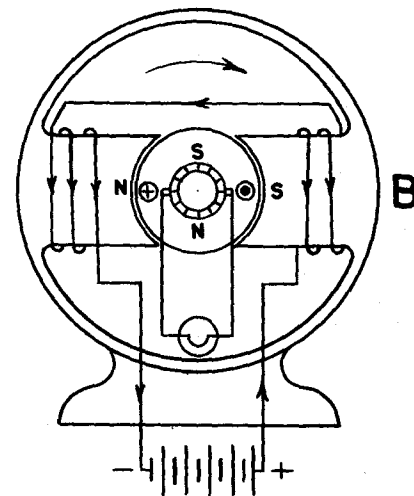

SELF EXCITED GENERATOR SHUNT TYPE

In this machine, the energy for the field is obtained from the armature and the generator is self exciting. The field poles retain some magnetism after having once been magnetized, and as the armature is rotated, the conductors cut this residual flux and generate voltage. This voltage is applied to the field, which is in parallel with the armature, and in this manner the field is strengthened. This increased field raises the voltage still further and this action continues until normal voltage is reached. The magnetic polarity set up by the field coils must be the same as the residual magnetism, otherwise the voltage will not build up.

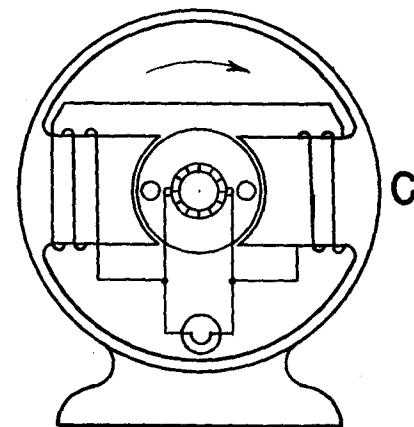

FAILURE TO GENERATE

The self excited type generator may fail to develop normal voltage due to: no residual field magnetism; magnetic effect of field coils opposing residual magnetism; poor brush contact; speed too low; wrong direction of rotation.

When the direction of rotation is changed, the brush polarity reverses and this reverses the current flow through the field coils, causing the coil magnetism to weaken the residual field. Under such conditions, the generator cannot build up a voltage. For operation in the opposite direction, the field leads must be reversed.

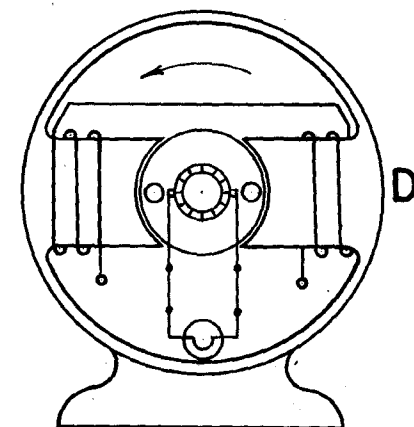

VARIABLE VOLTAGE CONTROL.

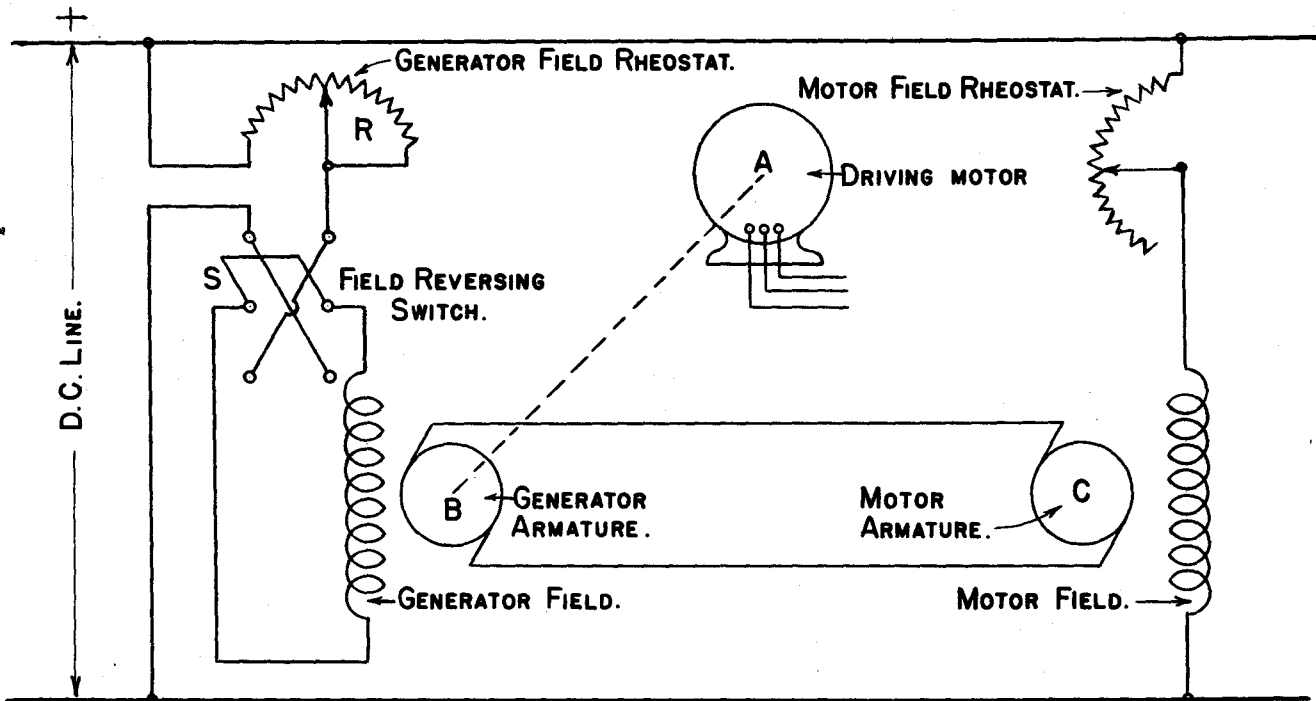

The variation in speed obtainable by field control on the ordinary D.C. motor will not, in the average case, exceed 4 to 1 due to the sparking difficulties experienced with very weak fields. Although the range may be increased by inserting resistance in series with the armature, this can be done only at the expense of efficiency and speed regulation.

With constant voltage applied to the field, the speed of a D.C. motor varies directly with the armature voltage; therefore, such a motor may be steplessly varied from zero to maximum operating speed by increasing the voltage applied to its armature. The sketch shows the arrangement of machines and the connections used in the Ward Leonard type of variable voltage control designed to change speed and reverse rotation. The constant speed D.C. generator (B) is usually driven by an A.C. motor (A) and its voltage is controlled by means of rheostat R. Note that the fields of both generator (B) and driving motor (C) are energized from a separate D.C.

supply or by an auxiliary exciter driven off the generator shaft. Thus the strength of the motor field is held constant, while the generator field may be varied widely by rheostat R.

With the set in operation generator (B) is driven at a constant speed by prime mover A. Voltage from B is applied to the D.C. motor (C) which is connected to the machine to be driven. By proper manipulation of rheostat R and field reversing switch S the D.C. motor may be gradually started, brought up to and held at any speed, or reversed. As all of these changes may be accomplished without breaking lines to the main motor, the control mechanism is small, relatively inexpensive, and less likely to give trouble than the equipments designed for heavier currents.

The advantages of this system lie in the flexibility of the control, the complete elimination of resistor losses, the relatively great range over which the speed can be varied, the excellent speed regulation on each setting, and the fact

that changing the armature voltage does not diminish the maximum torque which the motor is capable of exerting since the field flux is constant.

By means of the arrangement shown, speed ranges of 20 to 1—as compared to 4 to 1 for shunt field control—may be secured. Speeds above the rated normal full load speed may be obtained by inserting resistance in the motor shunt field. This represents a modification of the variable voltage control method which was originally designed for the operation of constant torque loads up to the rated normal full load speed.

As three machines are usually required, this type of speed control finds application only where great variations in speed and unusually smooth control are desired. Steel mill rolls, electric shovels, passenger elevators, machine tools, turntables, large ventilating fans and similar equipments represent the type of machinery to which this method of speed control has been applied.

PARALLELING D.C. GENERATORS.

POSITIVE BUS BAR

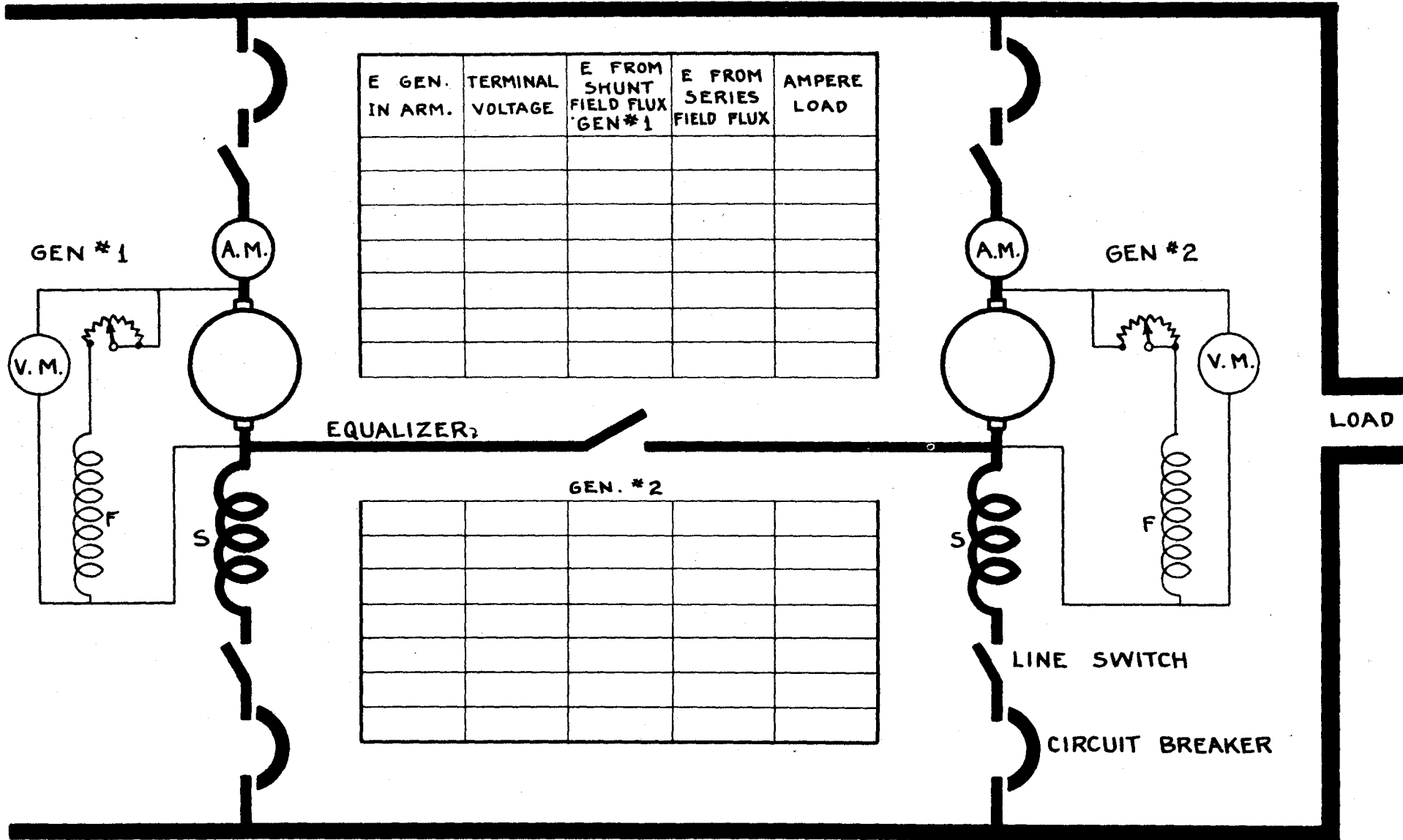

E GEN. IN ARM.	TERMINAL VOLTAGE	E FROM SHUNT FIELD FLUX GEN #1	E FROM SERIES FIELD FLUX	AMPERE LOAD

GEN. #2

NEGATIVE BUS BAR

SERIES WELDING GENERATOR

CROSS FIELD DESIGN

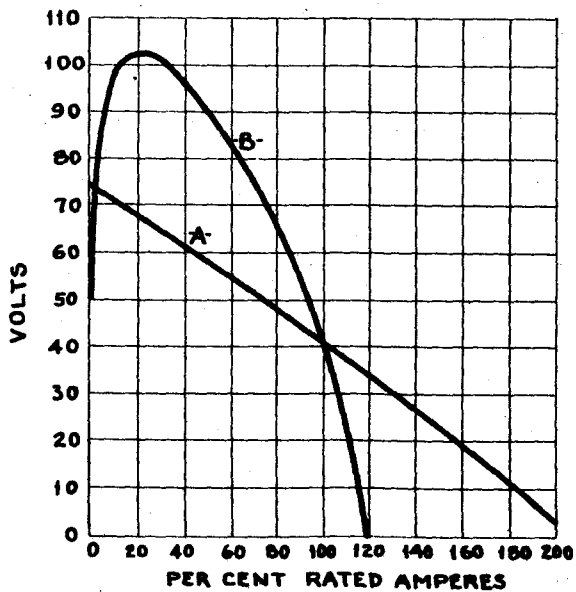
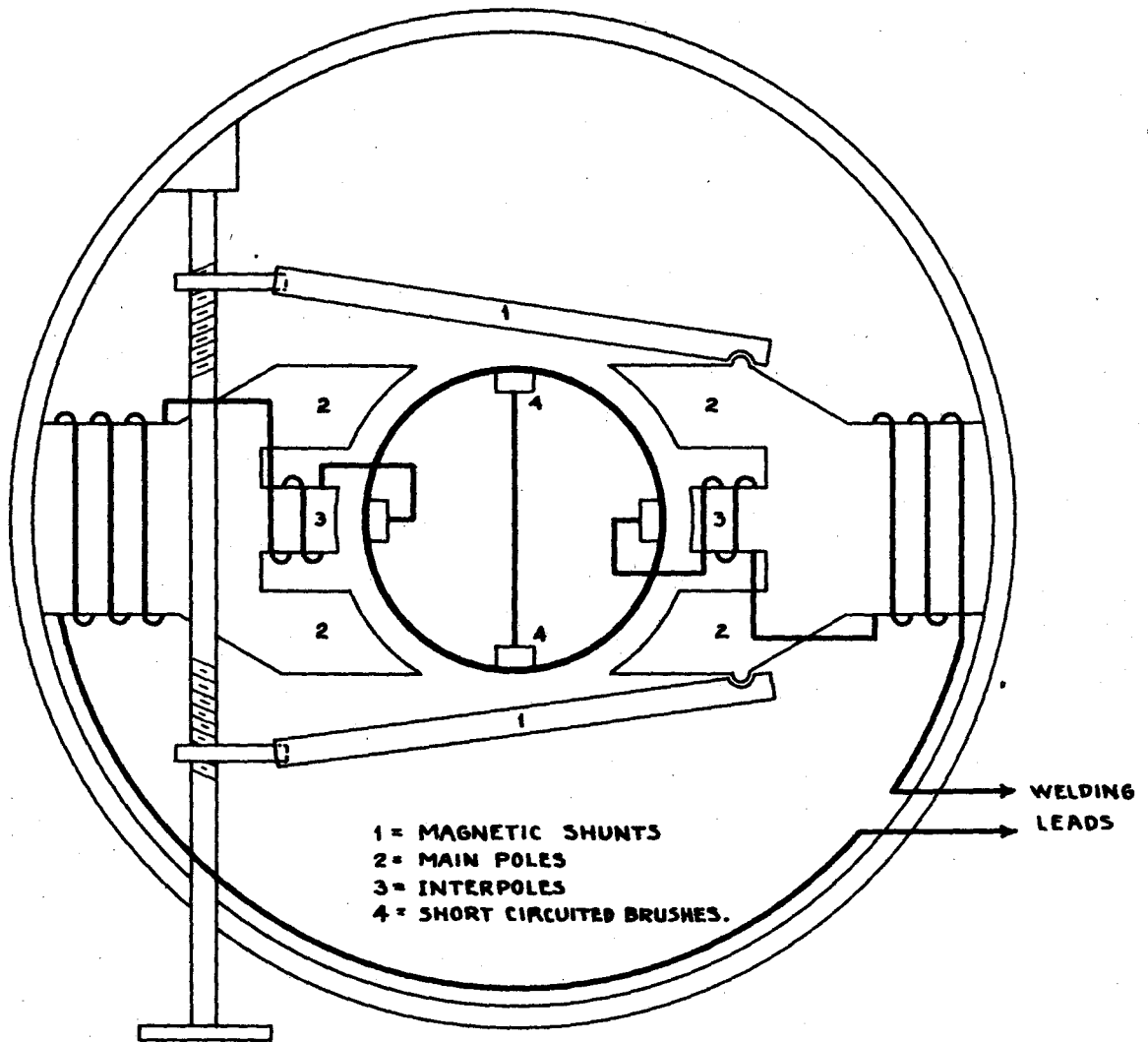

THIS WELDER ELIMINATES THE USE OF A REACTOR, EXCITER, VOLTMETER, AMMETER, METER SWITCHES, FIELD RHEOSTATS, AND FIELD DISCHARGE RESISTANCE. HOWEVER IT OPERATES VERY SATISFACTORILY HAVING FEWER PARTS THAN OTHER TYPES OF WELDING GENERATORS. THE MAINTENANCE COST IS CONSIDERABLY LOWER.

THE VOLT-AMPERE CURVE -A- IS A COMPOSITE, AND THE CURVE AT -B- IS THAT OF ONE OF THE CROSS FIELD WELDING GENERATORS.

VARIABLE VOLTAGE CONTROL.

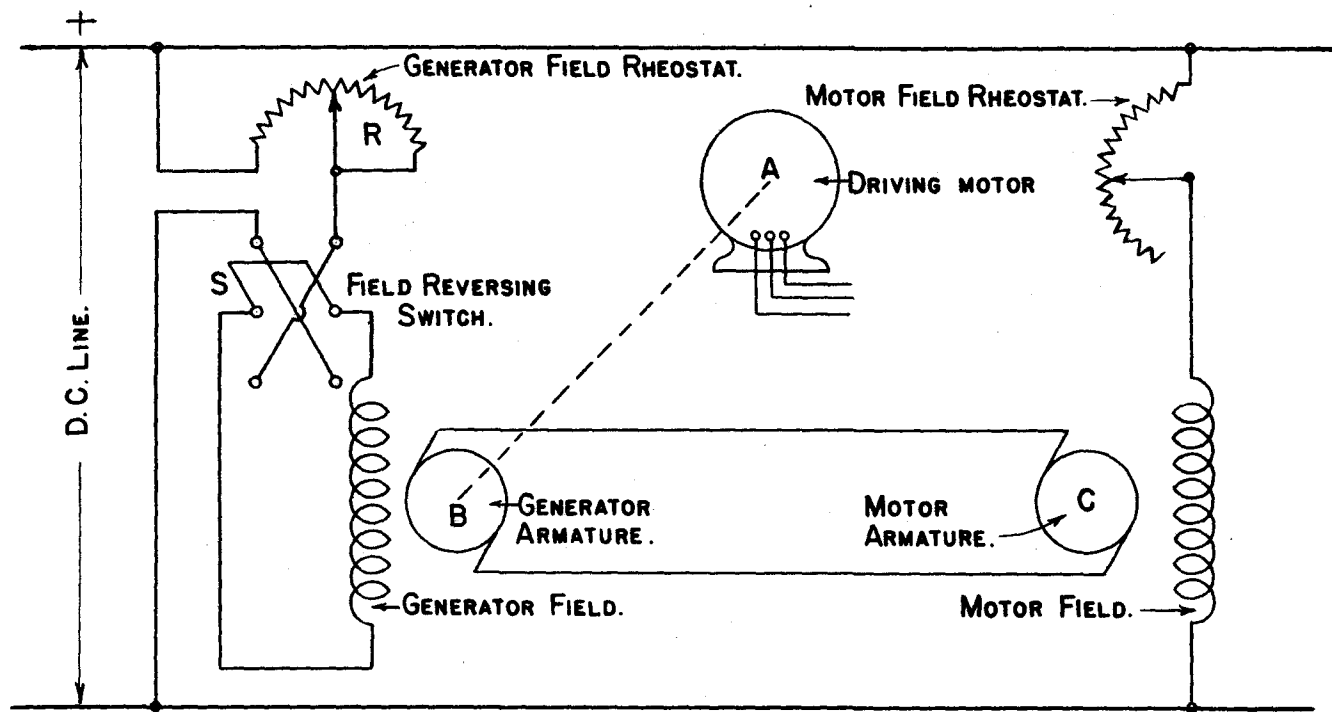

The variation in speed obtainable by field control on the ordinary D.C. motor will not, in the average case, exceed 4 to 1 due to the sparking difficulties experienced with very weak fields. Although the range may be increased by inserting resistance in series with the armature, this can be done only at the expense of efficiency and speed regulation.

With constant voltage applied to the field, the speed of a D.C. motor varies directly with the armature voltage; therefore, such a motor may be steplessly varied from zero to maximum operating speed by increasing the voltage applied to its armature. The sketch shows the arrangement of machines and the connections used in the Ward Leonard type of variable voltage control designed to change speed and reverse rotation. The constant speed D.C. generator (B) is usually driven by an A.C. motor (A) and its voltage is controlled by means of rheostat R. Note that the fields of both generator (B) and driving motor (C) are energized from a separate D.C.

supply or by an auxiliary exciter driven off the generator shaft. Thus the strength of the motor field is held constant, while the generator field may be varied widely by rheostat R.

With the set in operation generator (B) is driven at a constant speed by prime mover A. Voltage from B is applied to the D.C. motor (C) which is connected to the machine to be driven. By proper manipulation of rheostat R and field reversing switch S the D.C. motor may be gradually started, brought up to and held at any speed, or reversed. As all of these changes may be accomplished without breaking lines to the main motor, the control mechanism is small, relatively inexpensive, and less likely to give trouble than the equipments designed for heavier currents.

The advantages of this system lie in the flexibility of the control, the complete elimination of resistor losses, the relatively great range over which the speed can be varied, the excellent speed regulation on each setting, and the fact

that changing the armature voltage does not diminish the maximum torque which the motor is capable of exerting since the field flux is constant.

By means of the arrangement shown, speed ranges of 20 to 1—as compared to 4 to 1 for shunt field control—may be secured. Speeds above the rated normal full load speed may be obtained by inserting resistance in the motor shunt field. This represents a modification of the variable voltage control method which was originally designed for the operation of constant torque loads up to the rated normal full load speed.

As three machines are usually required, this type of speed control finds application only where great variations in speed and unusually smooth control are desired. Steel mill rolls, electric shovels, passenger elevators, machine tools, turntables, large ventilating fans and similar equipments represent the type of machinery to which this method of speed control has been applied.

REVISIONS	MATERIAL	PAT. MLD. DIE	V-5835197
DRAWN BY <i>J. Edrell</i>		EXTERNAL DIAGRAM	
INSPECTED <i>W. H. Hens</i>		FIRST MADE FOR <i>BC GENERATOR</i>	
FIRST CALLED FOR ON <i>CPRW-740834-89</i>			

THIRD ANGLE PROJECTION

V

PRINTS TO

86

8442

B 15

357

3742

GENERAL ELECTRIC FORT WAYNE WORKS

V-5835197

F. O. Im B-10-37

REVISIONS	MATERIAL	PAT. MLD. DIE	V-5837239
DRAWN BY <i>J. Edrell</i>		EXTERNAL DIAGRAM	
INSPECTED <i>W. H. Hens</i>		FIRST MADE FOR <i>DC MOTORS - (CUMULATIVE COMPOUND GEN.)</i>	
FIRST CALLED FOR ON <i>STL-84280</i>			

THIRD ANGLE PROJECTION

V

PRINTS TO

B 3

B 442

B 45

B 57

B 142

GENERAL ELECTRIC FORT WAYNE WORKS

V-5837239

F. O. Im 12-22-37

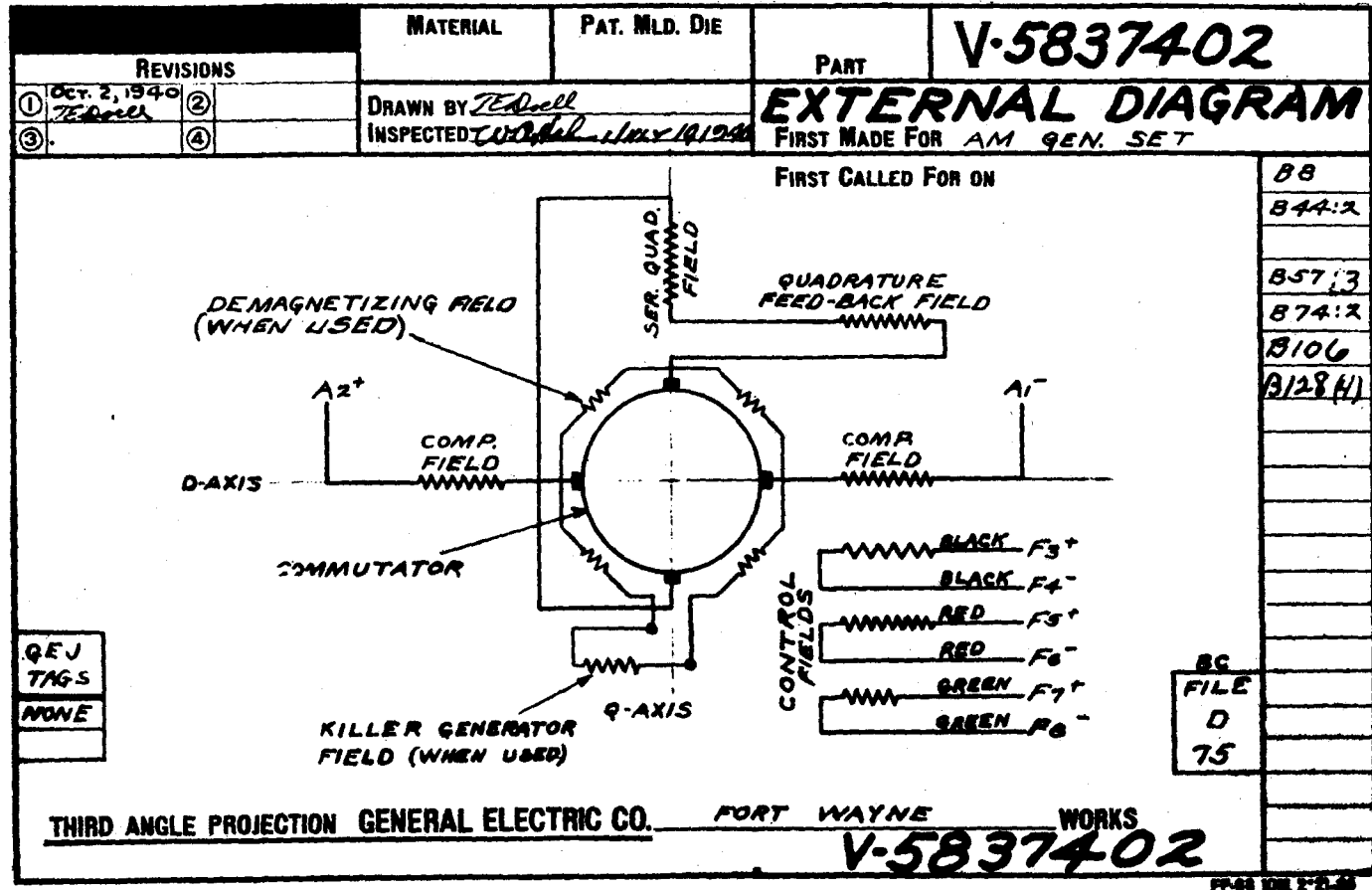
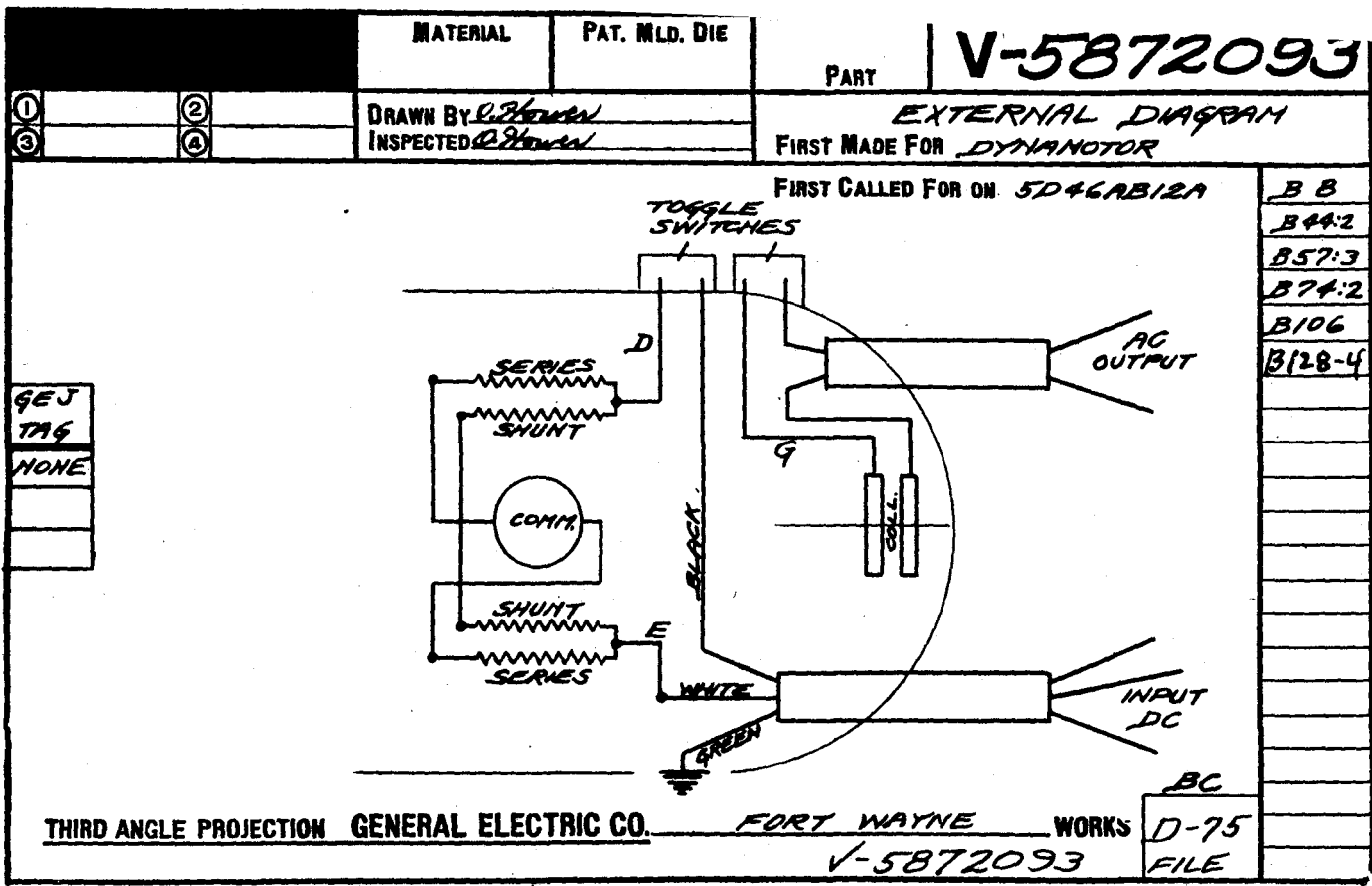

LAP WINDING AND ARMATURE CONNECTIONS

An armature winding is an electro-magnet having a number of coils connected to commutator bars. There must be at least one start and one finish lead connected to each commutator bar. There are two types of armature windings, LAP & WAVE wound. The coil leads of a lap wound armature connects to commutator bars that are near each other and the coil leads of a wave wound armature connects to commutator bars that are widely separated. See Fig. 1 & 2.

When current flows through the coil in a clockwise direction a south pole will be produced on the surface of the armature. Fig. 3. If the current flows in a counter clockwise direction a north pole will be produced on the surface of the armature. Fig. 4. A large number of coils are used to produce a strong magnetic pole and a smoother twisting action.

FIG. 1

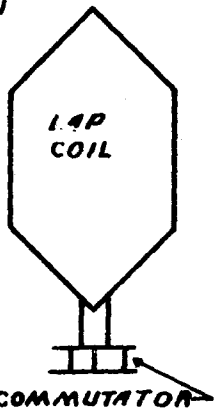

FIG. 2

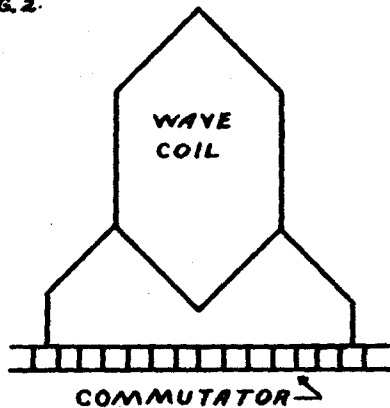

FIG. 3

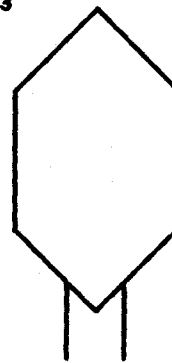
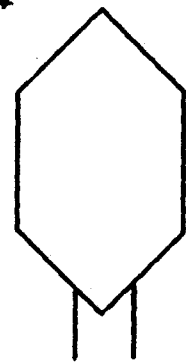

FIG. 4



ARMATURE WINDING CONNECTIONS

Although there are only two types of D.C. armature windings there are a number of winding connections that apply to either a lap or a wave wound armature.

SYMMETRICAL & NON-SYMMETRICAL CONNECTIONS. If the coil leads connect to commutator bars that are on a line with the center of the coil the connection is symmetrical. Fig. 5. If the coil leads connect to commutator bars that are not on a line with the center of the coil the connection is non-symmetrical. Fig. 6.

The brushes must always short the coil when it is in the neutral plane which means that the brushes be located on a line with the center of the field pole if the coil is connected symmetrical and located between the field poles if connected non-symmetrical.

FIG. 5

SYMMETRICAL

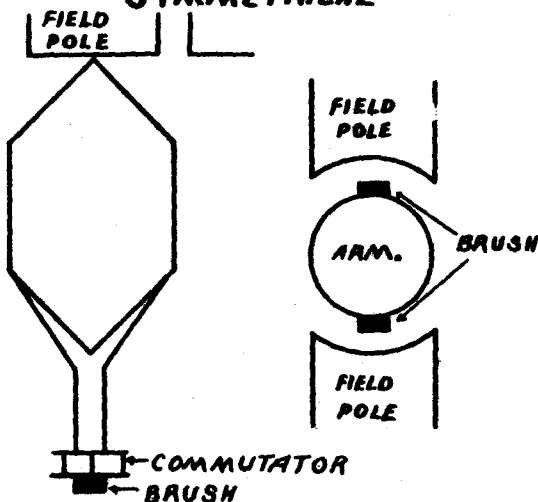
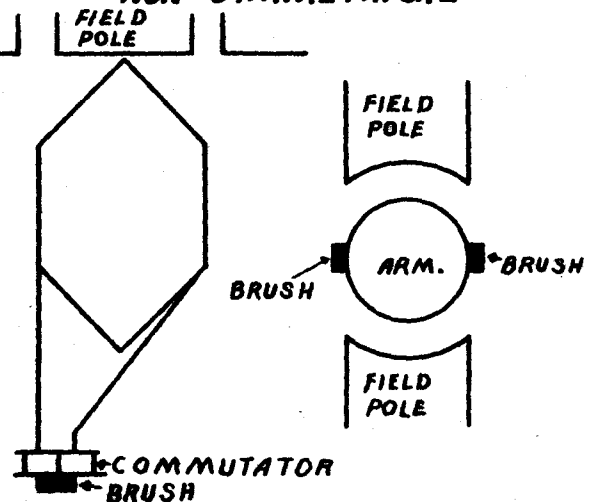

FIG. 6

NON-SYMMETRICAL



LAP WINDING AND ARMATURE CONNECTIONS (CONTINUED)

PROGRESSIVE & RETROGRESSIVE CONNECTIONS. If the start and finish leads of a coil, or the element of a coil, do not cross the connection is known as progressive. Fig. 7. If the start and finish leads of a coil, or the element of a coil, cross the winding is connected retrogressive. Fig. 8.

If a winding is changed from progressive to retrogressive, or vice versa, the effect will be reversed rotation on a motor and reversed brush polarity on a generator. Lap wound armatures are usually connected progressive and wave wound armatures retrogressive.

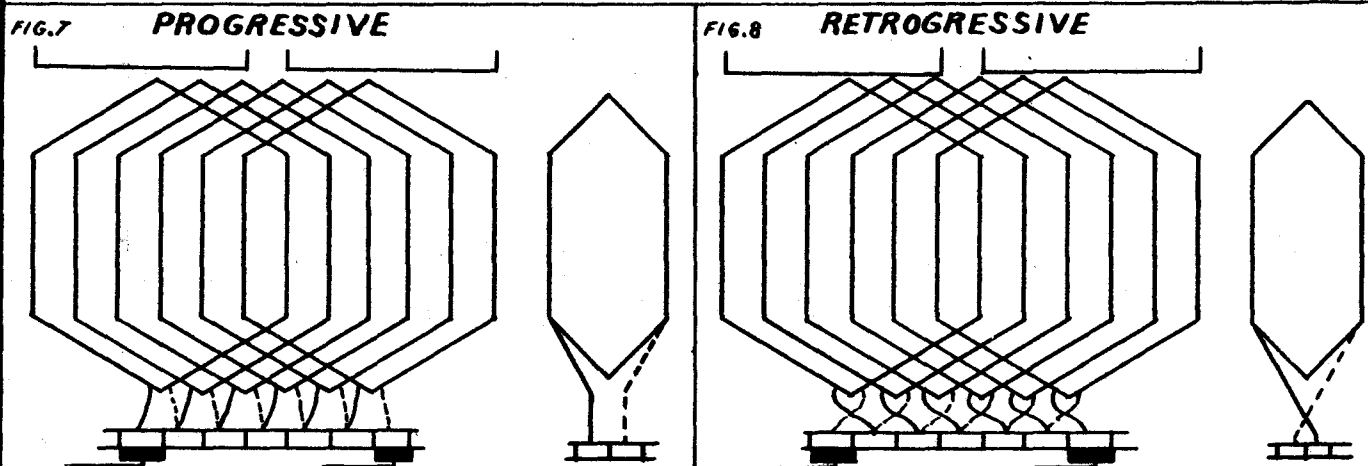

ELEMENT WINDINGS are used to reduce the voltage across adjacent commutator bars and decrease the tendency of brush sparking. Example - An armature has 30 turns per coil and the voltage per turn is 1 volt or 30 E per coil. If the coil were wound in one section and connected to adjacent commutator bars the voltage across the bars will be 30 E. Such a coil would have one start and one finish lead and there would be as many bars as slots. This would be a single element winding. Fig. 9.

If this coil were divided in two sections (15 turns per section) and each section connected to adjacent bars the voltage across adjacent bars would be 15 E. Such a coil would have two start and two finish leads and there would be twice as many bars as slots. This would be known as a two element winding. Fig. 10.

If the coil were divided in three sections (10 turns per section) and each section connected to adjacent bars the voltage across adjacent bars would be 10 E. Such a coil would have three start and three finish leads and there would be three times as many bars as slots. This would be known as a three element winding. Fig. 11.

Element windings are particularly desirable for high voltage machines. The practical limit is usually three or four elements.

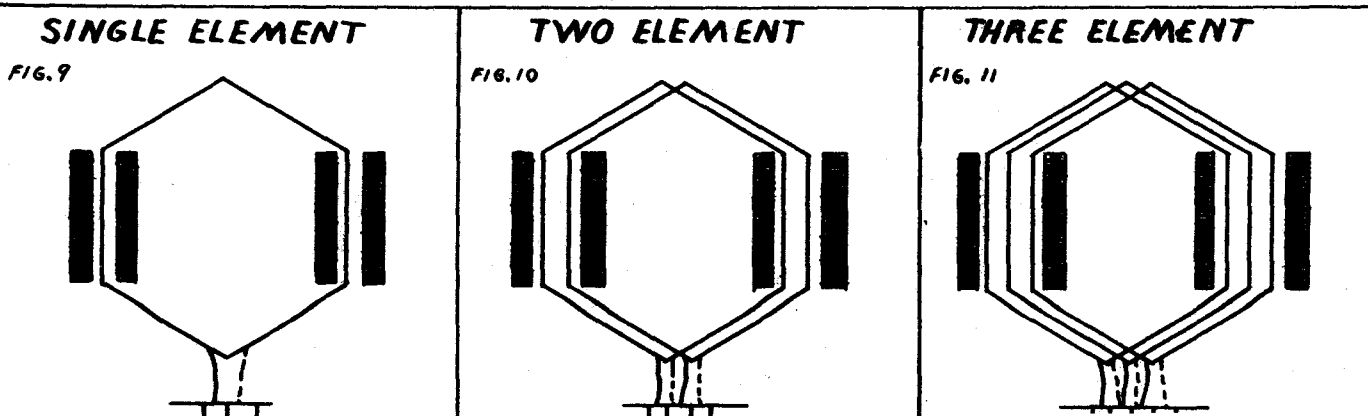

LAP WINDING
SIMPLEX
PROGRESSIVE
SYMMETRICAL
SINGLE ELEMENT

SLOTS = 24
BARS = 24
POLES = 4
COIL SPAN = 1-7

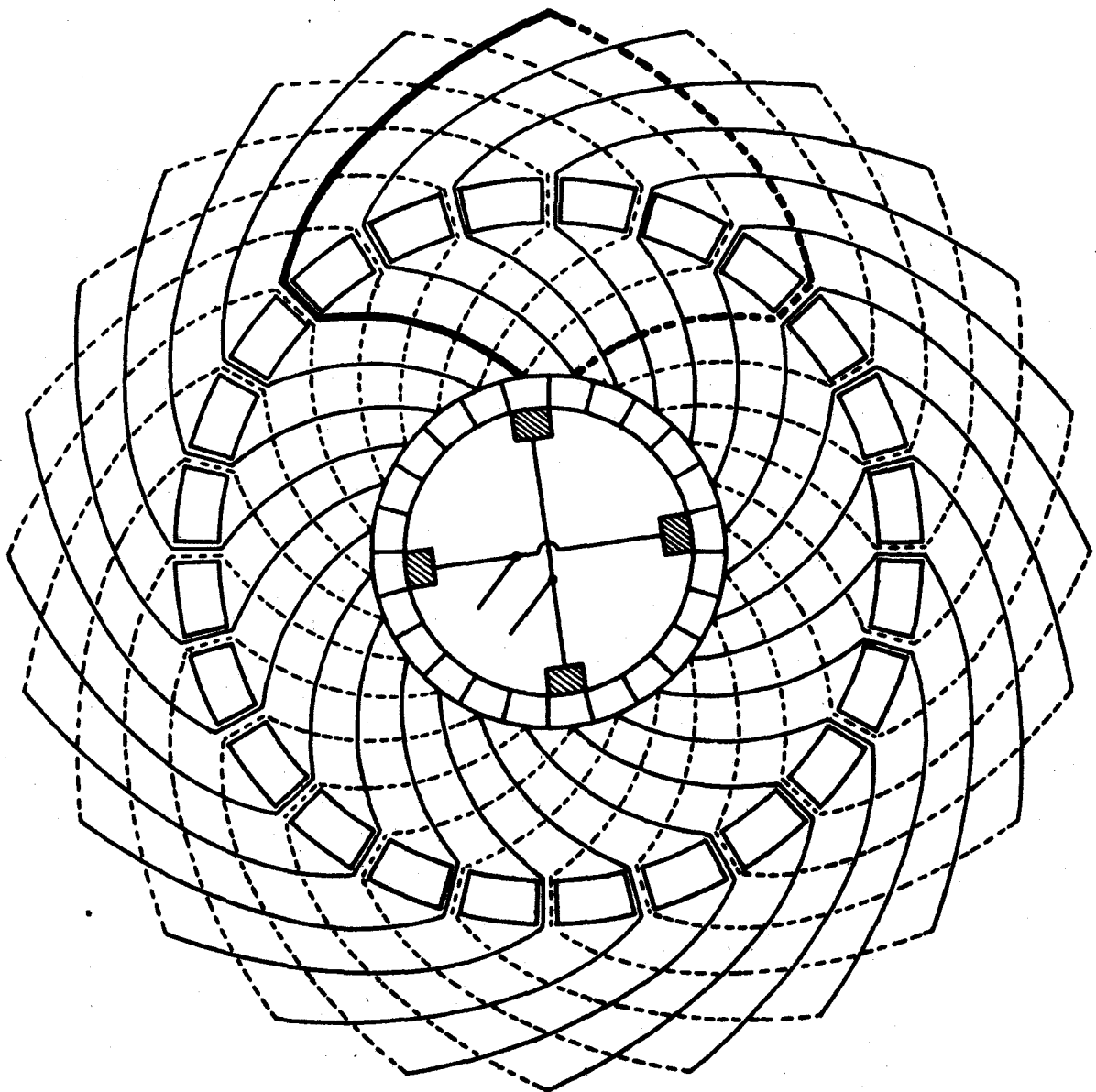

COIL SPAN = THE NEXT WHOLE NUMBER ABOVE $\frac{\text{SLOTS} + \text{POLES}}{2}$

LAP WINDING
SIMPLEX
PROGRESSIVE
NON-SYMMETRICAL
TWO ELEMENT

SLOTS = 15
BARS = 30
POLES = 2
COIL SPAN = 1-8

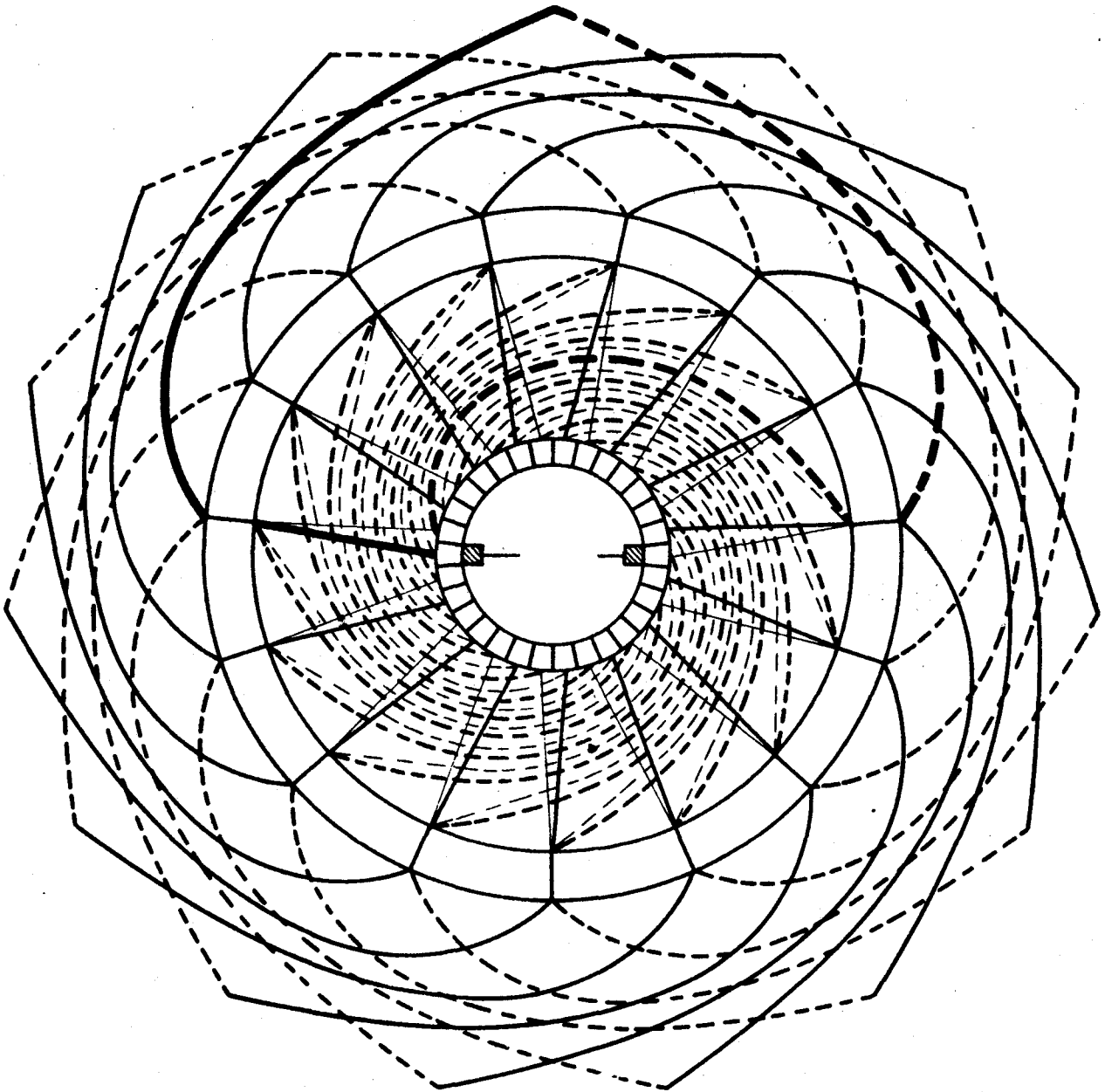

The lap winding is usually used on a circuit where the operating voltage is 220 E or less in value. This type of winding is desirable for general factory work. It is possible to design an armature for a higher ampere capacity by having it lap wound. The higher ampere capacity is obtained because there will be a greater number of parallel paths in the armature which increases its ability to carry current.

Fig. 1
SECTION OF A 4 POLE PROGRESSIVE LAP WINDING.

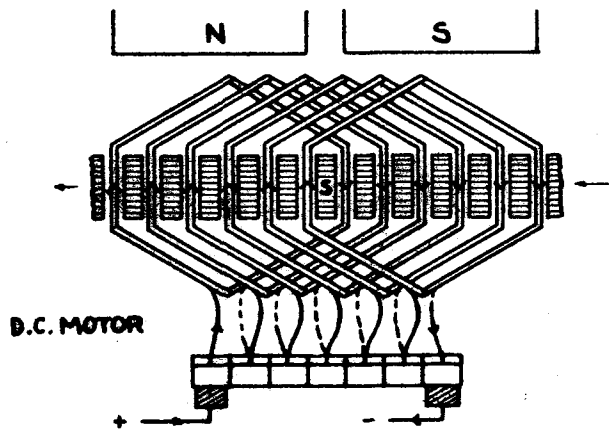
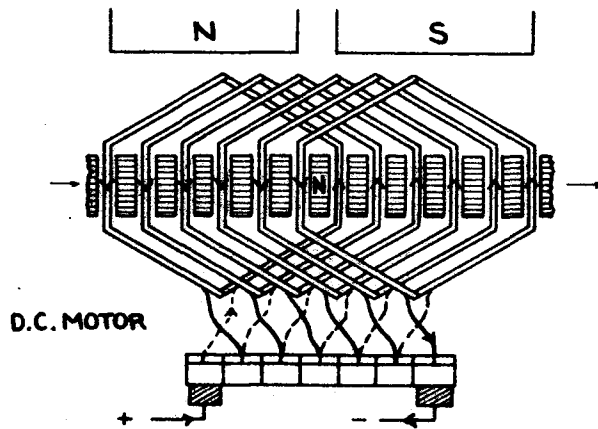

Fig. 2
SECTION OF A 4 POLE RETROGRESSIVE LAP WINDING.



The name wave wound is derived from the way the current circulates or waves through the armature. The wave type winding is usually used on a circuit where the operating voltage is 250 E or more in value. This type winding is desirable for traction work, steel mills & mine work. It is possible to design an armature for a higher operating voltage by having it wave wound. The higher operating voltage is obtained because there will be a greater number of armature coils in series between the brushes which increases the operating voltage.

Fig. 3
4 pole progressive wave winding.

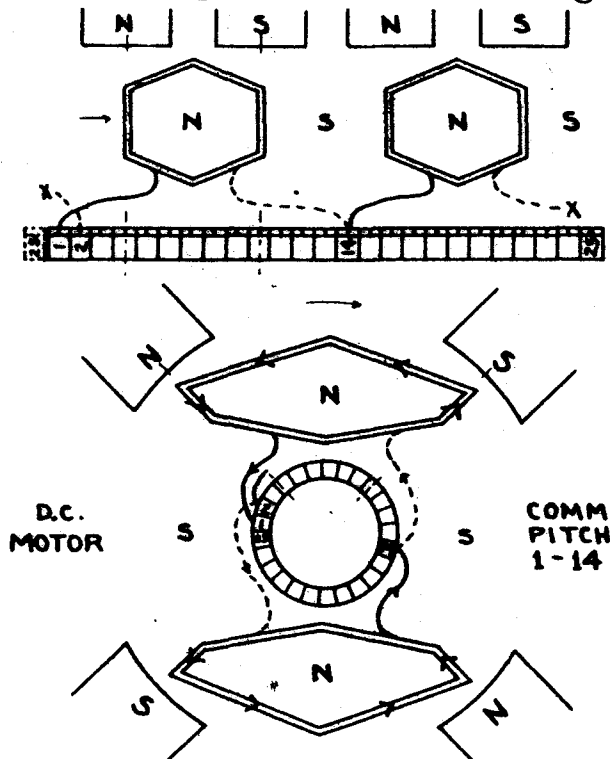
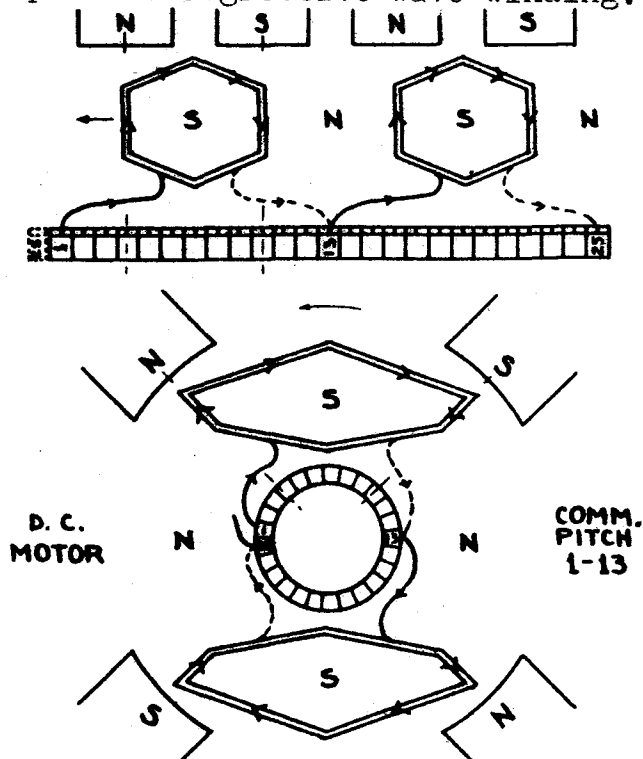
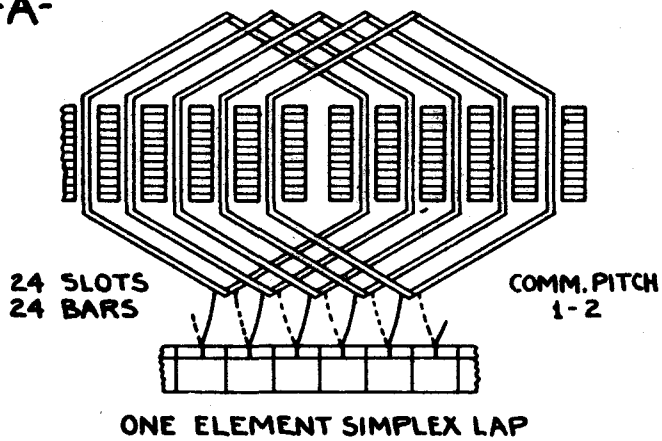

Fig. 4
4 pole retrogressive wave winding.



VARIOUS ARMATURE WINDING CONNECTIONS

-A-



-B-

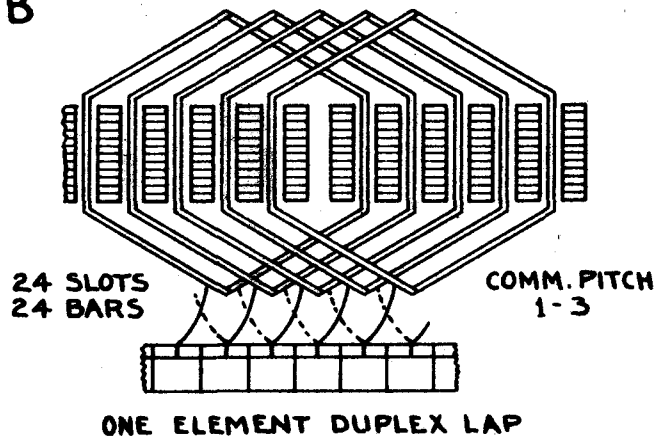

-C-

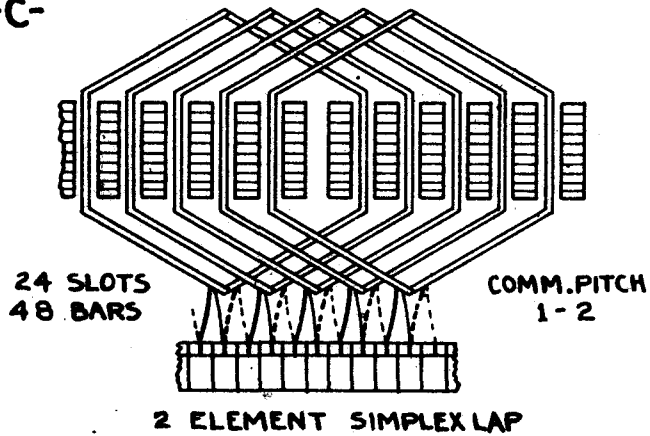

-D-

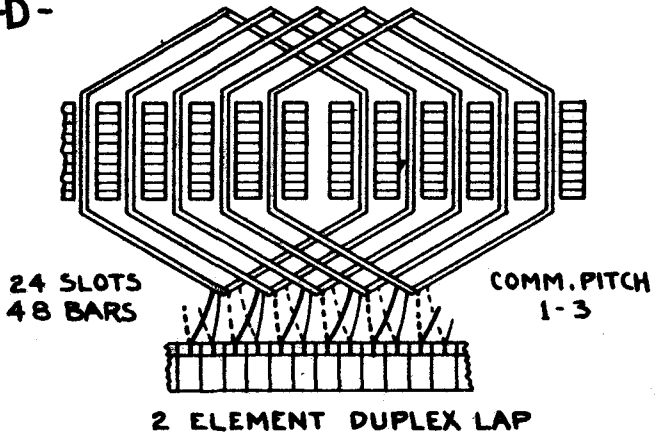

-E-

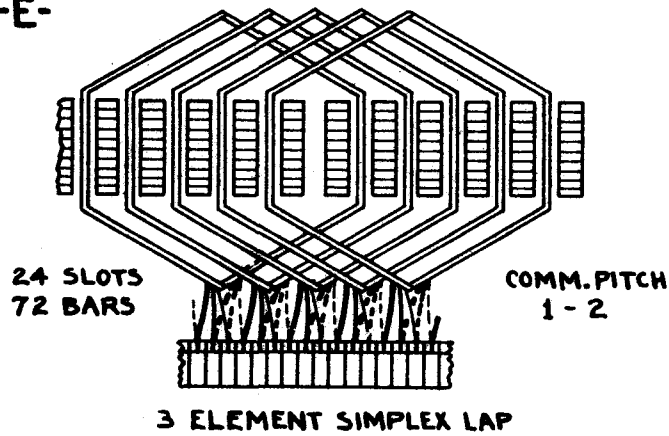

-F-

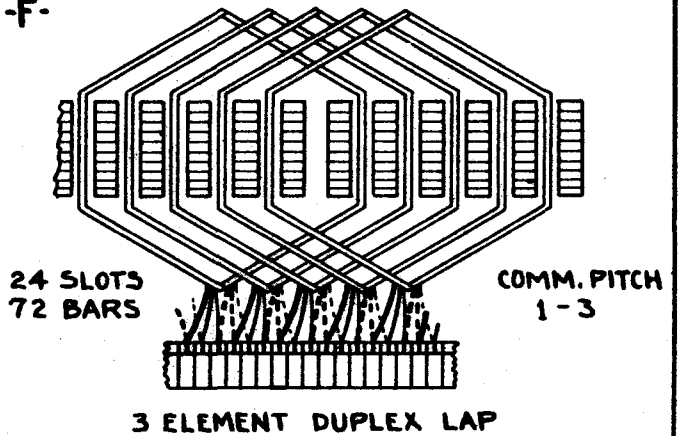

-G-

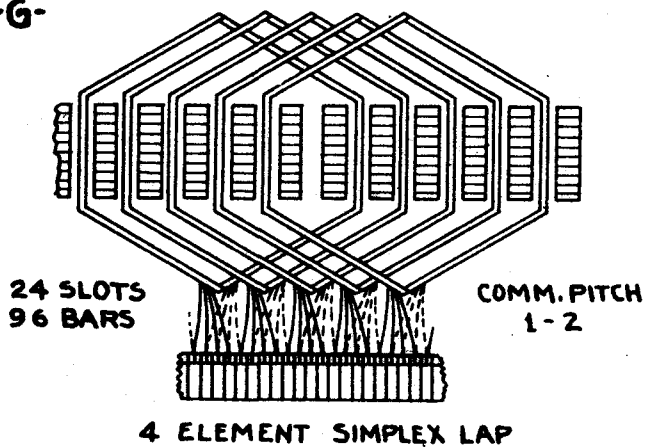

-H-

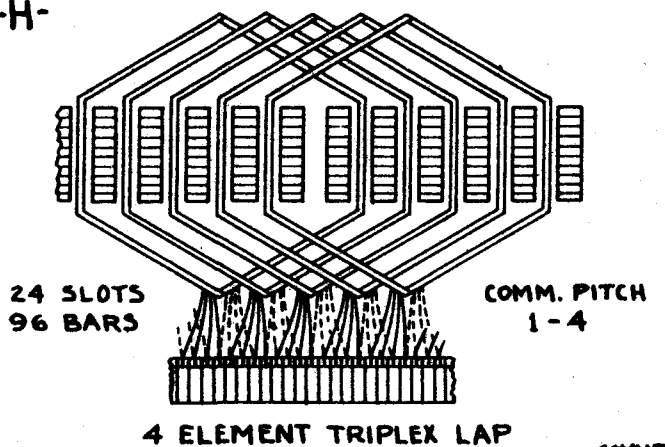

LAP WINDING
DUPLEX
PROGRESSIVE
SYMMETRICAL
SINGLE ELEMENT

SLOTS = 24
BARS = 24
POLES = 4
COIL SPAN = 1-7

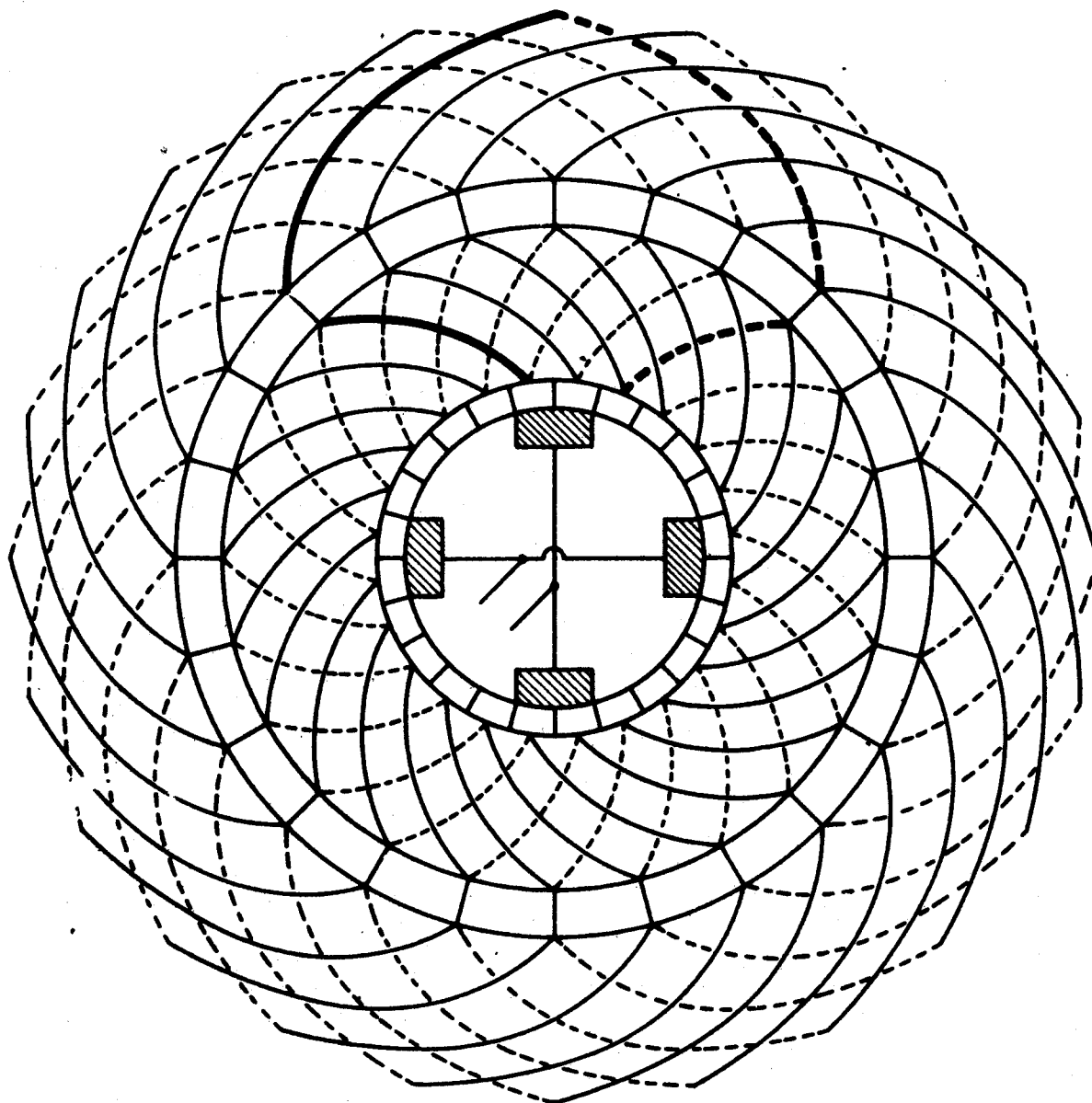

WAVE WINDING
SIMPLEX
RETROGRESSIVE
SYMMETRICAL
SINGLE ELEMENT

SLOTS = 25
BARS = 25
POLES = 4
COIL SPAN = 1-7
COMMUTATOR PITCH = 1-13

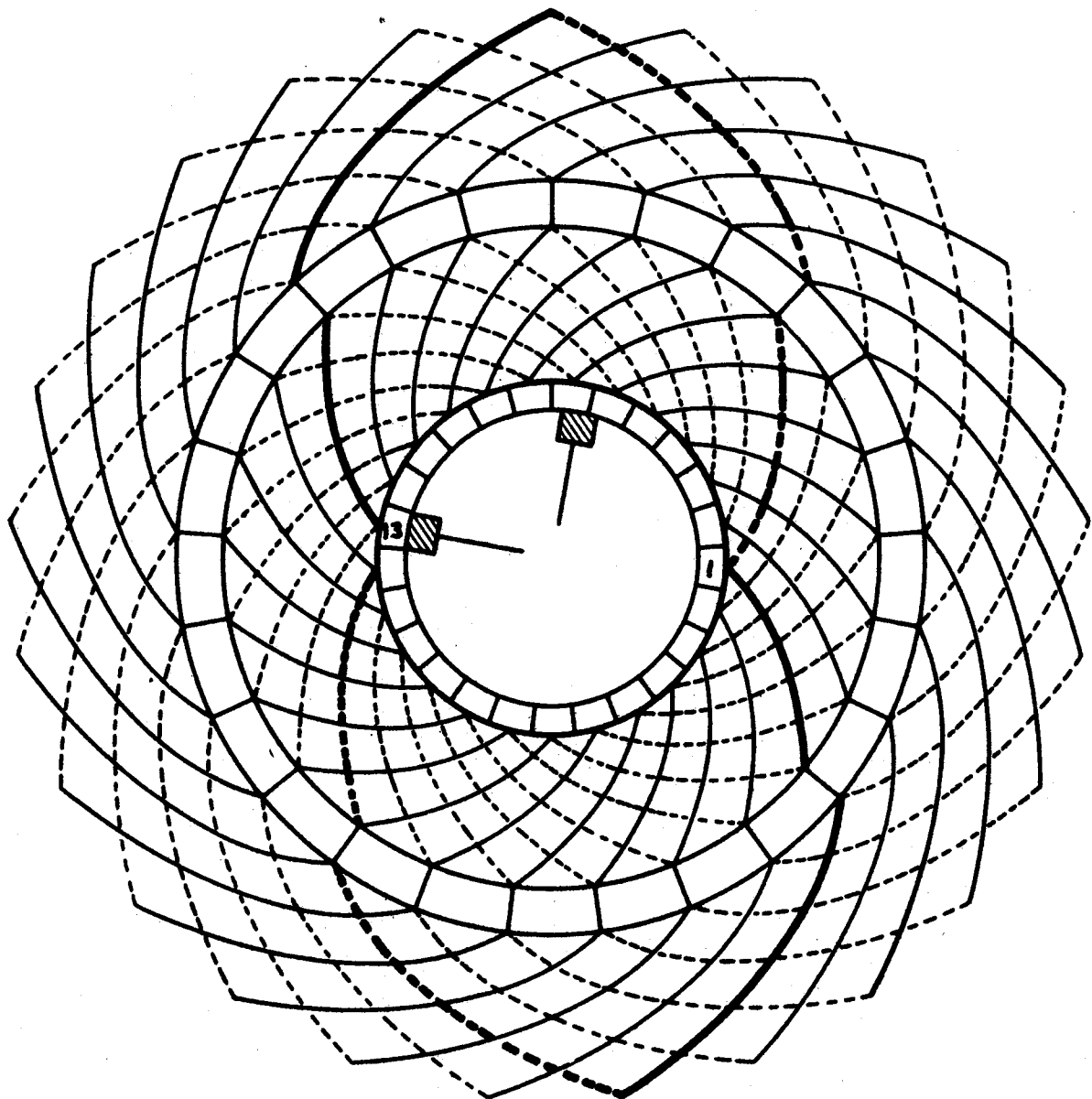

WAVE WINDING
SIMPLEX
PROGRESSIVE
SYMMETRICAL
SINGLE ELEMENT

SLOTS = 32
BARS = 32
POLES = 6
COIL SPAN = 1-6
COMMUTATOR PITCH = 1-12

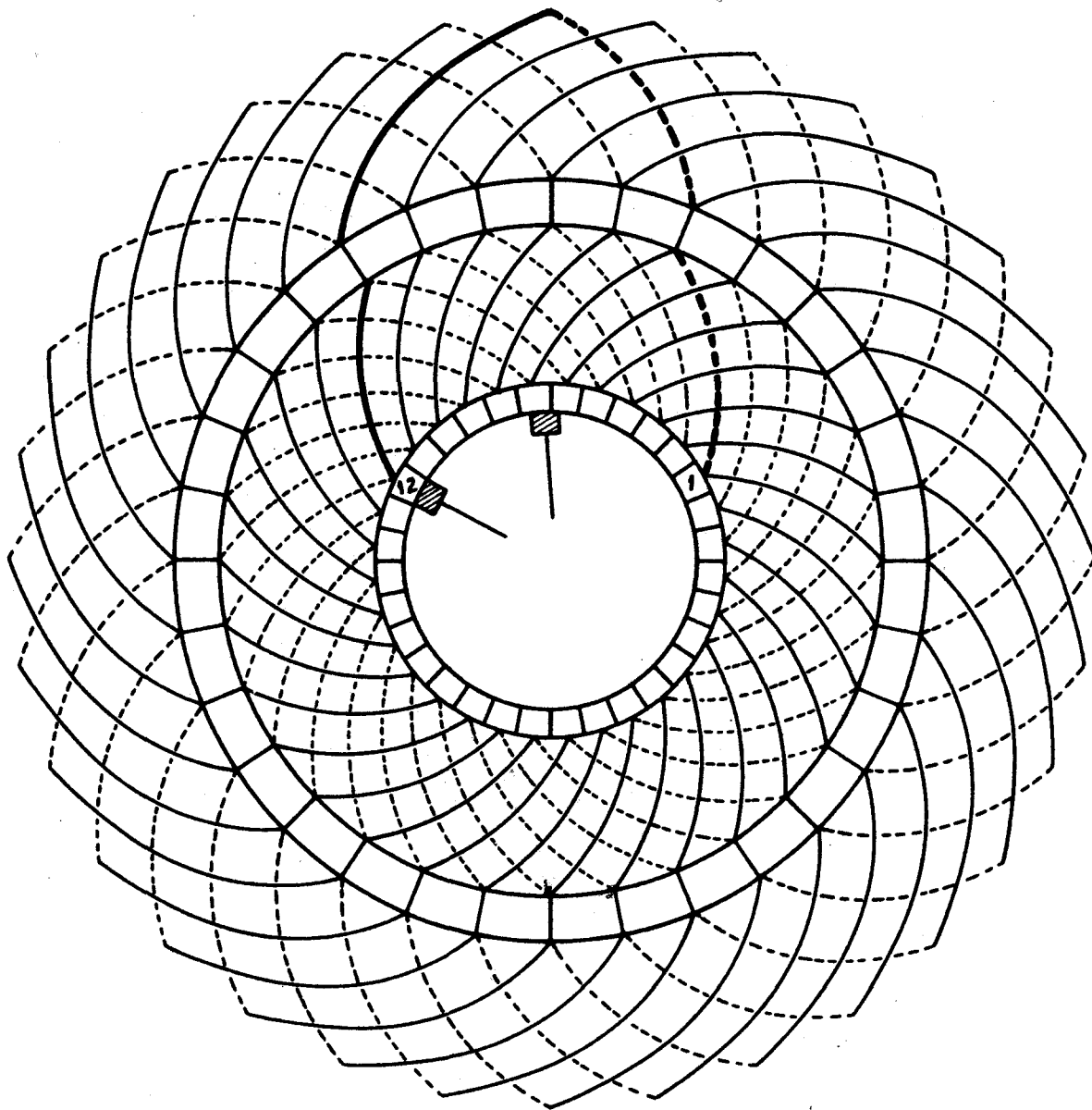

WAVE WINDING
 SIMPLEX
 RETROGRESSIVE
 SYMMETRICAL
 TWO ELEMENT

SLOTS = 13
 BARS = 25
 POLES = 4
 COIL SPAN = 1-4
 COMMUTATOR PITCH = 1-13

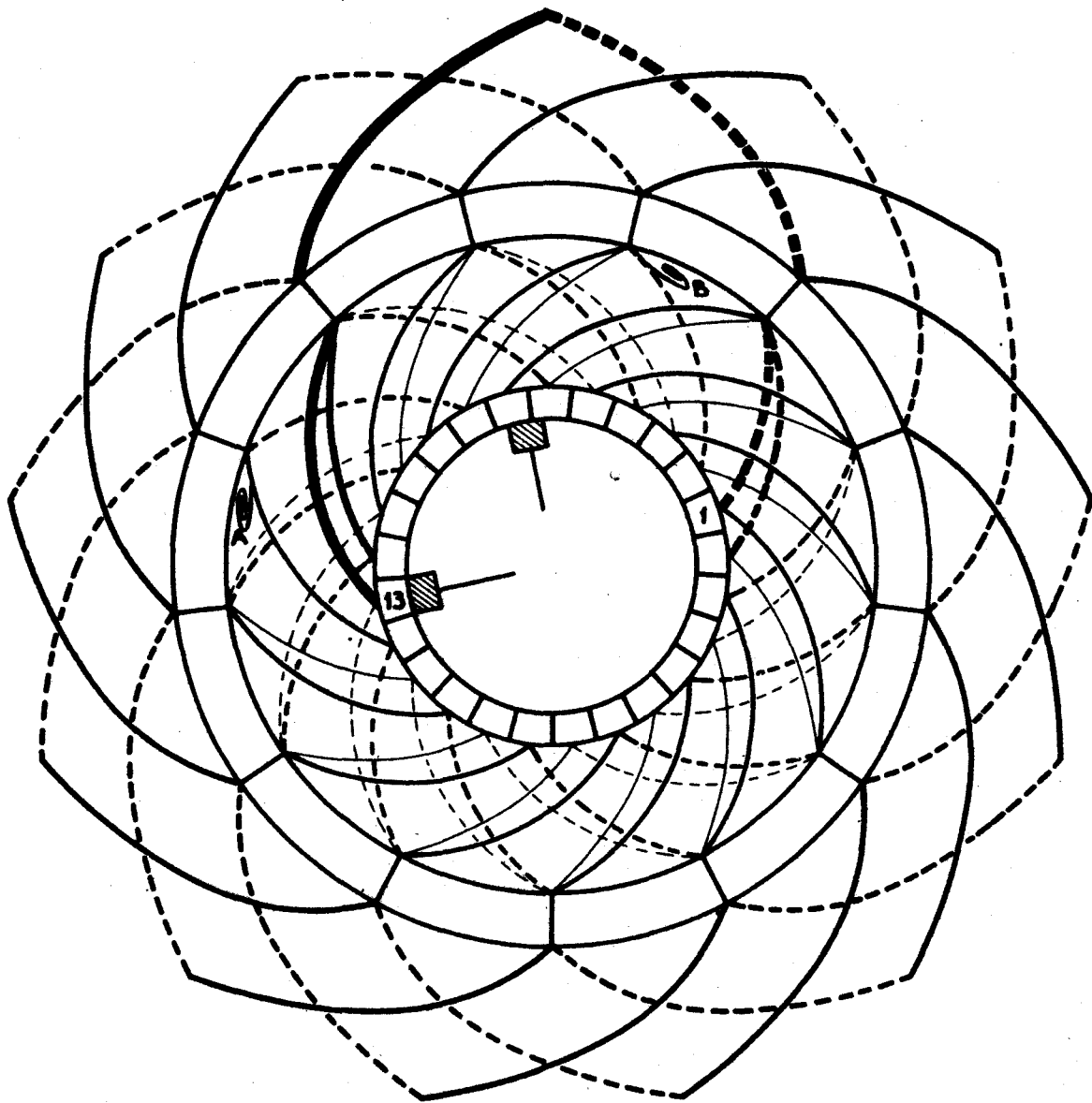

A - B ENDS OF DEAD COIL.

ARMATURE EQUALIZER CONNECTIONS.

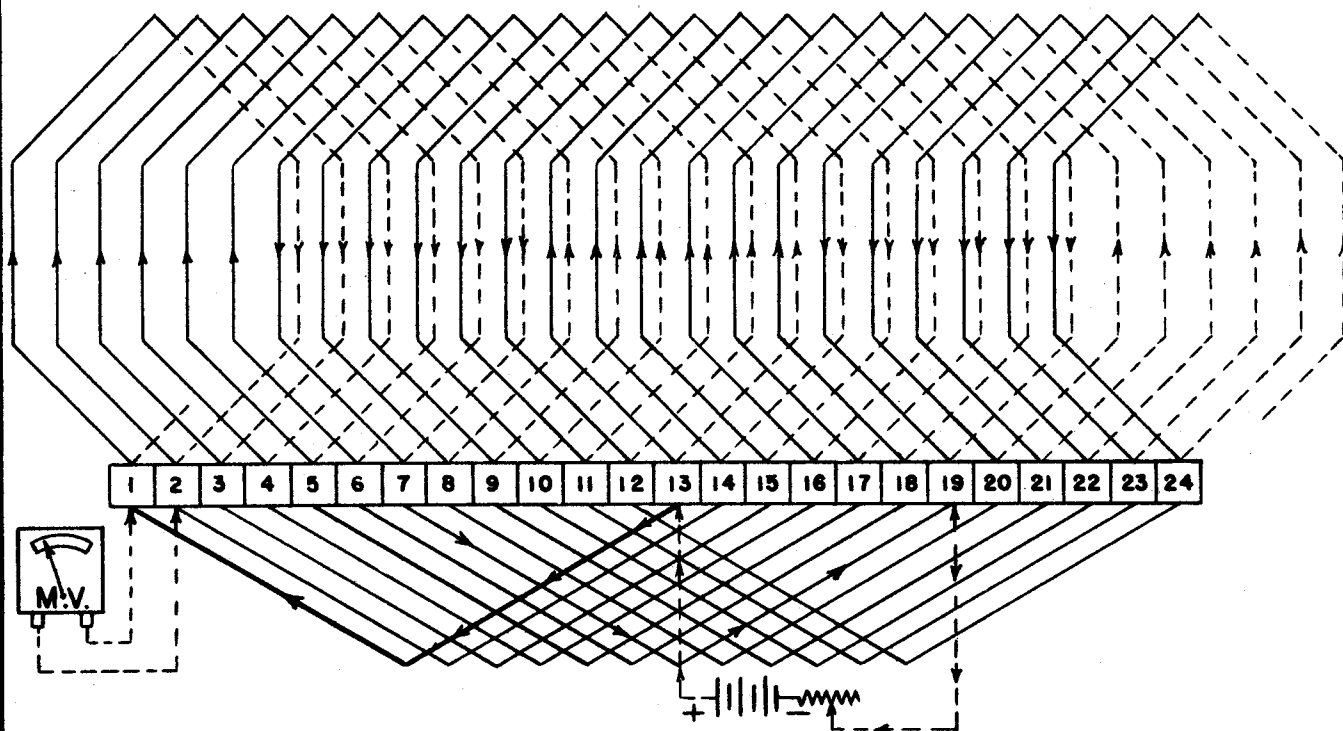

Although equalizers have been used on large armatures for many years, the application of these connections to small machines is a comparatively recent innovation that has raised questions regarding the advantages of such connections, and the method of testing such windings for faults.

Briefly, equalizer connections provide better commutation, make possible one-half the number of brushes usually used on the lap-wound machine, and provide the manufacturer with a means of avoiding the special slot and commutator bar relationships demanded by wave-type windings. Inasmuch as the equalizers here referred to are permanently connected to the commutator, and inasmuch as they make testing of the armature impossible by the regular procedure, the testing method and other information about these connections should prove of value to maintenance electricians and armature shop men.

The principal purpose of equalizers is to connect together on the armature those points which have the same polarity and which should

have equal potential. For a four-pole winding this means commutator bars 180 degrees apart; for a six-pole armature, bars 120 degrees apart; for an eight-pole machine, bars 90 degrees apart. The number of bars spanned by the equalizer will equal bars \div pairs of poles. For the armature shown in the diagram, each equalizer will span $24 \div 2$, or 12 bars, thereby making the connection 1 and 13, 2 and 14, etc. The pitch for any other number of bars or poles would be determined by the same method.

To test such an armature, current must be fed to the armature from an external low voltage D.C. supply, such as a battery, the leads being connected to commutator segments one-half the equalizer pitch apart. Since the equalizer pitch is 12 segments in this case, the leads will be spaced six bars apart or 1 and 7. Any pair of bars so spaced may be used, in a fully equalized armature; bars 13 and 15 being employed in the diagram.

The value of the test current is adjusted to give satisfactory deflection on the millivoltmeter, and voltage drop readings are taken between all adjacent pairs of segments.

These readings are interpreted in the usual manner, low readings indicating shorts, high readings showing high resistance connections or opens. Tracing the winding and also by actual test, it will be noted that if the readings from bars 13 and 19 are forward, then the readings from 19 to 1 will be backward. 1 to 7 will be forward, and 1 to 13 backward. This is a normal indication obtained in all windings.

If the factors mentioned are kept in mind, the procedure given will produce consistently accurate results. It is to be noted such an armature will, when tested on a growler, give a shorted indication on all coils, even though the winding is in perfect condition. The reason for this can be seen by tracing from bar 1 through the coil to bar 2, through the equalizer to bar 14, through the coil to bar 13 and back through the equalizer to bar 2. Thus every coil on the armature is apparently short circuited by having another coil placed in series with it through the equalizer connections. This explains the need for a special testing procedure.

DATA SHEET FOR MOTOR AND GENERATOR REWINDING

Job No. _____ Customer _____
 Address _____
 Date received _____ Date promised _____
 How delivered _____ Send _____ Will call _____
 Terms of payment _____ Estimate _____
 Cost of materials used _____ Total hrs. labor _____

WORK TO BE DONE

Write out in detail _____

REWIND DATA

H.P. _____ Volts _____ Amps. _____ R.P.M. _____ Type _____
 Serial No. _____ Make _____
 No. of slots _____ Coil span _____ Turns per coil _____
 Size and kind of wire _____ Wdg. conn. _____
 No. of wires in parallel _____ Lbs. of scrap wire removed _____
 Slot insulation _____
 No. of comm. bars. _____ Comm. pitch _____
 Dead coils _____ Dead bars _____ Wires per bar _____
 Dia. of core _____ Length of core _____ End room _____
 Band wires _____ Size _____ No. of turns _____ Solder balance weights _____

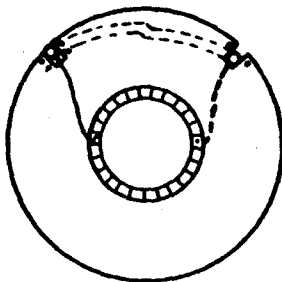

WAVE SIMPLEX SYM.

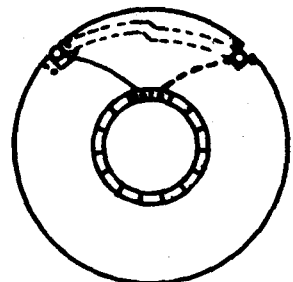
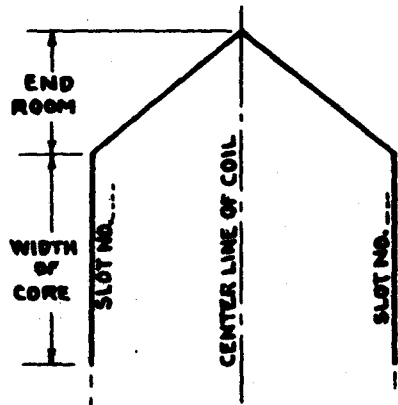

LAP SIMPLEX SYM.

DISTANCE FROM CORE TO COMPL.

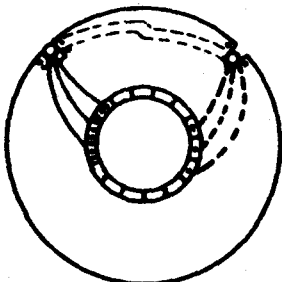
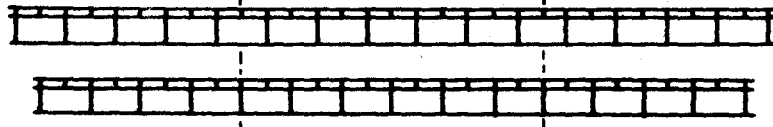

WAVE SIMPLEX SYM. 2 ELEMENT

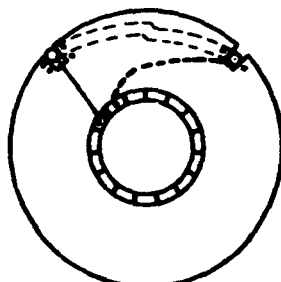

LAP SIMPLEX NON-SYM.

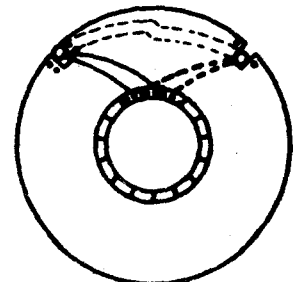

LAP SIMPLEX SYM. 2 ELEMENT

Coil Forming

The sketches show the method of making the right size coils for an armature winding.

The first step is to count the number of slots and commutator segments for determining the coil span and what element it is. After the coil span is found measurements should be according to Fig. 3 which shows the size a coil should be in relation to the average size armature. Notice particularly that the coil end extends $1/2$ " beyond the slot, $1/4$ " before spanning over to another slot. It can also be noticed that the twist (or curl) made in each end of the coil must be made at the exact center, otherwise the coils will not fit in properly.

Using a ruler, measure from a point $1/2$ " from the commutator in the exact center of the coil, (using a coil span of 1-7, slot #4, counting from #1 would be the center) to within $1/4$ " of slot #7. Referring to the armature in Fig. 3 this would be from C to D or $2-1/4$ ". Measuring from C to B would be $6-1/2$ ", and from A to B would be another $2-1/4$ " making a total of 11 inches for the length of the coil.

Set the coil winder (Fig. 1) at 11" and if the armature has twice as many segments as slots, or is two element, wind the two element coils with two wires in parallel, making both of the small coils in the two element coil in one operation. After the coils are wound on the winder they should be taped with cotton tape.

Referring to Fig. 2 which shows the method to use in forming the coil and bringing out the leads for both lap and wave wound coils note that coil should be taped before forming, assuming the approximate point where the lead should come out.

Extreme care must be taken in taping the coils to overlap exactly $1/2$ its width pulling each turn firmly against the wires of the coil (start taping the coil 1" from the end at which the leads are to be brought out).

The next step is shaping the coil. The slots in the coil former that will hold the coil while it is being shaped should be set $6-1/2$ " on the scale (the slot on the pull arm should also be the same width and height). To get the length of the coil from one point to the other, measure from the center of the coil along the 4th slot (starting within $3/4$ " of the commutator and letting the ruler extend out at the other end) to a point the same distance at the opposite side. Referring to Fig. 3 this would be from D to A or $8-1/2$ ". The adjustable rings on the shaft of the coil former will slide out so the holes in the knuckles will be held this distance ($8-1/2$ ") apart. Too much pressure should not be exerted in pulling the coil into position, as there is danger of breaking the insulation. When the coil has been stretched out the knuckles should be turned in the direction shown in Fig. 2, being very careful to see that the holes that the pins go through, to hold the coils in place, are exactly in the center of the coil.

Note:- The leads that extend from the coil when winding should be only long enough to reach to the end of the commutator bar opposite the riser. These ends should never be used to wind around the coil. Short lengths of wire may be used for this purpose, removing them as the coil is taped.

Note:- It is always good practice to make but one coil, shape it and try it on the armature to see if it is the exact size desired. Then if any alterations must be made only one coil will be wasted.

Coil Forming

Wires around coil to hold it together before taping.

scale in inches

adjustable

adjustable blocks

11"

FIG. 1 coil winder

FIG. 2 coil former

adjustable blocks

taped coil

8 1/2"

6 1/2"

adjustable blocks

pin

front view of knuckle

adjustable ring

commutator

wave

2 1/4"

lap

wave

FIG. 3 Coil in armature

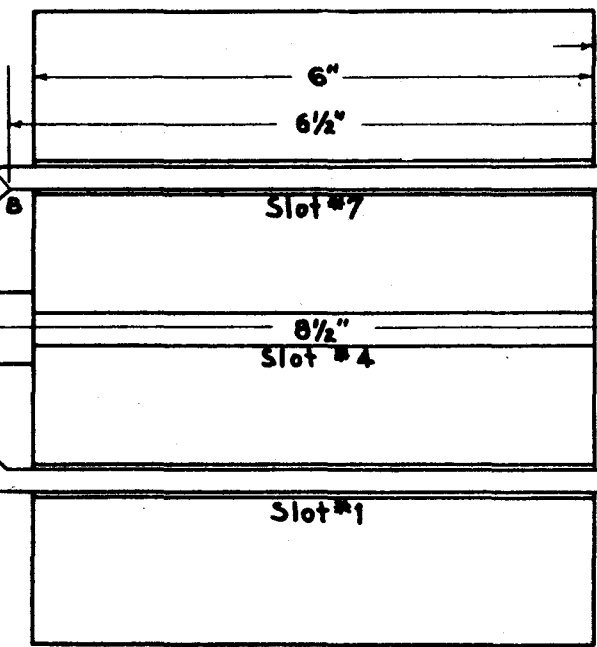

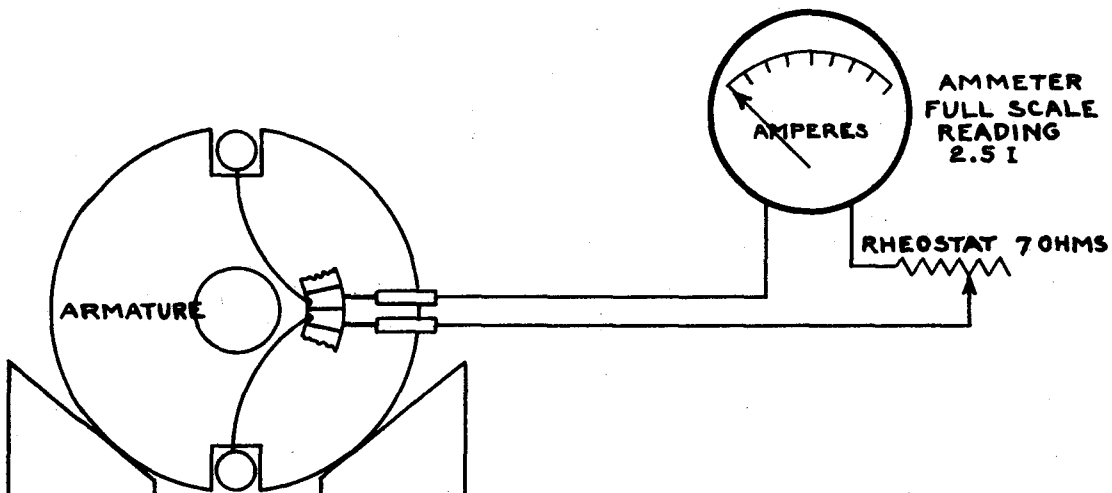

TWO COILS OF WIRE ARE USED EACH CONTAINING 250 TURNS OF #17 S.C.E. WIRE. THE COILS ARE INSULATED FROM EACH OTHER BY TWO LAYERS OF FISH PAPER AND TWO LAYERS OF EMPIRE CLOTH. THESE COILS MAY BE WOUND ONE OVER THE OTHER OR IN TWO SECTIONS AS SHOWN.

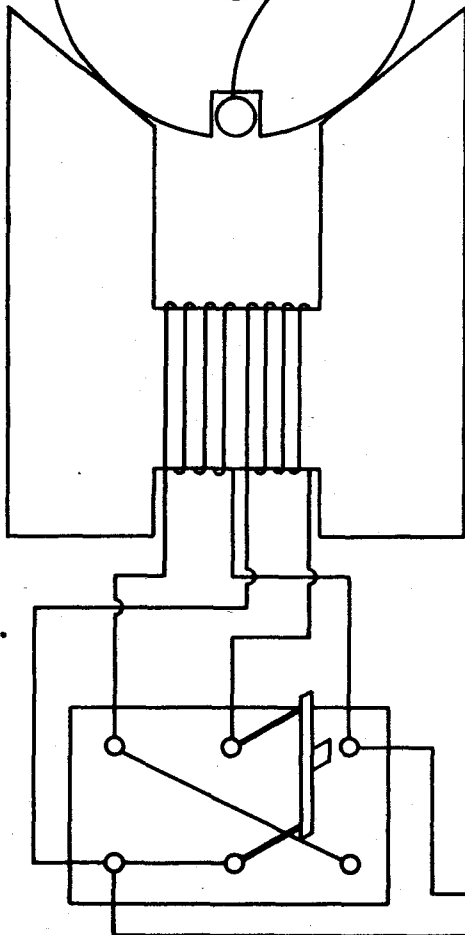

D.P.D.T. SW. USED TO CONNECT COILS IN SERIES OR PARALLEL FOR DIFFERENT STRENGTH MAGNETIC FIELDS

110E. 60~ A.C.

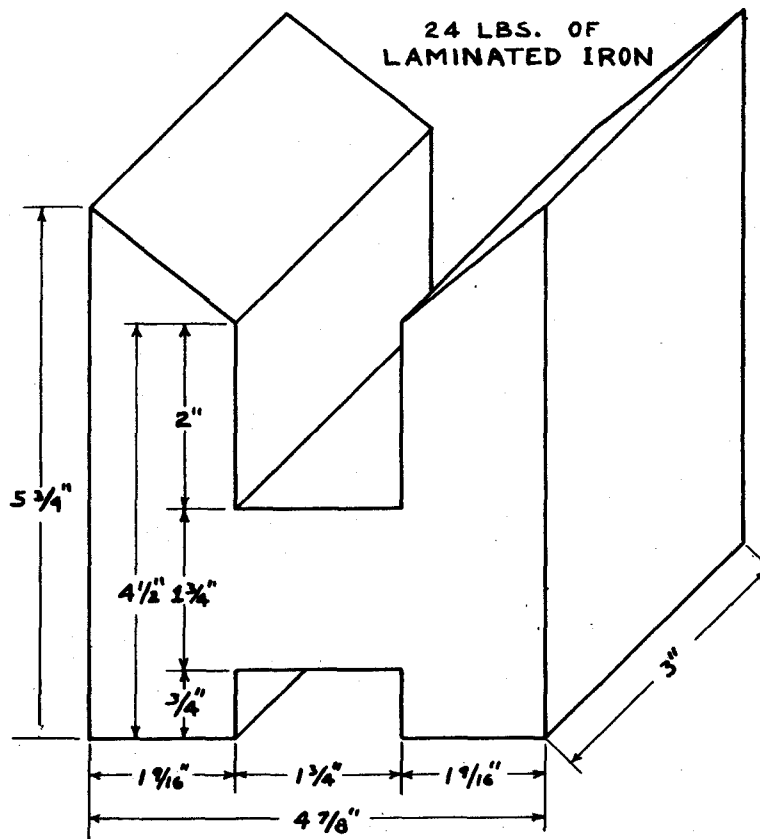

GROWLER SPECIFICATIONS

ARMATURE GROWLER TESTS

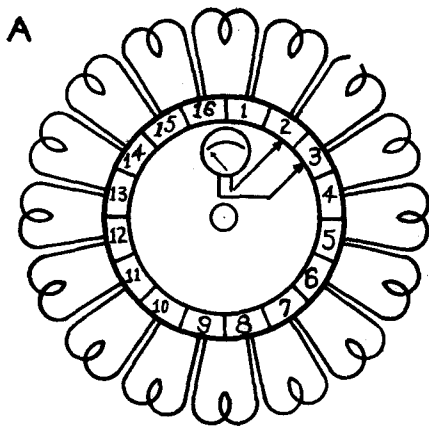

TROUBLE: OPEN COIL
THIS DEFECT SHOWS ITSELF ON THE OPERATING MACHINE BY EXCESSIVE SPARKING AT THE BRUSHES AND BURNING OF THE BARS ATTACHED TO THE COIL. WHEN TESTED ON THE GROWLER, THE METER READING BETWEEN BARS 1 AND 2 WILL BE ZERO. IF THE OPEN IS DUE TO POOR SOLDERING AT THE COMMUTATOR, RESOLDER. IF CAUSED BY AN OPEN IN THE COIL ITSELF, DISCONNECT THE LEADS, INSULATE THE ENDS, AND CONNECT A JUMPER FROM BAR 1 TO BAR 2.

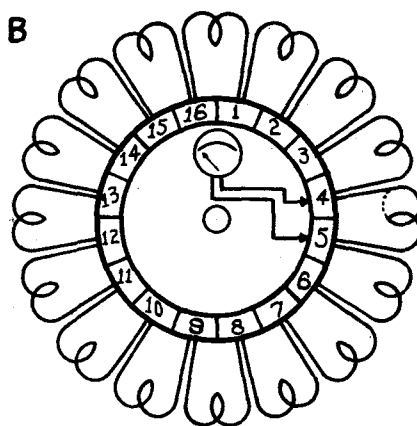

TROUBLE: SHORTED COIL
WHEN THE MACHINE IS IN OPERATION, A SHORTED COIL IS INDICATED BY THE EXCESSIVE HEAT IT GENERATES. WHILE OTHER COILS ON THE ARMATURE MAINTAIN A NORMAL TEMPERATURE, THE SHORTED COIL BECOMES SO HOT THAT IT BURNS THE INSULATION FROM THE WINDING. ON THE GROWLER, THE METER READING BETWEEN BARS 4 AND 5 WILL BE LOW OR ZERO. A HACKSAW BLADE WILL VIBRATE OVER THE SLOTS IN WHICH THE SHORTED COIL LIES.

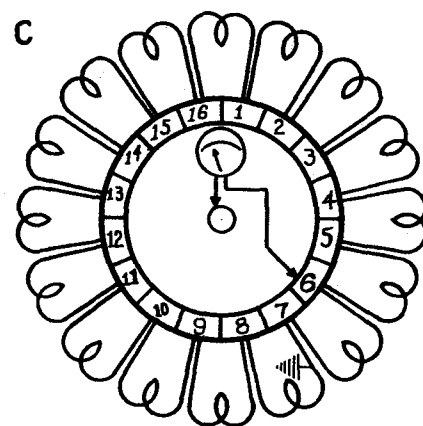

TROUBLE: GROUND COIL
A GROUND COIL WILL USUALLY GIVE NO INDICATION DURING OPERATION UNLESS THE FRAME OF THE UNIT BE UNGROUNDED; IN THIS CASE, A SHOCK MAY BE FELT WHEN TOUCHING THE FRAME. TWO GROUNDS ON THE ARMATURE PRODUCE A SHORT-CIRCUIT. ON THE GROWLER, A METER READING IS TAKEN BETWEEN THE COMMUTATOR BARS AND THE SHAFT. THE READING BECOMES LESS AS THE SHORTED BAR IS APPROACHED AND IS MINIMUM WHEN CONTACTED.

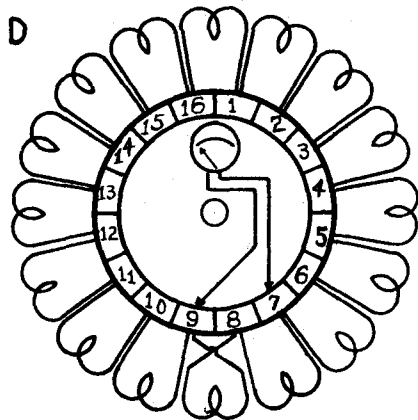

TROUBLE: REVERSED COIL LEADS
IN OPERATION, THIS DEFECT WOULD CREATE UNBALANCE IN THE ARMATURE CIRCUIT WITH THE RESULT THAT CIRCULATING CURRENTS WOULD FLOW AND TEND TO CAUSE OVERHEATING. ON THE GROWLER, MAKE A 1 TO 3 BAR TEST. WHEN TESTING BETWEEN BARS 7 AND 9, THE READING WOULD BE ZERO AND THE SAME READING WOULD BE OBTAINED BETWEEN BARS 8 AND 10. THIS WOULD INDICATE THAT THE LEADS OF THE COIL ATTACHED TO BARS 8 AND 9 ARE REVERSED.

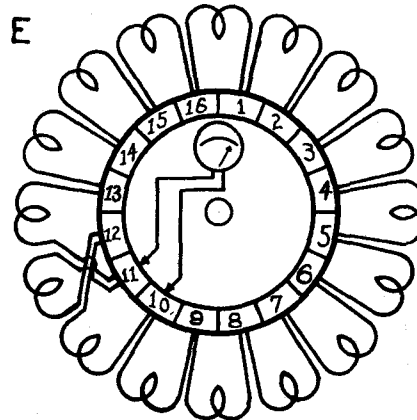

TROUBLE: REVERSED COIL LOOPS
THIS FAULT, WHICH USUALLY OCCURS IN A REMOUND MACHINE, MAY PRODUCE SPARKING AT THE BRUSHES DURING OPERATION. WHEN TESTED ON THE GROWLER, THE METER WILL SHOW A DOUBLE READING BETWEEN BARS 10 AND 11, A NORMAL READING ON 11 AND 12, AND A DOUBLE READING ON 12 AND 15. TO REMEDY, UNSOLDER LOOPS ON 11 AND 12 AND REVERSE THEM. HACKSAW WILL GIVE NO INDICATION OF THIS FAULT.

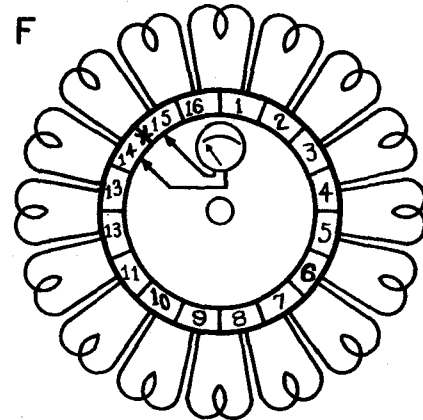

TROUBLE: SHORTED BARS
INDICATION DURING OPERATION IS OVERHEATING OF COIL ATTACHED TO BARS 14 AND 15 AND POSSIBLE SPARKING AT THE BRUSHES. ON GROWLER HACKSAW BLADE WILL VIBRATE OVER SLOTS CONTAINING COIL CONNECTED TO SHORTED BARS, AND METER READING BETWEEN 14 AND 15 WILL BE ZERO. REMEDY: REMOVE SHORT FROM BARS OR DISCONNECT COIL AND INSTALL A JUMPER FROM 14 TO 15.

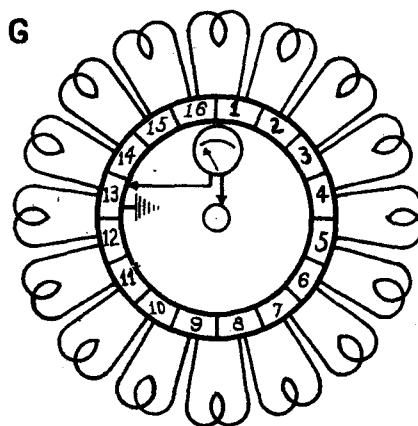

TROUBLE: GROUND BARS
IF THERE ARE NO OTHER GROUNDS ON THE MACHINE, THE FAULT WILL NOT AFFECT THE OPERATION OF THE MACHINE AT ALL. IF OTHER GROUNDS ARE PRESENT, SEVERE FLASHING AT THE BRUSHES WILL USUALLY OCCUR. THE TEST PROCEDURE IS THE SAME AS EMPLOYED IN DIAGRAM "C". TO DETERMINE IF GROUND IS COIL OR BAR, DISCONNECT WIRES FROM BAR 15 AND THEN TEST BAR FOR GROUND. REMEDY: REINSULATE BAR.

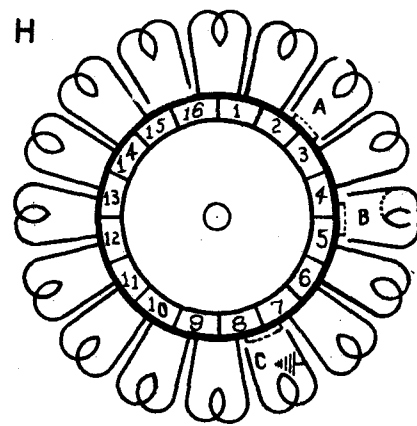

THIS SKETCH SHOWS HOW THE DIFFERENT FAULTS ABOVE LISTED ARE REMEDIED. THE LETTERS IN THE SKETCH REFER TO DIAGRAMS ABOVE IN WHICH THE FAULT IS GIVEN DETAILED TREATMENT. "A" SHOWS REMEDY FOR OPEN COIL, "B" FOR SHORTED COIL, "C" FOR GROUND COIL. DOTTED LINES BETWEEN BARS REPRESENT JUMPERS. NOTE THAT WITH A SHORTED COIL IT IS ESSENTIAL THAT THE COIL ITSELF BE CUT AS SHOWN IN "B" TO REMOVE THE SHORT CIRCUIT.

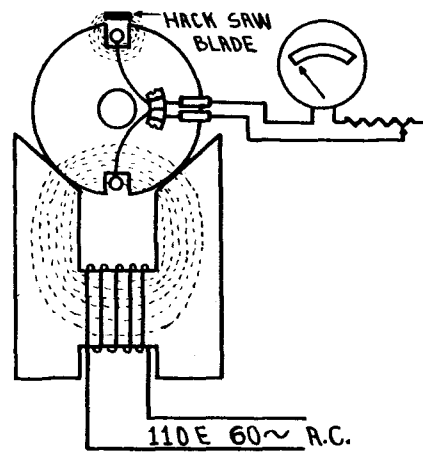

THE PURPOSE OF A GROWLER IS TO PRODUCE AN ALTERNATING MAGNETIC FIELD WHICH, CUTTING BACK AND FORTH THROUGH THE ARMATURE COILS, INDUCES IN THEM A LOW VOLTAGE MEASURABLE AT THE COMMUTATOR BARS WITH AN A.C. MILLIVOLTMETER. THE RESISTANCE "R" IS USED TO ADJUST THE READING TO APPROXIMATELY MIDSCALE. WHEN A SHORTED COIL IS PLACED BETWEEN THE GROWLER JAWS, THE HEAVY CURRENT SET UP IN THE COIL CAUSES PERIODIC MAGNETIZATION OF THE SLOT IN WHICH THE COIL LIES, RESULTING IN THE HACKSAW BLADE HELD NEAR THE SLOT BEING ALTERNATELY ATTRACTED AND RELEASED.

ARMATURE TESTS USING METER

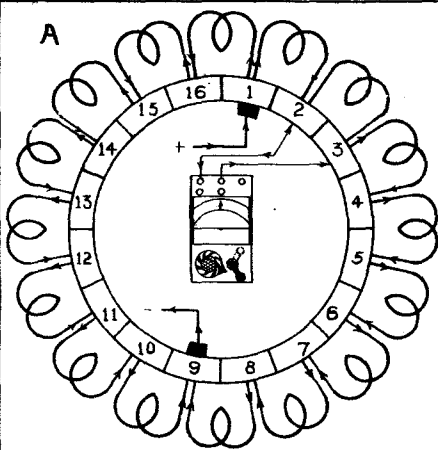

TROUBLE - OPEN COIL
TO PREVENT INJURY TO THE METER, THIS TEST MUST PRECEDE ALL OTHERS WHEN THE MILLIVOLT METHOD OF TESTING IS USED. SET METER ON THE 15 VOLT RANGE AND, WITH CURRENT FLOWING THROUGH THE ARMATURE, TAKE READINGS BETWEEN BARS 1-2, 2-3, 3-4, ETC., UNTIL ALL PAIRS OF SEGMENTS HAVE BEEN COVERED. A HIGH READING BETWEEN ANY PAIR OF BARS INDICATES AN OPEN COIL. NOTE THAT IN THIS METHOD OF TESTING THE METER IS USED TO MEASURE THE VOLTAGE DROP IN EACH ARMATURE COIL, AND THAT THIS IS DONE BY TAKING READINGS BETWEEN COMBUTATOR SEGMENTS.

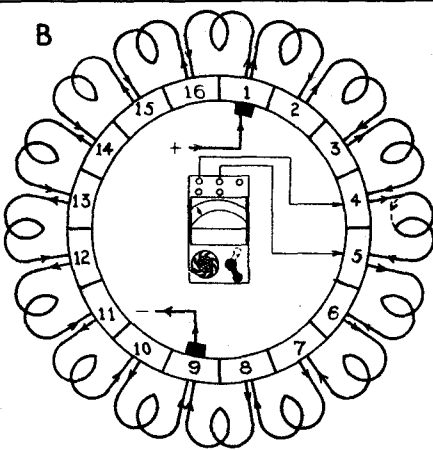

TROUBLE - SHORTED COIL
FOR THIS TEST SET METER ON THE M.V. RANGE THAT GIVES THE BEST DEFLECTION, STARTING WITH THE 500 SETTING AND WORK DOWN TO THE 50 M.V. RANGE IF NECESSARY. ADJUST CURRENT THROUGH ARMATURE UNTIL APPROXIMATELY MIDSCALE DEFLECTION IS OBTAINED ON A NORMAL COIL AND MAKE A BAR-TO-BAR TEST ON ALL SEGMENTS. THE DEFECTIVE COIL WILL GIVE A LOW OR ZERO READING DEPENDING UPON HOW MANY TURNS ARE SHORTED. IT SHOULD HERE BE UNDERSTOOD THAT THIS METHOD OF TESTING IS MERELY A COMPARATIVE ONE, FOR IT IS HOW THE READINGS COMPARE THAT IS IMPORTANT.

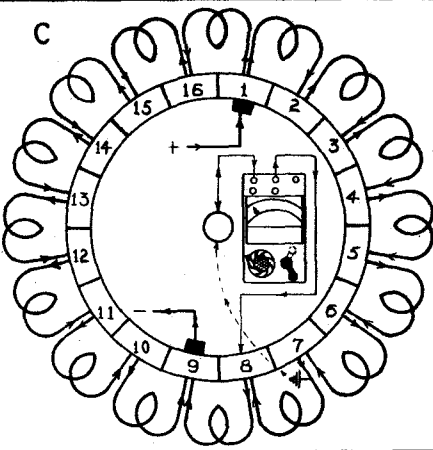

TROUBLE - GROUND COIL
TO MAKE THIS TEST, SEND A CURRENT OF SUITABLE VALUE THRU THE ARMATURE AND MEASURE THE VOLTAGE DIFFERENCE BETWEEN EACH SEGMENT AND THE ARMATURE SHAFT. IF THE WINDING IS GROUND, A READING WILL BE OBTAINED THAT BECOMES GRADUALLY LESS AS THE BARS TO WHICH THE GROUND COIL IS CONNECTED ARE APPROACHED. THE READING WILL BE LOWEST ON THE BARS TO WHICH THE GROUND COIL IS CONNECTED. IT SHOULD ALSO BE NOTED THAT AS THE GROUND COIL IS PASSED THE METER READING WILL REVERSE. TO DETERMINE IF THE BAR IS GROUND, DISCONNECT THE COIL LEADS AND REPEAT.

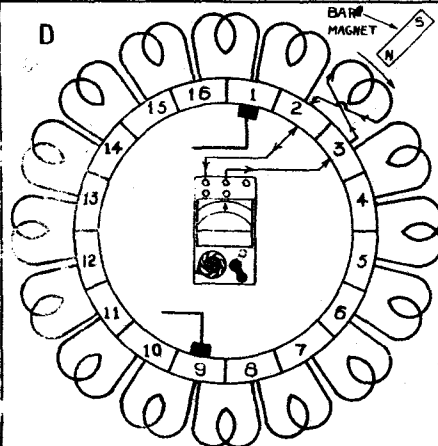

TROUBLE - REVERSED COIL LEADS
USUALLY ENCOUNTERED ON ARMATURES THAT HAVE JUST BEEN REWOUND, THIS FAULT REQUIRES A DIFFERENT TESTING METHOD. SET METER ON 50 M.V. RANGE, SELECT THE FIRST COIL TO BE TESTED, AND FIND THE SEGMENTS TO WHICH THE ENDS OF THIS COIL ARE CONNECTED. WITH THE METER LEADS ON THESE BARS DRAW A MAGNET SWIFTLY ACROSS THE SLOT IN WHICH ONE SIDE OF THE COIL LIES AND NOTE DEFLECTION ON THE METER. REPEAT THIS TEST ON ALL OTHER COILS, ALWAYS MOVING THE MAGNET IN THE SAME DIRECTION. WHEN DRAWN ACROSS A REVERSED COIL, THE METER WILL READ BACKWARDS.

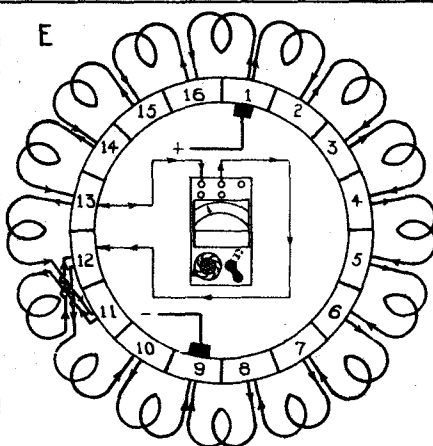

TROUBLE - REVERSED COIL LOOPS
USUALLY FOUND ONLY IN REWOUND MACHINES, THIS FAULT IS CHECKED BY THE REGULAR BAR-TO-BAR TEST. PROCEED IN EXACTLY THE SAME MANNER AS USED FOR LOCATING SHORTED COILS SINCE THE CURRENT IN PASSING FROM SEGMENT 10 TO SEGMENT 11 MUST FLOW THROUGH TWO COILS, IT FOLLOWS THAT THE VOLTAGE DROP BETWEEN BARS 10 AND 11 WILL BE DOUBLE THE VALUE OBTAINED ON A NORMAL COIL; THE SAME IS TRUE FOR BARS 12 AND 13. BARS 11 AND 12 WILL GIVE A NORMAL INDICATION; THUS REVERSED COIL LOOPS ARE INDICATED BY A DOUBLE READING, A NORMAL READING, AND A DOUBLE READING.

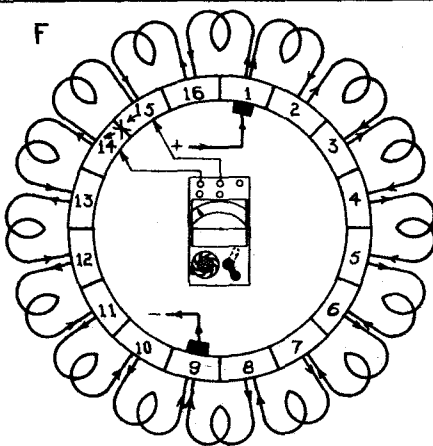

TROUBLE - SHORTED BARS
MAKE SAME TEST AS FOR SHORTED COIL. WITH CURRENT FLOWING THROUGH THE ARMATURE, MEASURE THE VOLTAGE DROP BETWEEN SEGMENTS. WHEN THE SHORTED BARS ARE ENCOUNTERED, THE METER WILL READ ZERO. INASMUCH AS THE SAME INDICATION WOULD BE OBTAINED IF THE COIL LEADS WERE SHORTED, IT WILL BE NECESSARY TO DISCONNECT THE LEADS FROM THE COMBUTATOR SEGMENTS BEFORE IT CAN BE DETERMINED WHETHER THE LOW READING WAS CAUSED BY SHORTED BARS OR SHORTED COIL LEADS. IF AFTER THE COIL IS DISCONNECTED A ZERO READING IS OBTAINED, THE BARS ARE SHORTED.

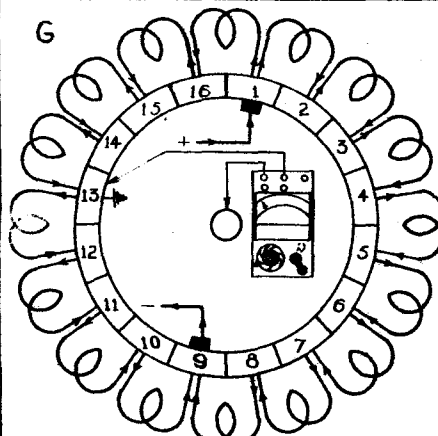

TROUBLE - GROUND BARS
TEST FOR THIS DEFECT IS THE SAME AS FOR A GROUND COIL. METER READING FROM BAR TO SHAFT WILL BE ZERO WHEN THE GROUND BAR IS CONTACTED. TO DETERMINE WHETHER THE BAR OR THE COIL IS GROUND, DISCONNECT THE COIL FROM THE BAR AND TEST AGAIN; IF BAR NOW TESTS CLEAR, COIL IS GROUND. WHEN MAKING THIS TEST, THE METER READINGS MAY CHANGE SO RAPIDLY AS THE GROUND IS APPROACHED, THAT A SATISFACTORY DEFLECTION CANNOT BE OBTAINED WITHOUT TURNING TO A DIFFERENT RANGE. THEREFORE, AS THE READING FALLS, THE METER SWITCH SHOULD BE MOVED TO A LOWER RANGE.

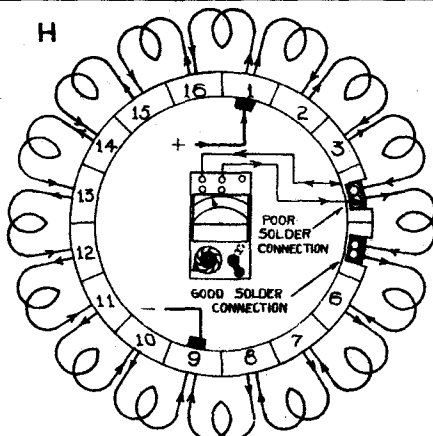

TROUBLE - BAD CONNECTIONS
TROUBLE FREQUENTLY DEVELOPS IN ARMATURES AS THE RESULT OF POOR ELECTRICAL CONNECTIONS BETWEEN THE COIL LEADS AND THE COMBUTATOR SEGMENTS DUE EITHER TO POOR SOLDERING OR TO OVERHEATING OF THE ARMATURE WHILE IN SERVICE. HIGH RESISTANCE CONNECTIONS OF THIS TYPE ARE INDICATED BY HIGH READINGS ON THE MILLIVOLTMETER. TO POSITIVELY LOCATE WHICH BAR HAS THE POOR CONNECTION, MAKE THE TEST INDICATED ABOVE. A POORLY SOLDERED JOINT WILL PRODUCE A READABLE DEFLECTION ON THE METER, WHEREAS A

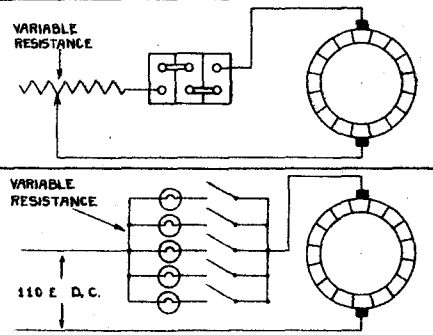

TESTING PROCEDURE
CONNECT THE ARMATURE TO A 6 VOLT, 110 VOLT, OR OTHER D.C. SUPPLY WITH A CONTROLLING RESISTANCE IN SERIES. THIS RESISTANCE MAY CONSIST OF A NUMBER OF PARALLEL-CORRECTED LAMPS ARRANGED TO BE SWITCHED IN OR OUT OF THE CIRCUIT AT WILL. SEND CURRENT INTO ARMATURE THROUGH BARS EXACTLY ONE POLE PITCH APART, AND ADJUST CURRENT UNTIL THE MILLIVOLTMETER GIVES A MIDSCALE READING ON A NORMAL COIL. THE AMOUNT OF D.C. CURRENT REQUIRED WILL VARY WITH THE SIZE OF THE ARMATURE, FRACTIONAL H.P. UNITS REQUIRING ABOUT 2-4 AMPS, MACHINES UP TO 20 H.P. ABOUT 10 AMPS, AND THE LARGEST ARMATURES CURRENTS AS HIGH AS 20 AMPS. AFTER THE CURRENT HAS BEEN ADJUSTED TO A SUITABLE VALUE, TAKE MILLIVOLT READINGS BETWEEN BARS 1-2, 2-3, 3-4, ETC. IF NO FAULTS ARE PRESENT, THE READINGS WILL BE APPROXIMATELY EQUAL. HIGH READINGS INDICATE HIGH RESISTANCE CONNECTIONS, USUALLY CAUSED BY POOR SOLDERING. WHILE IN

OPEN ARMATURE COIL TEST

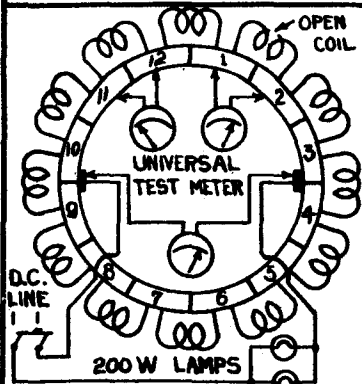

Connect armature across line with current-limiting lamps in series. Place meter selector switch in the 50 volt or the 10 volt position and measure voltage across armature. Next make a bar-to-bar test; meter will read zero until open coil is bridged when total armature voltage will be registered. Example: 8E across armature; bars 11, 12 read zero; bars 1, 2 read 8E. To protect the meter, the test for spans should always be made before any other check involving bar-to-bar readings.

SHORTED ARMATURE COIL TEST

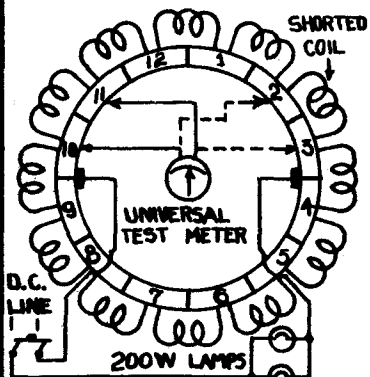

Connect armature to circuit, as directed above. Set meter selector switch to 250 M.A. and make a bar-to-bar test. If necessary, change selector switch to obtain about half-scale reading on a normal coil. A low or zero reading will then indicate a shorted coil; a high reading a poor connection - usually at the commutator riser. Example: Meter reads half scale on bars 11-12, 12-1, 1-2; gives low reading on 2-3, thereby indicating a shorted coil.

GROUNDING ARMATURE COIL TEST

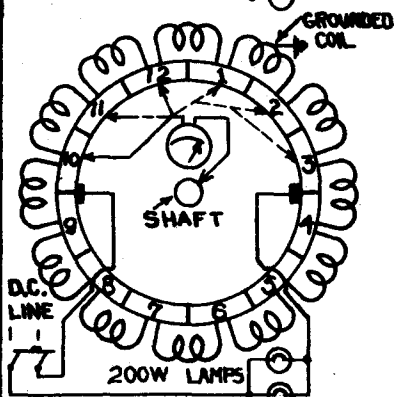

With the test connection remaining the same as before, a meter reading between the commutator segments and the shaft indicates a grounded coil. As the segment to which the grounded coil is connected is approached, the reading will become less and will be minimum when the test prod is in contact with the segments connected to the grounded coil. Example: With meter selector switch set on 50 M.A., a reading from bar 10 to shaft is full-scale and this value is gradually reduced to a minimum on bars 1 and 2. Beyond this point, the reading reverses and starts to increase again.

SHORTED FIELD COIL TEST

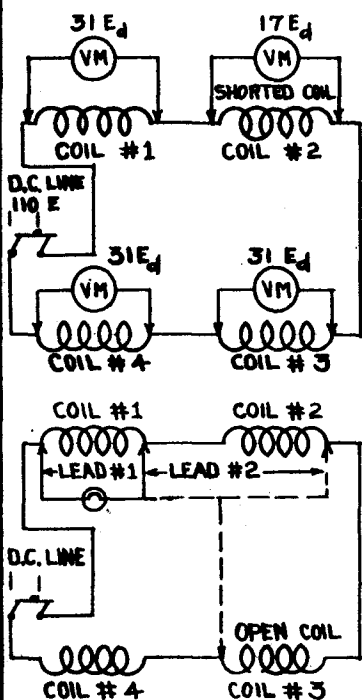

Connect shunt field to line as shown in sketch and take the voltage drop across each field coil with a D.C. voltmeter. If the voltage across all coils is the same, the field is O.K. A reading below normal indicates a shorted or partially shorted coil. The normal voltage across any field coil is equal to the line voltage divided by the number of poles. Example: Coil 1, 31E; coil 2, 17E; coil 3, 31E; coil 4, 31E; coil 2 is shorted.

OPEN FIELD COIL TEST

Connect field as indicated in sketch and place voltmeter or test lamp across each field coil. If the field is open, no reading will be obtained until the open in the circuit is bridged. Then the open may be found by testing each coil individually, or by connecting one test lead to one of the circuit wires and moving the other lead around the field toward the other line until a light is obtained. The open will then be in between the point at which the light was obtained and the previous point tested.

GROUND FIELD TEST

Apply line voltage between the field leads and the frame with a suitable voltmeter or test lamp in series. If the meter indicates or the lamp lights, the field is grounded. To locate the ground, disconnect and test each coil separately.

INSULATION TESTS

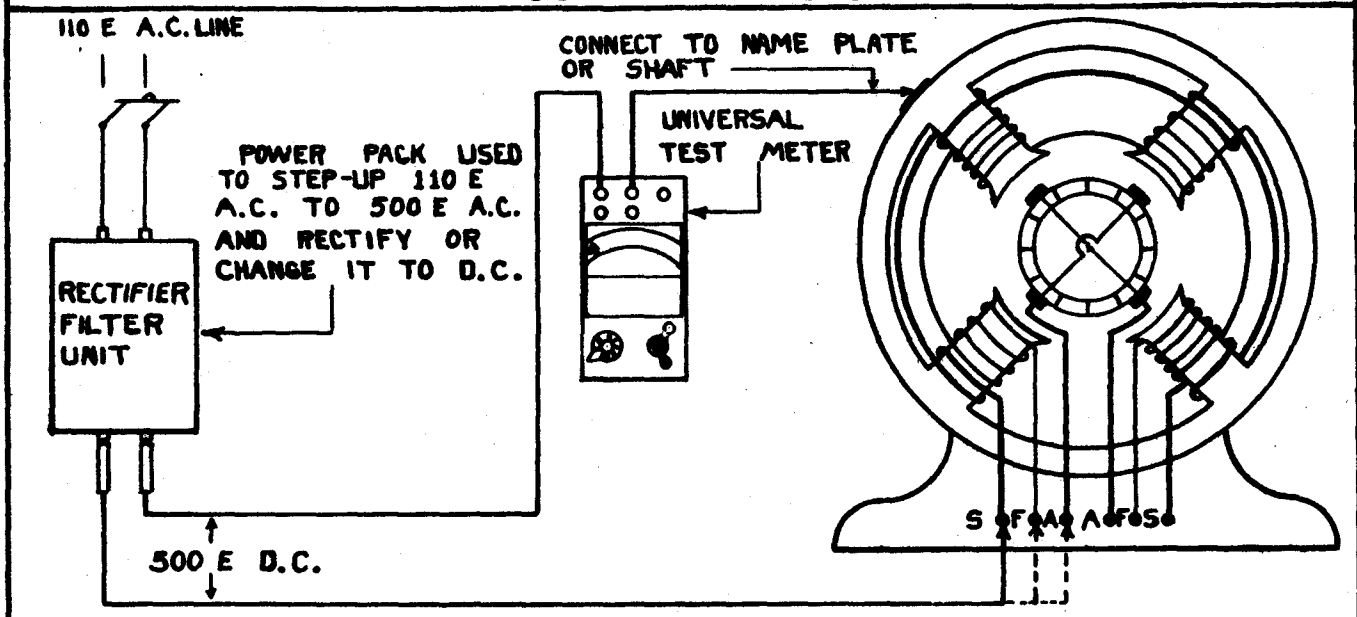

Since the quality of the insulating materials used on any electrical machine deteriorates with age, due to the action of moisture, dirt, oil, acids, etc., it is necessary to periodically test the electrical resistance of the insulation so that weaknesses may be detected and corrected before they result in complete failure.

Insulation resistance tests are usually made up applying 500 volts D.C. between the winding of the machine and the frame; the current which this pressure forces through or over the insulation to the frame is measured by a sensitive instrument, the scale of which is usually calibrated to read in megohms. The 500 volts D.C. may be developed by a hand-operated generator as in the megger, or it may be supplied from an A.C. source by a rectifier-filter combination as shown above.

The readings obtained on any given machine will vary greatly with the temperature of the insulation, a 10 degree Centigrade rise in temperature reducing the insulation resistance as much as 50%. The dampness of the location, and the amount of oil, dust, or dirt on the winding, will also materially affect the readings. Wherever possible, the test should be made when the insulation is at the maximum operating temperature, 167 degrees F., (75 degrees C.) The minimum safe insulation resistance at maximum operating temperature should not be lower than one megohm for equipment having a voltage rating below 1000 volts.

To make the test, connect the rectifier unit to 110 volts A.C., set the control switch on the meter to the one mil position, set switch in D.C. position, make the connections shown above, and read the insulation resistance on the top scale of the dial. Usually a general test is made between one lead of the machine and the frame, and if this proves to be too low, the windings are tested individually. So after the general test, test the armature, shunt field, series field, and brush holders separately. To do this, take the brushes from the holders, disconnect the windings from each other, and test the insulation resistance of each. In this manner, the faulty element can quickly be found. This same procedure is used on A.C. equipment also. If such readings are taken at regular intervals and the values recorded, a close check may be kept on the condition of the insulation resistance of all electrical equipment, and apparatus may be removed from service and reconditioned before breakdown occurs.

POWER PACK FOR INSULATION RESISTANCE TESTER

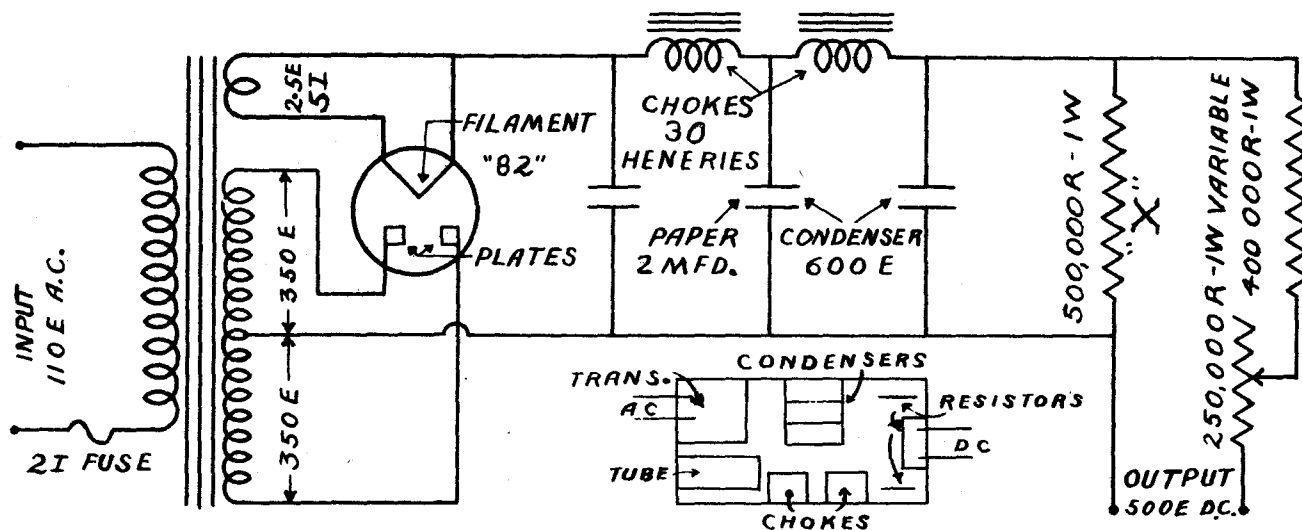

The connecting scheme employed on unit designed to convert 110 volt, 60 cycle A.C. to 500 volt D.C. for insulation resistance testing is shown above. Many of the parts required for this rectifying and filtering device may be obtained from old radio equipment; the remainder may be purchased from any radio supply store. The material needed is listed below.

- One power transformer with windings to produce voltages shown.
- Three 600 volt, 2 microfarad, paper condensers.
- Two 30 henry chokes. 50 milliamper rating.
- One 82 tube and socket for same.
- One wooden case approximately 5x5x8.
- One bakelite cover for wooden case.
- One 500,000 ohm 1 watt fixed resistor.
- One 400,000 ohm 1 watt fixed resistor.
- One 250,000 ohm 1 watt variable resistor.
- One control knob for variable resistor.
- One instrument fuse base and clips.
- One instrument fuse, 2 amperes.
- Two tip plugs for leads (one red, one black)
- Two pin jacks (one red, one black)

First experiment with parts to find the most suitable arrangement of the different items in the case. Small sketch shows one method that has proved satisfactory. Tube base must be so placed as to permit replacement of defective tube without the removing other parts. All connections must be soldered.

After the unit has been constructed, test the D.C. voltage output with a 0-1 mil voltmeter. If the voltage is too high, use a lower resistance at X. A little experiment and adjustment will probably be necessary before the correct output voltage is obtained. The meter to be used in conjunction with this supply device must not require more than one milliamper to produce full scale deflection. Higher current drain will result in lowering the output voltage of the power supply; this will introduce errors in the readings taken when the unit is being used for insulation resistance tests.

WATTMETER AND WATTHOURMETER DIAGRAMS

INDICATING WATTMETER.

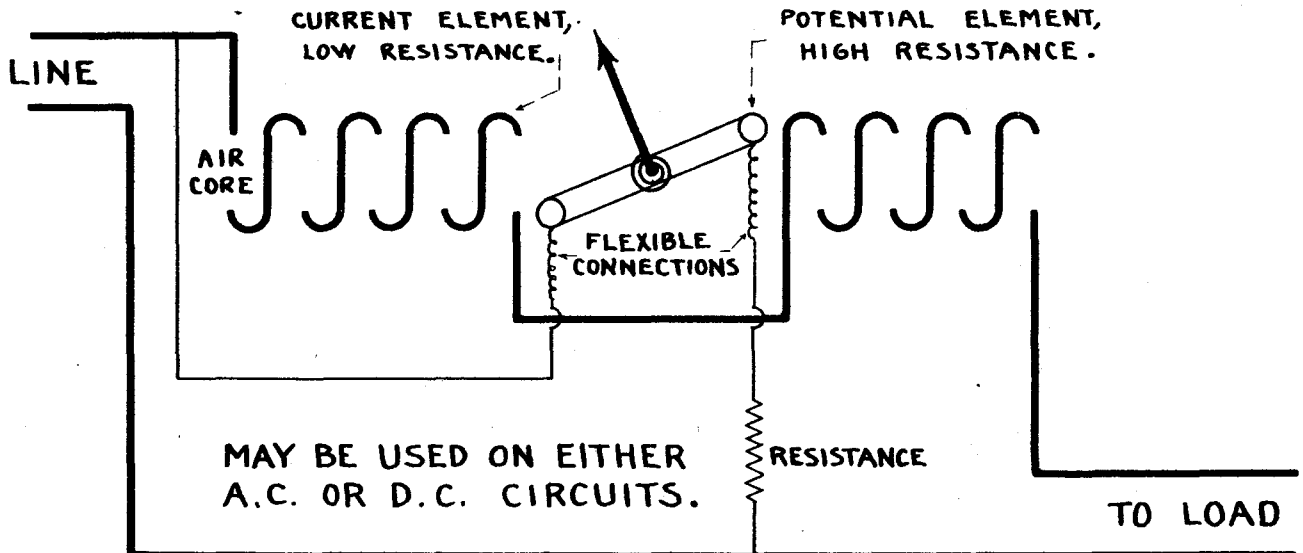

D.C. INTEGRATING WATTMETER.

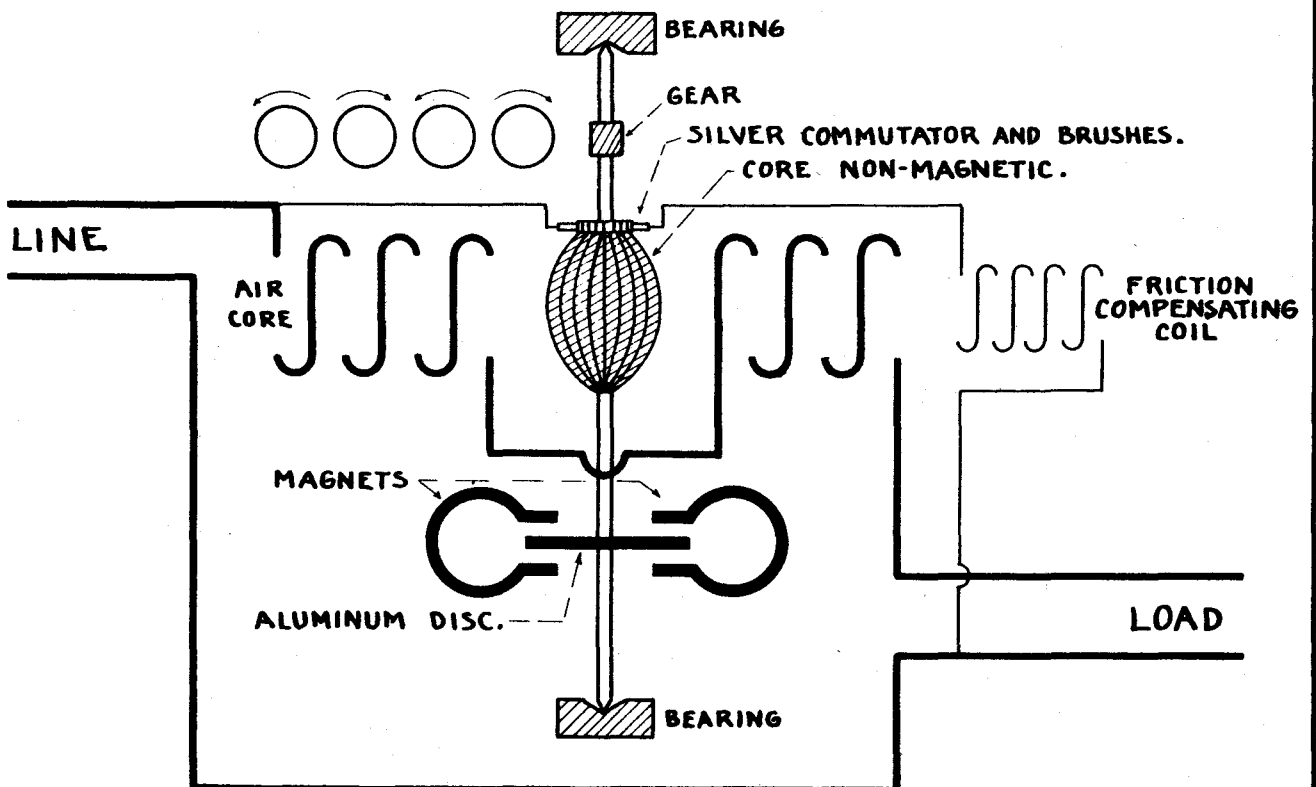



STANDARD LINE DIAGRAM SYMBOLS

CONTACTORS										KNIFE SWITCHES	AIR CIRCUIT BREAKERS	FUSE (POWER OR CONTROL CIRCUIT)			
MAIN CIRCUIT CONTACTS						AUXILIARY CIRCUIT CONTACTS		MECH-ANICAL INTER-LOCK	SINGLE POLE	SINGLE POLE	SINGLE POLE	MULTI POLE			
INSTANT. CLOSING			DELAYED CLOSING (DASHPOT TYPE)			N.O.	N.C.						MULTI POLE	MULTI POLE	MULTI POLE
WITH BLOWOUT	WITHOUT BLOWOUT		WITH BLOWOUT	WITHOUT BLOWOUT											
N.O.	N.C.		WITH BLOWOUT	WITHOUT BLOWOUT		N.O.	N.C.								
PUSH BUTTONS						LIMIT SWITCHES									
SINGLE CIRCUIT		DOUBLE CIRCUIT		MAIN-TAINED CONTACT	THREE POINT N.O.	N.O.		N.C.		MAINTAINED CONTACT SWITCHES	TER-MINALS ON TER-MINAL BLOCKS				
N.O.	N.C.	N.O.	N.C.			INITIALLY-OPEN		INITIALLY-CLOSED							
OVERLOAD RELAY CONTACTS				TIMING RELAY CONTACTS				MAINTAINED CONTACT SWITCHES		TER-MINALS ON TER-MINAL BLOCKS					
THERMAL	MAGNETIC				DASHPOT OR PNEUMATIC				SINGLE THROW		DOUBLE THROW				
	DASHPOT (DELAYED TRIP)		INSTANT. TRIP		ACTION RETARDED WHEN COIL IS -										
	N.C.	N.O.	N.C.	N.O.	ENERGIZED		DE-ENERGIZED								
MISCELLANEOUS															
PLUG (ZERO SPEED) SWITCH	SEPAR-ABLE CON-NECTOR	TEST JACK	METER	LIGHTS		FLOAT SWITCH		PRESSURE OR VACUUM SWITCH		BATTERY (STORAGE OR PRIMARY)	CON-DENSER	BELL			
				SIGNAL	INCANDESCENT	N.O.	N.C.	N.O.	N.C.						
COILS															
CONTACTOR - RELAY					MISCELLANEOUS										
SHUNT	SERIES	THERMAL	SOLENOID	REACTOR	TRANSFORMERS			RESISTORS			METER SHUNT				
					AUTO.	POTENTIAL	CURRENT	FIXED	TAPPED	RHEOSTAT					
								(DENOTE PURPOSE)							

1748-C3

Direct-Current Control Circuits

EASE IN SHOOTING TROUBLE on d.c. controls depends largely on a clear understanding of the basic principles and circuits used. It is the purpose of these data sheets to give that information.

In general, d.c. motors of less than 2-hp. rating can be started across the line, but with larger motors it is usually necessary to put resistance in series with the armature when it is connected to the line. This resistance, which reduces the initial starting current to a point where the motor can commute successfully, is shorted out in steps as the motor comes up to speed and the

countervoltage generated is sufficient to limit the current peaks to a suitable value. Accelerating contactors that short out successive steps of starting resistance may be controlled by countervoltage or by definite-time relays.

For small motors used on auxiliary devices the counter-c.m.f. starter is satisfactory. The definite time starter is more widely used, however, and has the advantage of being independent of load conditions.

The following diagrams illustrate some of the circuits commonly used for d.c. motor control.

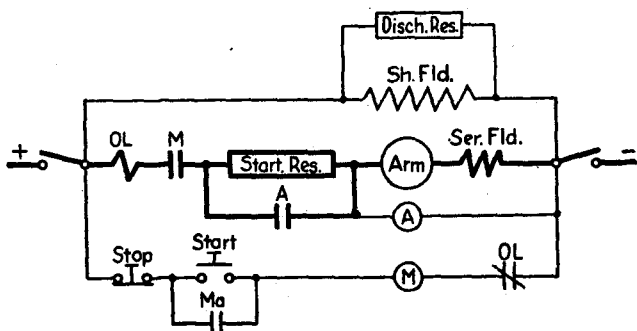

Figure 1. Basic requirements of a non-reversing d.c. starter in its simplest form.

When the start pushbutton is depressed line contactor M closes, energizing the motor armature through the starting resistance. As the motor comes up to speed the countervoltage, and the voltage across motor armature and series field, increases. At a predetermined value the accelerating contactor A closes, shorting out the starting resistance.

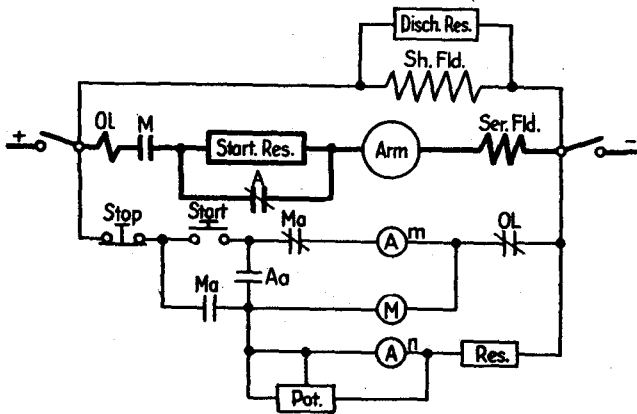

Figure 2. Typical, non-reversing constant-speed, definite-time starter. The accelerating contactor is equipped with a time-delay mechanism. This contactor, A, is of the magnetic-flux-decay type. It is spring-closed, equipped with two coils, and has a magnetic circuit that retains enough magnetism to hold the contactor armature closed and the contact open indefinitely. Main coil Am has sufficient pull to pick

up the armature and produce permanent magnetization. Neutralizing coil An is connected for polarity opposite to the main coil. It is not strong enough to affect the pick-up or holding ability of the main coil but, when the latter is deenergized, the neutralizing coil will buck the residual magnetism so that the contactor armature is released by the spring and the contacts close. By adjusting the potentiometer the voltage impressed on this coil and hence the time required for the contactor to drop out can be varied. When the start button is depressed accelerating contactor coil Am is energized, causing contact A to open and auxiliary contact Aa to close. Contact Aa energizes line contactor M, and normally open auxiliary contacts Ma establish a holding circuit. Neutralizing coil An is also energized. Opening of contact Ma deenergizes coil Am and contactor A starts timing. At the set time the main normally closed contacts on A close, shorting out the starting resistance and putting the motor across the line.

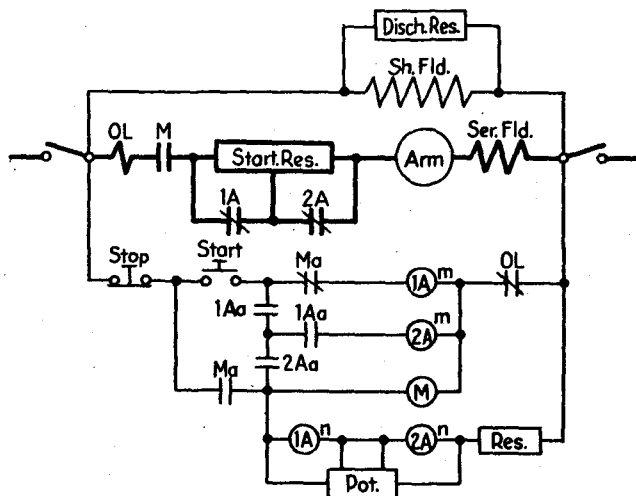

Figure 3. The same kind of a starter as in Figure 2 but designed for use with a motor of larger horsepower.

This starter provides two steps of definite-time starting. The operation is essentially the same as in Figure 2 but the first accelerating contactor, 1A, does not short out all the starting resistance. It also starts 2A timing, which finally

shorts out the remaining resistance. The normally open auxiliary contacts on the accelerating contactors in Figures 2 and 3 are arranged so that it is necessary for the accelerators to pick up before the line contactor can be energized. This is a safety interlocking scheme that prevents starting the motor across the line, if the accelerating contactors are not functioning properly.

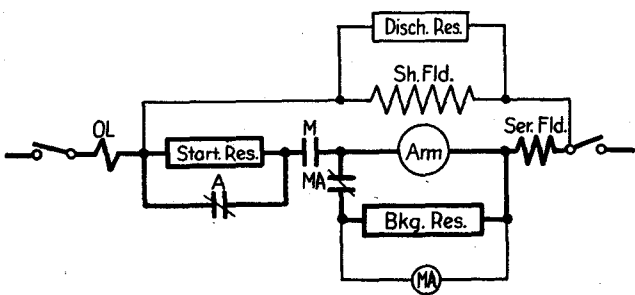

Figure 4. One way of producing dynamic braking. Control circuits have been omitted, since they are a duplicate of those shown in Figures 2 and 3. Line contactor M has two poles, one normally open and the other normally closed. Both poles are equipped with an operating coil and are on the same armature, which is hinged between the contacts. In starting, when line contactor M closes normally closed contact MA opens. When the stop button is depressed the line contactor drops out and contact MA closes. The motor, now acting as a generator, is connected to the braking resistor and coil MA is energized by the resultant voltage. It causes M to seal in tightly, establishing good contact pressure and preventing this contact from bouncing open.

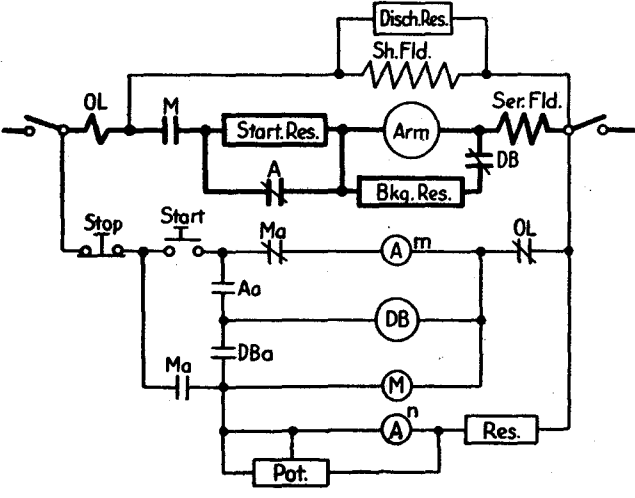

Figure 5. In the more modern types of controllers a separate spring-closed contactor is used for dynamic braking. Operation is similar to that described for Figure 2, except that the energizing of coil Am and the picking up of accelerating contactor A, closing contact Aa, energizes dynamic braking contactor DB, which in turn energizes line contactor M through its auxiliary contact, DBa. This arrangement not only insures that the dynamic braking contactor is open, but also that it is open before the line contactor can

close. In order to obtain accurate inching, such as is required for most machine tool drives, the motor must respond instantly to the operation of the pushbutton. In the scheme shown in Figure 5 the closing of the line contactor is delayed until the accelerating contactor and the dynamic braking contactor pick up.

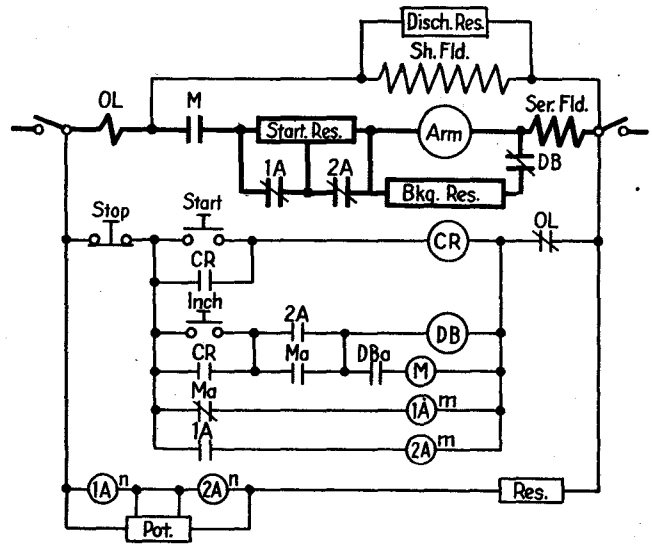

Figure 6. Arrangement to secure quicker response of motor, for more accurate inching. Accelerating contactors 1A and 2A are energized in the off position. Hence, when the start button is depressed, the dynamic braking contactor picks up immediately and its auxiliary contact DBa picks up M line contactor.

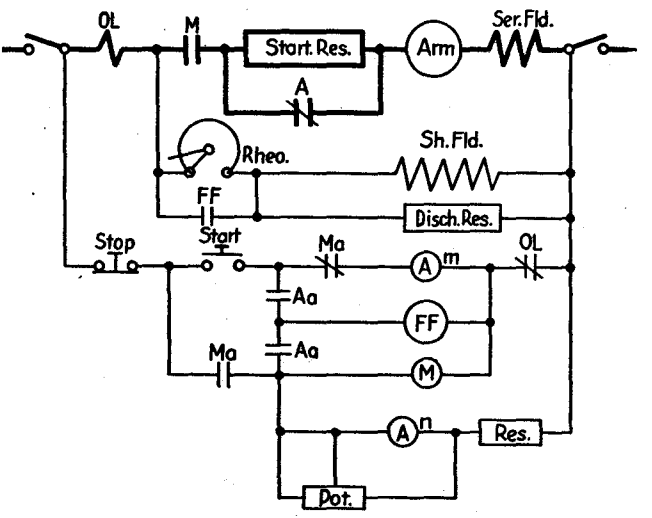

Figure 7. One method of connecting full field relay, used with adjustable-speed motors having a speed range in excess of 2 to 1. Coil FF is energized by the closing of the normally open auxiliary contact Aa and remains closed until the last accelerating contactor drops out. Contacts of the full field relay, FF, are connected to short out the field rheostat thereby applying maximum field strength to the motor during the starting period.

Direct-Current Control Circuits

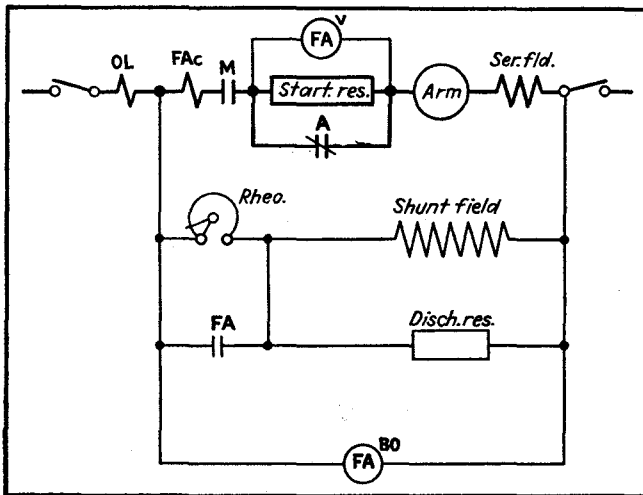

Figure 8. Another method of applying the full-field relay.

This arrangement insures full field on starting, and provides for limiting the armature current when the motor is accelerating from the full-field speed to the speed set by the rheostat. Field accelerating relay FA is equipped with two coils, one a voltage coil connected across the starting resistance, the other a current coil connected in series with the motor armature. See Figure 2 for the remainder of the circuit. When line contactor M closes the voltage drop across the starting resistor is practically line voltage, and relay FA is picked up quickly. When accelerating contactor A closes, voltage coil FAv is shorted, but closing of A produces a second current peak, and current coil FAC holds relay FA closed. As motor approaches full-field speed this current decays and allows the FA contacts to open, weakening the motor field. When the motor attempts to accelerate the line current again increases. If it exceeds the pick-up value of coil FAC the relay will close its contacts, arresting acceleration and causing a decay of line current, which again causes FA to drop out. High inductance of the motor field, plus inertia of the motor and drive prevent rapid changes in speed. Hence the motor will not reduce its speed, but the increased field current will reduce the armature current and cause FA to drop out. The fluttering action will continue until the motor reaches the speed set by the rheostat. Setting of the FA relay current coil determines the maximum current draw during this part of the acceleration period. Since relay FA must handle the highly inductive field circuit, a good blowout arrangement is necessary. Hence the relay is usually equipped with a shunt blowout coil, FABo.

Figure 9. Connections of field loss relay, to prevent excessive speed if the shunt field is deenergized while voltage remains on the armature.

It usually consists of a current relay in series with the motor shunt field and is adjusted to pick up on full-field current and remain closed at any current within the operating range of the motor field current. Contacts of relay FL

are connected in series with the overload relay contacts so that the opening of its contacts will deenergize the control by opening the line contactor. This type of field loss protection does not protect against the possibility of a short

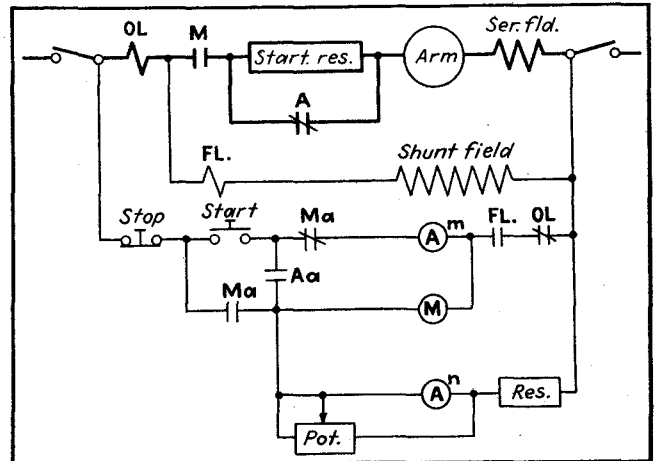

circuit across a part of the field, say across the one field coil. This would cause the motor speed to rise considerably but the current in the field circuit would also rise. Consequently, the series current relay would not respond.

Figure 10. Application of differential field loss protection.

The differential field loss relay DFL is equipped with two voltage coils connected to buck each other. Each is connected across one-half of the field winding. Normally the voltage across each coil is the same, hence the relay stays in the out position with its normally closed contacts closed. Shorting out of one field coil or other failure causing an un-

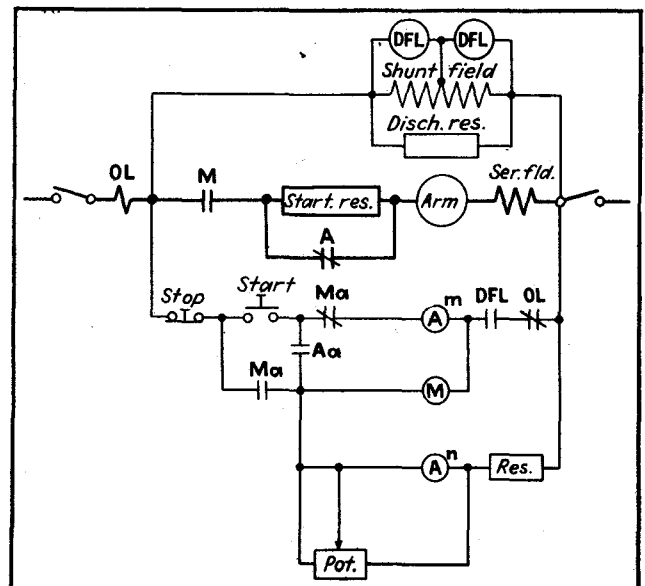

Direct-Current Control Circuits

balance of these voltages causes the relay to pick up, opening its contacts and dropping out the line contactor, deenergizing the motor.

Figure 11. One form of reversing dynamic braking control, consisting of multi-pole contactors having two poles normally open and one pole normally closed. Accelerating contactors 1A and 2A are energized in the off position, as in Figure 6. Depressing the forward button energizes forward contactor *F*, closing the two normally open contacts *F* and opening the normally closed contact *FA*. Opening of normally closed auxiliary contact *Fa* starts the timing cycle of the accelerating contactors. Closing of the normally open auxiliary contact *Fa* establishes a holding circuit. When the stop or reverse button is depressed contactor *F* drops out, closing normally closed contact *FA* and setting up a dynamic braking circuit through the braking resistors, which energizes coils *FA* and *RA*. These coils hold the normally closed contact closed, and the normally open contacts open until the braking current drops to a low value. This action prevents bouncing of the back contacts and plugging the motor, because if the reverse button were depressed during the braking period contactor coil *R* would not have sufficient strength to overcome the pull of the *RA* coil until the motor had almost stopped.

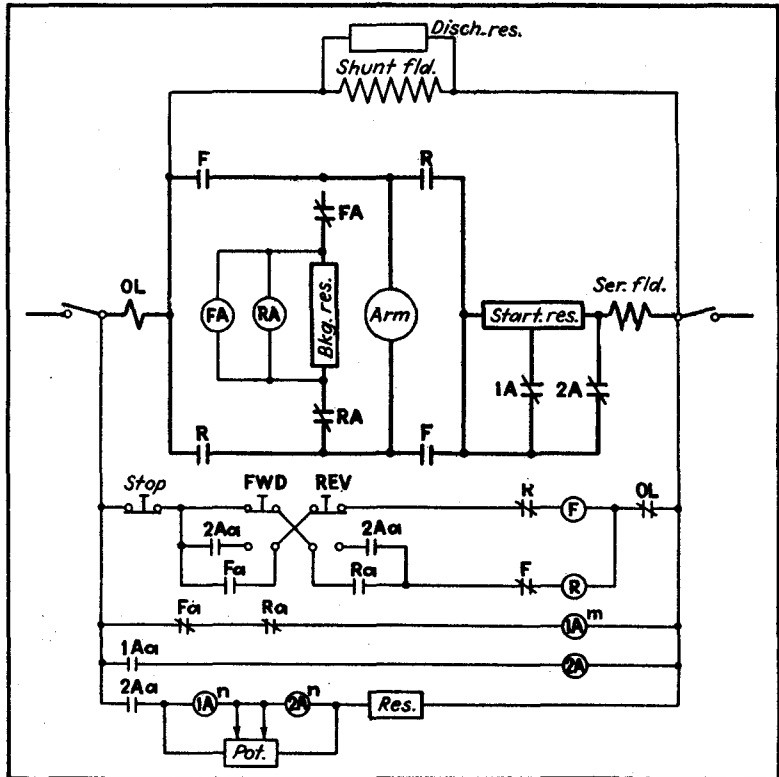
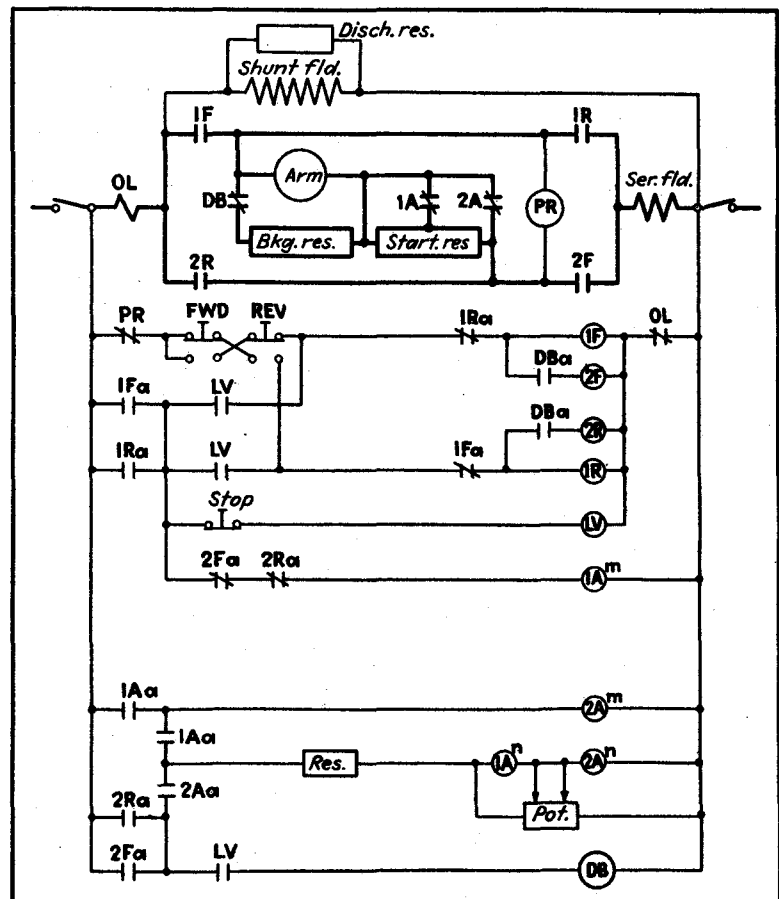

Figure 12. Another form of reversing dynamic braking starter using a spring-closed dynamic braking contactor and single-pole normally open directional contactors. When start button is depressed contactor *IF* is energized. Closing the normally open auxiliary contact *IFa* energizes relay *LV* to establish a holding circuit and also energizes accelerating contact *1A*; *1A* contactor energizes *2A*, and *2A* energizes *DB*. In turn, *DBa* energizes *2F* and normally closed contact *2Fa* starts the accelerating timing.

Depressing the stop button drops out *LV*, closing *DB* immediately. Plugging is prevented by relay *PR*, a voltage relay connected across the motor armature. Its normally closed contacts remain open, preventing the pick up of the reverse directional contacts until the armature speed drops down to a safe value for plugging.



STARTING AND CONTROLLING THE SPEED OF D. C. MOTORS

Small D.C. motors (fractional H.P.) may be started across the line. The resistance of the armature winding is high in comparison to the resistance of larger armatures. Large armatures have low resistance because heavy wire is used to wind them.

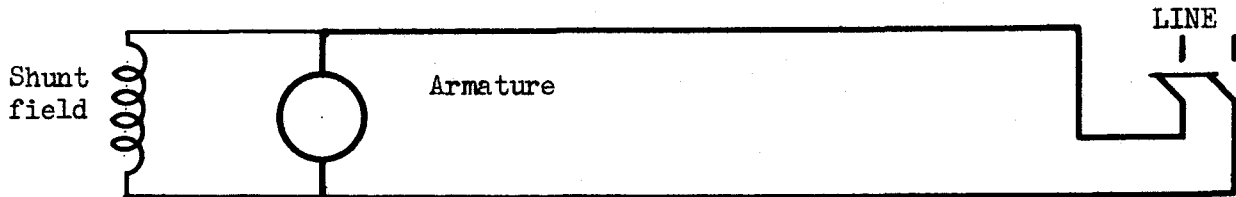

When starting a D.C. motor larger than fractional H.P. in size full line voltage should not be applied to the armature. A resistor should be connected in series with the armature to produce a voltage drop and apply a low voltage to the armature during the starting period. The starting period is from 10 to 45 seconds.

The starting current should be limited to $1\frac{1}{2}$ or 2 times full load current except when starting heavy torque loads which will require as much as 3 times full load current. After the motor attains normal speed the current through the armature can be determined by the formula; effective voltage divided by armature resistance. This value will be proportional to the mechanical load on the motor.

The shunt field must be connected so it will receive full line voltage when starting. The field must be maximum strength to produce good starting torque and for the armature to quickly generate CEMF.

FOUR POINT CONTROLLER

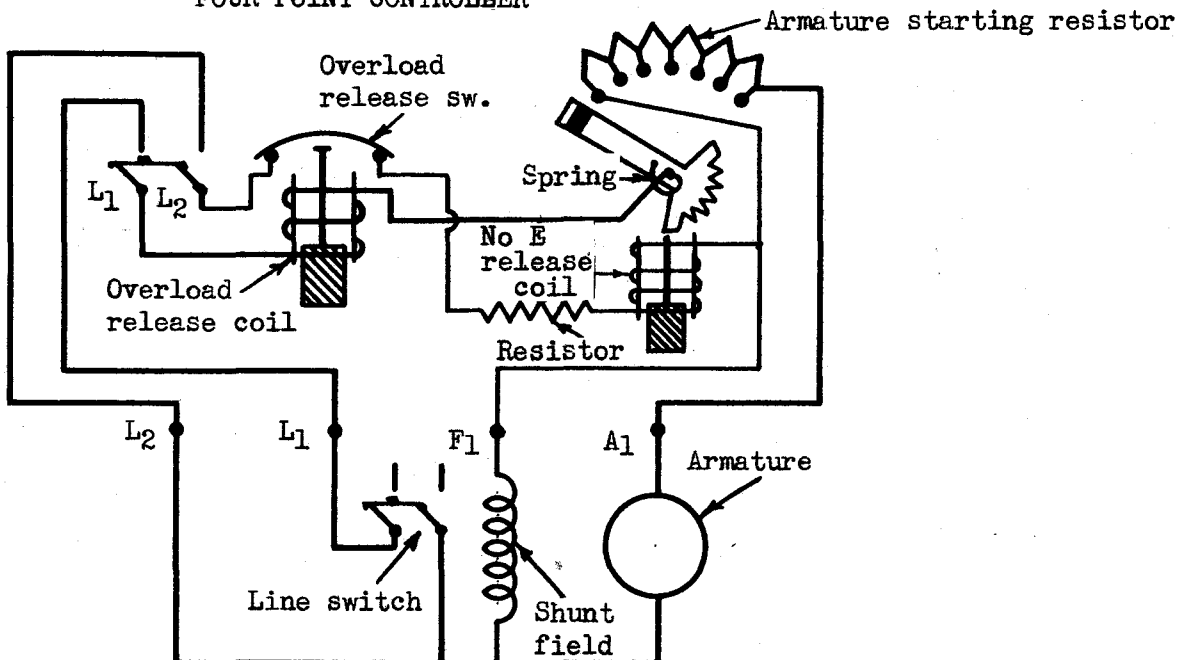

The NO VOLTAGE RELEASE COIL allows the spring on the power arm to return the power arm to the "off" position if the voltage on the line drops to a low or zero value.

OVERLOAD PROTECTION is provided by connecting an overload release coil in series with the load circuit. When the current reaches overload value the plunger will be drawn up and break the holding coil circuit. The spring on the power arm will return it to the off position.

The speed of a D.C. motor varies in direct proportion to the voltage applied to the armature and in inverse proportion to the strength of the field flux.

When a motor is operating with the rated voltage applied to the armature and field (with or without load) it is operating normally and the speed obtained is called NORMAL SPEED.

SPEED CONTROL BELOW NORMAL SPEED (armature control)

The speed can be controlled below normal by connecting a regulating resistor in series with the armature. The speed will vary with the voltage applied to the armature. The torque will not be affected because connecting a resistor in series with the armature does not change the amount of current through the armature. This value will be constant if the mechanical load is constant. The H.P. output will vary with the speed because the H.P. output is proportional to the speed and torque.

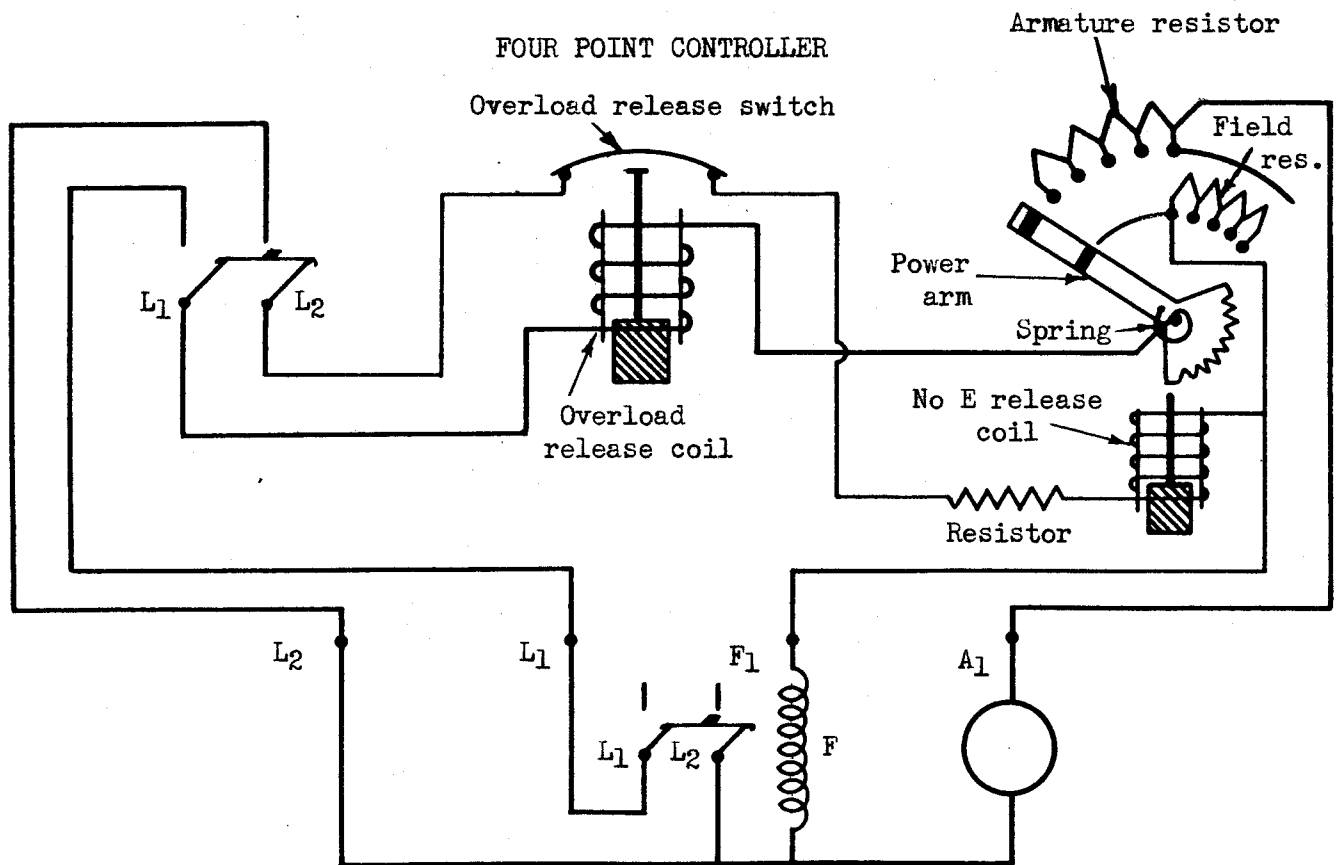

SPEED CONTROL ABOVE NORMAL SPEED (field control)

The speed can be controlled above normal on shunt and compound motors by connecting a shunt field rheostat in series with the shunt field. The speed will vary inversely with the field strength. Weakening the field will increase the speed because the armature must rotate faster to generate a sufficient amount of CEMF to limit the current through the armature in proportion to the mechanical load on the motor. Decreasing the field strength will decrease the torque. The H.P. output will not be affected because the H.P. output is always proportional to the speed and torque. When the speed increases and the torque decreases the product of the two will not change.

3 POINT STARTER DIAGRAMS

3 point starter for starting duty only.

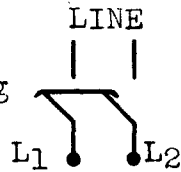

3 point starter for starting duty only. The overload release coil protects the motor against overloads.

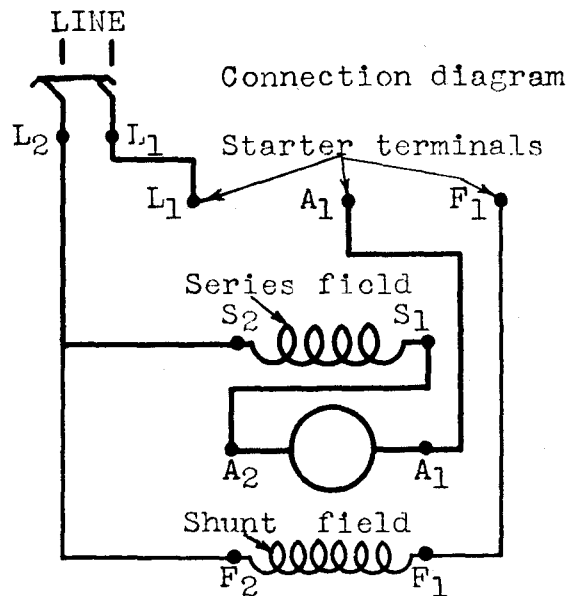
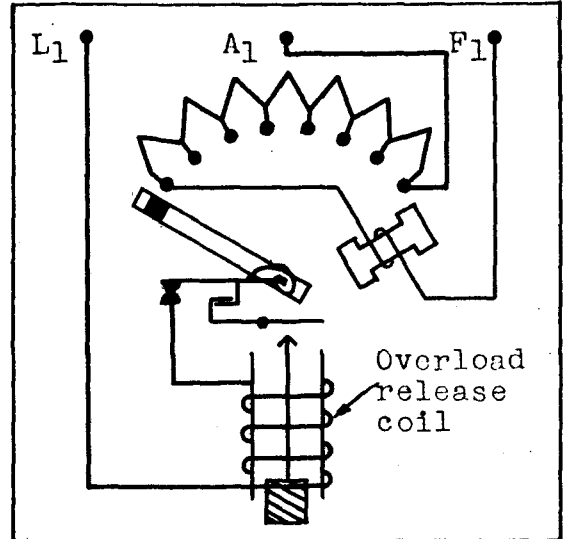
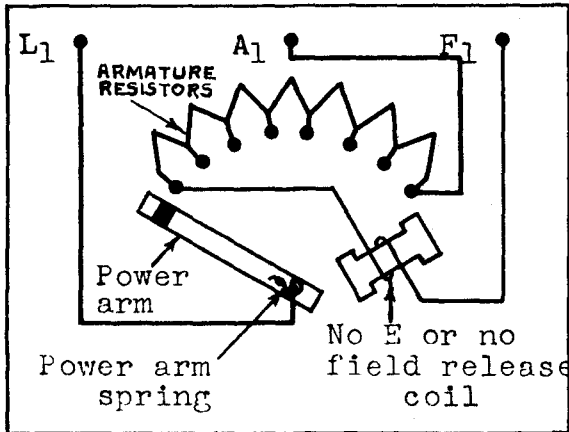

Connect as shown for compound motor.
For shunt motor connect A2 to L2.

Draw a detailed diagram of the motor. Show all parts such as field poles, brushes, armature, terminals and the position of the terminal board. Test the motor terminals with test lamp to identify them. Connect the motor to the starter as shown by the connection diagram.

19273D

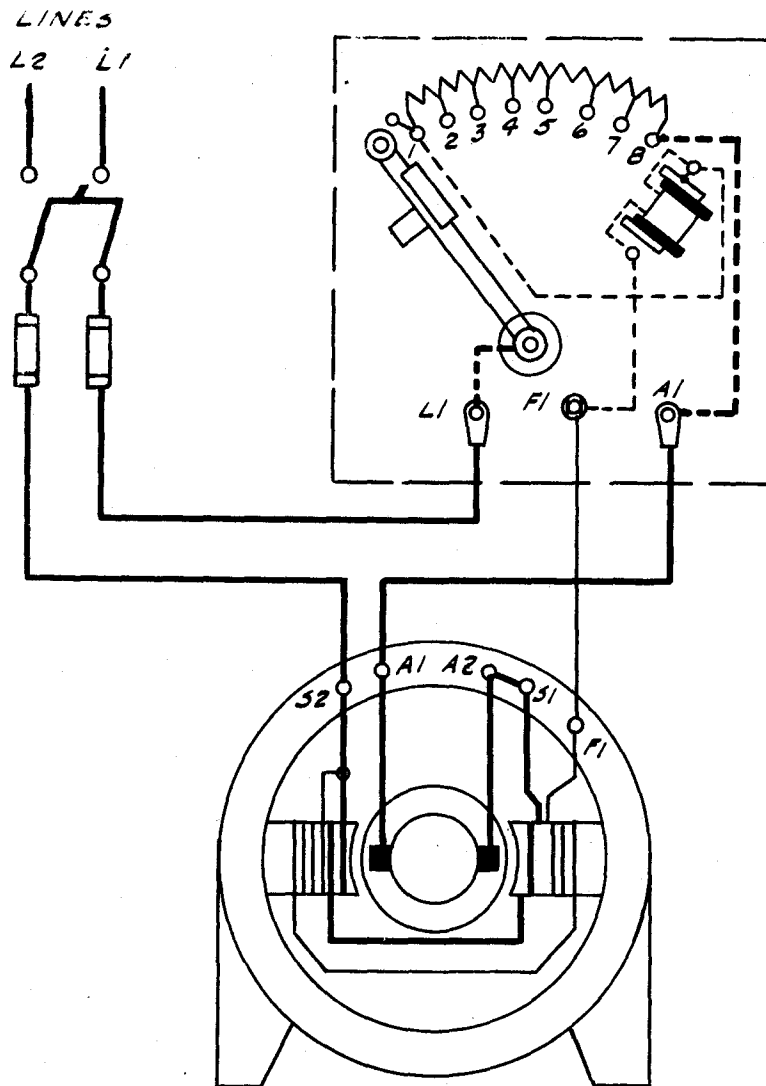

IF MOTOR IS SHUNT WOUND
TERMINALS "S1" AND "S2"
WILL BECOME COMMON

AN. SW. & FUSES CHANGED 3-9-30
J. J. 9-3-26 H.D.
BE MND

TITLE CONNECTIONS FOR DIRECT CURRENT MOTOR STARTING RHEOSTAT WITH LOW VOLTAGE PROTECTION.				TYPE "A"		SUP. NO.	
RETRACED BY <i>G. J. Griel</i>		TRACED BY LEO. M. ZEMAN		BULL NO. 2110 & 2111		SLIP BY NO.	
CHECKED BY <i>[Signature]</i>		APPROVED BY <i>A. D. [Signature]</i>		ORDER NO. STANDARD		19273D	
A	B	C	D				
CUTLER-HAMMER, INC. MILWAUKEE NEW YORK							

ORIGINAL TRACING FILED WITH PATENT DRAWINGS

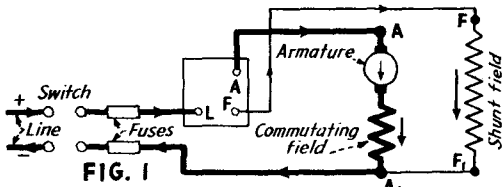

FIG. 3

FIG. 4

FIG. 5

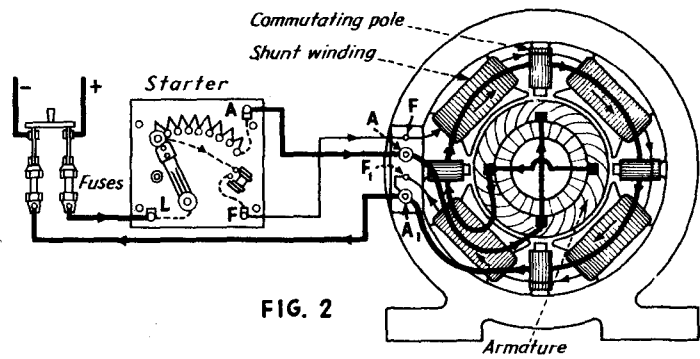
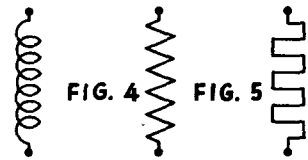

FIG. 2

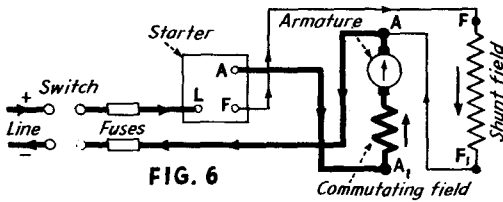

FIG. 6

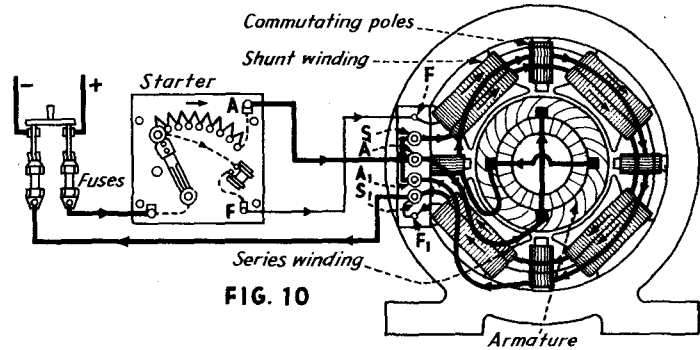

FIG. 10

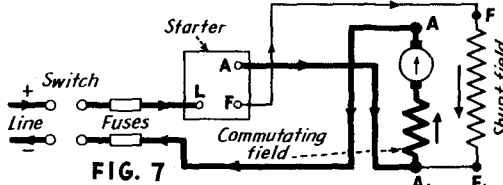

FIG. 7

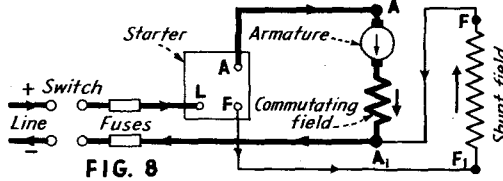

FIG. 8

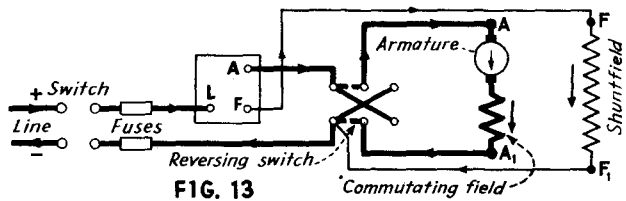

FIG. 13

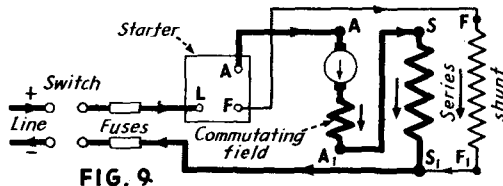

FIG. 9

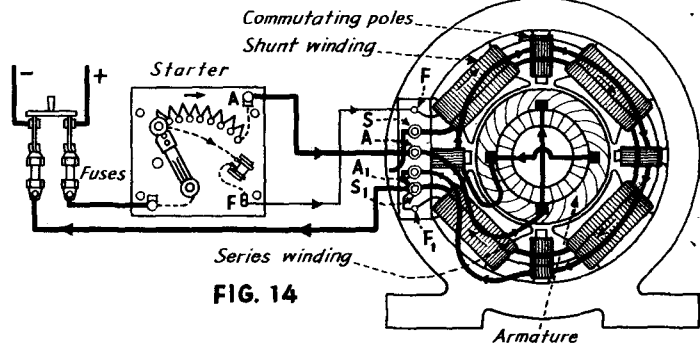

FIG. 14

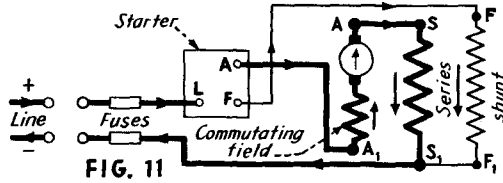

FIG. 11

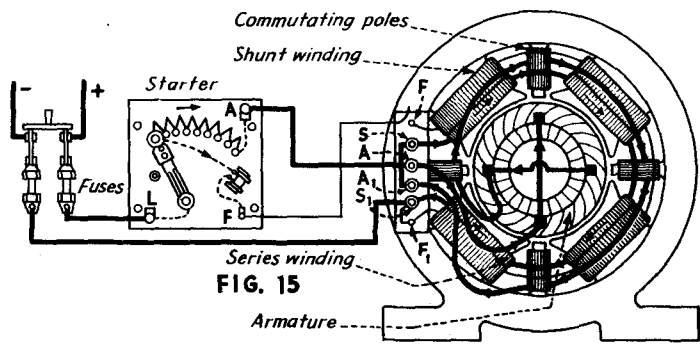

FIG. 15

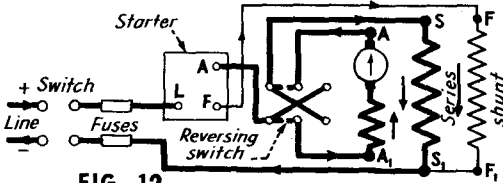
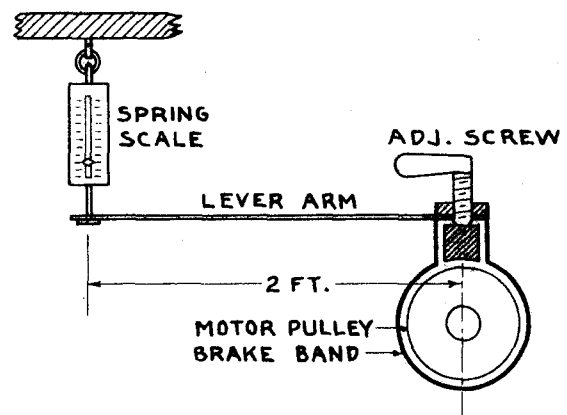
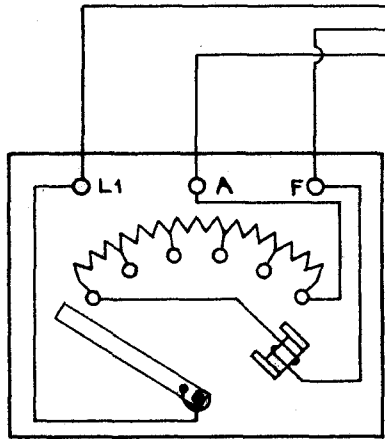
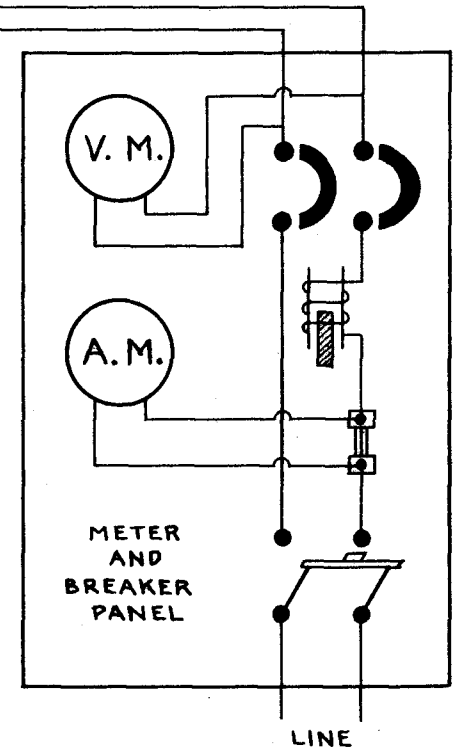
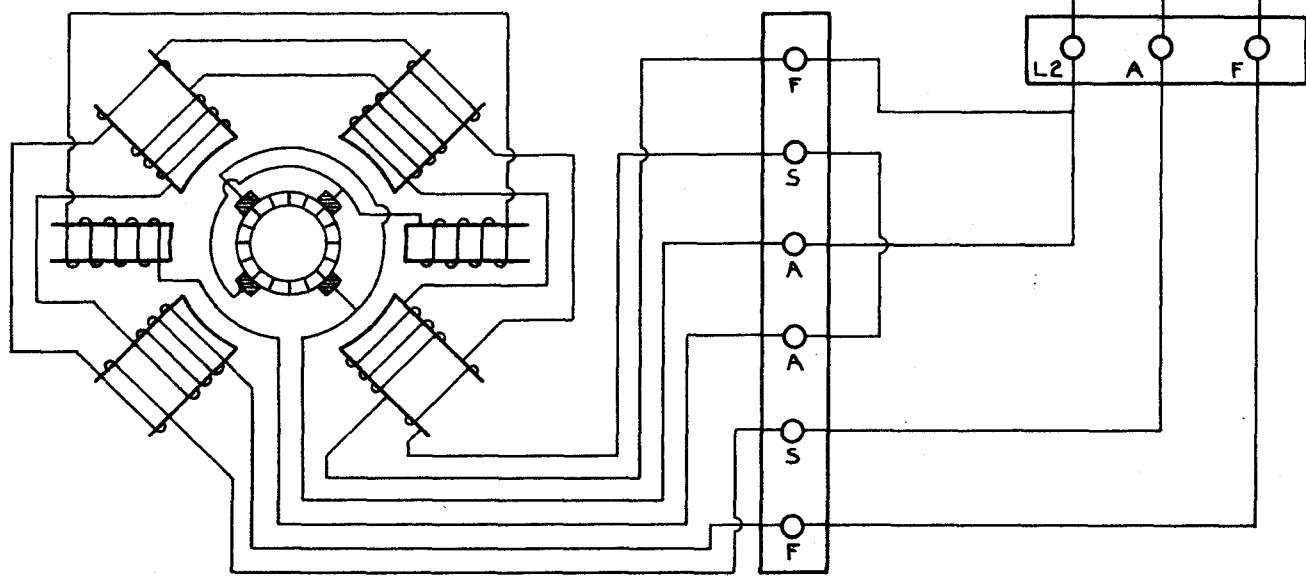

FIG. 12

Fig. 1—Diagram of shunt motor and starter, Fig. 2. Figs. 3 and 4—Symbols for coils. Figs. 4 and 5—Symbols for resistance. Fig. 6—Same as Fig. 1, but current reversed in armature circuits. Fig. 7—Wrong connection for reversing shunt motor. Fig. 8—Same as Fig. 1, except current is reversed in shunt field coils. Fig. 9—Diagram of compound motor and starter, Fig. 10. Fig. 12—Reversing switch connected in armature circuit of compound motor. Fig. 13—Reversing switch connected in armature circuit of shunt motor. Fig. 14—Series winding cut out of compound motor to test polarity of shunt-field coils. Fig. 15—Shunt winding cut out of compound motor to test polarity of series winding.



COMPUTE H.P. OUTPUT AND EFFICIENCY.
ALLOW 1/2 LB. FOR THE WEIGHT OF THE
LEVER ARM WHEN COMPUTING H.P. OUTPUT.



$$H.P. = \frac{2\pi \times P \times L \times R.P.M.}{33,000}$$

$$2\pi = 6.28$$

P = PULL ON LEVER IN LB.

L = LENGTH OF LEVER IN FT.

R.P.M = REVOLUTIONS PER MINUTE.

$$EFFICIENCY = \frac{WATT OUTPUT}{WATT INPUT}$$

D.C. POWER DEP'T.

INDUSTRIAL CONTROLLER
Starting duty only

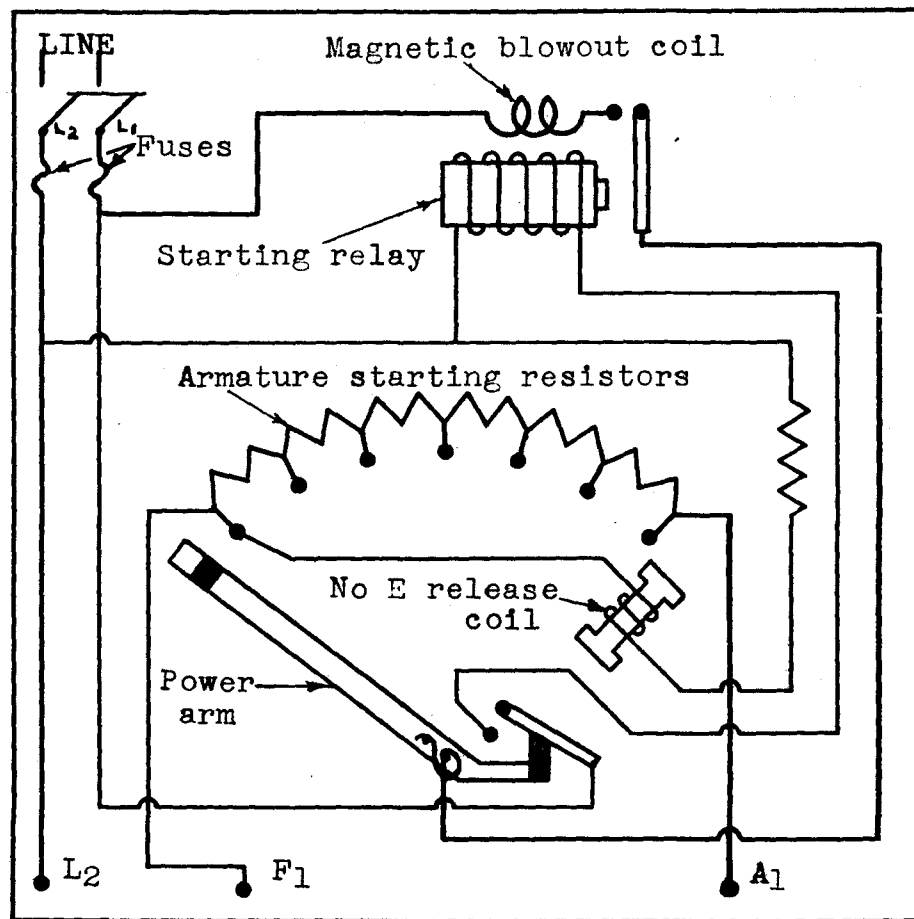

Draw a detailed diagram of the motor. Show all parts such as field poles, brushes, armature, terminals and the position of the terminal board. Test the motor terminals with test lamp to identify them.

Connect the motor to the controller as shown by the connection diagram. Trace the starting relay, field, armature and no E release coil circuits and have the diagram OKed by the instructor before wiring the job.

Connection Diagram

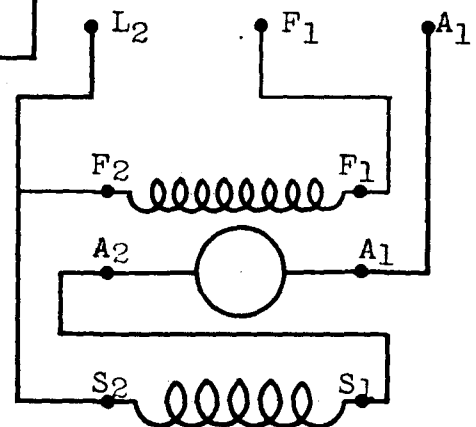

Connect as shown for compound motor.
For shunt motor connect A2 to L2

4 POINT CONTROLLERS

4 Point controller for starting & regulating duties.

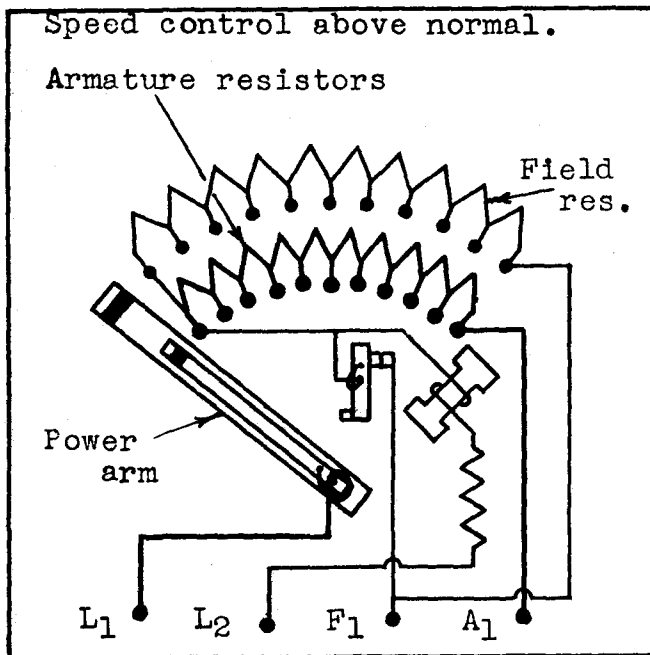

4 Point controller for starting & regulating duties.

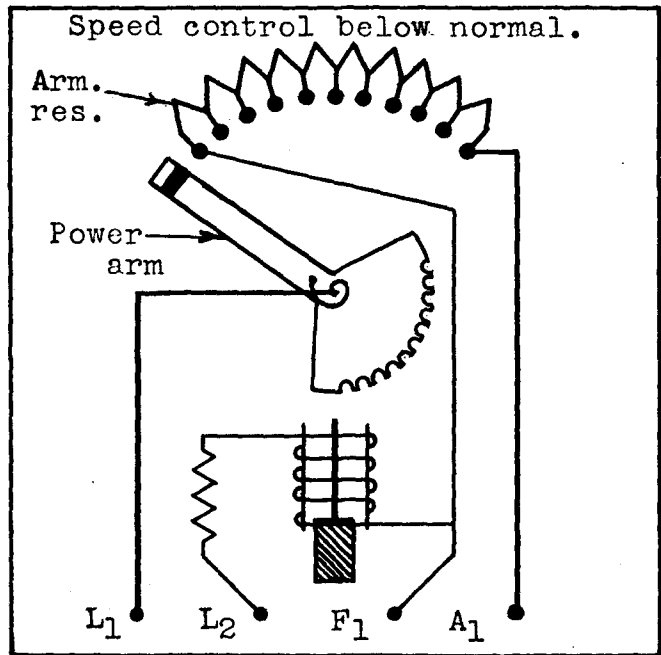

LINE



LINE

Connection diagram

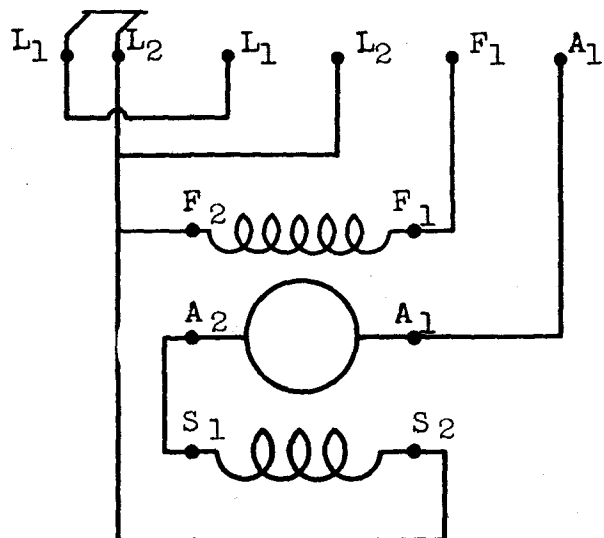

Connect as shown for compound motor. For shunt motor connect A₂ to L₂.

Draw diagram of motor in detail. Show all parts, such as, field poles, armature, brushes, terminal board and terminals. Test motor terminals to identify them. Trace armature, field and holding coil circuits. Have the diagram checked and OKed before wiring the job.

20311D

ORDER NO	NO. REQ'D	DEPARTMENT	RAW MAT. SPEC. WITH PART NO. & AMOUNT REQ'D
----------	-----------	------------	---

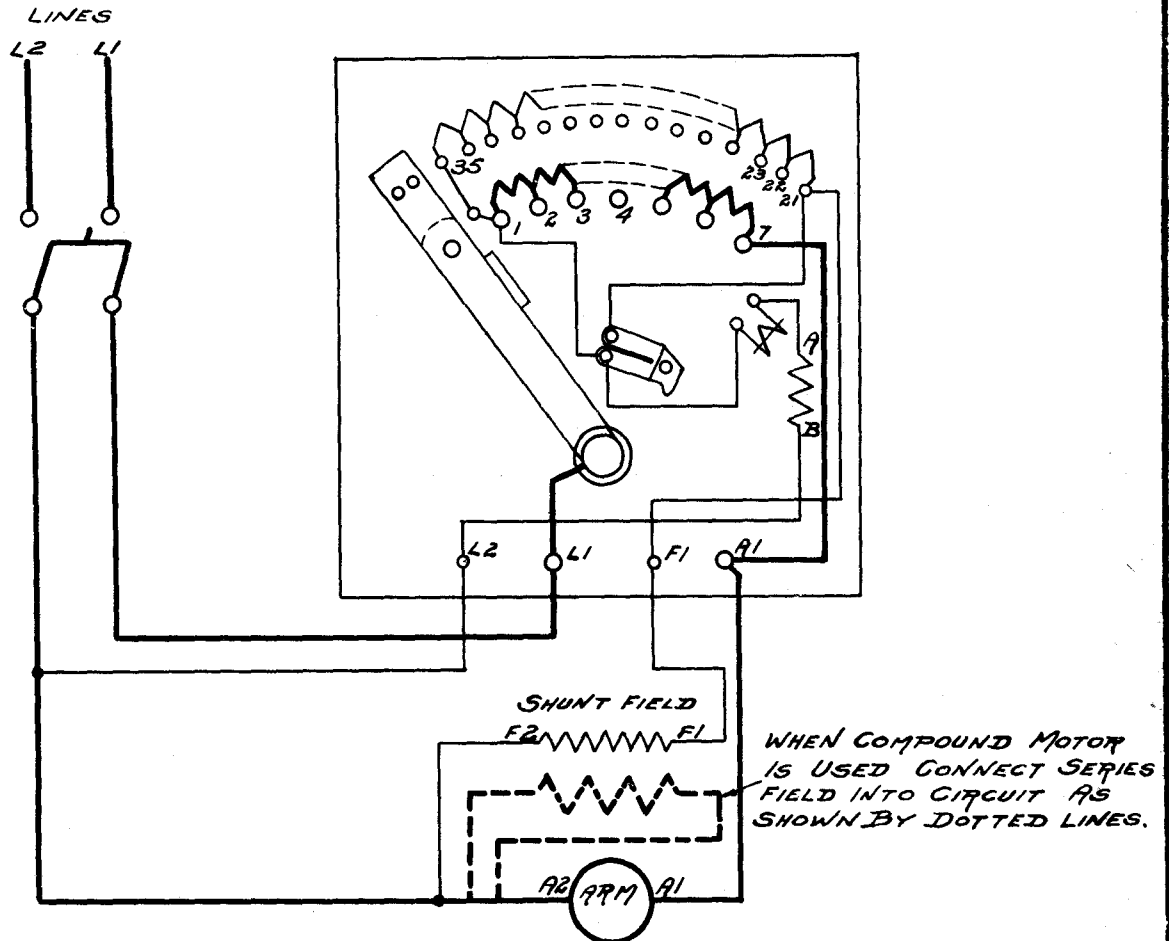

WHEN COMPOUND MOTOR IS USED CONNECT SERIES FIELD INTO CIRCUIT AS SHOWN BY DOTTED LINES.

BULL. No. 2230
 CLASS No. 74446
 TYPE A

STANDARD CONNECTIONS FOR COMPOUND MOTOR STARTER WITH NO VOLTAGE

NAME: RELEASE FOR SHUNT OR COMPOUND MOTOR

SUPERSEDES NO. T14163-D

A		D	
B		E	
C		F	

SCALE: DRAWN BY: CHECKED BY: H.R. HUTH APPROVED BY: H.R. HUTH

TOLERANCES ON ALL FRACTIONAL MACHINED DIMENSIONS TO BE ± .015
 TOLERANCES ON ALL DECIMAL DIMENSIONS TO BE ± .005 UNLESS OTHERWISE SPECIFIED.

20311D

THE CUTLER-HAMMER MFG. CO., MILWAUKEE, WIS.

FORM 357-07M. 35734

JOB NO. 15

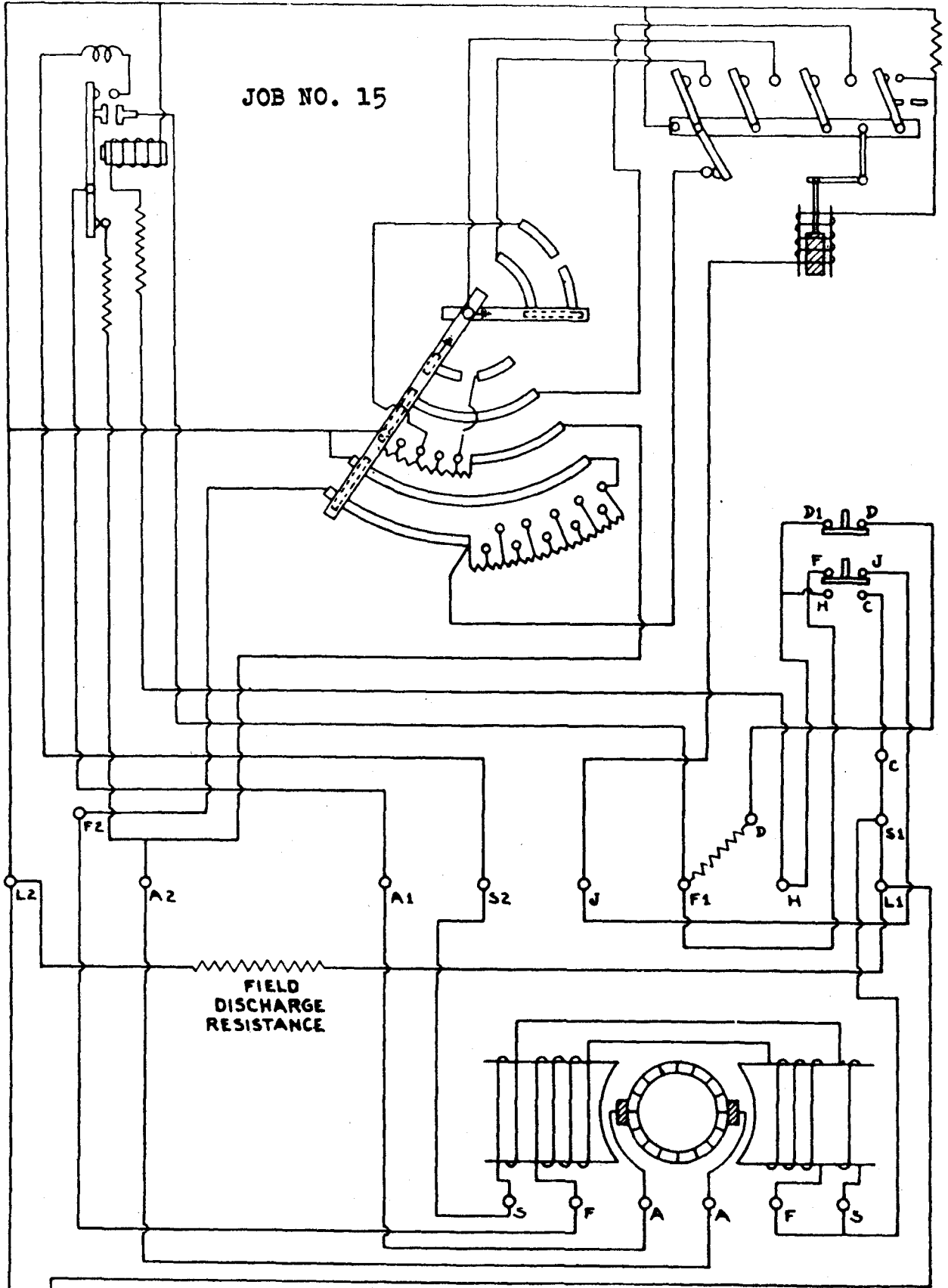

LINE

PRINTING PRESS CONTROLLER.

DRUM CONTROLLERS

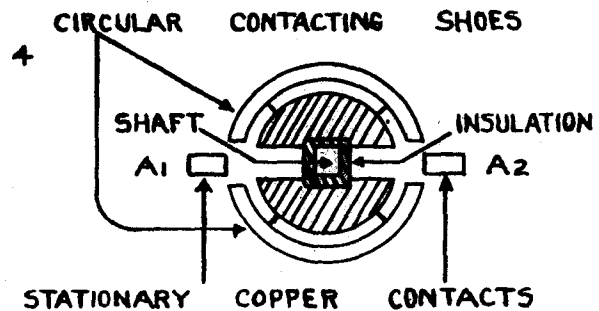
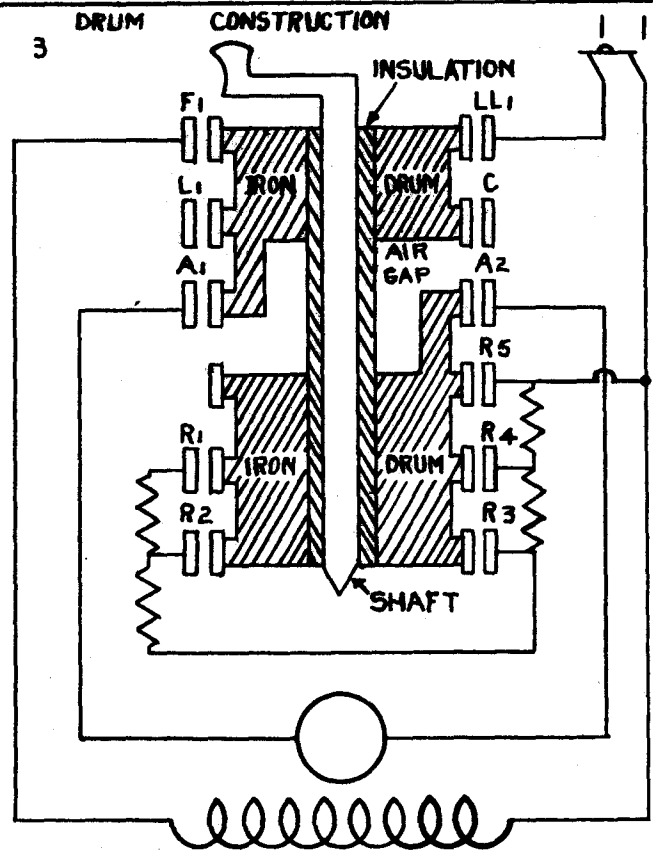
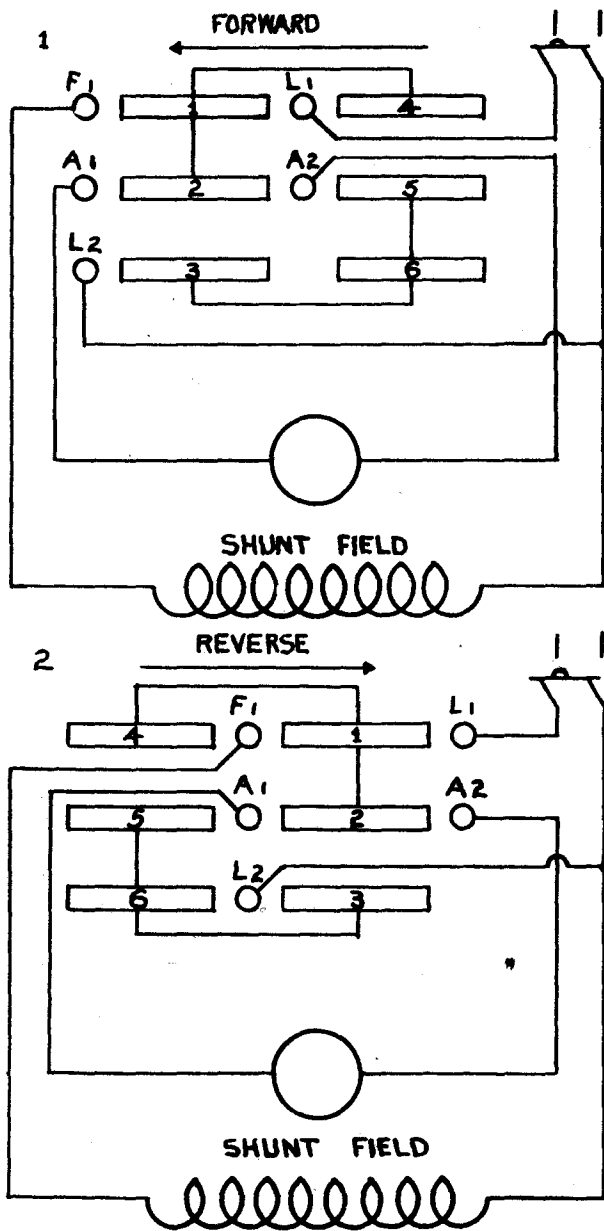

Drum controllers are used extensively in the operation of D.C. motors where they must be started, stopped, reversed, and have their speed varied, as on street cars, electric trains, hoists, cranes, etc.

The name is derived from their shape and the manner of mounting contacts on a round iron drum. The cylindrical arrangement of the contacts allows the drum to be rotated part of a revolution in either direction, and brings into connection one or more stationary contacts with the iron drum. The iron drum serves as a mechanical support for the shoes and forms a part of the conducting path.

A drum controller, designed for reversing duty, is divided into two parts, completely insulated from each other and from the shaft by fibre insulation.

When the controller in Fig. 2 is in running position, current will flow from positive line to stationary contact "L1" (Called "contact finger") and enter the iron drum at circular shoe #1, and then flows through the iron drum to shoe #2, which is connected to "A2", completing the circuit through the armature. The return circuit for the armature is from "A1" to Shoe #5, through iron drum to shoe #3, which is connected to "L2".

Drum controllers are very rugged and will give excellent service with a minimum of maintenance. The contact fingers and bars may be replaced when burned or worn. Drum controllers may be equipped with auxiliary contacts that close when the drum is in the "OFF" position. These contacts are used to complete a dynamic brake circuit or to operate relays for overload protection.

DRUM CONTROLLER WITH OVERLOAD PANEL

This diagram illustrates how an overload panel is used to protect the motor against overload and "no voltage" conditions, by using contacts "L1" and "C" to complete the relay circuit when the controller is in the "off" position.

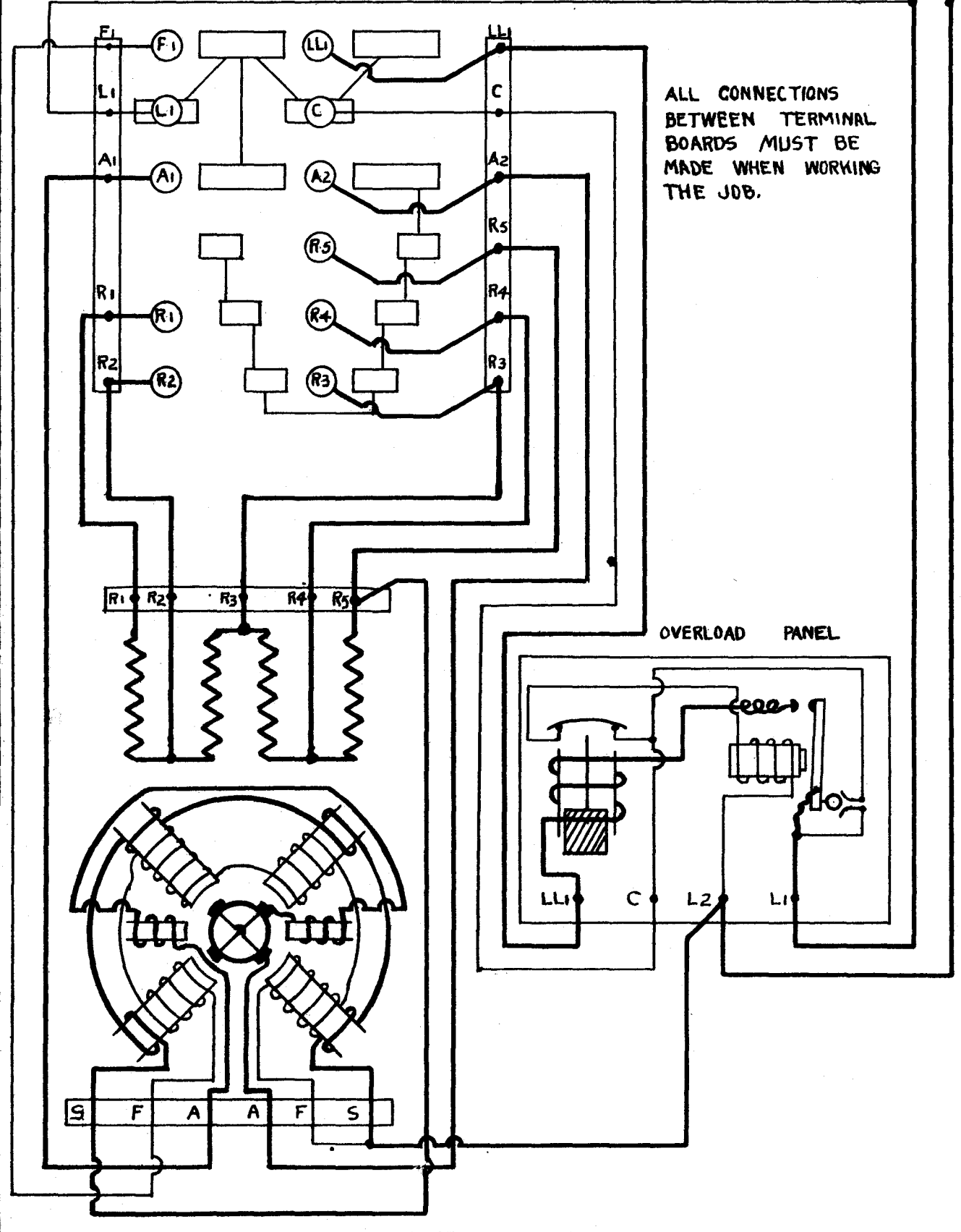

DRUM CONTROLLER & SERIES MOTORS.

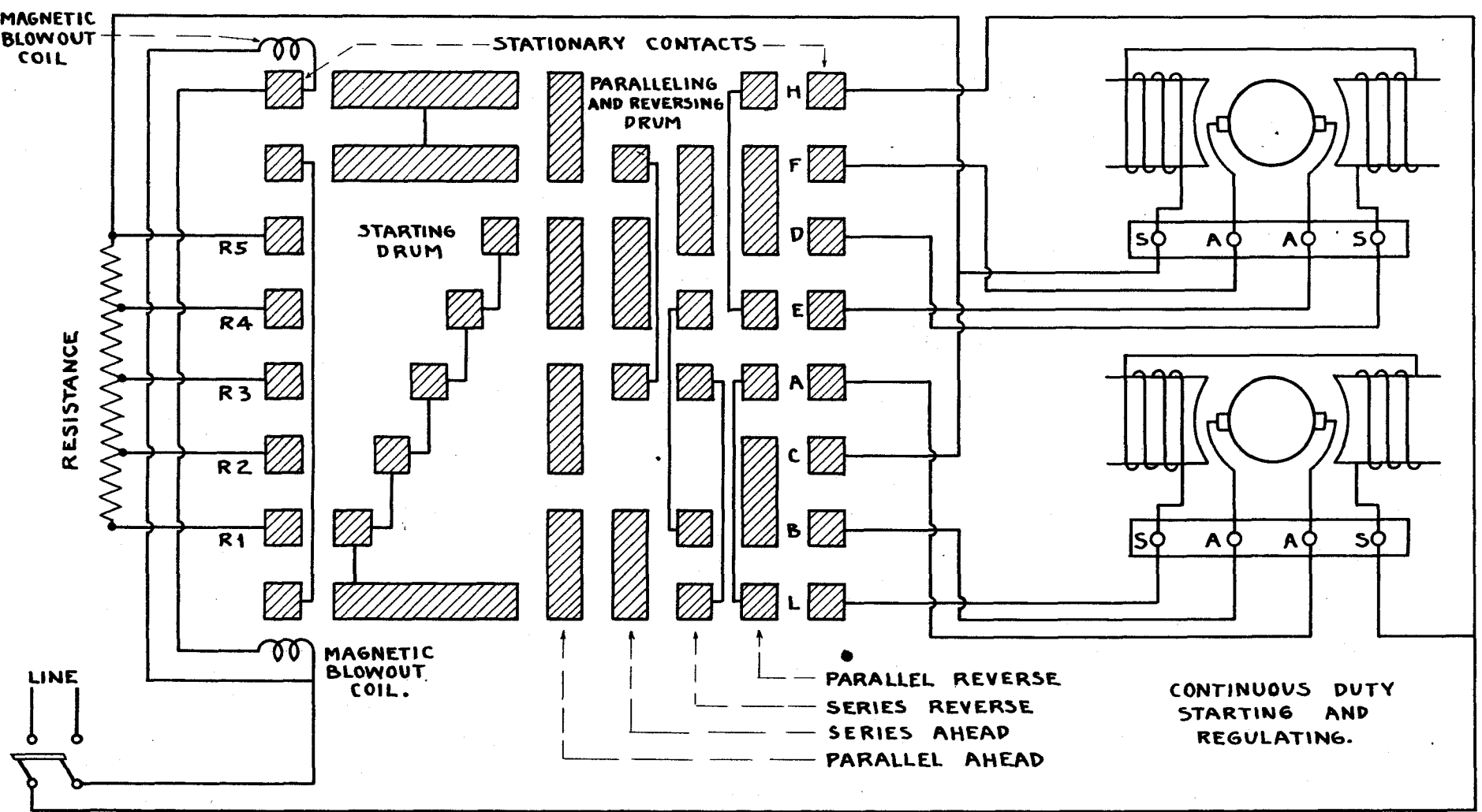

Drum controller for starting, regulating and reversing duties.

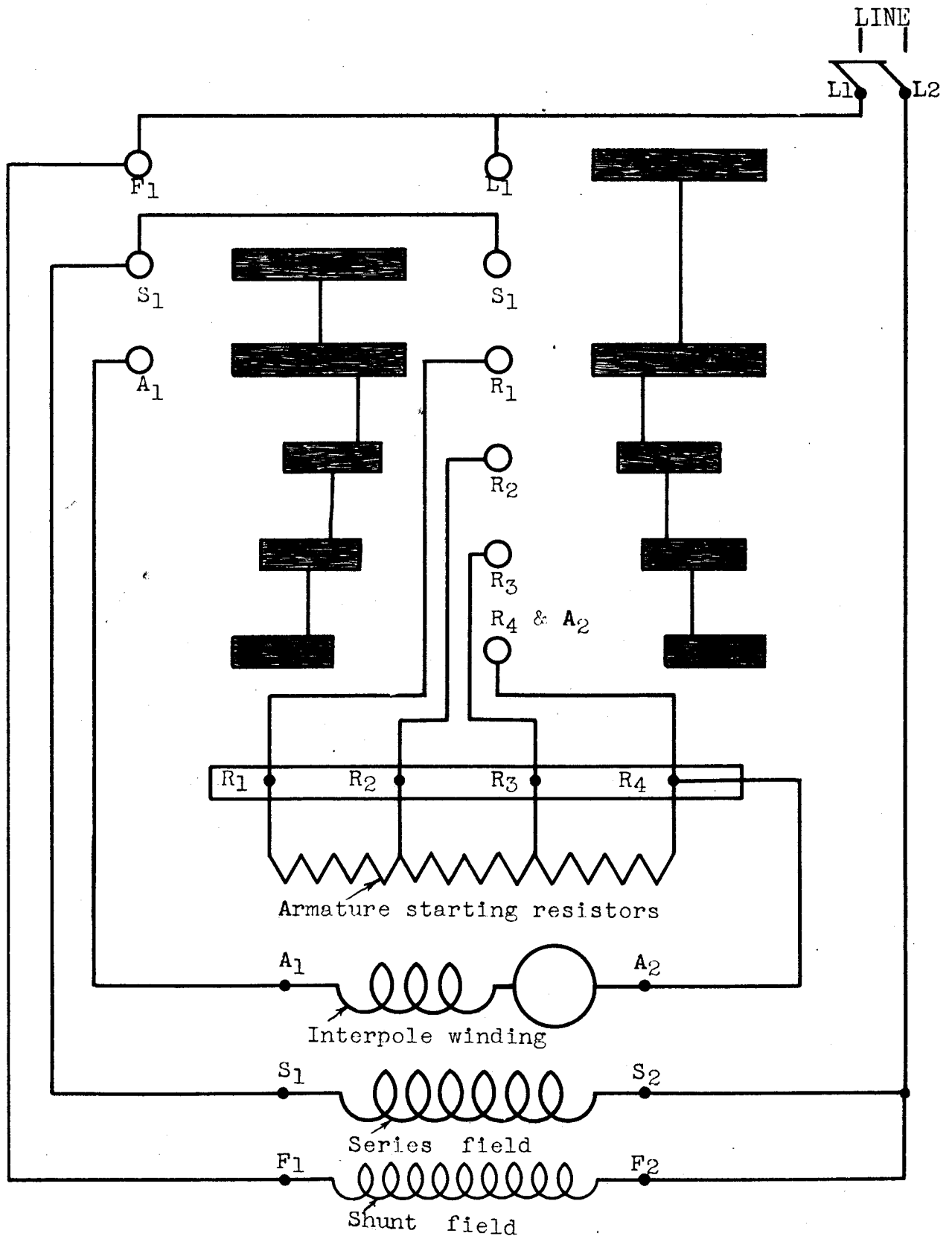

Trace forward armature, reverse armature and field circuits. Draw the terminal board on the diagram and test and identify the terminals. Do not show the terminals connected. Make all connections as shown if a compound motor is used. If shunt motor is used connect S₁ to L₂. If series motor is used omit F₁ connection.

COYNE

DRUM CONTROLLER
STARTING, REGULATING & REVERSING DUTIES

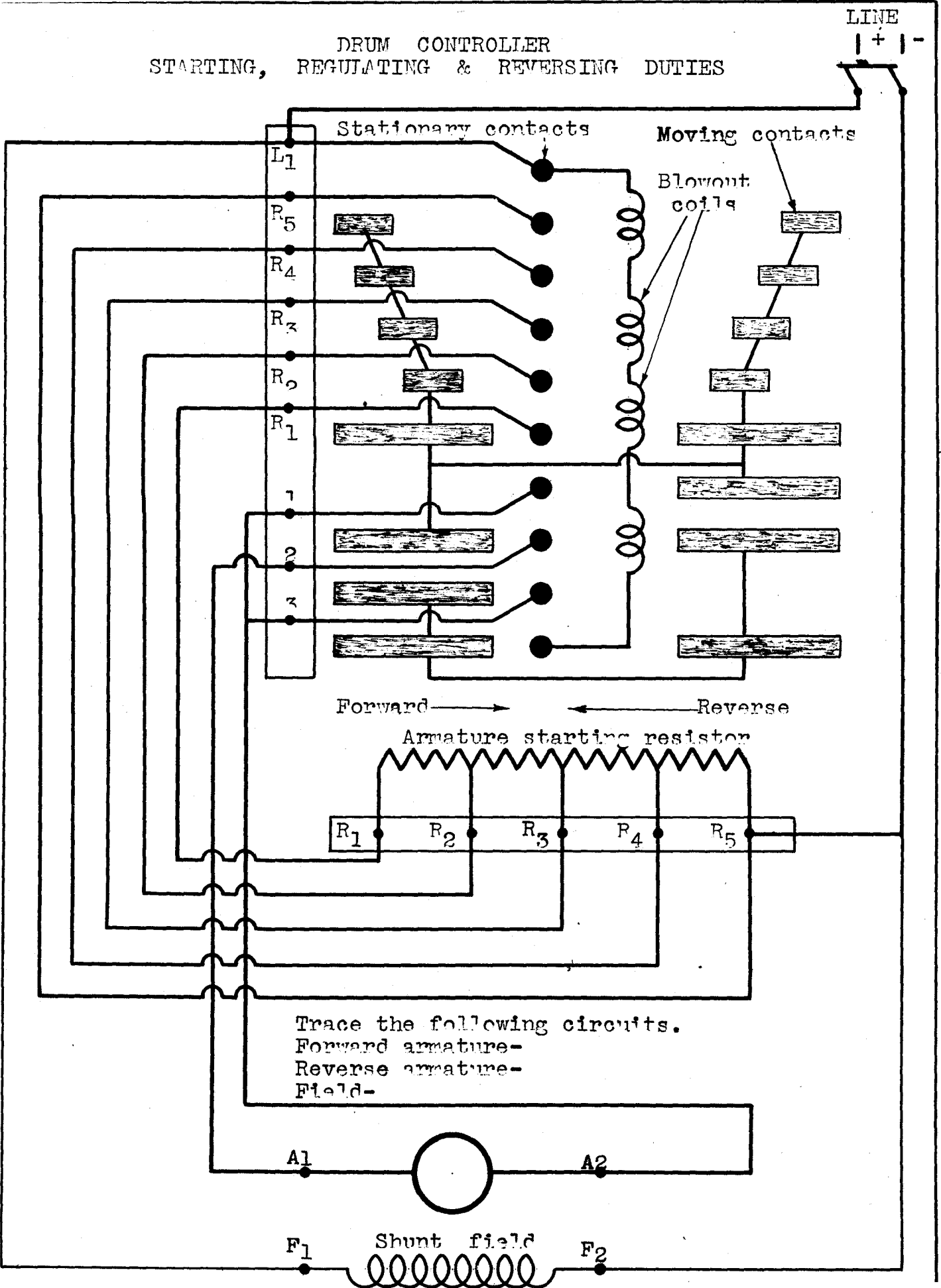

Trace the following circuits.
Forward armature-
Reverse armature-
Field-

DYNAMIC BRAKING

RUNNING

BRAKING

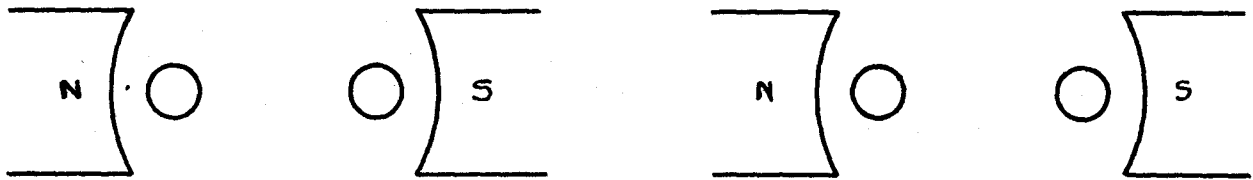

IN FIGURES 1, 2 & 3 SWITCHES A & D ARE CLOSED AND B & C ARE OPEN WHEN RUNNING. SWITCHES B & C ARE CLOSED AND A & D OPEN WHEN BRAKING

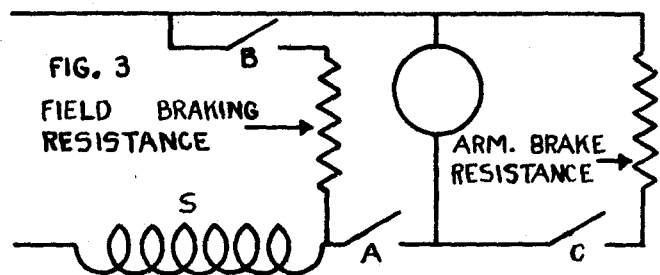
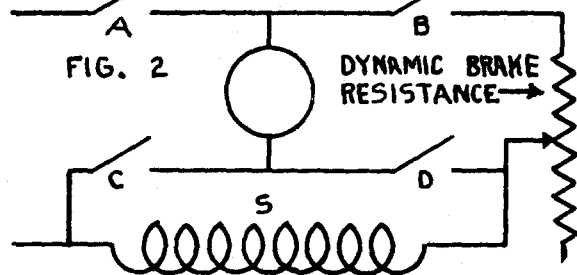
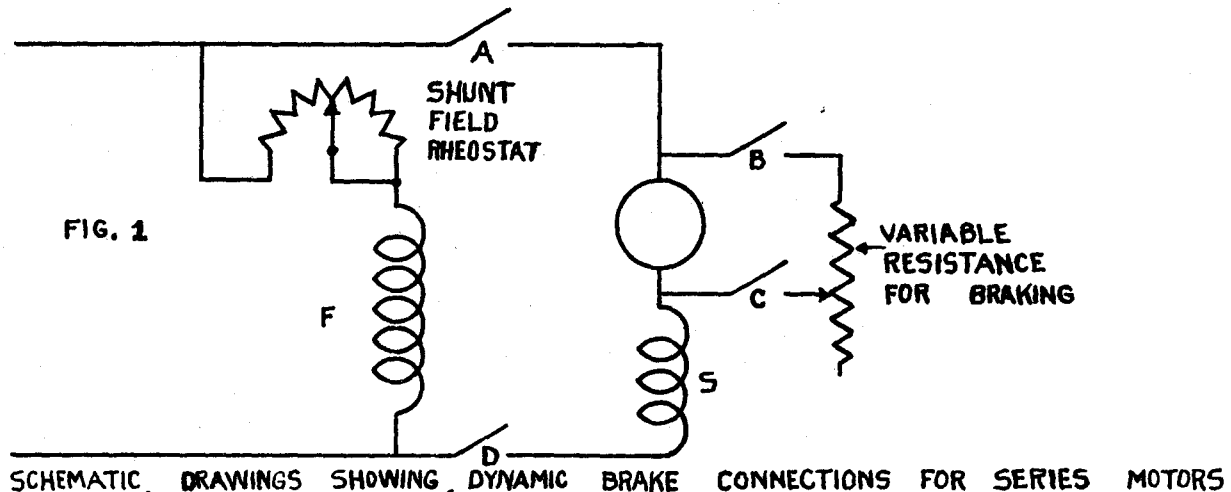

The above diagram in Fig. 1 shows the connection used in dynamic braking, using a compound motor. Fig. 2 shows similar connections for a series motor.

When the source of supply is shut off from a motor, the armature will continue to turn or coast because of its momentum. Any load connected to the motor will also continue to operate. In cases where motors must be stopped quickly, this momentum may be used to generate energy for dynamic braking.

If the shunt field of the motor is excited during the coasting period, the motor will act as a generator and the armature will generate EMF until it stops. By connecting a suitable resistance in the armature circuit, as shown above, the generated armature EMF will cause the armature current and the armature poles to reverse. The reversed armature poles, reacting with the field poles, will now tend to reverse the armature rotation and this action will result in stopping the motor and load.

This form of braking provides a quick, smooth, magnetic form of braking that has many advantages over mechanical methods.

DRUM CONTROLLER USED FOR DYNAMIC BRAKING

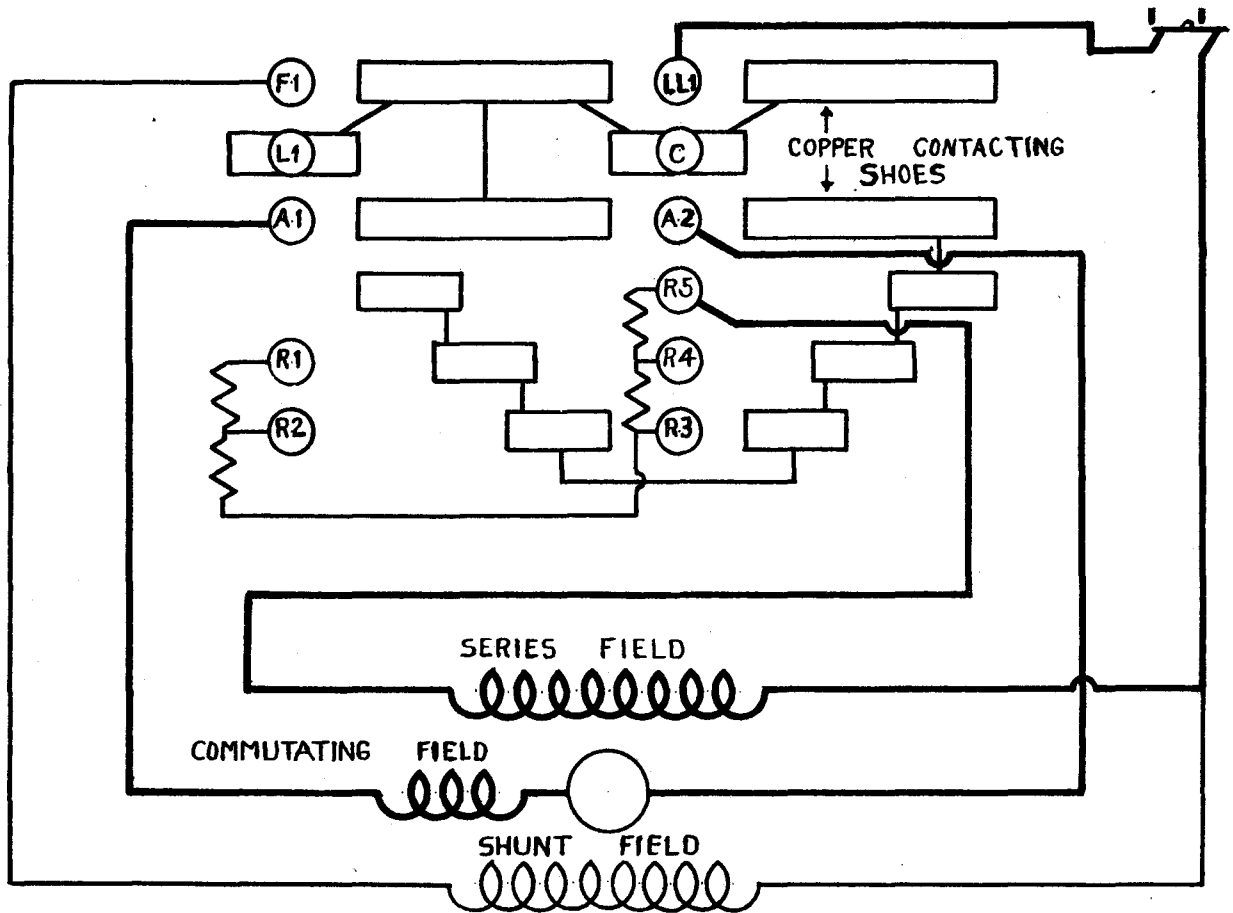

This diagram shows a compound motor controlled by a drum controller having auxiliary contacts for dynamic braking.

Advantages of this type of braking are: no mechanical wear, less maintenance, economical, effective and, although powerful, will not damage the motor is properly applied.

Caution must be used, when applying dynamic braking, to prevent an overload of current through the armature. This is accomplished by connecting a resistance in series with the armature braking circuit, or by decreasing the field strength to lower the CEMF generated.

Dynamic braking is known as "regenerative braking," when the current generated by the CEMF is fed back into the power line. By leaving the armature connected to the line and over-exciting the field, the CEMF becomes greater than the line voltage. This means that the motor will now act as a generator and will help to carry the line load. This method is used on electric trains which run down long grades. In some systems, as much as 35% of the power used is generated in this manner.

Dynamic braking, or regenerative braking, is only effective when the armature is rotating. Therefore, where it is necessary to hold a load which tends to revolve after brought to a stop, some form of magnetic or mechanical brake must be used in conjunction with dynamic braking.

DRUM CONTROLLER
 STARTING, REGULATING, REVERSING AND DYNAMIC BRAKE DUTIES.

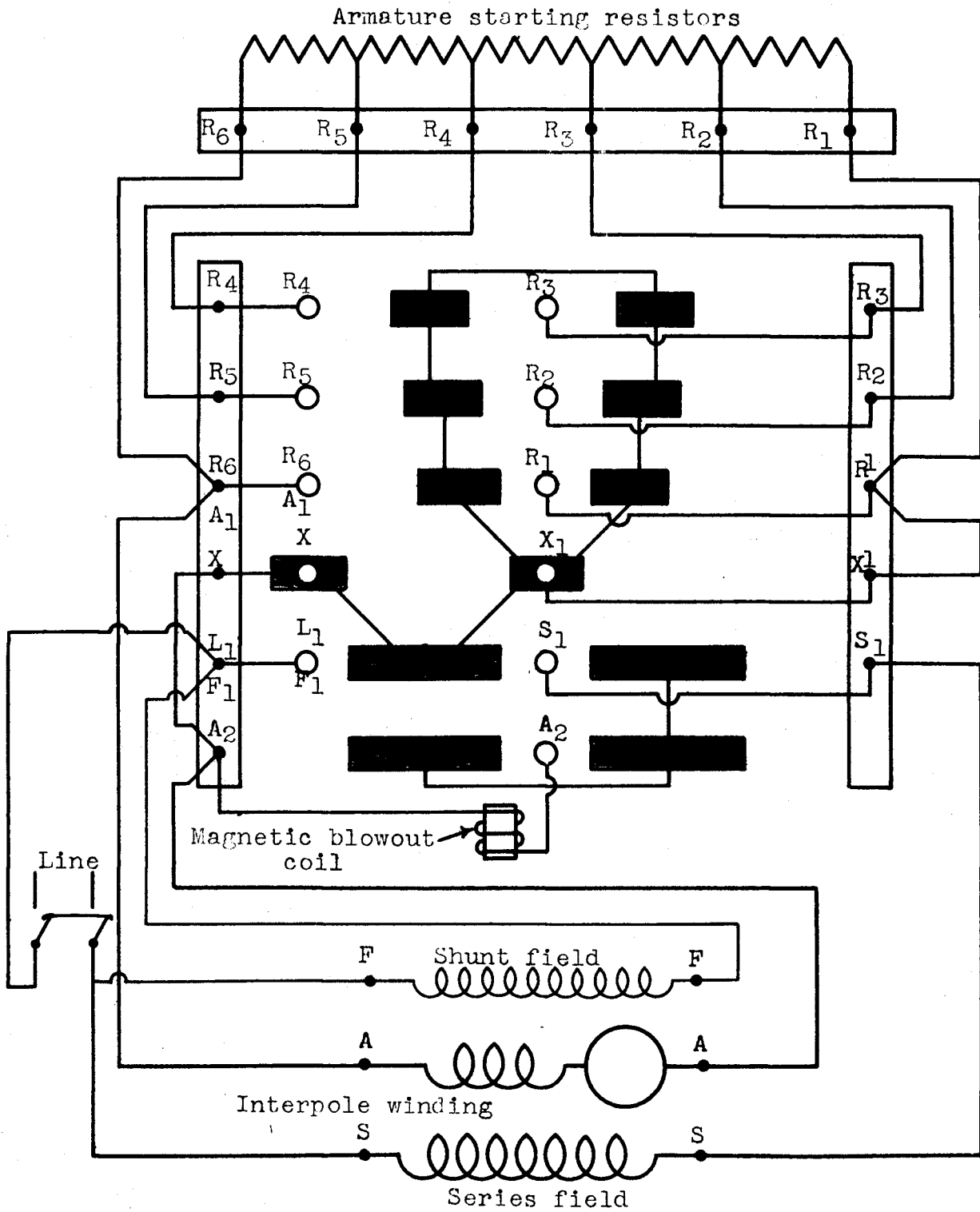

Trace armature, field and dynamic brake circuits.

STARTING, REVERSING AND REGULATING DUTIES

LINE

+ | -

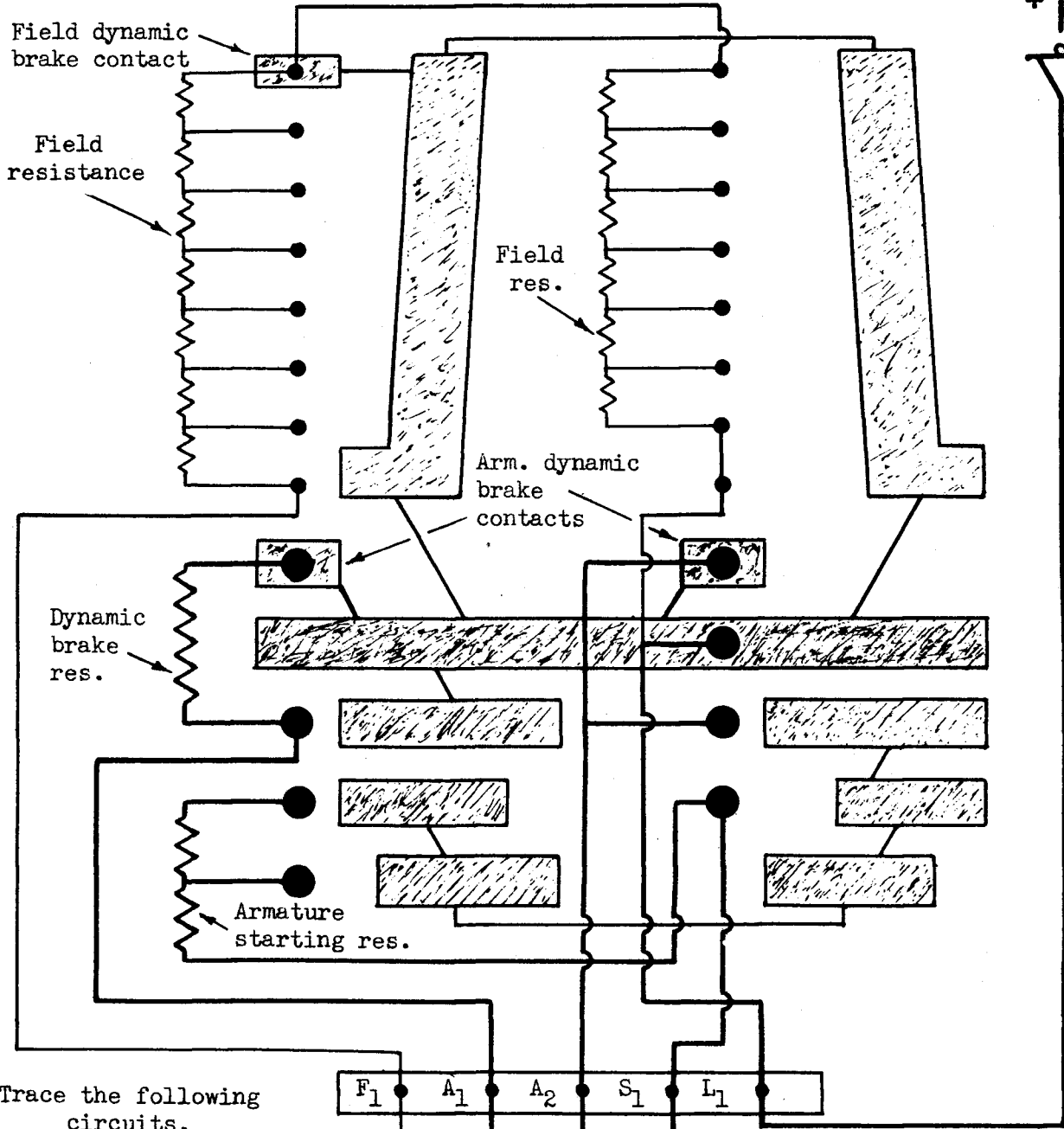

Trace the following circuits.

Armature.

Field.

Dynamic brake.

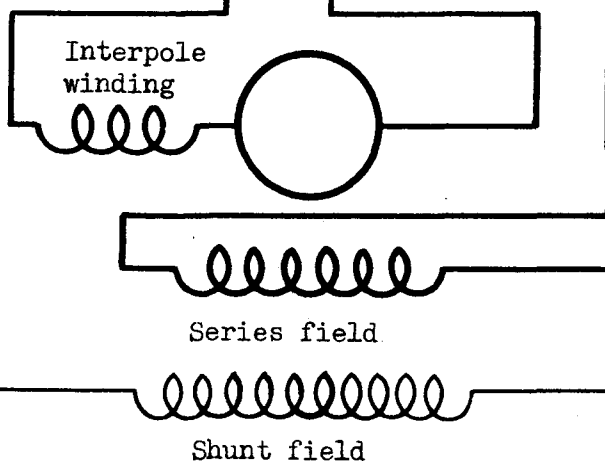

Drum controller for starting, regulating, reversing and dynamic brake duties.

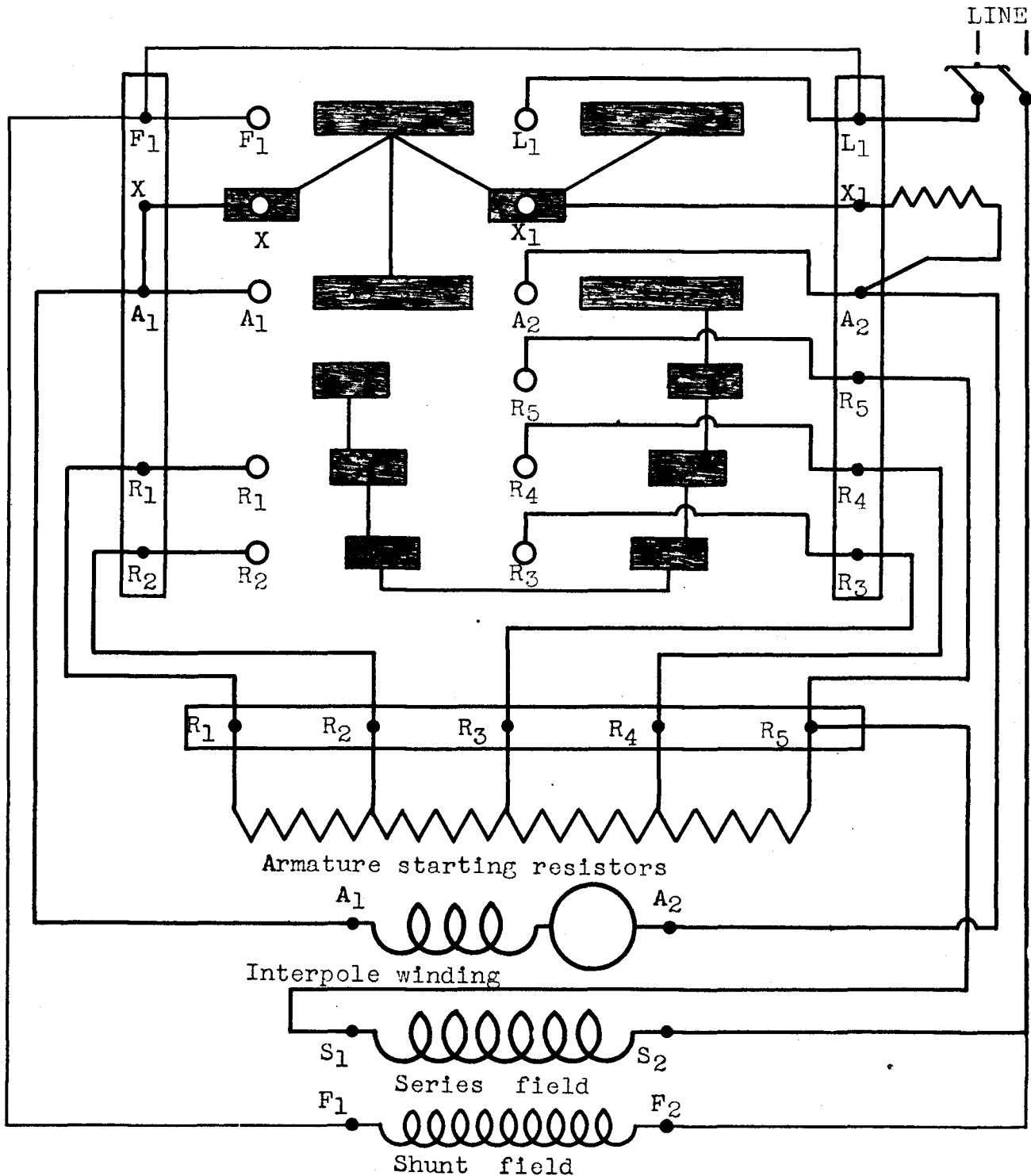

Trace armature, field and dynamic brake circuits. Draw the terminal board on the diagram and test the terminals to identify them. Do not show the terminal board connected. Make all connections as shown for a compound motor. If shunt motor is used connect R5 to L2. If series motor is used omit F1 connection.

SOLENOID STARTER

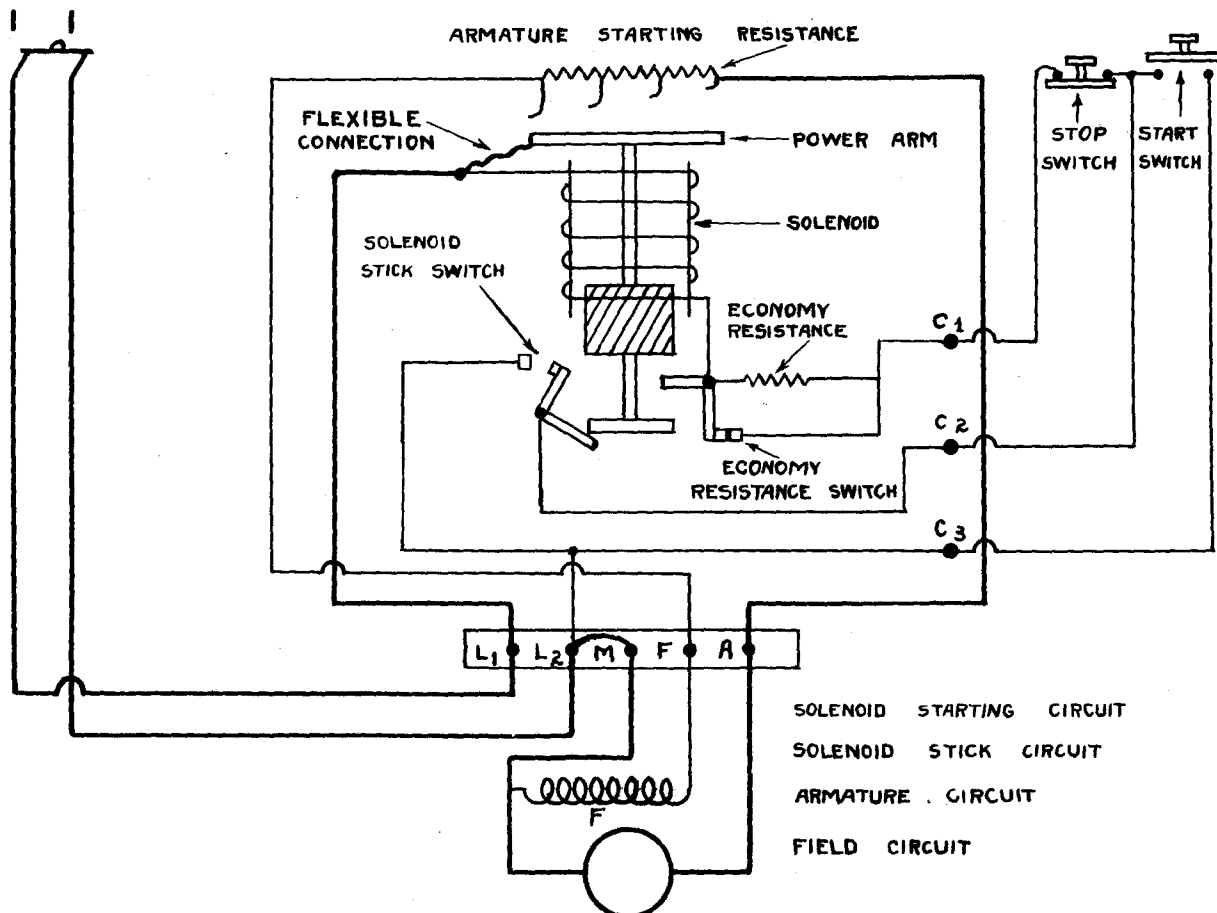

MAGNETIC BLOWOUT COIL

A magnetic blowout coil is for the purpose of providing a strong magnetic field to extinguish the arc drawn when the circuit is broken. It consists of a few turns of heavy wire wound on an iron core which has its poles placed on either side of the contacts where the circuit is broken. This arrangement provides a powerful magnetic field where the circuit is broken.

The arc is a conductor and has a magnetic field set up around it. This field will be reacted upon by the flux of the blowout coil distorting the arc so that it is quickly broken or extinguished. This prevents the arc from burning the contacts.

Magnetic blowout coils are connected in series with the line or in series with the contacts being protected.

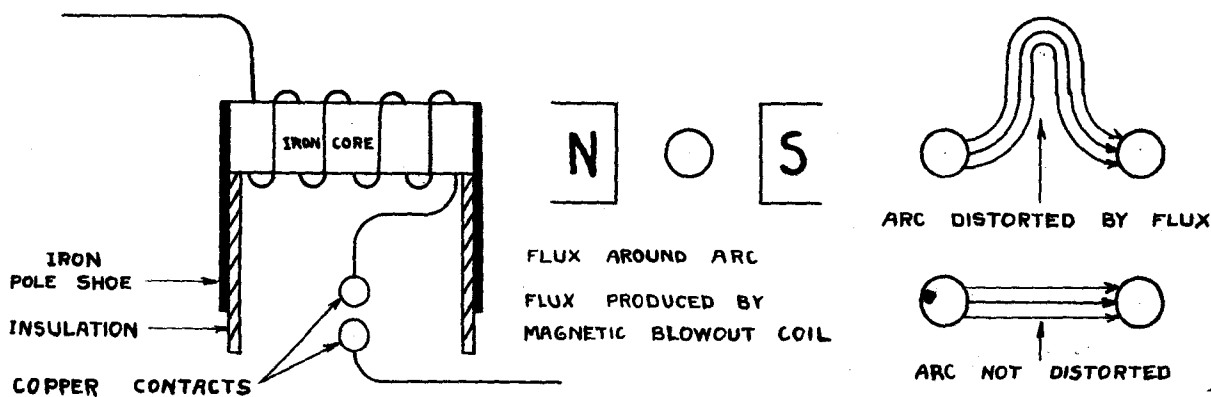

CARBON PILE STARTER

(ALLEN - BRADLEY)

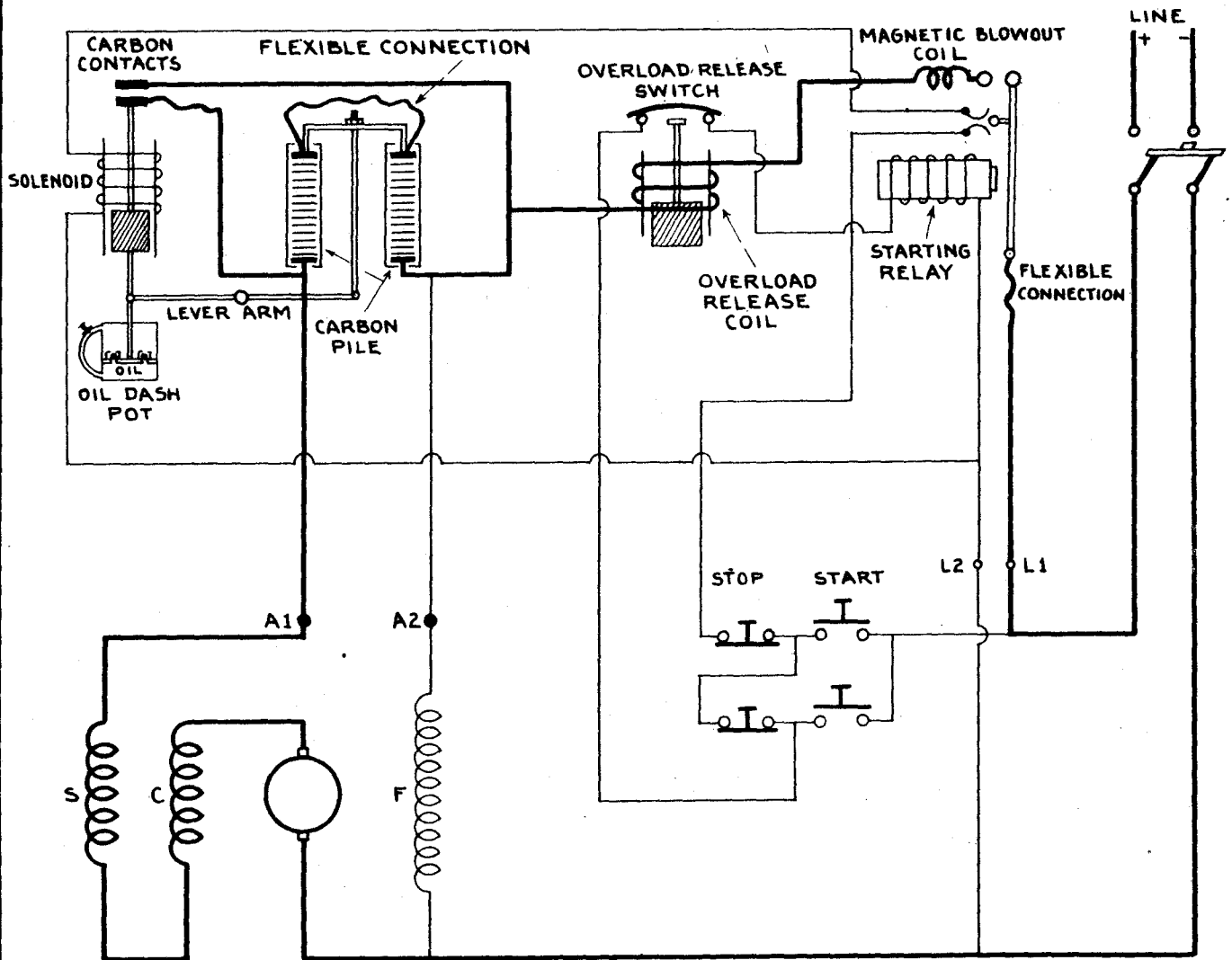

In certain classes of work it is desirable to have very gradual application of the starting torque of the motor when the machine is first put in operation. To accomplish this, it is necessary to start the motor with extremely high resistance in the armature circuit, and limit the starting current to a very low value.

For this purpose, carbon pile starters are made with resistance elements consisting of small carbon disks stacked in tubes of non-combustible material with an insulating lining.

As long as these disks are left loose in the tube, the resistance through them is very high. If pressure is applied to these carbon disks, their combined resistance will be lowered because the greatest resistance is at the contacts between disks. As pressure increases, resistance decreases allowing more current to flow.

This allows the motor to start very slowly, and its speed will gradually increase until normal speed is attained.



WIRING DIAGRAMS

D. C. MAGNETIC RELAYS AND LINE VOLTAGE STARTERS

CLASSES 7001, 7032

Class 7001

Class 7032

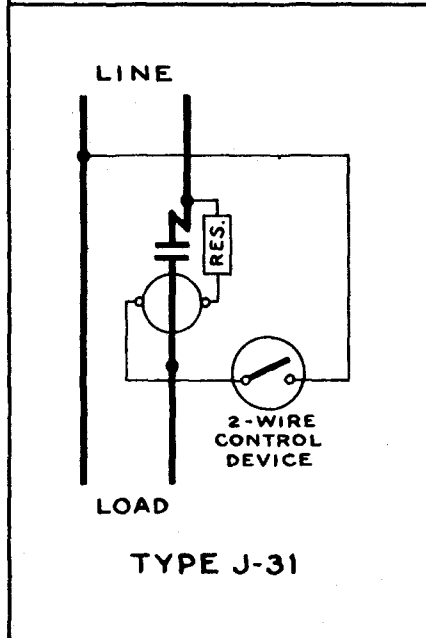
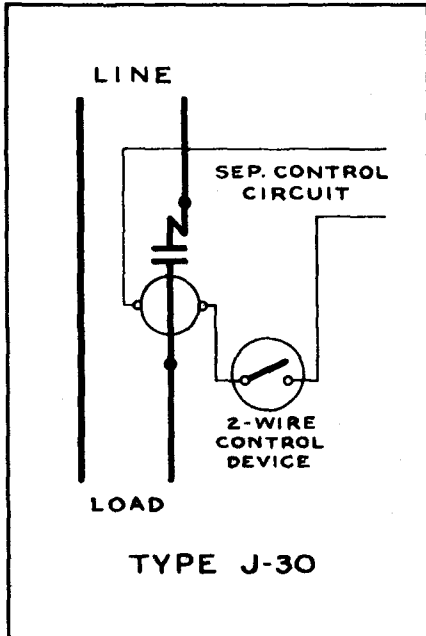

NOTE: CLASS 7001-TYPE K RELAYS ARE WIRED THE SAME AS CLASS 8501 TYPE K. SEE CLASS 8501 WIRING DIAGRAMS.

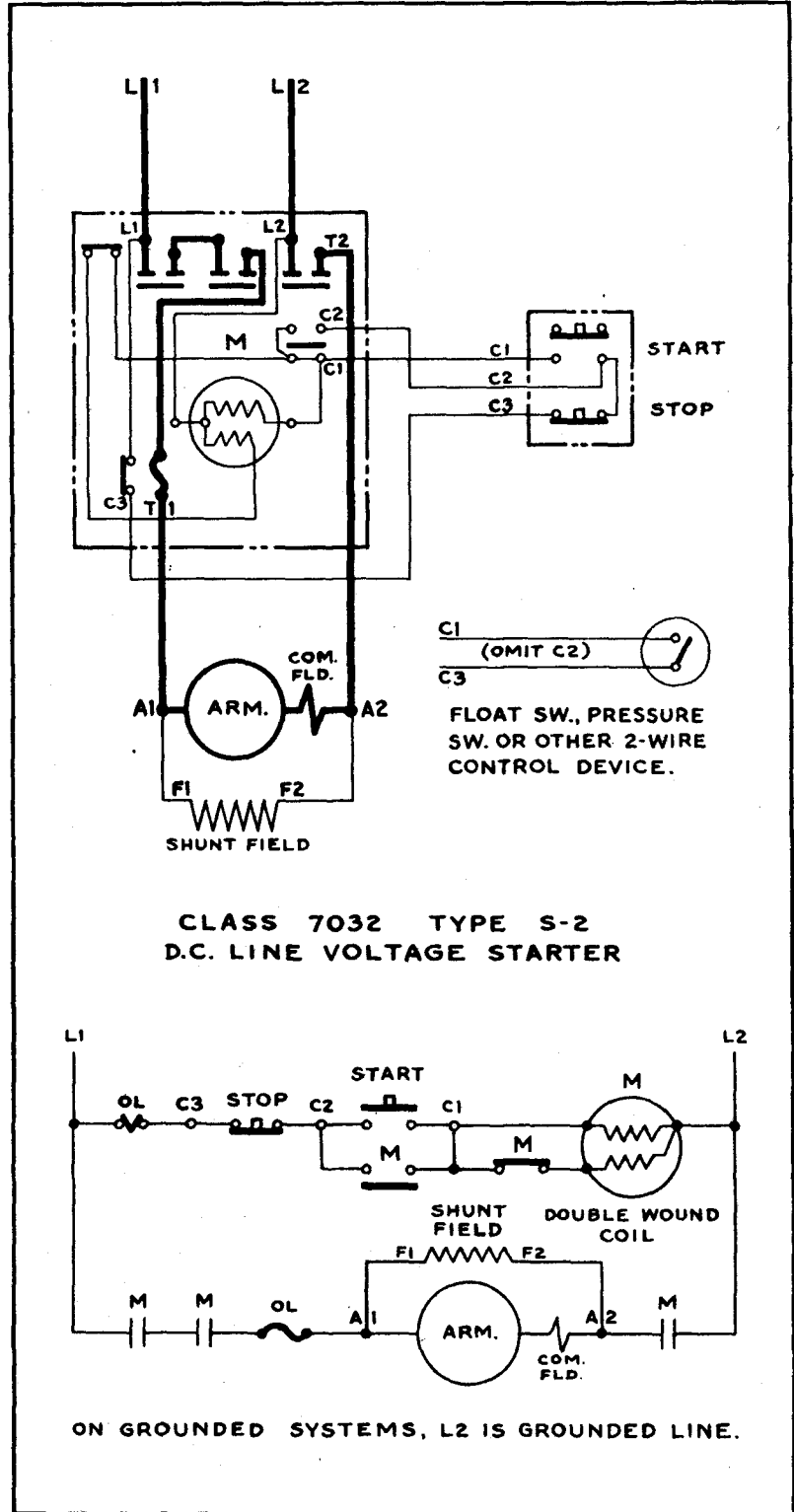

FRONT VIEW DIAGRAM

WHEN AUTOMATIC RESET
O.L. RELAY IS USED
2 WIRE PILOT DEVICE
SHOULD NOT BE USED

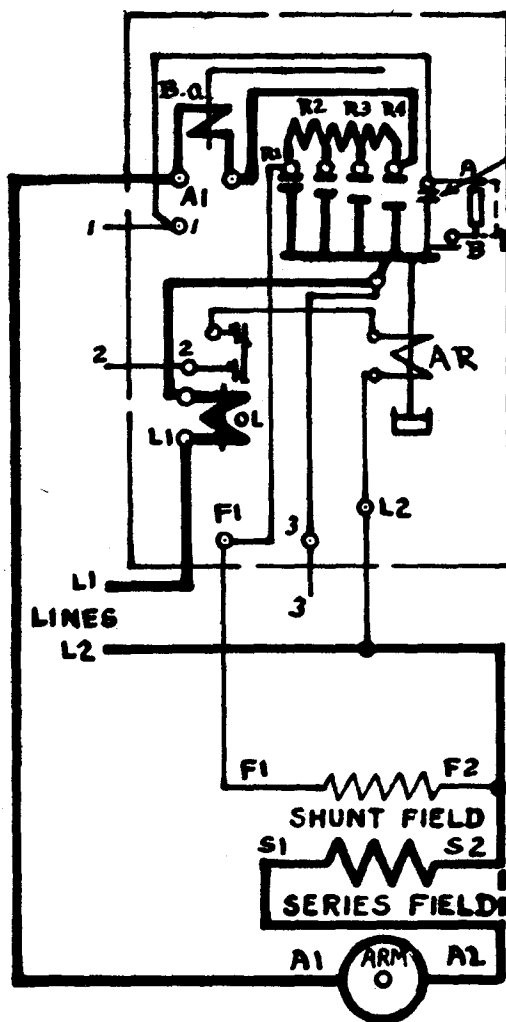

FOR TWO WIRE CONTROL REMOVE PIN FROM LEVER.

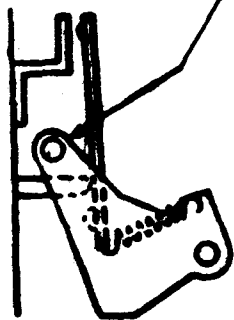

WHEN RESISTOR IS NOT CALLED FOR ON ENG. DATA CONNECT PER DOTTED LINE

2 WIRE PILOT DEVICE

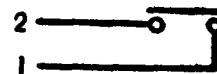

3 WIRE PILOT DEVICE

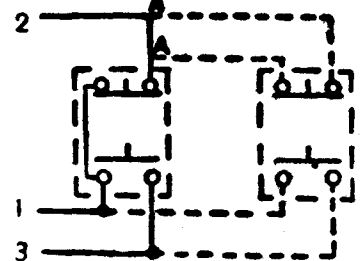

WHEN MORE THAN ONE PUSH BUTTON STATION IS USED CONNECT PER DOTTED LINES OMITTING CONNECTION "AA".

WHEN SERIES FIELD IS NOT USED CONNECT PER DOTTED LINE

LINE DIAGRAM = 87026 D1

TITLE						CONNECTIONS FOR D. C. TIME LIMIT AUTOMATIC STARTER.	
DRAWN BY C. MINOR		TRACED BY N.W. LENTEN		TYPE A	SUP. NO. 50439 D1		
CHECKED BY A.F. WEISS		APPROVED BY C. STANSBURY		BULL. NO. 6106	SUP. BY NO.		
A	G.M.H. R.E.M.	B	G.M.H. L.R.B.	C	R.N.C. R.S.	D	L.R.S. W.C.F.
CUTLER-HAMMER INC. MILWAUKEE						NEW YORK	
						39915 D1	



WIRING DIAGRAMS

D. C. REVERSING LINE VOLTAGE STARTERS

CLASS 7732

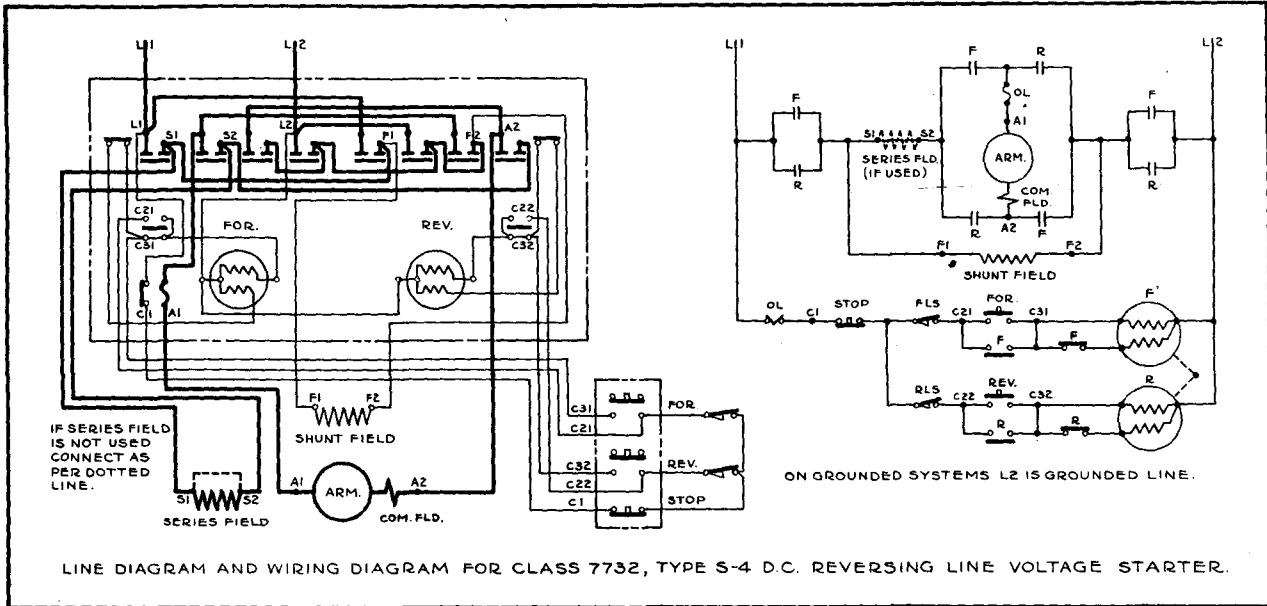

D. C. REVERSING TIME LIMIT ACCELERATION STARTERS

CLASSES 7735, 7736

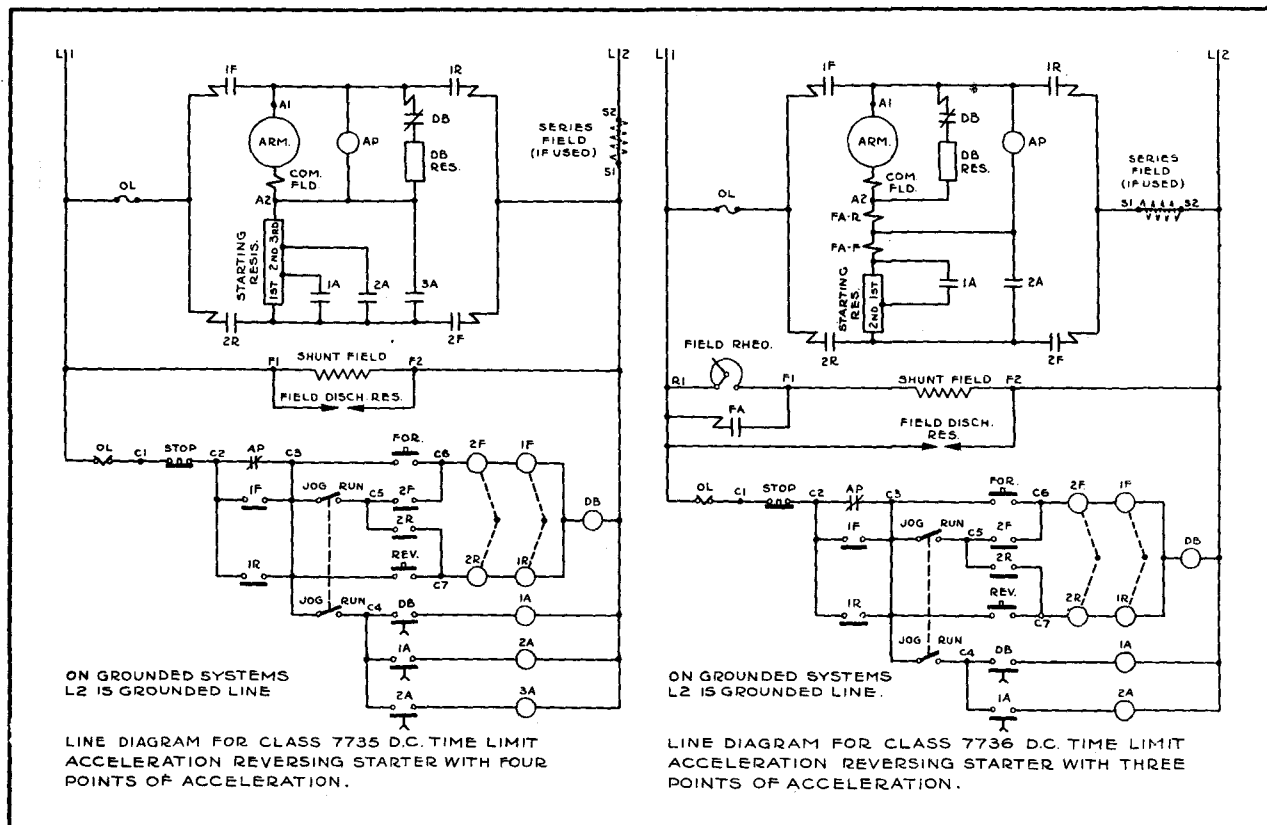

1748-B13

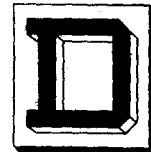

WIRING DIAGRAMS

CLASSES 7107, 7120

D. C. TIME LIMIT ACCELERATION STARTERS

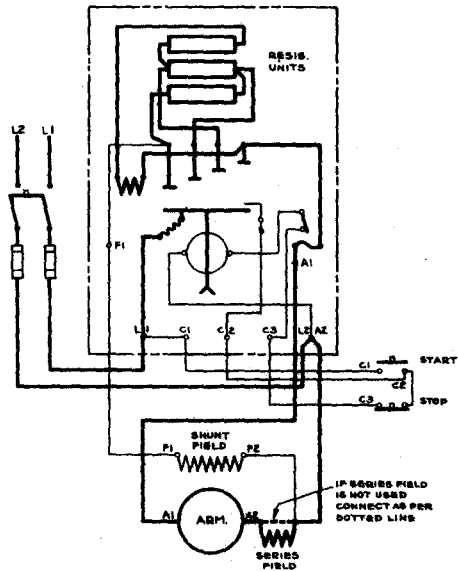

CLASS 7107 D.C. STANDARD DUTY TIME LIMIT ACCELERATION STARTER.

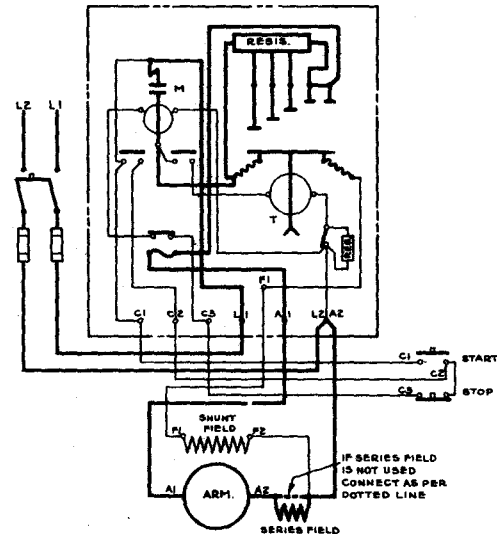

CLASS 7120, TYPE EM-2 D.C. STANDARD DUTY TIME LIMIT ACCELERATION STARTER.

CLASSES 7135, 7136

D. C. TIME ACCELERATION STARTERS

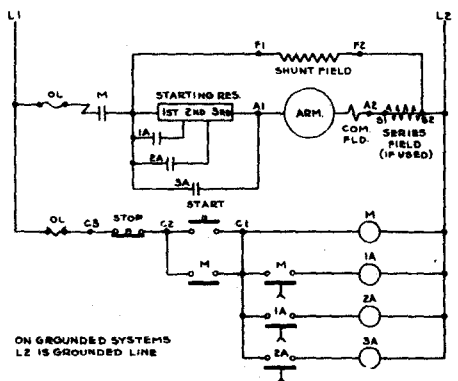

LINE DIAGRAM FOR D.C. CLASS 7135 HEAVY DUTY TIME LIMIT ACCELERATION STARTER WITH FOUR POINTS OF ACCELERATION.

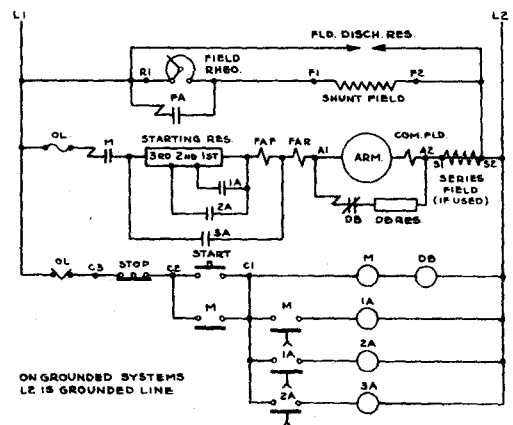

LINE DIAGRAM FOR D.C. CLASS 7136 HEAVY DUTY TIME LIMIT ACCELERATION STARTER WITH DYNAMIC BRAKING.

WHEN RESISTOR IS NOT CALLED FOR ON ENG. DATA CONNECT PER DOTTED LINE

WHEN RESISTOR IS NOT CALLED FOR ON ENG. DATA OMIT DOTTED CONNECTIONS

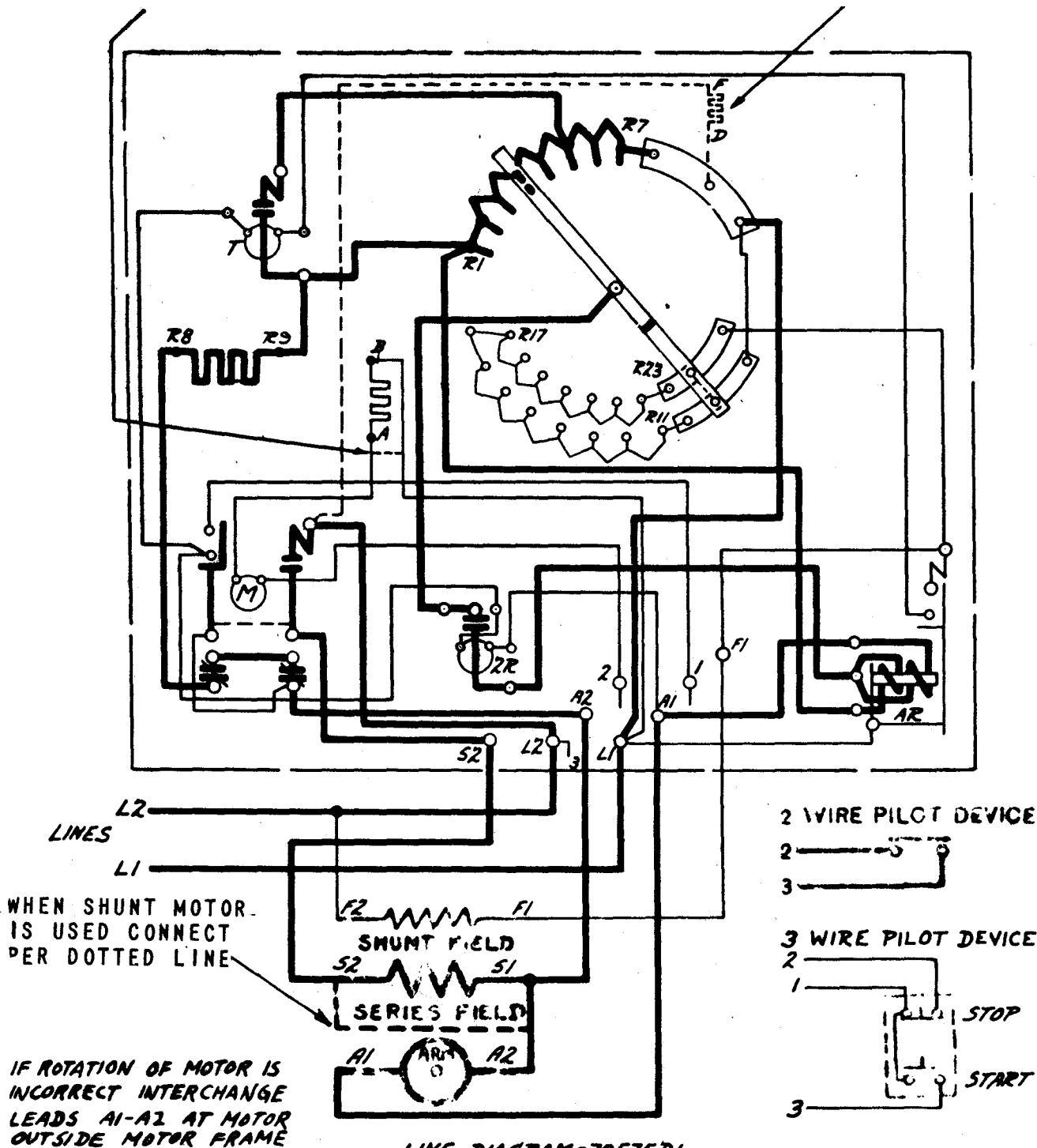

TITLE CONNECTIONS FOR D.C. SPEED REGULATOR.

DRAWN BY <i>McMullen</i>	TRACED BY <i>McMullen</i>	TYPE	SUP. NO.
CHECKED BY <i>Jeldhausen</i>	APPROVED BY <i>[Signature]</i>	BULL. NO.	SUP. BY NO.
A	B	C	D
ORDER NO. A696719			70577DI
CUTLER-HAMMER, INC. MILWAUKEE NEW YORK			

MAGNETIC CONTROLLER

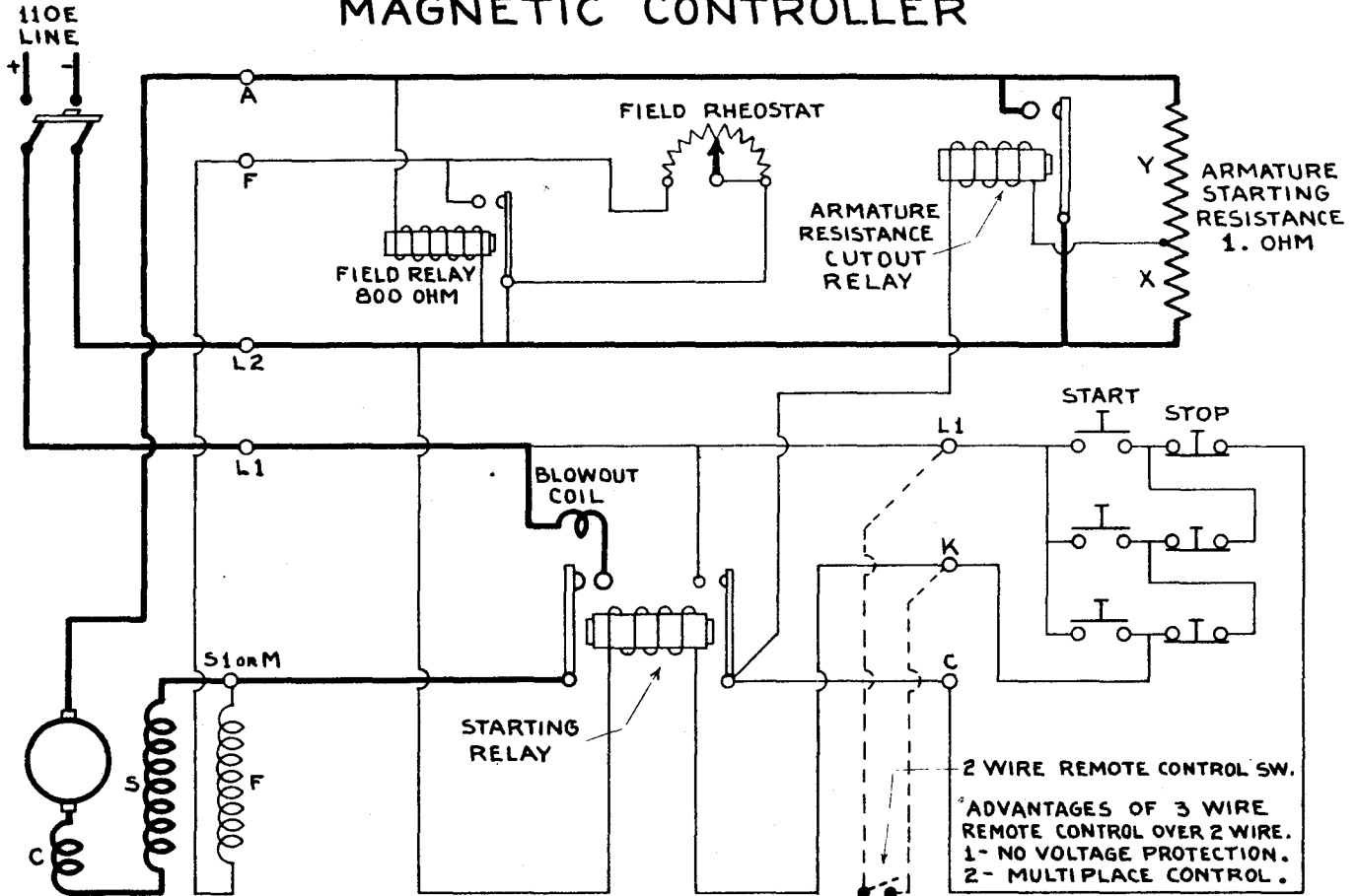

The term "magnetic controller" is commonly used to apply to controllers on which the operation depends almost entirely on relays. Controllers of this type have a number of separate circuits, each operated by a relay switch.

These controllers are used extensively on large industrial motors, steel mill motors, and elevator motors. They can be designed to give any desired operation.

Example: Let us assume we start a 110E, 40I, 5 h.p. motor without a load.

Starting current equals $1\frac{1}{2} \times 40I$ or 60I.

Armature starting resistance equals 1 ohm.

Voltage drop across arm. starting res. equals $60I \times 1R = 60Ed$.

Voltage drop across section of res. marked "X" equals $\frac{1}{3}$ of Ed across entire res. or 20Ed.

Therefore, the voltage applied to the armature resistance cut-out relay when starting, equals $110E - 20Ed$ or 90 volts. This relay is adjusted so that it will not close its switch until it receives approximately full line voltage. The voltage across the relay increases as the current through "Y" + "X" decreases. Current flow will decrease to approximately 6I, because of C.E.M.F. built up in the motor as it increases in speed. This may be proven by the following figures:

Total voltage drop across "Y" + "X" after motor attains normal speed equals $6I \times 1R = 6Ed$.

Now the voltage drop across "X" will be $\frac{1}{3}$ of 6 or 2Ed, leaving 110 minus 2 or 108E to operate the armature res. cut-out relay. This voltage is high enough to operate the relay and close its switch, which cuts out or shunts the armature starting resistance.

The field relay closes when starting to give full strength field. When the armature res. cut-out relay closes, the field relay is shorted out of the circuit. This allows the speed to be controlled above normal by adjusting the shunt field rheostat.

MAGNETIC CONTROLLER

FOR STARTING, REVERSING AND DYNAMIC BRAKE DUTIES

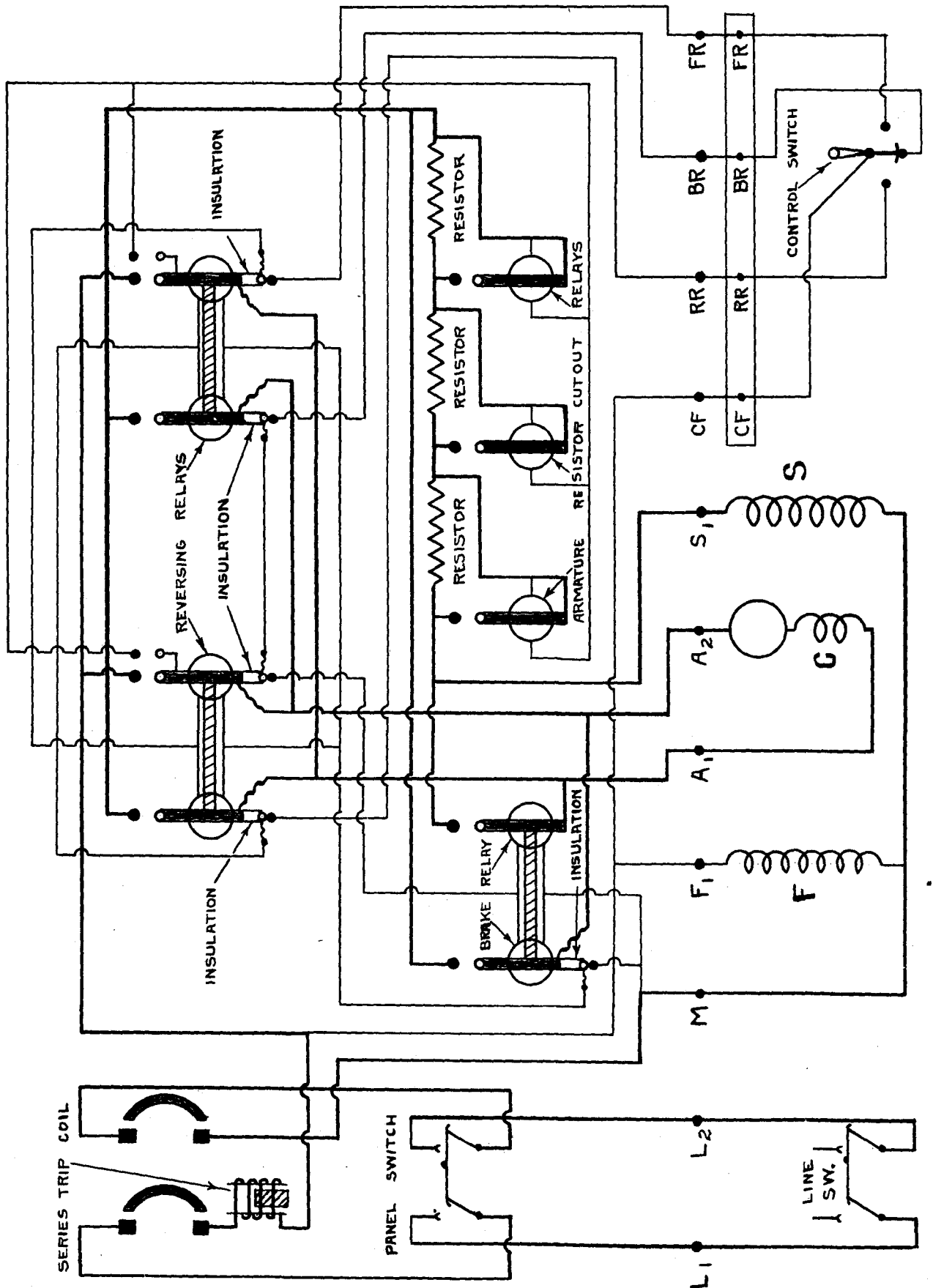

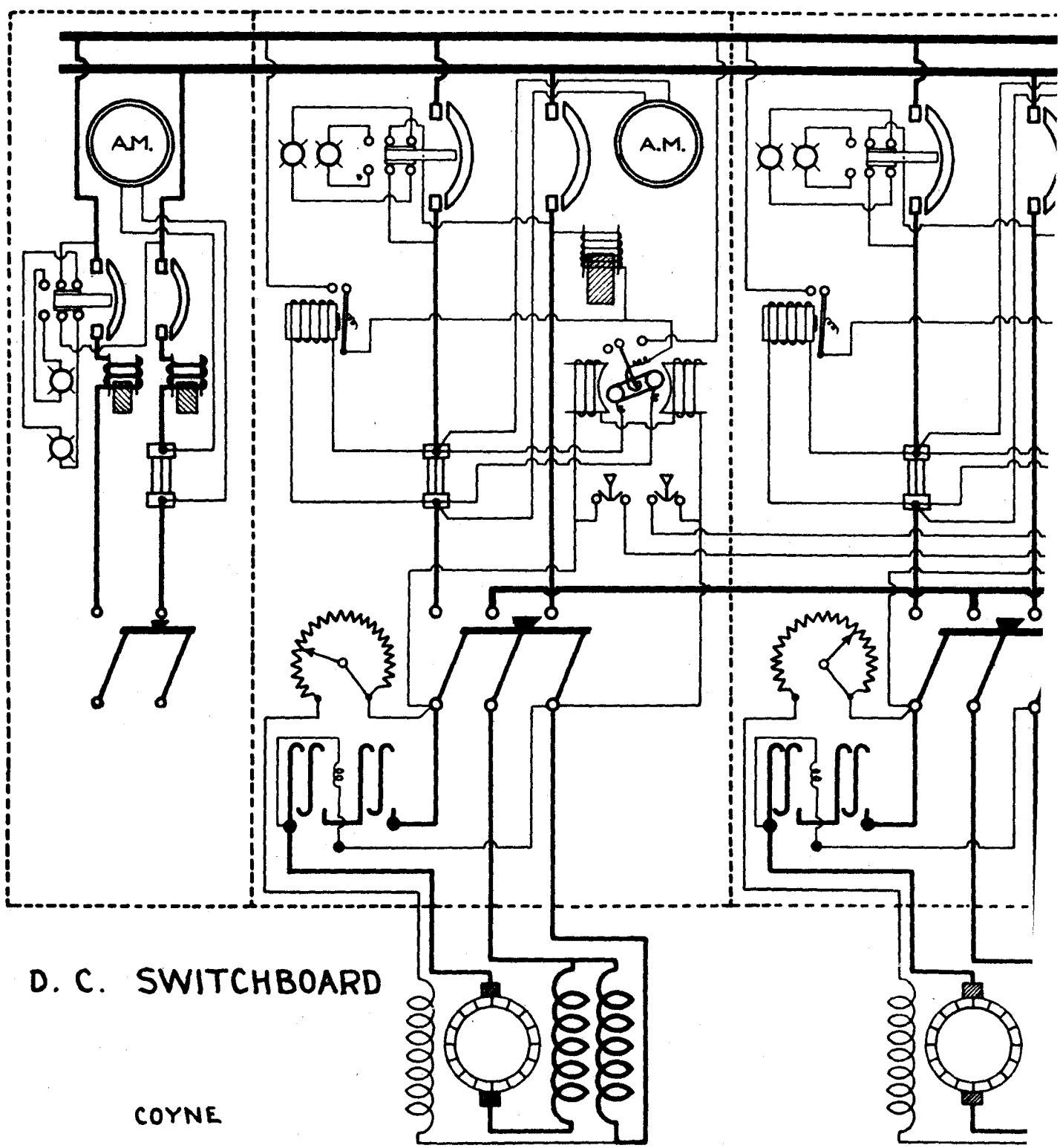

D. C. SWITCHBOARD

COYNE

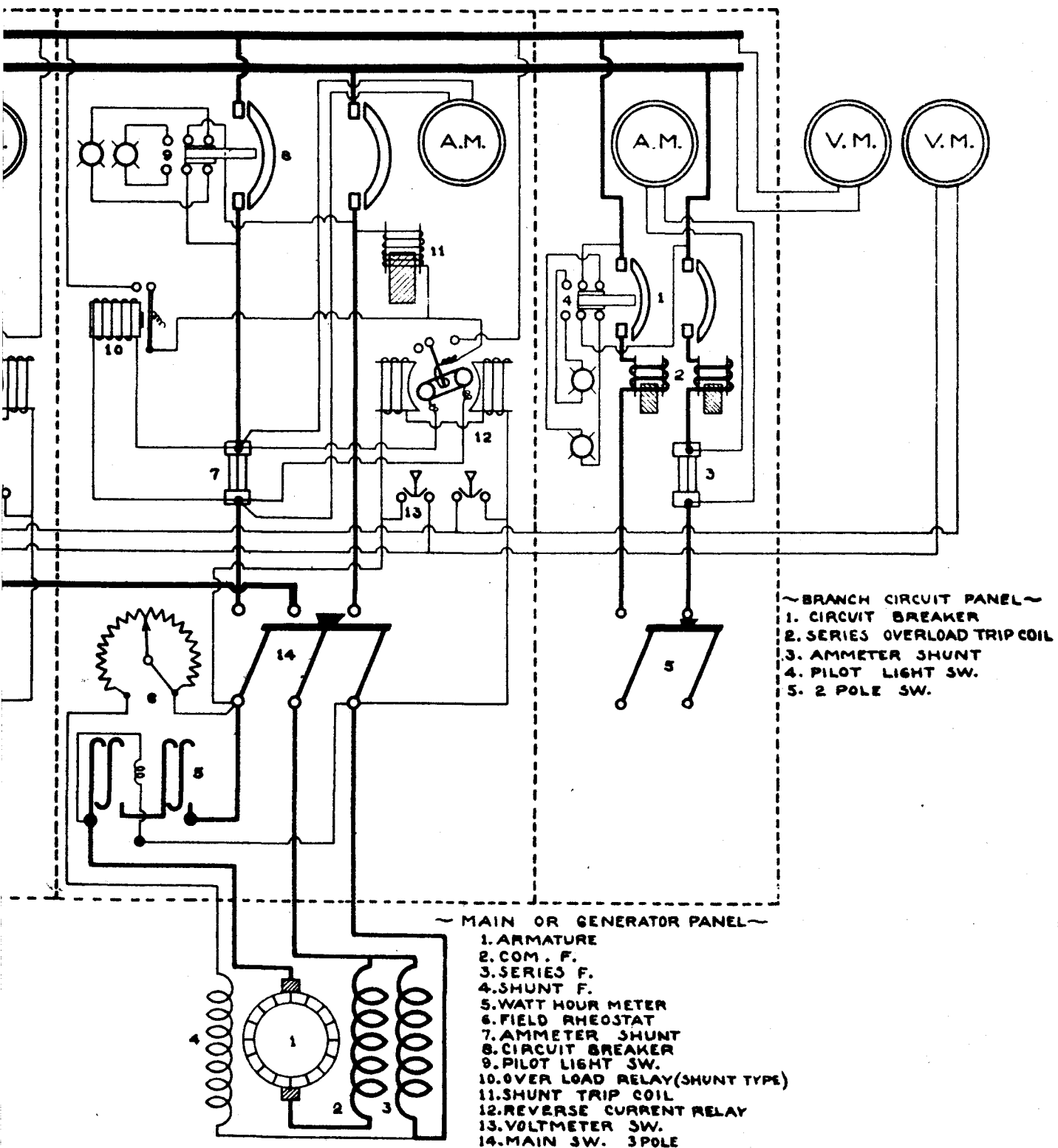

AMPLIDYNE GENERATORS.

If a D.C. generator designed as shown and operated with a very weak field be driven at constant speed, the main brushes may be short circuited as indicated. This action results in relatively heavy currents in the armature that in turn produce an intense armature cross field with the polarities shown and, if the poles are especially designed to provide a magnetic circuit of low reluctance to this cross field, a strong magnetic field will be developed in the air gap. The armature, rotating in this field, produces a relatively high voltage at right angles to the normal brush axis and if extra brushes are placed as shown, power almost equivalent to the normal rating of the machine may be obtained.

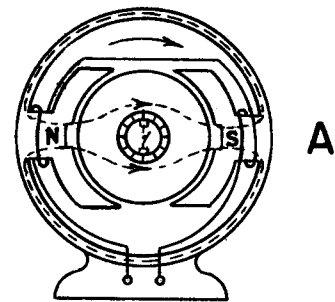

SIGNAL FIELD.

As the operating point for the field magnetism is set on the steep part of the magnetization curve, a small variation in the magnetizing force produced by the field coils will produce a relatively great change in the short circuit current produced by the armature, and this in turn will greatly increase the generated output voltage. Therefore, if special control coils be placed on the poles, and if these coils be fed from a low voltage or low power source, the variations which these coils produce may be caused to reappear in the output circuit in a greatly amplified form. This is the principle of operation of the Amplidyne Generator.

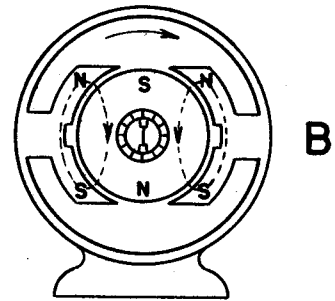

CROSS FIELD.

The Amplidyne Generator may be regarded as a two stage electrical power amplifier, and its use is concerned with control situations in which small controlling impulses are employed to handle equipment that demands a large amount of power to operate it. The small control power is fed to the field coils where it effects a relatively high variation in field magnetism; this variation is amplified in the cross field and again in the output circuit. Amplifications of 20,000 to 1 are common and 100,000 to 1 are possible. Thus a variation of one watt in the input control circuit may produce a change in generator output of 20 kilowatts, a range impractical for any electronic amplifier. The range may be extended by the use of a preamplifier using ordinary radio tubes.

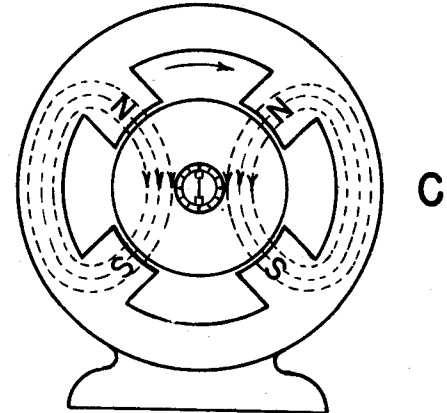

SPLIT POLE DESIGN
SHOWING CROSS FIELD.

Instead of the split-pole construction shown above, the arrangement indicated in fig. C shows the constructional features of a modern amplidyne unit. Although four poles are shown, adjacent groups are wound with the same polarity, and the machine is therefore a two pole unit.

Figure D shows the construction of an Amplidyne unit using interpoles. Although several field windings are employed in an actual machine, only the signal winding is shown. The brushes M are the output brushes from which the amplified energy is obtained.

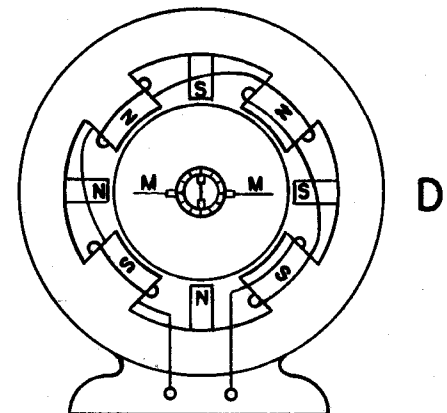

SIGNAL FIELD WINDING.

MULTIPLE-OPERATOR ARC-WELDING SYSTEMS

WELDING-CIRCUIT CONTROL PANELS

These panels are available with either single- or double-unit assembly, providing control, respectively, for either one or two welding circuits. Knife switches provide current adjustments in steps of 10 amp each (5 amp optional). The assembly is enclosed in a substantial sheet-steel case of drip-proof construction, with top-hinged doors and lifting eye as illustrated. With double-unit assembly, an extra knife switch provides for paralleling the two circuits so that one operator can be served with twice the welding current available from either single circuit.

The standard control panels are designed to provide a voltage drop of 35 volts. Panels providing a voltage drop of 30 volts are also available.

Control panels which provide greater voltage drop (as required with lightly coated electrodes), or which provide less voltage drop (as required with carbon electrodes), are also available.

Reactors are available for use in conjunction with these control panels as an optional feature. Their use is a matter of preference of the purchaser. Most constant-potential welding-circuit installations being made today do not employ reactors and obtain completely successful operation with

heavily coated electrodes. On circuits for bare and lightly coated electrodes, reactors are usually recommended.

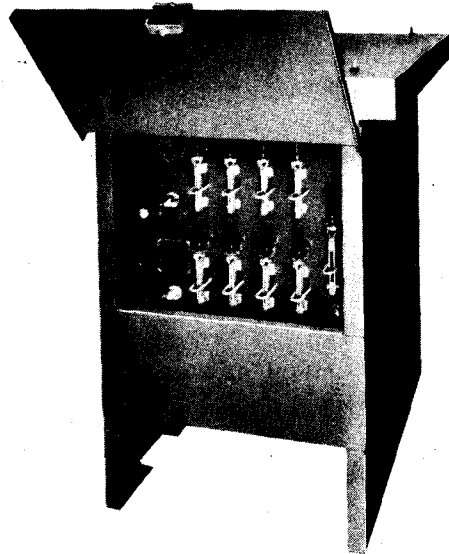

Typical welding circuit control panel with double-unit assembly

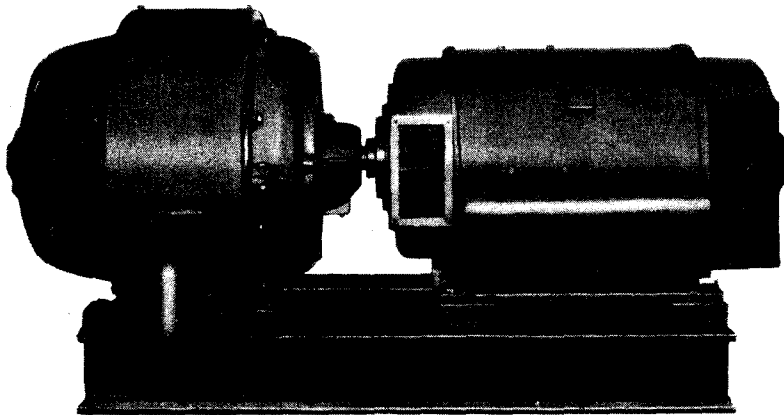

Typical appearance of the new G-E multiple-operator arc-welding set with drip-proof covers

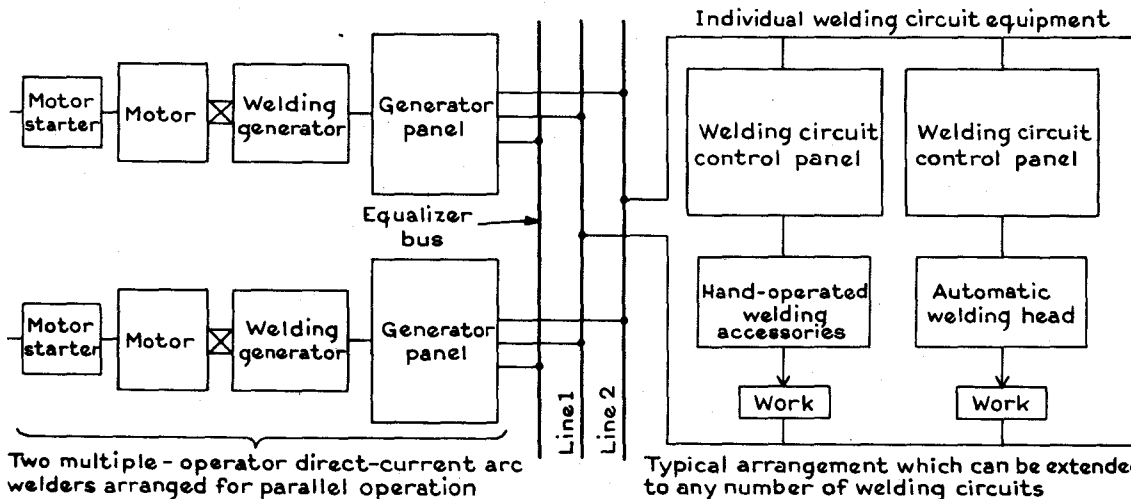

Two multiple-operator direct-current arc welders arranged for parallel operation

Typical arrangement which can be extended to any number of welding circuits

The flexibility of capacity obtained by parallel operation of multiple-operator, constant-potential arc welders is well illustrated by the above diagram. Total capacity may be increased at will by adding

ing additional sets and any number of individual welding circuits may be used up to the total installed capacity.

ALTERNATING CURRENT APPARATUS

This section contains wiring diagrams and brief explanations of the action of devices and equipment that operates with alternating current. The pages are arranged in the following order of subjects:

Alternating-current circuits and basic principles.
Transformers and wiring.

Motors: Three-phase and two-phase; squirrel cage, slip ring, and synchronous. Single-phase; split phase, capacitor types, repulsion start, repulsion-induction and shaded pole.

Starters: Across-the-line types, resistance types, auto-transformer or compensator types.

Controllers, speed and reversing.

The following notes apply to diagrams and other material on pages where complete explanations are not given on the page itself.

PAGE 160

Alternating current flows first one direction and then the opposite direction in its circuit. The flow in each direction is called an alternation. Two alternations, one in each of the two directions, make one cycle. As shown by the upper diagram, the voltage during one complete cycle, also the current during one cycle, rises from zero to maximum in one direction, falls back to zero, rises to maximum in the opposite direction, and returns once more to zero at the end of the cycle.

The middle diagram and the table below it show how the number of cycles per revolution of an alternating-current generator depends on the number of magnetic poles in the generator. The number of cycles per second is called the frequency of the alternating current.

The lower diagram shows that a three-phase generator produces three simultaneous voltages and currents with evenly spaced peaks and zero points of voltages and currents in the three "phases."

PAGE 161

An ideal alternating voltage or current rises and falls at a rate that follows a curve of sines, hence is called a sine wave voltage or current. On a sine

curve the value of voltage or current at any instant is proportional to the sine of the angle through which a conductor in the alternating-current generator has progressed from the point of zero voltage or current. Sines and other trigonometric functions are used in making certain alternating-current calculations; chiefly in engineering and design work.

PAGES 169-170

The three generator panels, numbers 1, 2 and 3, are similar. To the bottom of each panel is connected an alternator or alternating-current generator. Three leads come from the three output terminals of the generator, from which is supplied three-phase current. Two wires carry direct-current to the generator field windings. Two more wires, at the lower right-hand corner of the panel, come from the exciter. The exciter is a direct-current generator that furnishes direct-current for the alternator field winding.

The three output leads from the generator enter the switchboard panel, pass through instrument transformers (marked H1 and X1), then through a manually operated knife switch, through a magnetic overload circuit breaker, and thence to the three bus bars at the top of the panel. The buses connect to the other generator outputs and to the feeder panels.

At the top of each generator panel is an ammeter, a voltmeter, and a kilowatt meter. At the bottom of the panel is a kilowatt-hour meter. Currents for these meters come from the current transformers (instrument transformers) shown on the generator output leads. Voltage for the instruments comes from the potential transformers (instrument transformers) which are toward the right from the circuit breaker.

Near the center of generator panel No. 1 is a knob for regulating the speed of the prime mover, such as an engine, that drives the alternator. There is also a field rheostat for controlling the alternator field current, and a field discharge switch used when the machine is shut down. On panel No. 2 there are overload relays, and on panel No. 3 there is a power factor meter.

On each feeder panel is an ammeter connected through a current transformer, also an automatic overload circuit breaker and a manually operated knife switch. The feeder panels connect between the generator buses at the top of the switchboard and the leads to the several load lines.

PAGE 175

Power factor (abbreviated P.F.) is the ratio of the alternating current that is useful in producing power, to the total current flowing in the circuit. For example, if the total current is 100 amperes, but if only 70 amperes of current is useful in producing power, the power factor is $70/100$ or is 70% or is 0.7.

Apparent power is measured in volt-amperes (V.A.) and is equal to the voltage multiplied by the amperes of total current in the alternating-current circuit. True power is measured in watts, as indicated by a wattmeter. The power factor of an alternating-current circuit is equal to the number of watts of true power divided by the number of volt-amperes of apparent power.

The power factor can be 1.0 or 100% only in a circuit containing only resistance without either inductive reactance or capacitive reactance, or in a circuit where the ohms of inductive reactance are exactly equaled by the ohms of capacitive reactance. In any circuit containing unbalanced inductive reactance or unbalanced capacitive reactance the power factor will be less than 1.0 or less than 100%.

PAGE 182

The main distribution panel receives three-phase current through a four-wire circuit. Such a four-wire three-phase line comes from the secondary winding of a transformer having connections as shown by the small diagrams toward the right from the main distribution panel. Note that one of the four wires is grounded at the transformer and also from the main distribution panel. Such a distribution system allows running two-wire single-phase branch circuits for lighting, also three-phase three-wire lines for power.

The automatic compensator shown in the lower right-hand corner is a type of motor starter. Several diagrams for such starters are shown on following pages in the division devoted to starters and controllers.

PAGE 185

The squirrel cage motor is a three-phase alternating-current induction motor. In the stationary

frame of the motor are stator windings connected to the three-phase supply line. Revolving inside the stator is the rotor, on the outside of which are parallel conductors running parallel to the central shaft. All these conductors are joined together at their ends by rings. Three-phase current in the stator windings produces a magnetic field which rotates as shown by the upper diagrams. Currents and magnetic fields induced in the rotor cause the rotor to revolve with the rotating field of the stator.

PAGES 191 TO 195

These pages show three-phase and two-phase stator windings as used in squirrel cage induction motor.

PAGES 196 AND 197

These pages show windings which produce consequent poles. A consequent pole is a magnetic pole on which there are no windings, but through which a magnetic flux is produced because it is part of a magnetic circuit in some other part of which there is a winding. Poles on which there are windings are called wound poles, thus distinguishing them from consequent poles.

PAGES 200 TO 202

These pages show connections for motors that may be connected to operate on either of two line voltages, such as on 110-120 volts or on 220-240 volts.

PAGE 213

Single-phase alternating-current motors differ from three-phase and two-phase types in that the single-phase motor requires some constructional feature that enables it to be self-starting. Polyphase (3-phase and 2-phase) motors are self-starting because the polyphase currents produce a rotating field and the rotating field causes the rotor to revolve. A single-phase current, by itself, does not produce a rotating field but produces a stationary field, and there is nothing to start the rotor from standstill.

This page shows the principles of the three basic types of single-phase motors. These types are explained on following pages.

PAGE 216

These single-phase split-phase motors have a centrifugal starting switch between one side of the line and the "start" winding, and in the other line have an automatic overload relay. One of the mo-

tors is a two-speed type having two main windings or running windings.

PAGE 222

These capacitor motors are of the non-reversing type, in which there is no provision for changing the connections to run the motor either clockwise or counterclockwise.

PAGES 223 AND 224

These capacitor start motors may be operated either clockwise or counter-clockwise by interchanging the leads as directed on the diagrams.

PAGES 226 TO 230

These diagrams show two-speed types of capacitor motors.

PAGES 232 AND 233

All of these motors of the reversing type with which a switch is operated to run the motor either clockwise or counterclockwise.

PAGE 246

By following the diagrams from top to bottom in the left-hand column, then in the right-hand column, you will follow the development of an automatic or magnetically operated motor starter of the cross-the-line type. An across-the-line starter or a line starter is one in which the full voltage of the supply line is applied to the motor as soon as the starter operates. With resistance starters and with compensators the applied voltage is reduced while the motor starts from a standstill and comes up nearly to normal running speed.

PAGE 247

The start switch is the left-hand member of the two-button unit with terminals numbered 1, 2 and 3. With the start switch closed, current from L1 goes through the overload trip contacts, the holding magnet winding, the second pair of overload trip contacts, from 3 to 2 through the closed stop switch, from 2 to 1 through the closed start switch, and to L3. The main contacts are drawn closed, thus closing the holding contacts so that the magnet circuit remains closed after the start switch is released and opens.

PAGE 249

With the start button contacts closed, current from L3 flows through switch contacts 3, 1 and 2, through running magnet 4, overload trip contacts 5, and L2. The running magnet closes the main

contacts and the stick contacts. The stick contacts maintain a path from L3 to push button terminal 1 when the start contacts are allowed to open.

PAGE 250

With the start switch closed, current flows from L1 through the start switch, the right-hand overload trip switch, the winding of the magnet shown in the center, the left-hand overload trip switch, and to L3. The holding contacts are at the right-hand end of the long contact bar. With the holding contacts closed, they maintain a path from L1 around the start switch and to the right-hand overload trip switch.

PAGE 255

The resistors inserted in the motor leads during starting consist of many carbon blocks carried inside of insulating tubes or supports. With no pressure applied, the resistance through the series of blocks is high. The more tightly the blocks are pressed together (by the carbon pile depresser handle) the lower the resistance becomes. Starting current flows from L1, L2 and L3 through the three carbon pile resistors to the three terminals of the motor. After the motor comes up to speed the running contactors close, thus allowing current from L1, L2 and L3 to pass to the motor terminals without going through the carbon piles.

PAGE 257

In this resistance starter closing the three sets of contacts just below terminals L1, L2 and L3 allows line current to flow through these contacts and to the motor terminals through fixed resistors R1-R2, R11-R12, R21-R22. After the motor has gained speed the fixed resistors are short circuited by the pairs of contacts that are parallel with the resistors, thus allowing line current to flow through the starter without any resistors in circuit. Overload releases are shown near terminals T1 and T2 in the starter. The magnet that operates the upper contacts is marked M, and the one for the lower contacts is marked 2R. The 2-wire pilot device is a start and stop switch for connection to starter terminals 2 and 3. The 3-wire pilot device, with separate start and stop buttons, connect to starter terminals 1, 2 and 3.

PAGE 258

These are resistance starters using fixed resistors in series with the motor leads for starting, with the resistors short-circuited by parallel contacts after the motor gains speed.

Alternating Current Apparatus

PAGE 259

At the top of the page are resistance starters with which the starting resistances are inserted into the rotor windings instead of in series between the line and the stator terminals of the motor.

PAGES 261 TO 264

These diagrams show connections for auto-transformer starters that are operated manually, by hand with a lever. Auto-transformer starters are called also compensators.

PAGES 265 TO 270

The compensators or auto-transformer starters shown on these pages are of the automatic type operated by means of electromagnets and start-

stop switches instead of manually with a hand lever. The operating principle is the same as that of manual compensators so far as motor voltages and currents are concerned.

PAGES 276 TO 281

These diagrams show various types of manually operated and magnetically operated starters or controllers. A controller, as distinguished from a starter, usually is considered to be a device which not only starts and stops a motor but also varies the speed or the direction of rotation of the motor.

PAGES 282 TO 284

Drum controllers frequently are used with slip-ring or wound-rotor motors for control of speed, power and direction of rotation.

FUNDAMENTAL PRINCIPLE OF A.C.

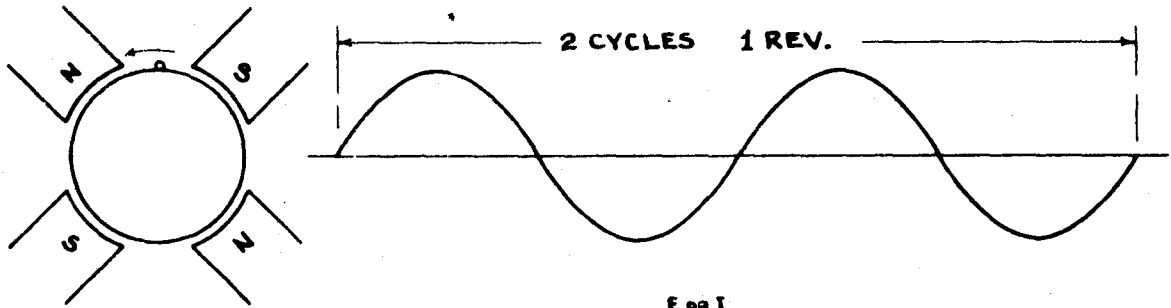
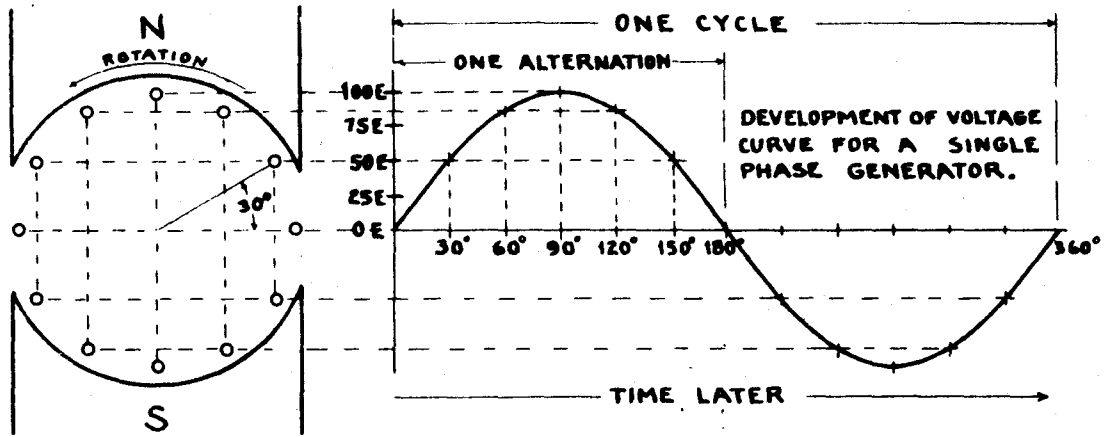

NO. OF POLES	CYCLES PER REV.	REV. PER SEC. FOR 60~	R.P.M. FOR 60~	INDUCTION MOTORS	
				R.P.M. OF MAGNETIC FIELD	R.P.M. OF ROTOR
2	1	60	3600	3600	3450
4	2	30	1800	1800	1740
6	3	20	1200	1200	1160
8	4	15	900	900	860
10	5	12	720	720	690
12	6	10	600	600	580

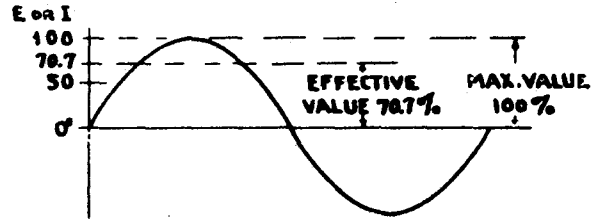

$$\text{POLES} = \frac{120 \times \text{FREQUENCY}}{\text{R.P.M.}}$$

$$\text{R.P.M.} = \frac{120 \times \text{FREQUENCY}}{\text{POLES}}$$

$$\text{FREQUENCY} = \frac{\text{POLES} \times \text{R.P.M.}}{120}$$



THIS SKETCH SHOWS THAT THE NUMBER OF LINES CUT PER SEC. DEPENDS UPON THE FIELD STRENGTH, CONDUCTOR SPEED AND THE ANGLE WHICH THE CONDUCTOR MOVES WITH RESPECT TO THE LINES OF FORCE.

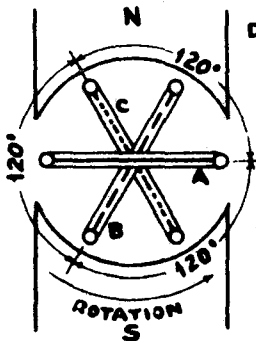

DEVELOPMENT OF VOLTAGE CURVES FOR A 3 PH. GEN.

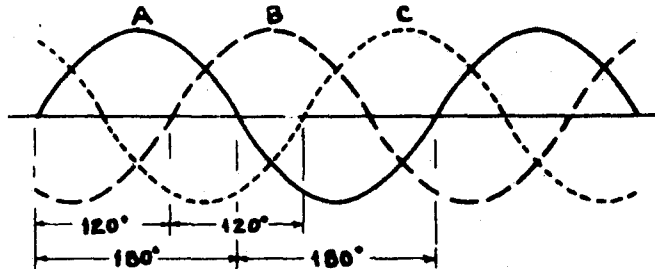
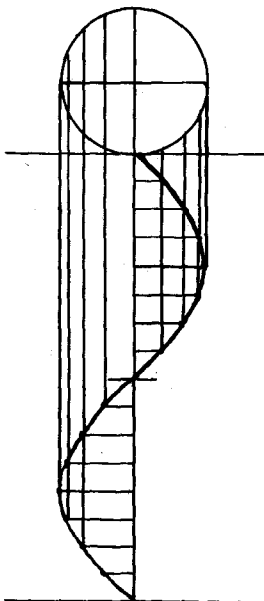
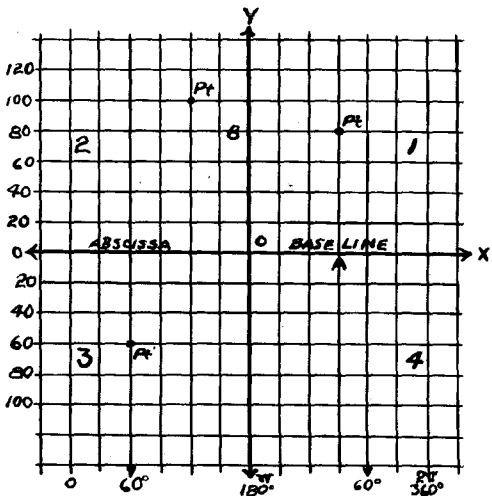
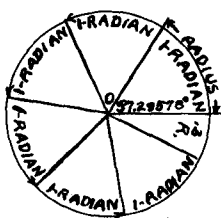
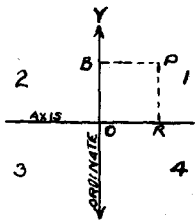
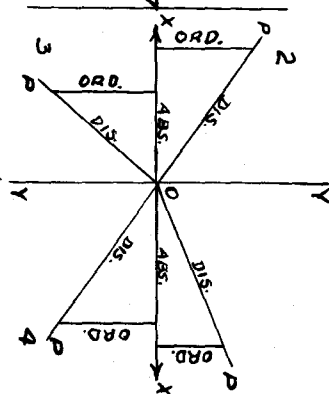
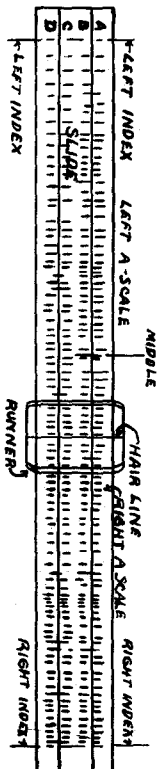

TABLE OF TRIGONOMETRIC FUNCTIONS.

USED FOR SOLVING PROBLEMS INVOLVING RIGHT ANGLE TRIANGLES.



QUADRANT	1	2	3	4
ABSCISSA	+	-	-	+
ORDINATE	+	+	-	-



ANGLE DEGREE	SIN.	SEC.	TAN.	COT.	CSC.	COS.	ANGLE DEGREE
0	.000	1.000	.000	∞	∞	1.000	90
1	.017	1.000	.017	57.290	57.299	1.000	89
2	.035	1.001	.035	28.636	28.654	.999	88
3	.052	1.001	.052	19.081	19.107	.999	87
4	.070	1.002	.070	14.301	14.336	.998	86
5	.087	1.004	.087	11.430	11.474	.996	85
6	.105	1.006	.105	9.514	9.567	.995	84
7	.122	1.008	.123	8.144	8.206	.993	83
8	.139	1.010	.141	7.155	7.185	.990	82
9	.156	1.012	.158	6.314	6.392	.988	81
10	.174	1.015	.176	5.671	5.759	.985	80
11	.191	1.019	.194	5.145	5.241	.982	79
12	.208	1.022	.213	4.705	4.810	.978	78
13	.225	1.026	.231	4.331	4.445	.974	77
14	.242	1.031	.249	4.011	4.134	.970	76
15	.259	1.035	.268	3.732	3.864	.966	75
16	.276	1.040	.287	3.487	3.628	.961	74
17	.292	1.046	.306	3.271	3.420	.956	73
18	.309	1.051	.325	3.078	3.236	.951	72
19	.326	1.058	.344	2.904	3.072	.946	71
20	.342	1.064	.364	2.747	2.924	.940	70
21	.358	1.071	.384	2.605	2.790	.934	69
22	.375	1.079	.404	2.475	2.669	.927	68
23	.391	1.086	.424	2.356	2.559	.921	67
24	.407	1.095	.445	2.246	2.469	.914	66
25	.423	1.103	.466	2.145	2.366	.906	65
26	.438	1.113	.488	2.050	2.281	.899	64
27	.454	1.122	.510	1.963	2.203	.891	63
28	.469	1.133	.532	1.881	2.130	.883	62
29	.485	1.143	.554	1.804	2.063	.875	61
30	.500	1.155	.577	1.733	2.000	.866	60
31	.515	1.167	.601	1.664	1.942	.857	59
32	.530	1.179	.625	1.600	1.887	.848	58
33	.545	1.192	.649	1.540	1.836	.839	57
34	.559	1.206	.675	1.483	1.788	.829	56
35	.574	1.221	.700	1.428	1.743	.819	55
36	.588	1.236	.727	1.376	1.701	.809	54
37	.602	1.252	.754	1.327	1.662	.799	53
38	.616	1.269	.781	1.280	1.624	.788	52
39	.629	1.287	.810	1.235	1.589	.777	51
40	.643	1.305	.839	1.192	1.556	.766	50
41	.656	1.325	.869	1.150	1.527	.755	49
42	.669	1.346	.900	1.111	1.494	.743	48
43	.682	1.367	.933	1.072	1.466	.731	47
44	.695	1.390	.966	1.036	1.440	.719	46
45	.707	1.414	1.000	1.000	1.414	.707	45
	COS	CSC	COT.	TAN.	SEC.	SIN.	

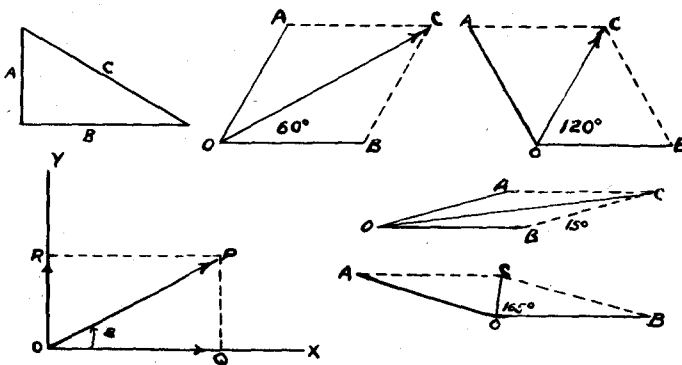

CONVENIENT TABLES AND FORMULAE

FORMULA FOR COMBINING RESISTANCE AND REACTANCE

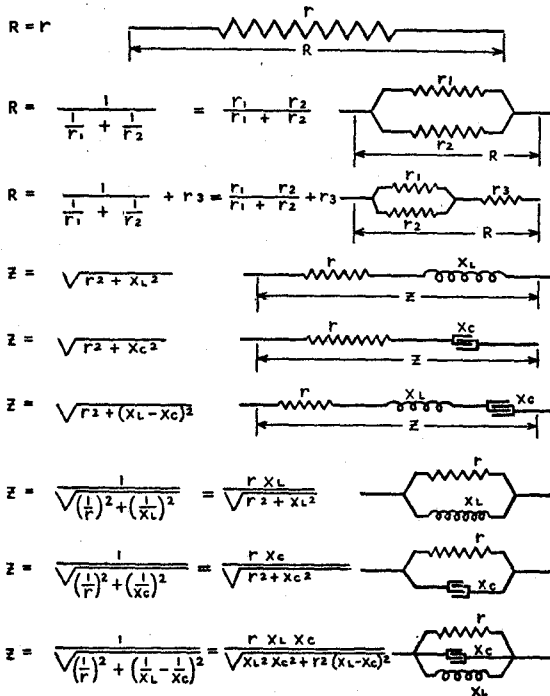

r = Resistance in Ohms
 X_L = Inductive reactance in Ohms = $2\pi fL$
 X_C = Condensive Reactance in Ohms = $\frac{1}{2\pi fC}$
 Z = Impedance in Ohms
 I = Current in Amperes
 E = Pressure in Volts
 f = frequency
 L = ind. in Henrys
 C = capacity in Farads

DETERMINATION OF TEMPERATURE by Resistance Measurements

Based on a temperature co-efficient for copper wire of .00427 at 0°C, the following relations exist between resistance and temperature:

R = Resistance of winding at T° C (Final Temp.)
 r = Resistance of winding at t° C (Initial Temp.)
 then $\frac{R}{r} = \frac{234.5 + T}{234.5 + t}$ or $T = \frac{R}{r}(234.5 + t) - 234.5$

HANDY FORMULAS

Power Transmission by Shaft

$Hp. = \frac{\text{Torque (in ft. lb.)} \times \text{Rpm.}}{5250}$

Hydraulics

Hp. of Water Fall = .114 x cu. ft. per sec. x head in ft. x Eff. Assuming 88% eff. of water wheel, then:
 100 cu. ft. per sec. with 10 ft. head = 100 Hp.

Power to Drive Pumps

$Hp. = \frac{\text{Gal. per min.} \times \text{Total head (inc. friction)}}{3960 \times \text{Eff. of Pump}}$

Fans and Blowers

Hp. to drive fans = $\frac{K \times \text{cu. ft. min.} \times \text{water gage pressure in in.}}{33000 \times \text{Eff. of fan}}$
 Water gage inches = 1.728 oz. per sq. in.
 $K = 5.2$
 Eff. = .5 for ordinary fans to .65 for Sirocco type

Rotating Mass Formula

Useful in estimating time to start-stop or change speed of fly-wheels, motors, etc. with certain applied torque =
 Time (Sec.) = $\frac{WR^2 \times \text{change in Rpm.}}{322 \times \text{torque (ft. lb.)}}$

MENSURATION OF SURFACES AND VOLUMES

Area of Rectangle = length x breadth.
 Area of Triangle = $\frac{1}{2}$ base x perpendicular height.
 Circumference of Circle = diameter x 3.1416.
 Area of Circle = square of diameter x .7854.

To Find Diameter of a Circle of Given Area

Divide area by .7854 and extract square root.

To Find Volume of a Cylinder

Area of section in square inches x length in inches = Volume in cubic inches.
 Cubic inches + 1728 = Volume in cubic feet.
 Surface of a Sphere = Square of diam. x 3.1416.
 Volume of a Sphere = Cube of diam. x .5236.
 Diameter x .8862 = Side of square of equal area.
 Diameter x .7071 = Side of inscribed square.
 Circumference = 3.5449 x $\sqrt{\text{area of circle.}}$
 Diameter = 1.1284 x $\sqrt{\text{area of circle.}}$

USEFUL ELECTRICAL FORMULAE FOR DETERMINING AMPERES, HORSEPOWER, KILOWATTS, AND Kv-a.

To Find	Direct Current	ALTERNATING CURRENT		
		Single Phase	2 Phase *—Four Wire	Three Phase
Amperes when Horsepower is known	$\frac{Hp. \times 746}{E \times \% \text{ Eff.}}$	$\frac{Hp. \times 746}{E \times \% \text{ Eff.} \times \text{P.F.}}$	$\frac{Hp. \times 746}{2 \times E \times \% \text{ Eff.} \times \text{P.F.}}$	$\frac{Hp. \times 746}{1.73 \times E \times \% \text{ Eff.} \times \text{P.F.}}$
Amperes when Kilowatts is known	$\frac{Kw. \times 1000}{E}$	$\frac{Kw. \times 1000}{E \times \text{P.F.}}$	$\frac{Kw. \times 1000}{2 \times E \times \text{P.F.}}$	$\frac{Kw. \times 1000}{1.73 \times E \times \text{P.F.}}$
Amperes when Kv-a. is known		$\frac{Kv-a. \times 1000}{E}$	$\frac{Kv-a. \times 1000}{2 \times E}$	$\frac{Kv-a. \times 1000}{1.73 \times E}$
Kilowatts	$\frac{I \times E}{1000}$	$\frac{I \times E \times \text{P.F.}}{1000}$	$\frac{I \times E \times 2 \times \text{P.F.}}{1000}$	$\frac{I \times E \times 1.73 \times \text{P.F.}}{1000}$
Kv-a.		$\frac{I \times E}{1000}$	$\frac{I \times E \times 2}{1000}$	$\frac{I \times E \times 1.73}{1000}$
Horsepower—(output)	$\frac{I \times E \times \% \text{ Eff.}}{746}$	$\frac{I \times E \times \% \text{ Eff.} \times \text{P.F.}}{746}$	$\frac{I \times E \times 2 \times \% \text{ Eff.} \times \text{P.F.}}{746}$	$\frac{I \times E \times 1.73 \times \% \text{ Eff.} \times \text{P.F.}}{746}$

I = Amperes; E = Volts; % Eff. = Percent Efficiency; P.F. = Power Factor; Kw. = Kilowatts; Kv-a. = Kilovolt-amperes; Hp. = Horsepower.

* For three-wire, two-phase circuits the current in the common conductor is 1.41 times that in either of the other two conductors.

POWER FACTOR CORRECTION

Low power factor increases the Kv-a. rating required in generating equipment, switchgear, lines, and transformers, and not only prevents the generation of maximum Kw. but increases the losses in all current carrying parts, resulting in poor voltage regulation over the entire system. Various types of apparatus are available for improving power factor, but synchronous motors and static condensers have proven themselves to be most satisfactory. The synchronous motor, in addition to correcting power factor, may be used to carry a mechanical load. Static condensers have no moving parts, require no maintenance other than occasional inspection, and may be installed in out-of-the-way locations.

The best method of correcting power factor in a given case can only be determined by a careful study of surrounding conditions. Without taking into consideration special features, the amount of corrective Kv-a. may be determined as follows:

- Present { (a) $\frac{KW}{P.F.} = KVA$
 (b) Reactive KVA = $\sqrt{KVA^2 - KW^2}$
 Desired { (c) $\frac{KW}{P.F.} = KVA$
 (d) Reactive KVA = $\sqrt{KVA^2 - KW^2}$
 (b)-(d) = Corrective KVA required

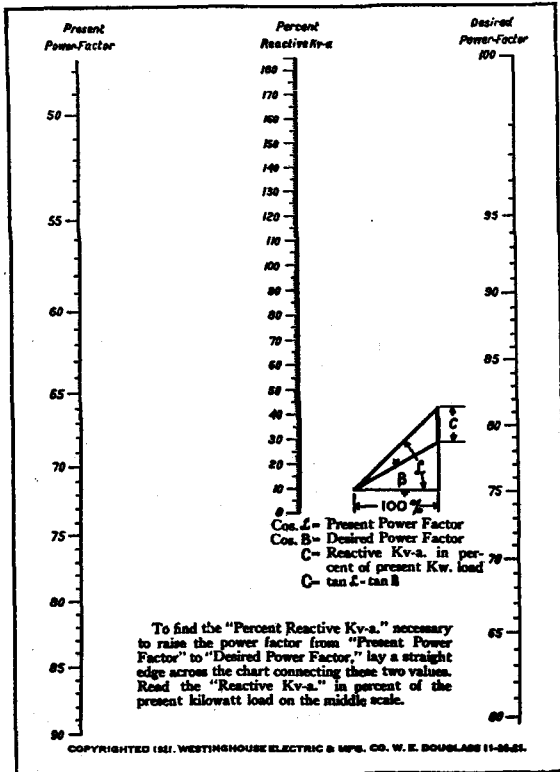

APPROX. AMPERES FOR INDUCTION MOTORS

Hp. of Motor	220 VOLTS		Hp. of Motor	220 VOLTS	
	2-Ph.	3-Ph.		2-Ph.	3-Ph.
.5	1.7	2.0	50.	108.	125.
1.0	3.0	3.5	60.	130.	150.
2.0	5.5	6.4	75.	160.	185.
3.0	8.0	9.2	100.	215.	250.
5.0	13.	15.	125.	260.	300.
7.5	19.	22.	150.	320.	370.
10.	24.	28.	175.	360.	420.
15.	35.	40.	200.	415.	480.
20.	45.	52.	225.	460.	530.
25.	56.	65.	250.	520.	600.
30.	66.	75.	275.	570.	660.
40.	87.	100.	300.	620.	720.

For 110 volts, use 2; for 440, use 1/2; for 550, use 3/4; for 1100, use 3/2; and for 2200, use 3/4 of the above values. For single phase motors use twice the value for two phase motors.

FORMULA FOR DETERMINING ALTERNATING CURRENT in Alternating Current Circuits

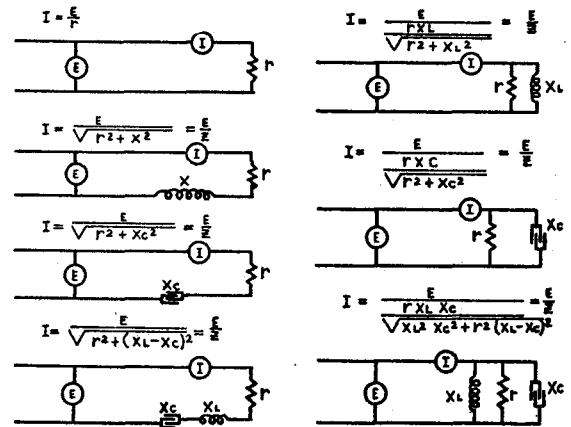

r = Resistance in Ohms
 XL = Inductive reactance in Ohms = $2\pi fL$
 XC = Condensive Reactance in Ohms = $\frac{1}{2\pi fC}$
 Z = Impedance in Ohms
 I = Current in Amperes
 E = Pressure in Volts

f = frequency
 L = ind. in Henrys
 C = capacity in Farads

CONDUIT SIZES

The Following Table Applies Only to Complete Conduit Systems, and Does Not Apply to Short Sections of Conduit Used for the Protection of Exposed Wiring From Mechanical Injury.
TWO-WIRE AND THREE-WIRE SYSTEMS

Size of Wire	NUMBER OF WIRES IN ONE CONDUIT									Size of Wire	NUMBER OF WIRES IN ONE CONDUIT								
	1	2	3	4	5	6	7	8	9		1	2	3	4	5	6	7	8	9
	MINIMUM SIZE OF CONDUIT IN INCHES										MINIMUM SIZE OF CONDUIT IN INCHES								
No. 12	1/2	1/2	1/2	1/2	3/4	1	1 1/4	1 1/2	1 3/4	550,000	1 1/2	3	3 1/2	4	4 1/2	5	
10	1/2	3/4	3/4	3/4	1	1 1/4	1 1/2	1 3/4	1 3/4	600,000	2	3	3 1/2	4	4 1/2	5	
8	3/4	3/4	3/4	3/4	1	1 1/4	1 1/2	1 3/4	1 3/4	650,000	2	3 1/2	3 1/2	4	
6	3/4	1	1 1/4	1 1/4	1 1/2	1 3/4	2	2	2	700,000	2	3 1/2	3 1/2	4 1/2	
5	3/4	1 1/4	1 1/4	1 1/4	1 1/2	2	2	2	2	750,000	2	3 1/2	3 1/2	4 1/2	
4	3/4	1 1/4	1 1/4	1 1/4	2	2	2	2	2 1/4	800,000	2	3 1/2	4	4 1/2	
3	3/4	1 1/4	1 1/4	1 1/4	2	2	2	2	2 1/2	850,000	2	3 1/2	4	4 1/2	
2	3/4	1 1/4	1 1/4	1 1/4	2	2	2	2 1/2	2 1/2	900,000	2	3 1/2	4	4 1/2	
1	3/4	1 1/2	1 1/2	2	2	2 1/2	2 1/2	3	3	950,000	2	4	4	5	
0	1	1 1/2	2	2	2 1/2	2 1/2	3	3	3	1,000,000	2	4	4	5	
00	1	2	2	2 1/2	2 1/2	3	3	3	3 1/2	1,100,000	2 1/2	4	4 1/2	6	
1	1	2	2	2 1/2	3	3	3	3 1/2	3 1/2	1,200,000	2 1/2	4 1/2	4 1/2	6	
000	1 1/4	2	2 1/2	2 1/2	3	3	3 1/2	3 1/2	4	1,250,000	2 1/2	4 1/2	4 1/2	6	
0000	1 1/4	2	2 1/2	2 1/2	3	3	3 1/2	3 1/2	4	1,300,000	2 1/2	4 1/2	5	6	
200,000 C.M.	1 1/4	2	2 1/2	2 1/2	3	3	3 1/2	3 1/2	4	1,400,000	2 1/2	4 1/2	5	6	
225,000	1 1/4	2 1/2	2 1/2	3	3	3 1/2	1,500,000	2 1/2	4 1/2	5	6	
250,000	1 1/4	2 1/2	2 1/2	3	3	3 1/2	1,600,000	2 1/2	5	5	6	
300,000	1 1/4	2 1/2	3	3	3 1/2	3 1/2	1,700,000	3	5	5	6	
350,000	1 1/4	2 1/2	3	3 1/2	3 1/2	4	1,750,000	3	5	5	6	
400,000	1 1/4	3	3	3 1/2	4	4	1,800,000	3	5	5	6	
450,000	1 1/4	3	3	3 1/2	4	4 1/2	1,900,000	3	5	6	

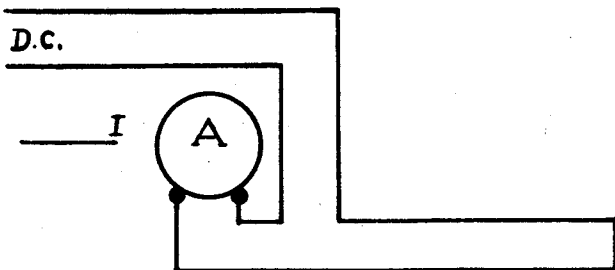

$$I = \frac{E}{R} = \text{---} = I$$

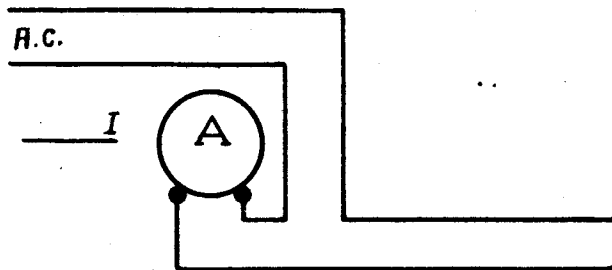

$$I = \frac{E}{R} = \text{---} = I$$

In D.C. circuits resistance is the only opposition encountered by I flow, therefore, the I is proportional to the E applied, or inversely proportional to the resistance of the circuit. OHMS LAW for D.C. also applies to A.C. circuits containing resistance only, and is approximately correct.

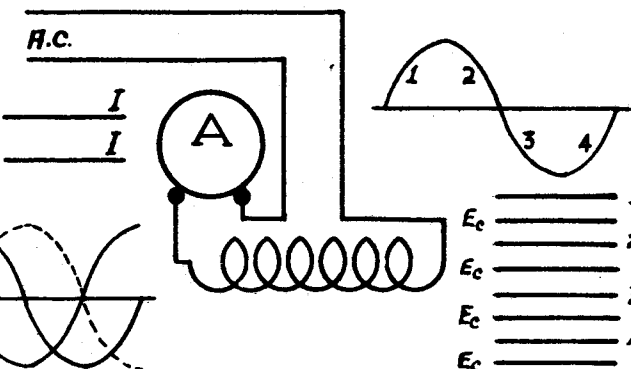
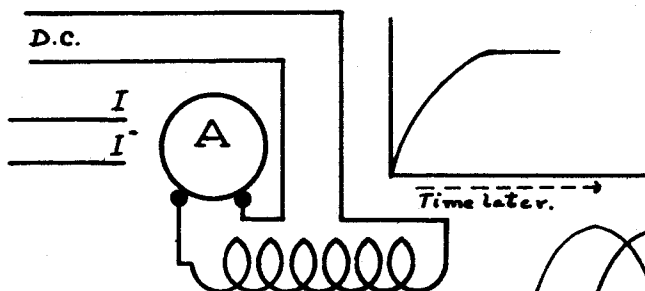

Inductance effects exist in D.C. circuits only during I changes. The I is opposed by a self induced E generated by the expanding magnetic field. This E does not exist when the flux becomes stationary.

INDUCTIVE REACTANCE is a C.E.M.F. generated in the A.C. circuit of inductive nature by the expanding and contracting magnetic field set up by the varying A.C. Its symbol is X_L and its value is measured in ohms. X_L has 2 effects in the A.C. circuit: 1. it opposes I flow. 2. It causes the I to lag the applied E by almost 90° . X_L varies as the frequency. The E applied to apparatus designed for one frequency must be changed in the same proportion when operated on another frequency.

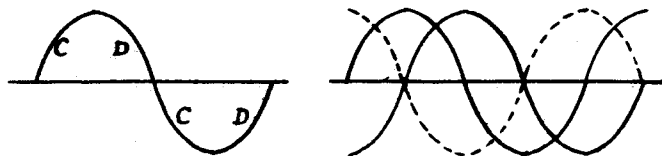
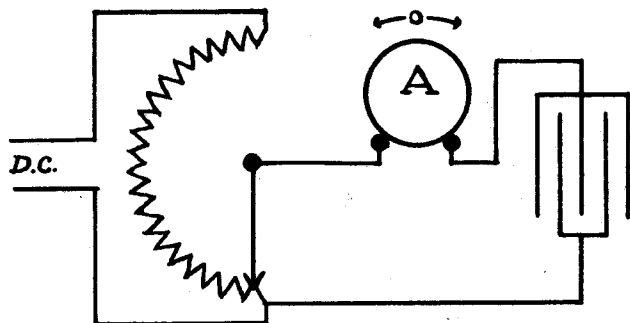

CAPACITY REACTANCE is the opposition offered to the flow of an A.C. by a condenser. Its symbol is X_C , and its value is measured in ohms. X_C has 2 effects in the A.C. circuit: 1. It opposes I flow. 2. It causes the I to lead the applied E by almost 90° . X_C varies inversely as the frequency. When a condenser is to be operated on a higher frequency, frequency is increased.

OPPOSITION TO CURRENT IN THE A.C. CIRCUIT. #2.

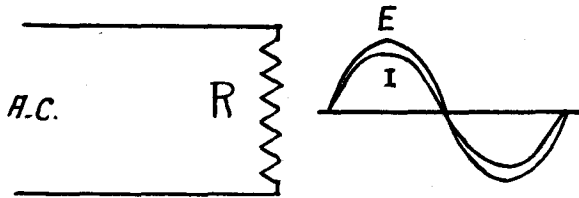

In a circuit of resistance only the I will be in phase with the E, since there is no reactance present to cause the I to lag or lead the E applied.

IMPEDANCE is the total opposition offered to the flow of an A.C. Its symbol is Z, and its value is measured in OHMS. Z may consist of R only, X_L only, X_c only, or any combination of these effects.

OHMS LAW for A.C. - The I is proportional to the E applied, and inversely proportional to the IMPEDANCE of the circuit.

$$Z = \frac{E}{I}, \quad I = \frac{E}{Z}, \quad E = I \times Z.$$

- X_L is 90° out of phase with R.
- X_c is 90° out of phase with R.
- X_L is 180° out of phase with X_c .

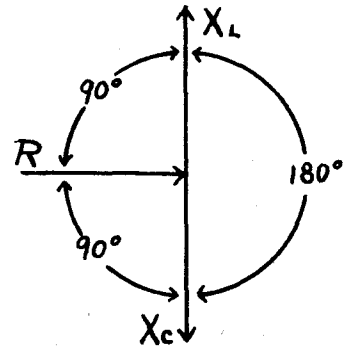

A.C. quantities must be added geometrically when out of phase with each other. They may be added by simple arithmetic only when they are in phase with each other.

EXAMPLES FOR IMPEDANCE IN A SERIES CIRCUIT.

R and X_L in series.

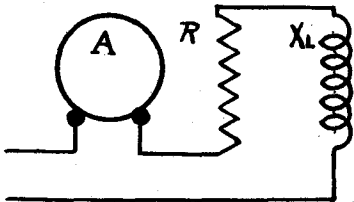

$$Z = \sqrt{R^2 + X_L^2}$$

$$\sqrt{\begin{matrix} 2 & + & 2 \\ 2 & + & 2 \end{matrix}}$$

$$\sqrt{\quad + \quad}$$

$$\sqrt{\quad} = Z$$

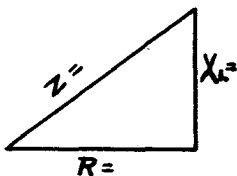

$E_L = \text{Line } E$

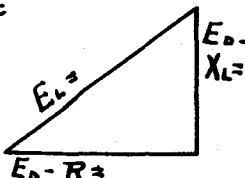

Scale = 1 Unit Per Inch

R and X_c in series.

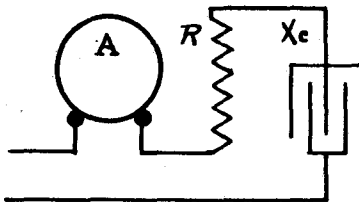

$$Z = \sqrt{R^2 + X_c^2}$$

$$\sqrt{\begin{matrix} 2 & + & 2 \\ 2 & + & 2 \end{matrix}}$$

$$\sqrt{\quad + \quad}$$

$$\sqrt{\quad} = Z$$

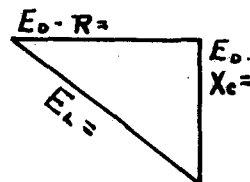
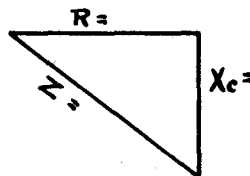

Scale = 1 Unit Per Inch

R, X_L , and X_c in series.

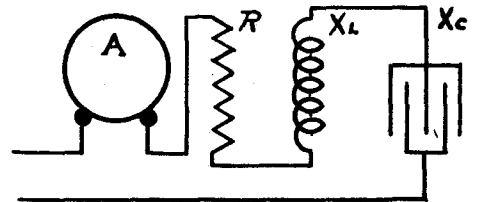

$$Z = \sqrt{R^2 - (X_L - X_c)^2}$$

$$\sqrt{\begin{matrix} 2 & (& - &)^2 \\ 2 & (& - &)^2 \end{matrix}}$$

$$\sqrt{\quad + \quad}$$

$$\sqrt{\quad} = Z$$

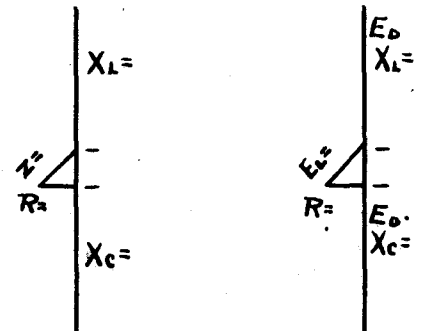

Scale = 1 Unit Per Inch

READ THE FOLLOWING INSTRUCTIONS CAREFULLY. FAILURE TO DO SO MAY RUIN THE AMMETER.

CONNECT THE RESISTANCE, INDUCTIVE REACTANCE, AND CAPACITY REACTANCE IN SERIES AS SHOWN IN THE DIAGRAM. ADJUST THE RESISTANCE (WATER RHEOSTAT) UNTIL AMMETER REGISTERS EXACTLY 20 AMPERES. WITH VOLTMETER, MEASURE THE VOLTAGE DROP ACROSS EACH UNIT IN THE SERIES CIRCUIT.

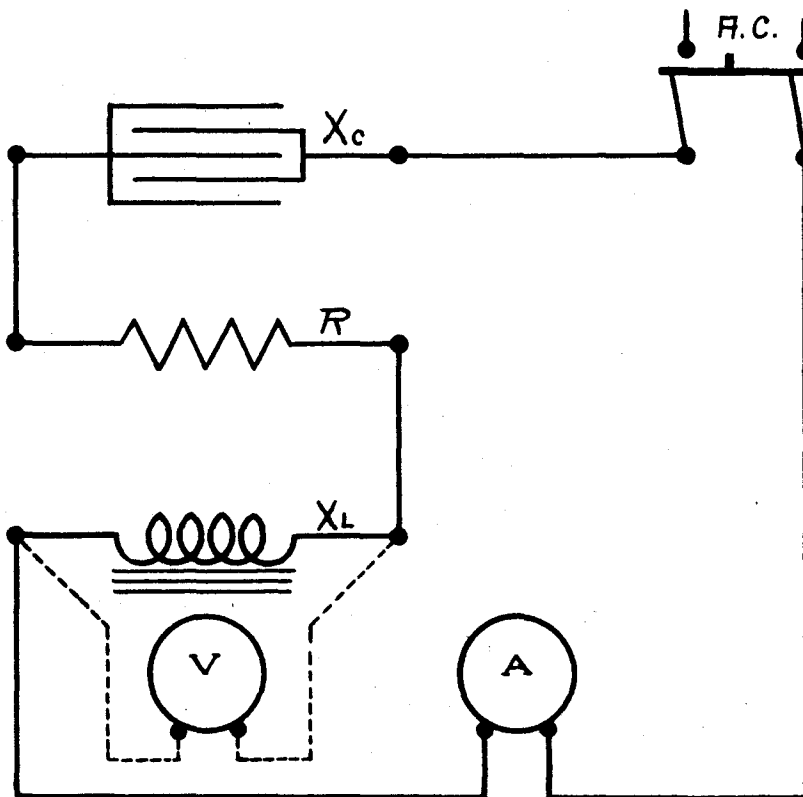

$$X_c = \frac{\text{Voltage drop across } X_c}{\text{Amperes}} = \quad = X_c$$

$$R = \frac{\text{Voltage drop across } R}{\text{Amperes}} = \quad = R$$

$$X_L = \frac{\text{Voltage drop across } X}{\text{Amperes}} = \quad = X_L$$

After obtaining the above values of X_c , R and X_L , the total IMPEDANCE may be determined as follows:

$$(1) Z = \sqrt{R^2 + (X_L - X_c)^2}$$

$$(4) Z = \sqrt{\quad + \quad}$$

$$(2) Z = \sqrt{\quad^2 + (\quad - \quad)^2}$$

$$(5) Z = \sqrt{\quad^2 + \quad^2}$$

$$(3) Z = \sqrt{\quad^2 + \quad^2}$$

$$(6) Z = \quad$$

The value of Z obtained above may be checked by dividing the line voltage by the ammeter reading. Errors in the instruments and in meter readings will probably cause some variation between the two values. Test by using the following formula:

$$Z = \frac{\text{Line voltage}}{\text{Amperes}} = \quad = Z.$$



PHASING OUT, SYNCHRONIZING AND PARALLELING OF A.C. GENERATORS

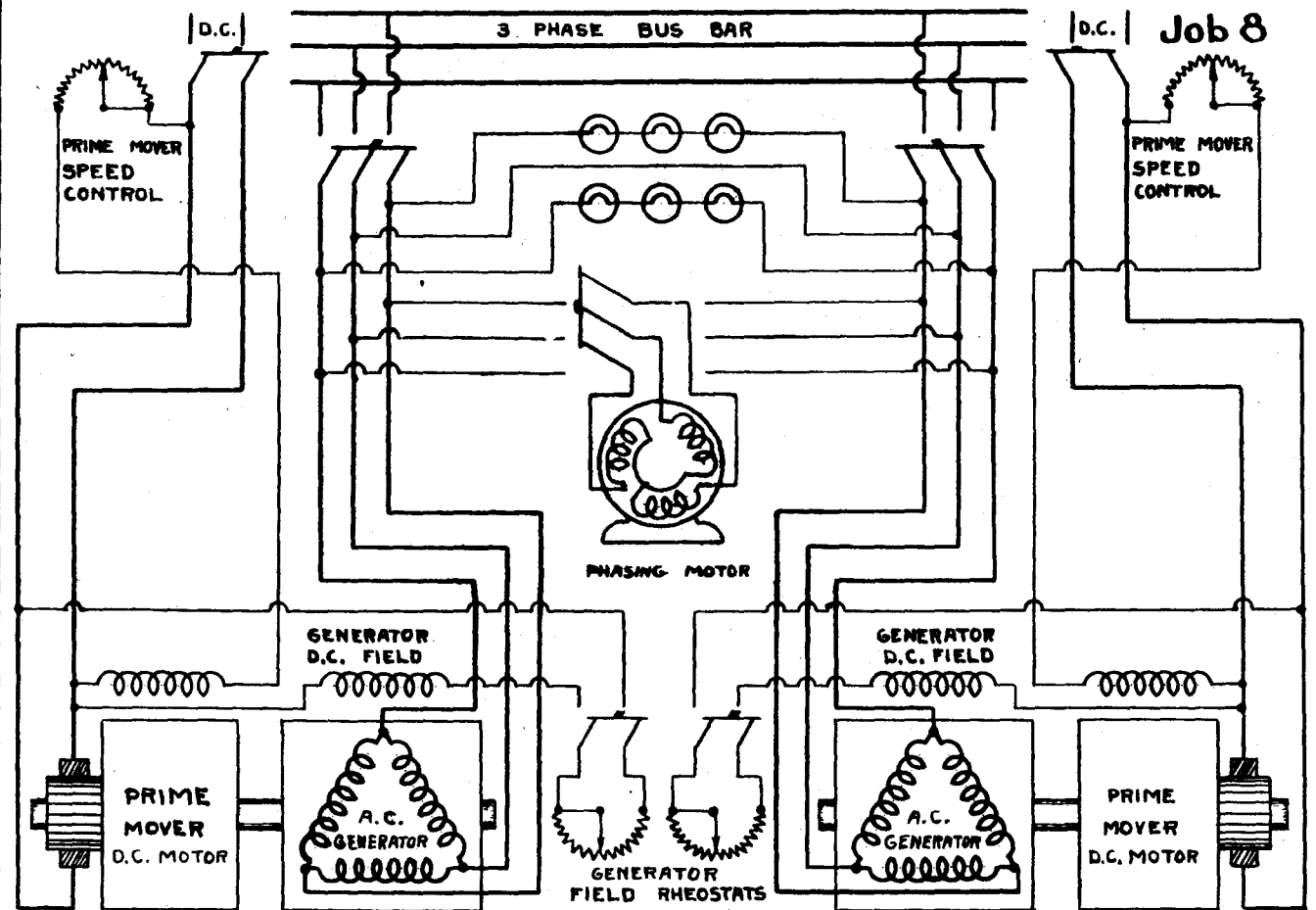

TO OPERATE SATISFACTORILY WHEN SWITCHED IN PARALLEL, A.C. GENERATORS MUST FULFILL THE FOLLOWING REQUIREMENTS:

1. The machines must be designed for the same voltage and frequency. They need not have the same speed or the same power rating.
2. The generators must have similar operating characteristics as far as voltage regulation is concerned in order to assure proper division of load.
3. The machines must be correctly connected together, or "phased out."

The paralleling switch must be closed at the instant when the generator frequencies are very nearly equal, and when the voltages are exactly equal and in direct opposition to each other. These conditions exist when the voltmeters read alike and the synchronizing lamps are out. Under such circumstances, the generators are said to be in synchronism - this is the instant at which the paralleling switch must be closed.

"Phasing out" may be effected by strings of lamps, or a three-phase motor, connected as indicated. If the generators are properly connected, all lights will go out together, and the phasing motor will run in the same direction on either machine. Should the action of the lamps or the operation of the motor indicate an improper connection, interchange any two leads of the new machine. It is important to note that the strings of lights or the phasing motor - whichever is used - must be symmetrically connected with respect to the generators if trustworthy indications are to be obtained. The above sketch shows how these devices should be connected.

After the new machine is in parallel, it must be caused to assume its proper share of the load. This can be accomplished by increasing the power input to the prime mover. Varying the field excitation on an A.C. generator will not cause it to pick up or drop load as it does with a D.C. machine. Instead, it merely results in changing the power factor of the machine. Although the new machine has to be "phased out" but once, the synchronizing operation must be repeated each time a generator is paralleled with others.

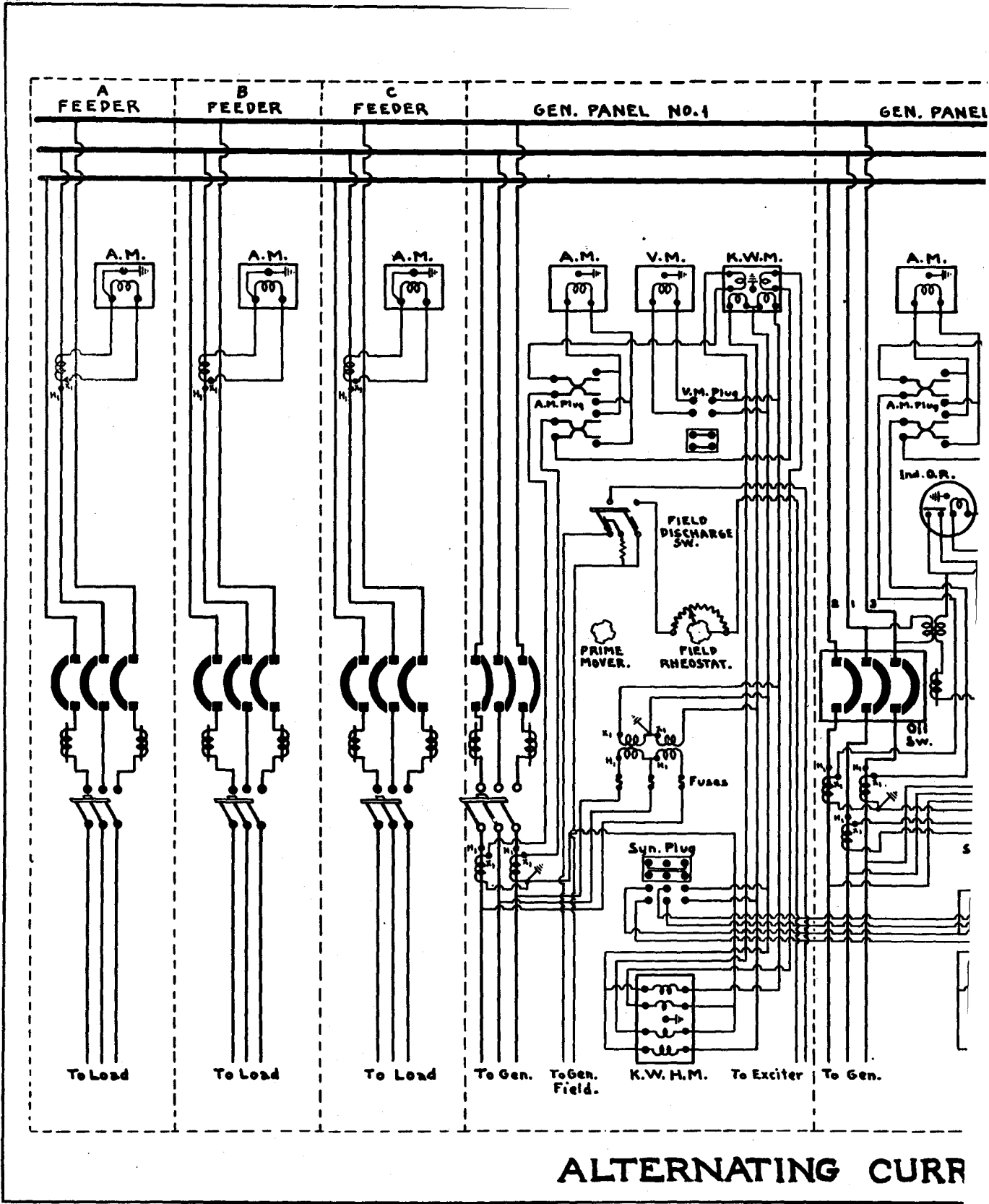

ALTERNATING CURR

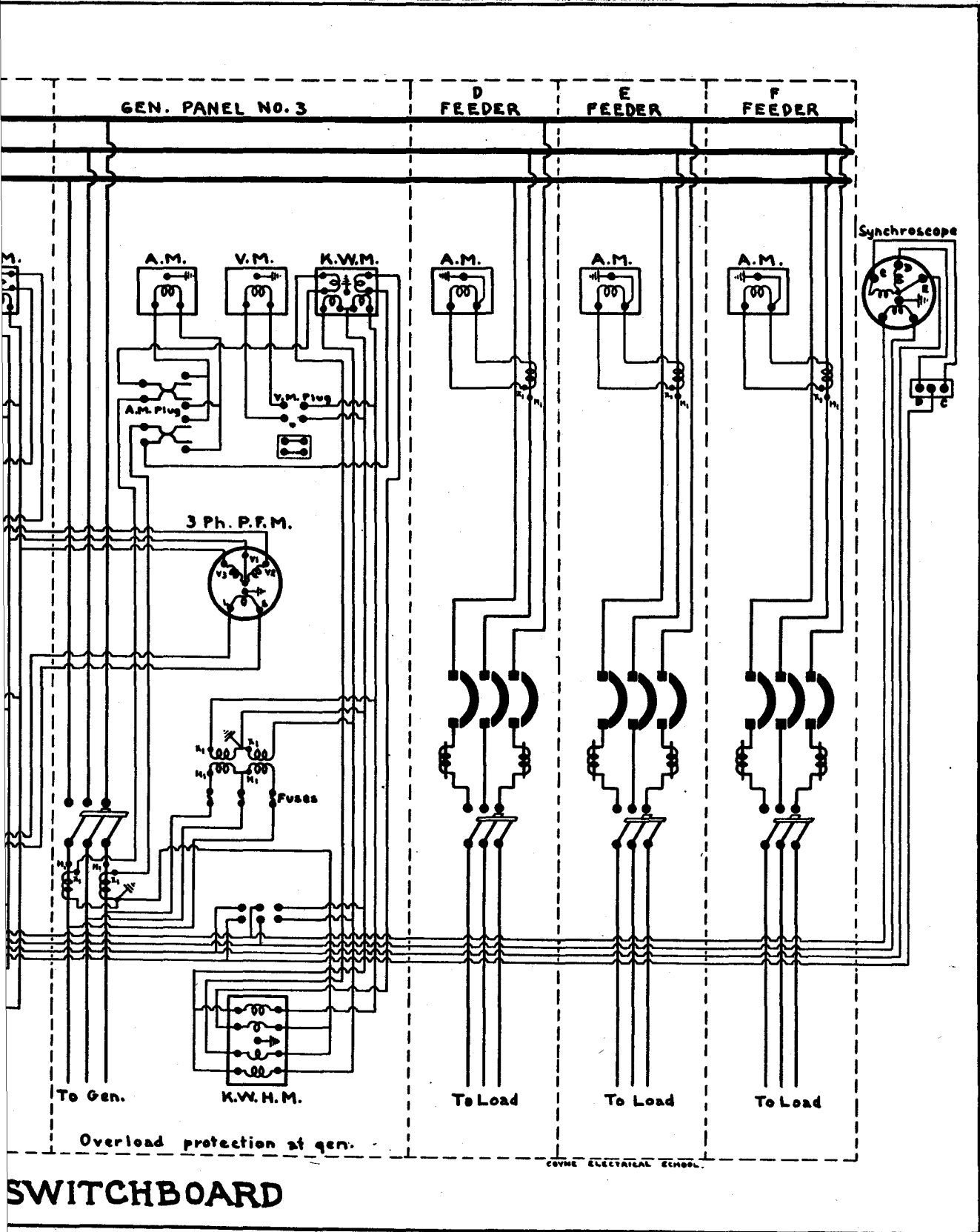

SWITCHBOARD

A.C. GENERATORS

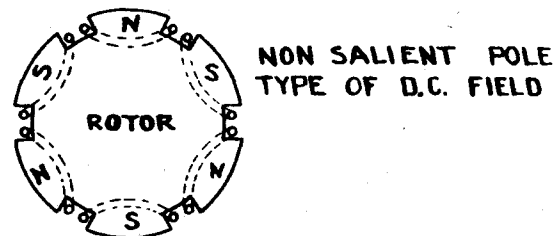
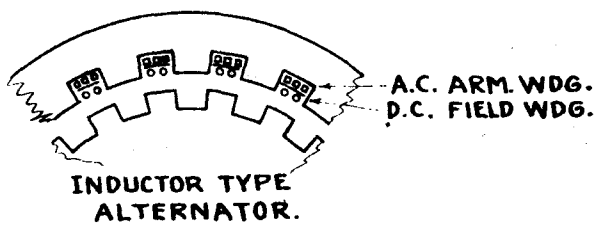
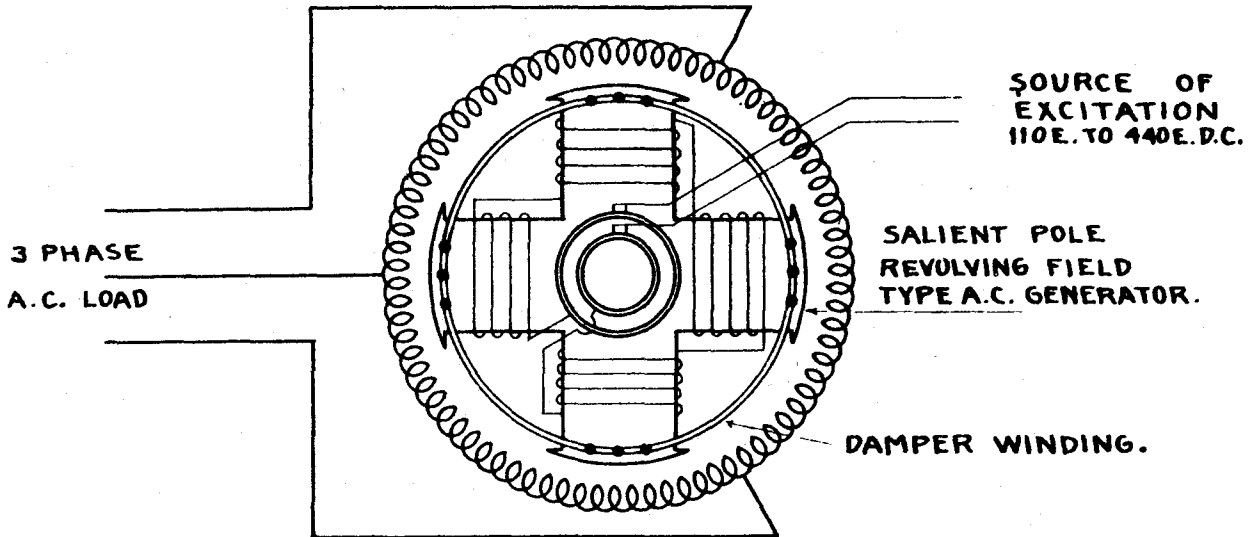

PARALLELING A.C. GENERATORS

220 E. 60~ 3PH BUS BARS.

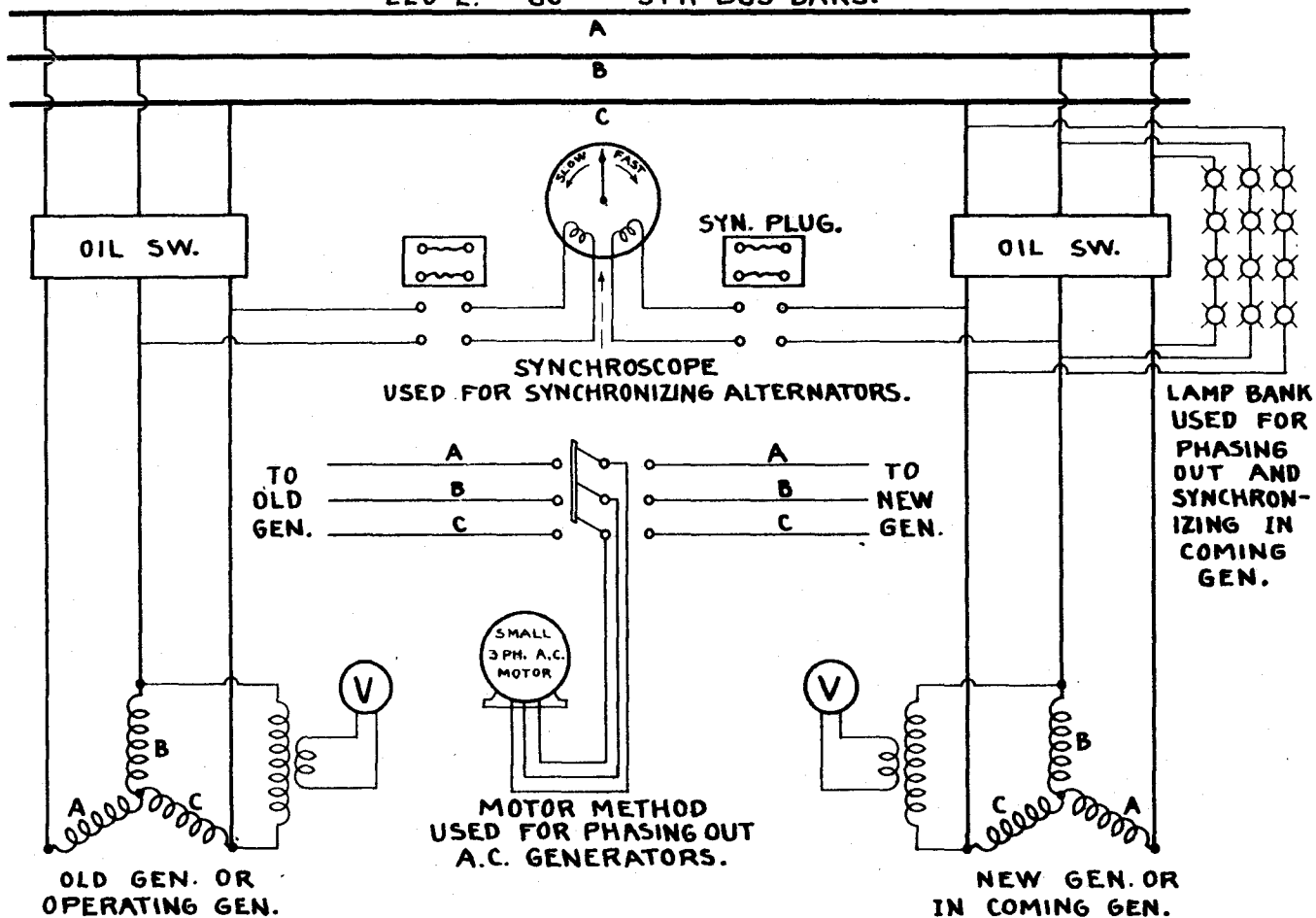

A.C. MOVING IRON TYPE AMMETER & VOLTMETER

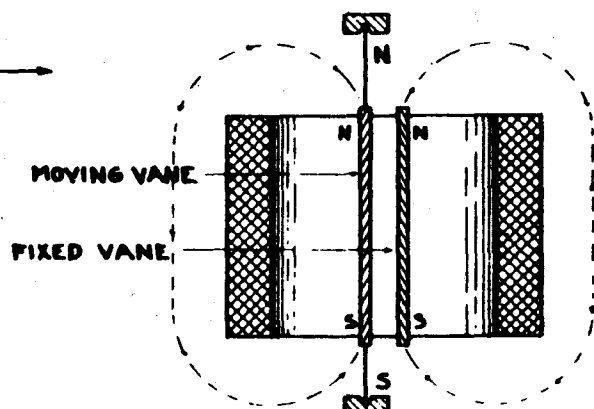
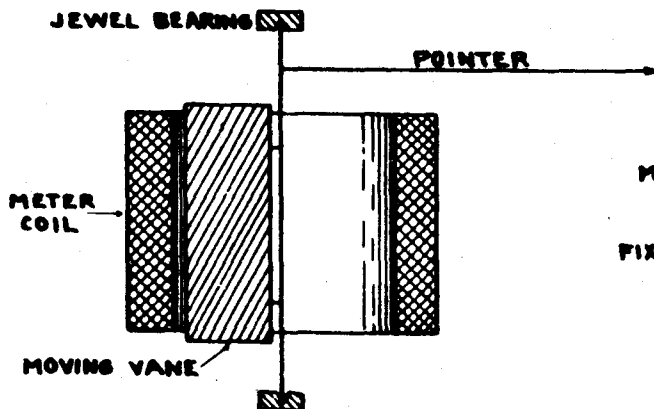
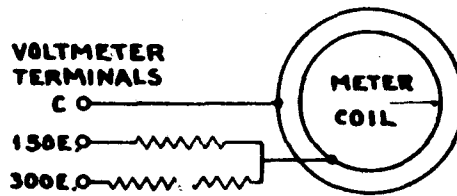
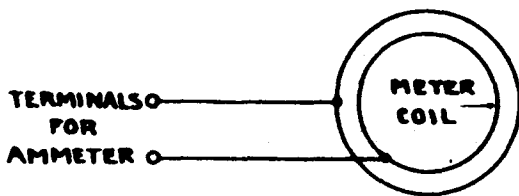
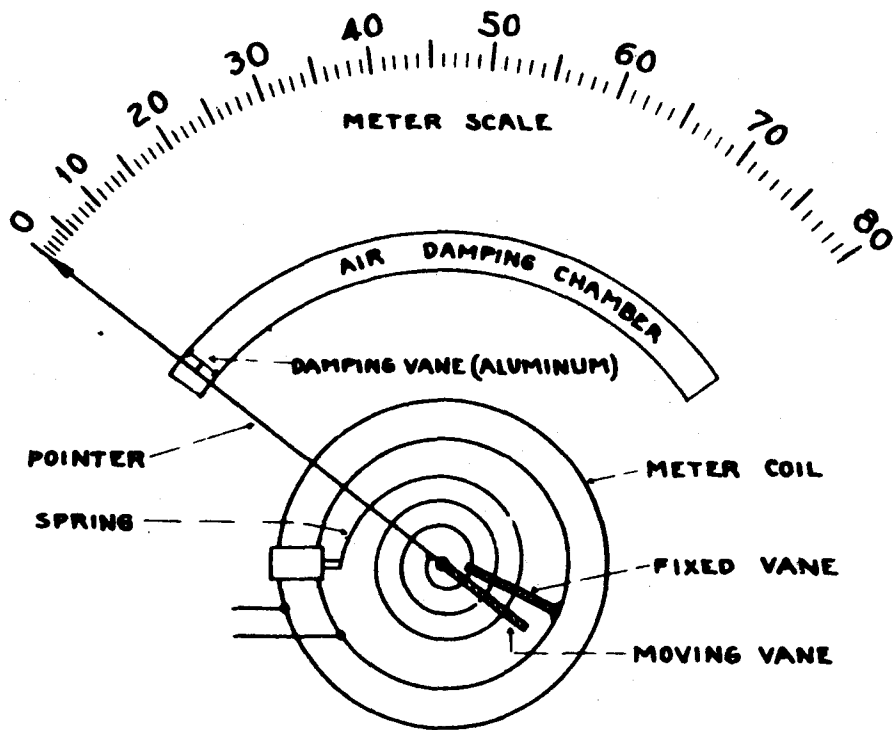

VANES ABOUT 1" LONG AND $\frac{2}{8}$ " TO $\frac{3}{4}$ " DEEP
REPULSION OF VANES

MEASUREMENT OF THREE PHASE POWER

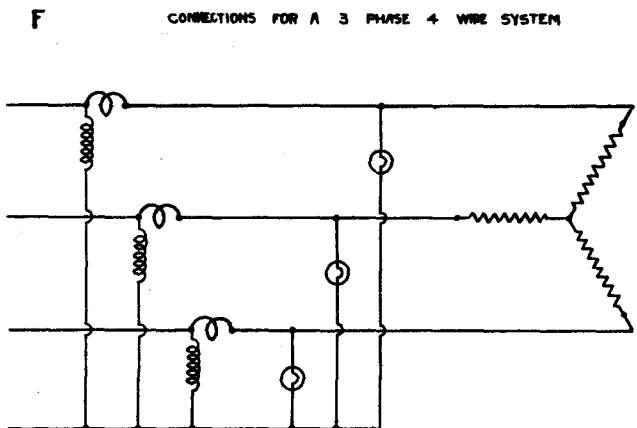
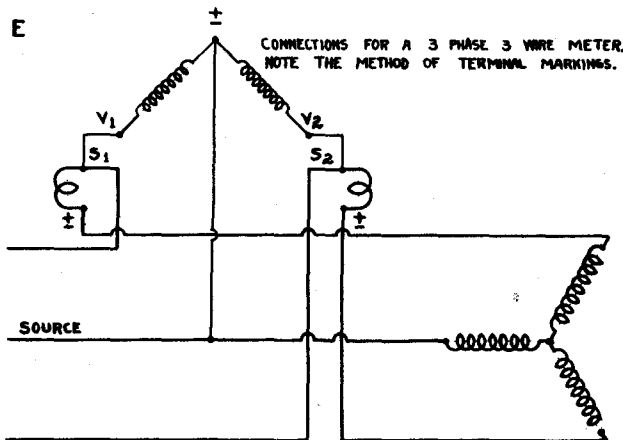
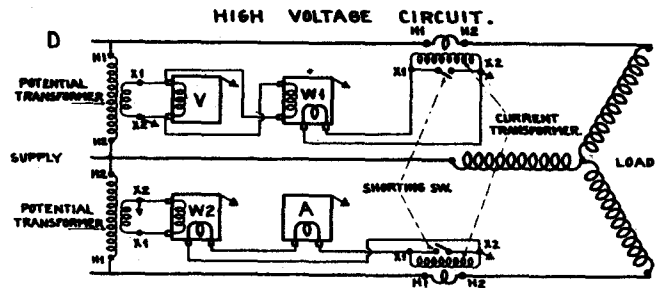
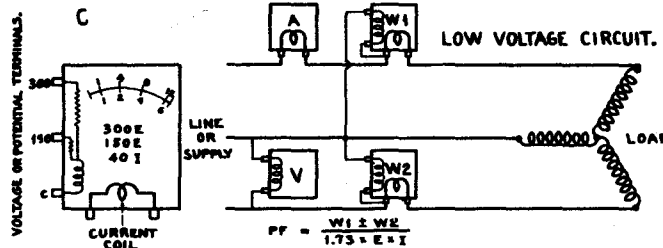
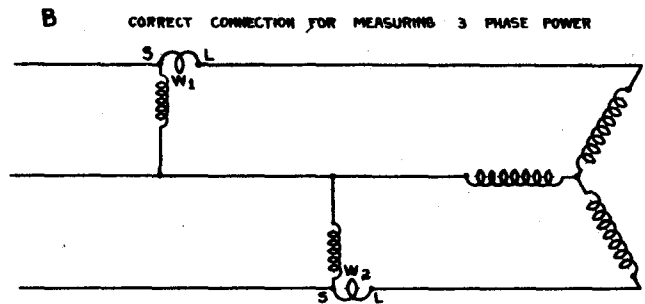
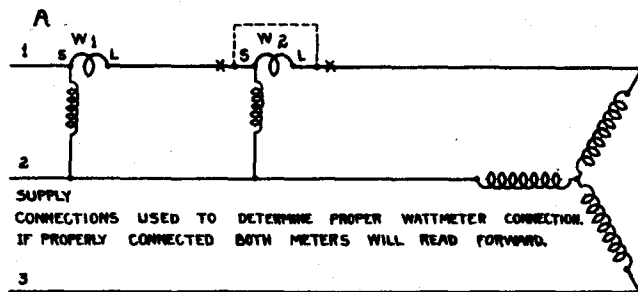

Measurement of power in the 3-phase, 3-wire circuit usually demands the use of at least two single-phase wattmeters, and these meters must be correctly connected to the circuit if accurate indications are to be obtained. Inasmuch as a 3-phase wattmeter is nothing more than two individual single-phase wattmeters in the same case, the same connection scheme will apply.

To correctly connect two single-phase wattmeters to a 3-phase, 3-wire circuit, proceed as follows: (1) Arrange meters as shown in sketch "A" with the individual current coils in series in the same lines. (2) Now check the meters and see if they both read alike; if they do not, one or both of the meters are inaccurate, since they are both measuring the same load. If one meter reads backward, reverse the voltage coil leads. (3) Disconnect wattmeters W2 at X-X and, without disturbing the voltage coil connections, insert the current coil in line 3, taking care not to change the position of the terminals "S" and "L" with respect to the circuit. The "S" terminal should still be attached to the source and the "L" terminal to the load end of the line.

The meters are now correctly connected in the circuit, and the total power taken by the load is equal to the sum of the wattmeter reading. In this regard, it should be observed that the meters will not read alike even upon a perfectly balanced load unless the power factor of the circuit is exactly 100%. As the power factor falls below this value, one meter will indicate a smaller and the other a larger percentage of the total load. At 50% P.F., one meter will indicate the total load and the other will read zero, and as the P.F. falls below this mark, the low meter will start to read backwards. As this reading indicates negative power, it must be subtracted from the reading of the other meter if the true power is to be obtained. Since the backward reading is unintelligible, reverse the voltage coil on the backward reading meter to obtain a forward reading, and then subtract this from the indication on the other unit.

When a 3-phase, 4-wire circuit is to be metered, three wattmeters, connected as shown at "B", are most frequently used. A current coil of each instrument is inserted in series with one line wire and the voltage coils are connected from the separate line wires to neutral as shown. The total power is the sum of the wattmeter readings. A change in power factor will not effect the relative values here as it does in the two-meter arrangement, the meters always reading forward regardless of the power factor value.

The wattmeters show, of course, the true power in watts absorbed by the circuit and, due to the fact the current required to carry a given wattage may be relatively high when the power factor of the circuit is low, there is danger of burning out the current coil of the wattmeter on low power factor loads. To prevent this, it is usual to connect an ammeter in series with the current coil of the meter to make sure that its rating is not exceeded.

If an ammeter and voltmeter are used in conjunction with the wattmeter, the total voltamperes and total watts may be measured, and from these the total power factor of the circuit may be computed by the formula shown. This is true for any circuit, a voltmeter, ammeter, and wattmeter being sufficient to determine the P.F. of any A.C. circuit.

On circuits of high voltage or great power, current and voltage transformers are used to (1) step down the quantities to be measured and (2) isolate the meters from the line. See Fig. D. Such transformers allow the use of smaller and cheaper instruments and at the same time eliminate the hazard associated with the reading and possible handling of meters attached to high voltage circuits. As shunts cannot be used with A.C. ammeters, extension of the meter range is accomplished by a current transformer which sends a small fraction of the line current through the meter. The actual current flowing through such meters never exceeds 5 amperes; however, the meter is calibrated to indicate the actual line current. Due to the peculiar action of the current transformer, its secondary circuit may never be opened while the unit is energized, as voltages of a dangerously high value appear across the secondary when this circuit is broken. The special short-circuiting switch is provided on these units to make possible the insertion and removal of meters without disconnecting the secondary circuit. Note that the cases of all meters are grounded.

RECTIFIERS & CONVERTERS

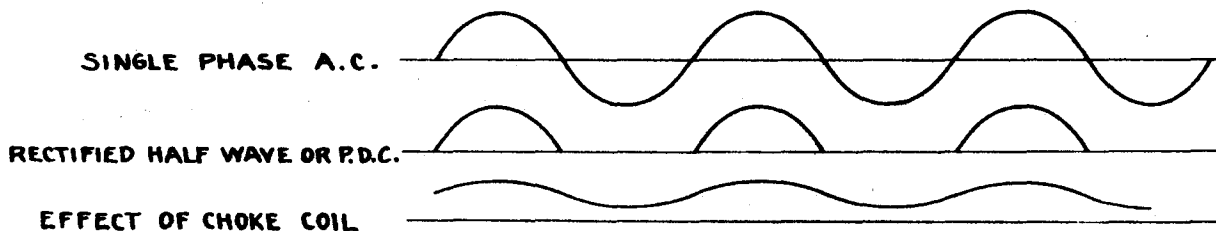
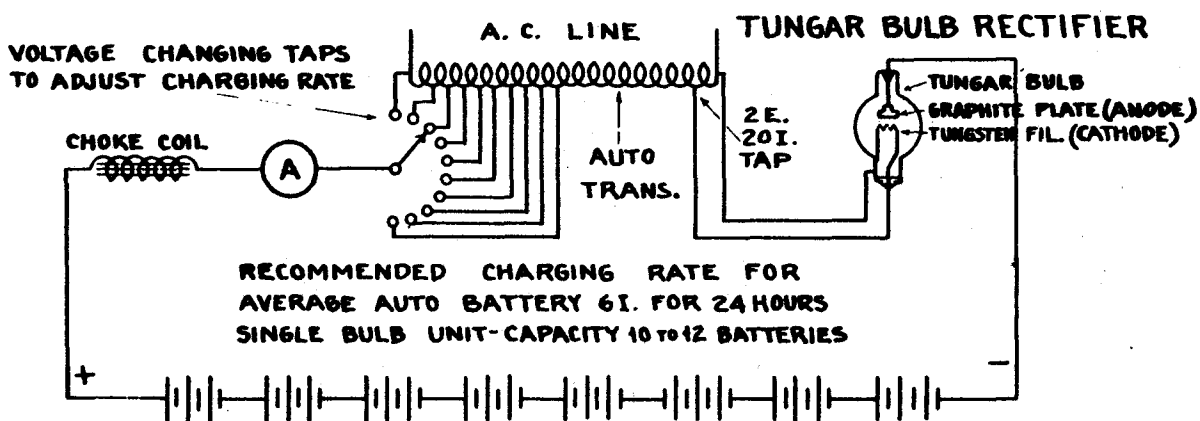
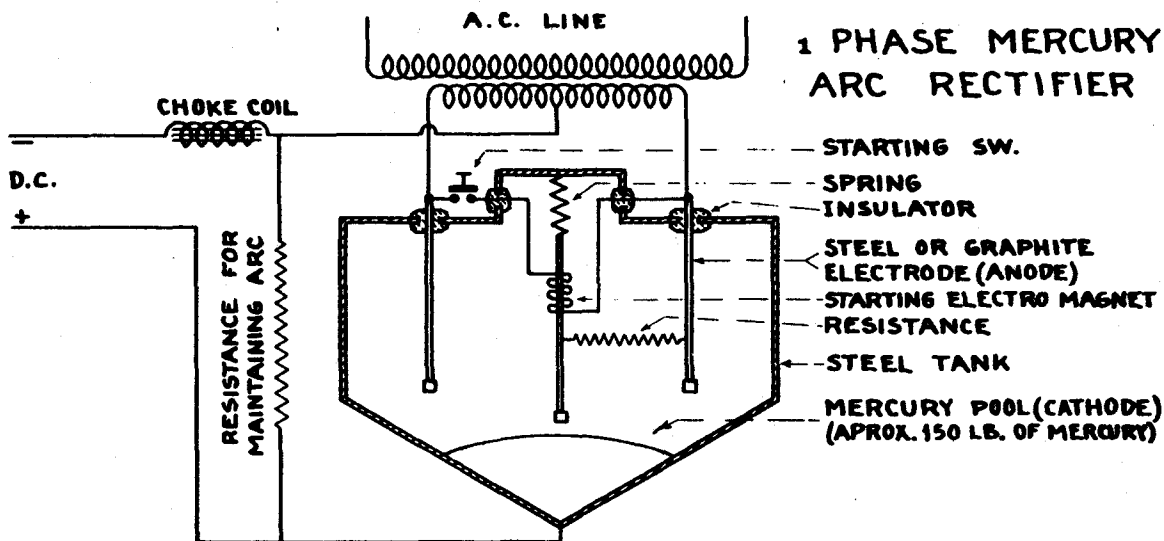
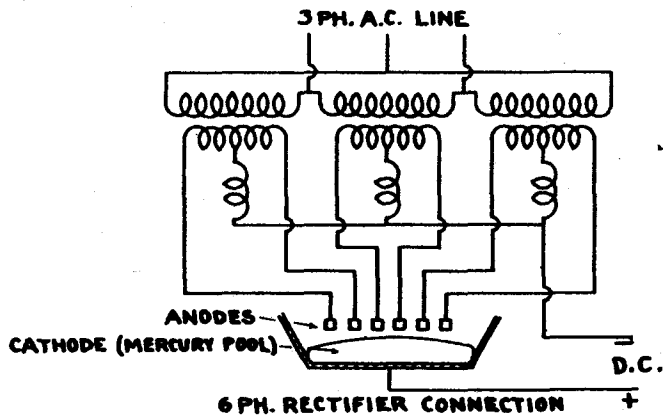
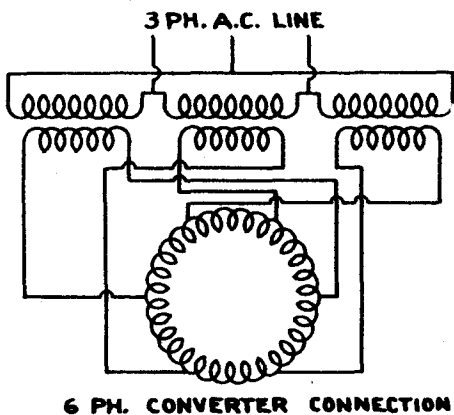

POWER IN THE A.C. CIRCUIT #1.

INDUCTIVE CIRCUIT

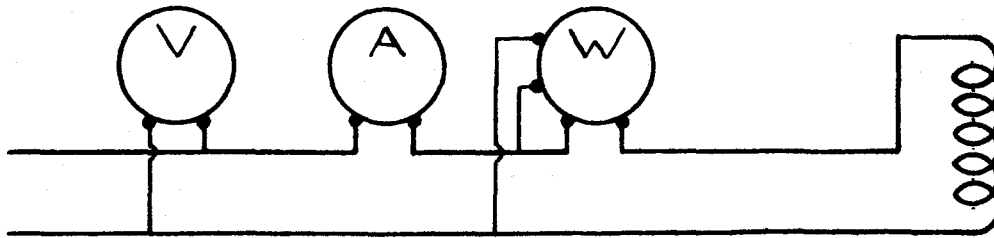

V.A. = $E \times I = \underline{\quad} \times \underline{\quad} = \underline{\quad}$ V.A.

W = W.M. reading ----- = W.

Energy I = $\frac{W}{E} = \underline{\quad} = \underline{\quad}$ I.

P.F. = $\frac{W}{V.A.} = \underline{\quad} = .\underline{\quad} = \underline{\quad} \%$.

CAPACITIVE CIRCUIT

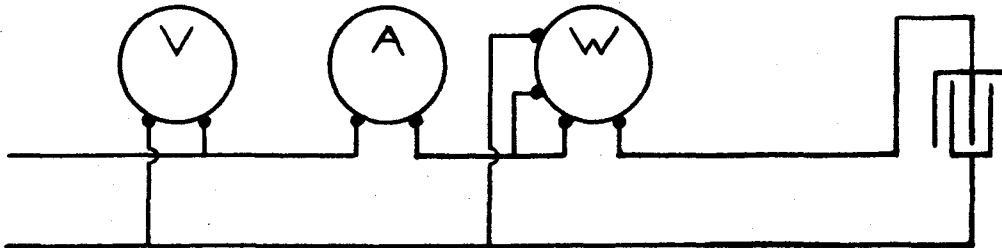

V.A. = $E \times I = \underline{\quad} \times \underline{\quad} = \underline{\quad}$ V.A.

W = W.M. reading ----- = W.

Energy I = $\frac{W}{E} = \underline{\quad} = \underline{\quad}$ I.

P.F. = $\frac{W}{V.A.} = \underline{\quad} = .\underline{\quad} = \underline{\quad} \%$.

INDUCTANCE-CAPACITIVE CIRCUIT

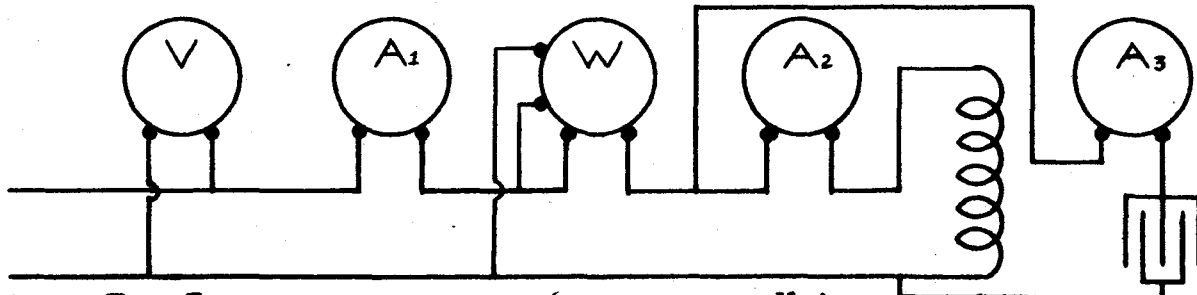

V.A. = $E \times I = \underline{\quad} \times \underline{\quad} = \underline{\quad}$ V.A.

W = W.M. reading ----- = W.

P.F. = $\frac{W}{V.A.} = \underline{\quad} = .\underline{\quad} = \underline{\quad} \%$.

POWER IN THE A.C. CIRCUIT #2.

FULLY LOADED INDUCTION MOTOR WITHOUT P.F. CORRECTION

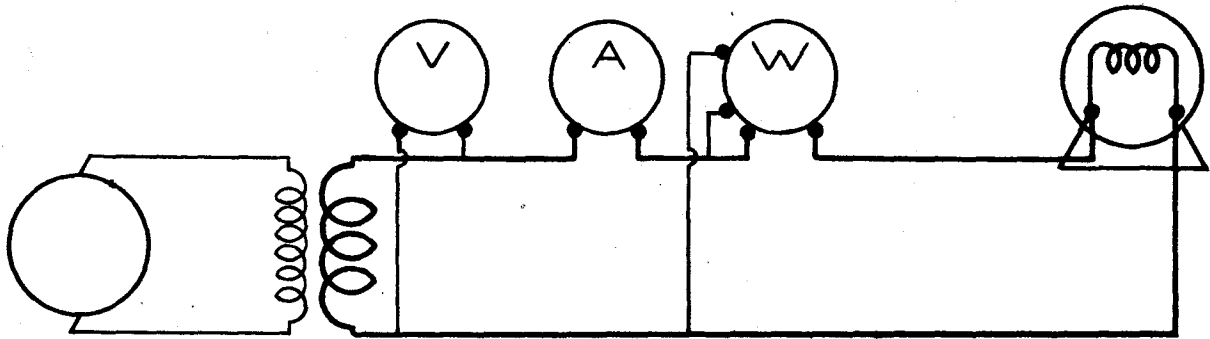

V.A. = $E \times I = \text{_____} \times \text{_____} = \text{_____}$ V.A.

W = W.M. reading _____ = _____ W.

Energy I = $\frac{W}{E} = \text{_____} = \text{_____}$ I.

P.F. = $\frac{W}{V.A.} = \text{_____} = \text{_____} = \text{_____}$ %.

FULLY LOADED INDUCTION MOTOR WITH P.F. CORRECTION.

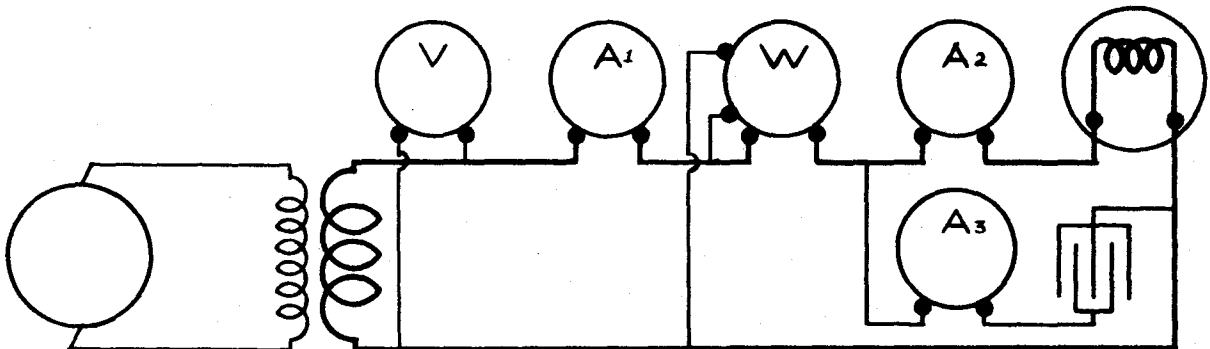

V.A. = $E \times I = \text{_____} \times \text{_____} = \text{_____}$ V.A.

W = W.M. reading _____ = _____ W.

P.F. = $\frac{W}{V.A.} = \text{_____} = \text{_____} = \text{_____}$ %.

Condensers are connected in parallel with inductive apparatus to absorb magnetizing current rather than permit it to return periodically to the generator; and thus improve the P.F. of the circuit.

Disadvantages of low power factor.

1. Greater cost of power due to P.F. penalties imposed on power bill.
2. Larger generators, transformers, transmission lines and apparatus will be required to carry a given K.W. load.
3. Increased line wattage loss and line voltage drop.
4. Voltage regulation is poor on circuits of low power factor.

Causes of low power factor.

1. Under loaded induction motors. 2. Induction furnaces. 3. Electric welders, or in general any inductive apparatus requiring magnetizing current for its operation.

Methods of correcting low power factor.

1. Fully load, or slightly overload induction motors.
2. Static condensers. 3. Synchronous motors.

Condensers used for P.F. correction are rated in K.V.A.

1800 R.P.M.				1200 R.P.M.				900 R.P.M.				720 R.P.M.				600 R.P.M.			
MOTOR		CAPACITOR Kv-A. FOR DESIRED POWER FACTOR		MOTOR		CAPACITOR Kv-A. FOR DESIRED POWER FACTOR		MOTOR		CAPACITOR Kv-A. FOR DESIRED POWER FACTOR		MOTOR		CAPACITOR Kv-A. FOR DESIRED POWER FACTOR		MOTOR		CAPACITOR Kv-A. FOR DESIRED POWER FACTOR	
H.P.	VOLTS	.95	.90	H.P.	VOLTS	.95	.90	H.P.	VOLTS	.95	.90	H.P.	VOLTS	.95	.90	H.P.	VOLTS	.95	.90
1/2	LOW	1/2	1/2	1/2	LOW	1/2	1/2	1/2-3/4	LOW	1	1	5	LOW	2	2	5	LOW	4	3
3/4	LOW	1/2	1/2	3/4	LOW	1/2	1/2	1	LOW	1	1	7 1/2	LOW	4	4	7 1/2	LOW	5	4
1	LOW	1/2	1/2	1	LOW	1/2	1/2	1 1/2	LOW	1 1/2	1	10	LOW	4	3	10	LOW	5	5
1 1/2	LOW	3/4	1/2	1 1/2	LOW	3/4	3/4	2	LOW	1 1/2	1 1/2	15	LOW	5	4	15	LOW	7 1/2	5
2	LOW	3/4	1/2	2	LOW	1	3/4	3	LOW	2	1 1/2	20	LOW	7 1/2	5	20	LOW	10	7 1/2
3	LOW	1	3/4	3	LOW	1 1/2	1	5	LOW	3	2	25	LOW	10	5	25	LOW	10	7 1/2
5	LOW	1 1/2	1	5	LOW	2	1 1/2	7 1/2	LOW	3	3	30	LOW	10	5	25	2200	20	15
7 1/2	LOW	2	1 1/2	7 1/2	LOW	3	1 1/2	10	LOW	4	3	30	2200	10	7 1/2	30	LOW	10	7 1/2
10	LOW	2	1 1/2	10	LOW	3	2	20	LOW	5	5	40	LOW	15	10	30	2200	20	15
15	LOW	3	2	15	LOW	4	3	20	2200	10	7 1/2	40	2200	15	10	40	LOW	15	10
20	LOW	4	2	20	LOW	5	4	25	LOW	10	7 1/2	50	LOW	15	10	40	2200	20	15
25	LOW	4	3	25	LOW	7 1/2	5	25	2200	10	7 1/2	50	2200	15	10	50	LOW	20	15
25	2200	4	3	25	2200	7 1/2	5	30	LOW	10	7 1/2	60	LOW	20	15	50	2200	20	15
30	LOW	5	3	30	LOW	7 1/2	5	30	2200	10	7 1/2	60	2200	20	15	60	LOW	20	15
30	2200	7 1/2	4	30	2200	7 1/2	5	40	LOW	10	7 1/2	75	LOW	20	15	60	2200	25	20
40	LOW	7 1/2	4	40	LOW	10	7 1/2	40	2200	10	7 1/2	75	2200	25	20	75	LOW	25	20
40	2200	7 1/2	4	40	2200	10	7 1/2	50	LOW	15	10	100	LOW	25	20	75	2200	40	30
50	LOW	7 1/2	5	50	LOW	10	7 1/2	50	2200	15	10	100	2200	30	20	100	LOW	20	15
50	2200	7 1/2	5	50	2200	10	7 1/2	60	LOW	15	10	125	LOW	30	20	100	2200	25	20
60	LOW	7 1/2	5	60	LOW	10	7 1/2	60	2200	15	10	125	2200	30	20	125	LOW	30	20
60	2200	10	7 1/2	60	2200	10	7 1/2	75	LOW	15	10	150	LOW	35	25	125	2200	35	30
75	LOW	10	7 1/2	75	LOW	10	7 1/2	75	2200	15	10	150	2200	40	35	150	LOW	50	40
75	2200	10	7 1/2	75	2200	10	7 1/2	100	LOW	20	10	200	LOW	35	20	200	LOW	50	35
								100	2200	20	10	200	2200	40	25	200	2200	50	40
								125	LOW	25	20					150	2200	50	50
								125	2200	25	20								
								150	LOW	25	20								
								150	2200	30	20								
								200	LOW	30	20								
								200	2200	35	20								
								15	LOW	5	4								

COYNE.

THE TABLE ABOVE GIVES THE NEAREST STANDARD CAPACITOR Kv-A. RATINGS TO CORRECT POWER FACTOR OF SQUIRREL-CAGE INDUCTION MOTORS TO .95 OR .90. ALTHOUGH THE MAGNETIZING CURRENT REQUIREMENT OF THE INDUCTION MOTOR VARIES SOME WHAT FROM NO LOAD TO FULL LOAD, IF THE MOTOR IS CORRECTED TO THE DESIRED POWER FACTOR AT 1/2 LOAD (VALUES IN THE TABLE ABOVE) IT WILL BE CORRECTED APPROXIMATELY TO THIS POWER FACTOR AT ALL LOADS. ACTUALLY THE POWER FACTOR WILL BE SOME WHAT HIGHER AT NO LOAD AND SLIGHTLY LOWER AT FULLLOAD. NOTE:-LOW VOLTS MEANS 220-440-550.

JOB No. 9 - TESTING THE FULL LOAD EFFICIENCY AND
POWER FACTOR OF A 3PH. INDUCTION MOTOR

To this test a D.C. generator is used to impose full-load on the motor. The output of motor in watts is determined by measuring the output of a D.C. generator and adding to this the I^2R losses of the generator and also its friction and windage losses. The resistance of the different circuits must be known. These values are given on the job. In the following outline, the armature resistance will be designated as R_1 ; the shunt field resistance R_2 ; and the series field resistance as R_3 .

PART A -- Take meter readings and mark in proper places.

DIRECT CURRENT

ALTERNATING CURRENT

E = _____

E = _____

I = _____

I = _____

W = E X I = _____ = _____ Watts
LOSSES

W = $W_1 \pm W_2$ = _____ + _____ = _____ Watts

Watts lost in armature $I^2R_1 =$ _____ = _____ Watts

Watts lost in shunt field $I^2R_2 =$ _____ = _____ Watts

Watts lost in series field $I^2R_3 =$ _____ = _____ Watts

Watts lost in friction & windage = _____ = _____ Watts

Total Watts lost = _____

Total Watts output of motor = Watts output of generator + Generator losses
= _____ + _____ = _____ Watts

Eff. of motor = $\frac{W \text{ Output}}{W \text{ Input}} = \frac{\text{Output}}{W_1 \pm W_2} =$ _____ = _____

Power Factor of 3 ph. motor = $\frac{\text{True W. Input}}{\text{App. W. Input}} = \frac{W_1 \pm W_2}{E \times I \times 1.73} =$ $\frac{W_1}{E \times I} + \frac{W_2}{I \times 1.73}$

= $\frac{\text{Total W}}{\text{Total V.A.}} =$ _____ = _____ %

PART B -- Connect K.V.A condenser to motor: Take meter readings and mark as above.

DIRECT CURRENT

ALTERNATING CURRENT

E = _____

E = _____

I = _____

I = _____

W = E X I = _____ = _____ = Watts
LOSSES

W = $W_1 \pm W_2$ = _____ = _____ Watts

Watts lost in armature $I^2R_1 =$ _____ = _____ Watts

Watts lost in shunt field $I^2R_2 =$ _____ = _____ Watts

Watts lost in series field $I^2R_3 =$ _____ = _____ Watts

Watts lost in friction & windage = _____ = _____ Watts

Total Watts lost = _____

Total Watts output of motor = Watts output of generator + Generator losses
= _____ + _____ = _____ Watts

Eff. of motor = $\frac{W. \text{ Output}}{W. \text{ Input}} = \frac{\text{Output}}{W_1 \pm W_2} =$ _____ %

Power Factor of 3 Ph. motor = $\frac{\text{True W Input}}{\text{App. W Input}} = \frac{W_1 \pm W_2}{E \times I \times 1.73} =$ $\frac{W_1}{E \times I} + \frac{W_2}{I \times 1.73}$

= $\frac{\text{Total W}}{\text{Total V.A.}} =$ _____ = _____ %

PARALLELING THREE PHASE TRANSFORMERS

Instructions for A:

POLARIZING

1. Connect primary of one phase of the transformer to a suitable A.C. supply - rated voltage or less - as shown in Section A.
2. Measure both primary and secondary voltages.
3. Connect voltmeter as shown in 1, 2, and 3, Section A, and note whether instrument indicates the sum or the difference of the primary and secondary voltages. If sum is given, additive polarity is indicated; if difference, subtractive polarity.

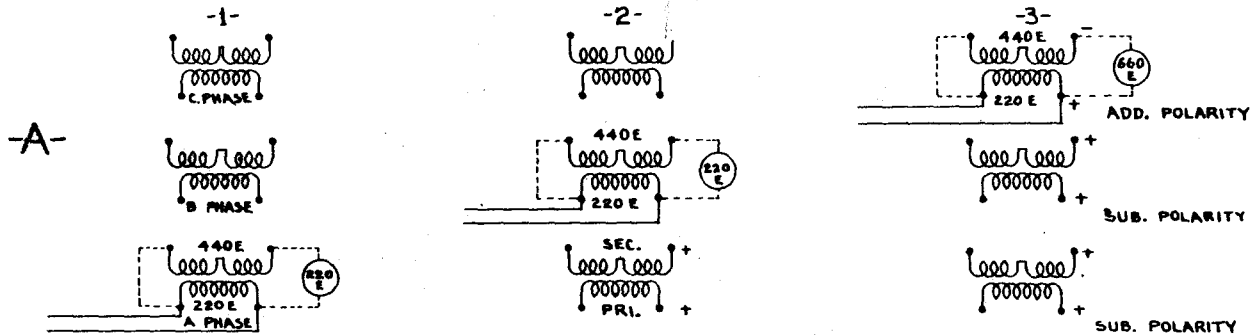

Instructions for B:

PHASING OUT

1. Assume three ends of the three primary phases to be "finishes" and join them together. Connect the three assumed "starts" to the line. (1-B)
2. Take a voltmeter reading on each primary phase.
3. If the readings are not equal, reverse the leads of one phase and test again. If still unequal, replace the leads and reverse the next phase. Repeat until equal readings are obtained, and then mark the ends connected together "F" and those attached to the line "S". The starts and finishes of the secondary winding may be determined from the transformer polarity as indicated in Diagram 2-B.

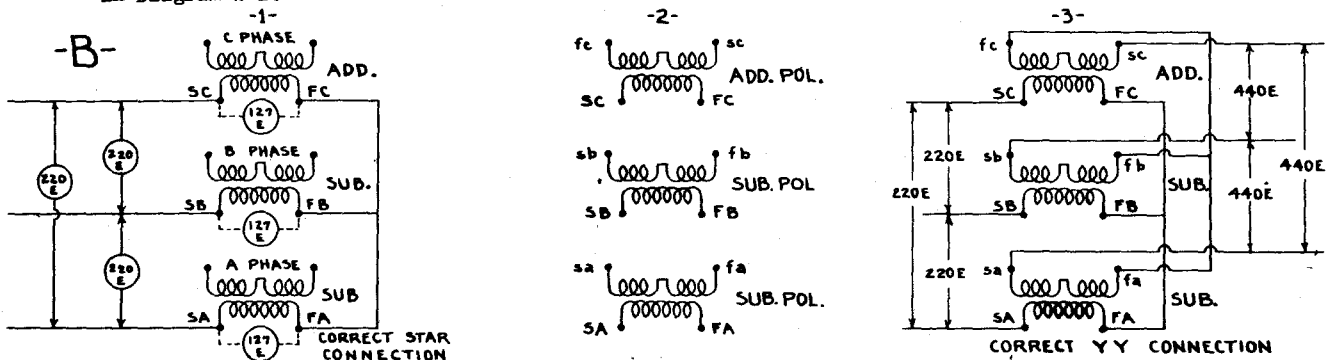

Instructions for C:

PARALLELING

1. After the transformers have been polarized, phased out, and the leads properly marked, they may be paralleled. Identification of each line will be necessary before the primary windings are connected, and a symmetrical arrangement of the transformer leads is essential.
2. After the ends of each line have been found and marked, connect the primary leads "S0" and "SA₁" to the same line; "SB" and "SB₁" to the next wire; and "SC" and "SC₁" to the remaining line. Connect the primary finishes together.
3. The secondary connections are made by joining the secondary finishes together and then connecting corresponding ends of the different phases together, "sa" to "sa₁", "sb" to "sb₁", and "sc" to "sc₁". To prevent an incorrect connection, connect only one secondary wire, say from "sa" to "sa₁", and check the voltage between the remaining secondary terminals. Connect together only those terminals between which there is no difference in voltage.

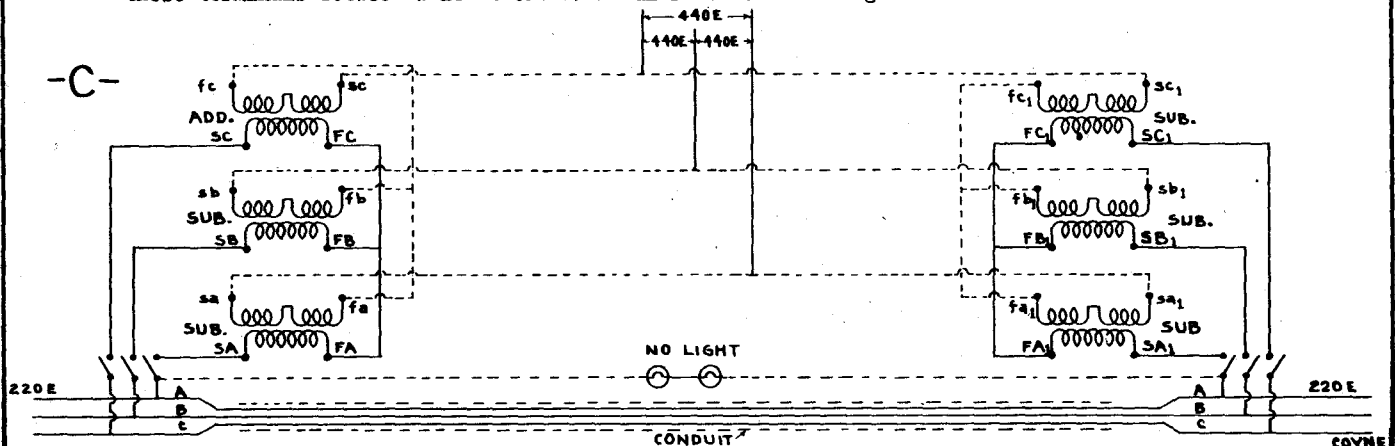

Job No. 13

TRANSFORMER

CONNECTIONS

This job is used to illustrate the different connections that may be made with single-phase transformers, and also to demonstrate the relationship that exists between the line and phase voltages for the various three-phase connections. Take the readings indicated below the diagram and enter them in the spaces provided. Make the delta connection first, then add the fourth wire and read from line to N.

Section 2 shows a delta-star connection with a four-wire secondary. Connect and read as indicated in Section 1. Note that on all connections, line voltages are obtained between L₁, L₂, L₃, and phase voltages from H₁ to H₂ or X₁ to X₂. In the four-wire secondary used here, phase voltages are also obtainable from any secondary line to the neutral wire. The neutral is usually grounded.

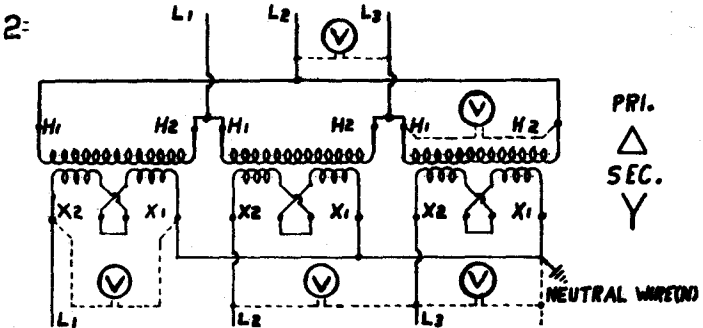
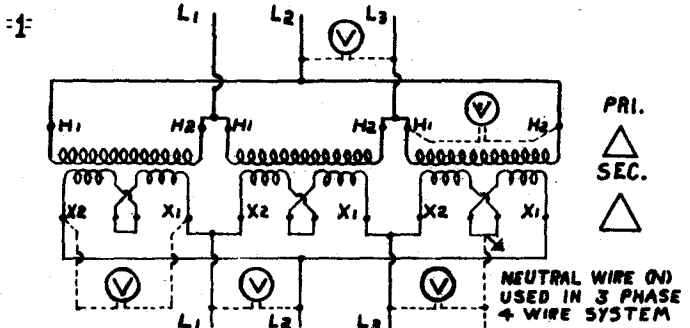

PRI. LINE E _____
 PRI. PHASE E _____
 RATIO _____
 SEC. PHASE E _____
 SEC. LINE E _____
 ADD NEUTRAL (N) & CHECK VOLTAGE
 L₁ to N L₂ to N L₃ to N

E BETWEEN L₁ to N, & L₃ to N = LINE E X 0.5
 E BETWEEN L₂ & N = LINE E X 0.866

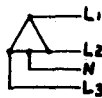

PRI. LINE E _____
 PRI. PHASE E _____
 RATIO _____
 SEC. PHASE E _____
 SEC. LINE E _____
 ADD NEUTRAL (N) & CHECK VOLTAGE
 L₁ to N L₂ to N L₃ to N

E BETWEEN L₁, L₂ & L₃ to N = LINE E X 0.58

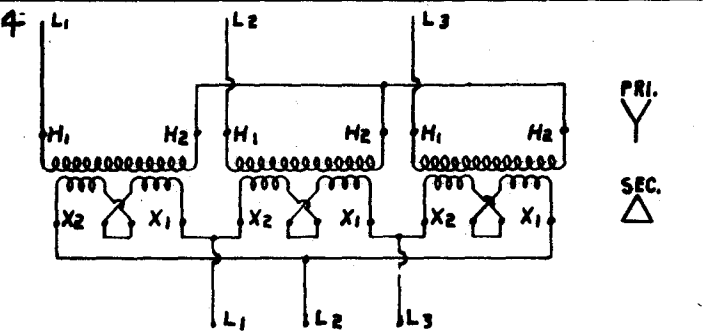
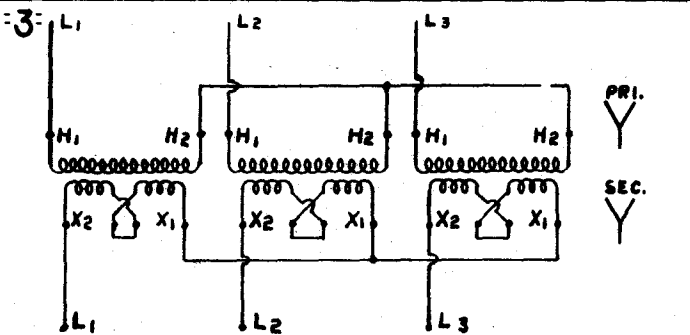

PRI. LINE E _____
 PRI. PHASE E _____
 RATIO _____
 SEC. PHASE E _____
 SEC. LINE E _____

PRI. LINE E _____
 PRI. PHASE E _____
 RATIO _____
 SEC. PHASE E _____
 SEC. LINE E _____

In the above connection, which is the star-star arrangement, take all readings required, mark the starts and finishes on both primary and secondary. Also indicate that polarity each transformer has; that is, whether it is additive or subtractive. What voltage is obtained from the star point to the line wire on the primary - on the secondary? Does this voltage equal the phase voltage?

Repeat all tests enumerated in Section 5. How do the line and phase voltages compare on the primary; on the secondary? If one transformer failed, could a three-phase supply be maintained by the connection used in Section 1; in Section 2; in Section 5; in Section 4? From the answers to the above questions, derive the advantages of the delta connection as compared with the star.

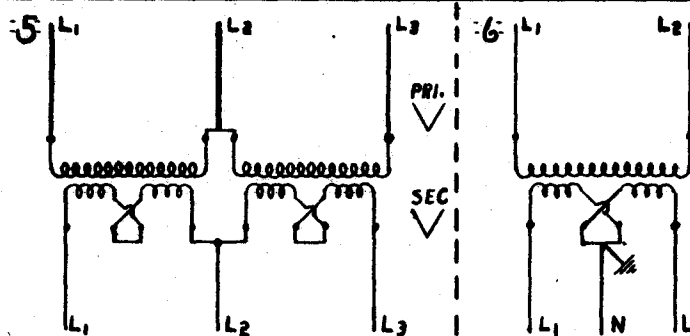

CONNECTED OPEN-DELTA
 PRI. LINE E _____
 PRI. PHASE E _____
 RATIO _____
 SEC. PHASE E _____
 SEC. LINE E _____

Single Phase 3 Wire System
 Pri. line E _____
 Ratio _____
 Sec. line E _____
 L₁ to N _____
 L₂ to N _____

Note that this connection uses two single-phase transformers and that a true three-phase transformation is obtained. Particularly note the voltage readings between secondary lines. Explain this.

Compare these readings with those obtained on open-delta and explain why they differ.

VOLTAGE AND CURRENT FORMULAS FOR STAR AND DELTA CONNECTIONS.

STAR CONNECTED
 LINE I = PHASE I
 LINE E = PHASE E X 1.73
 PHASE E = LINE E X 0.58

DELTA CONNECTED
 LINE E = PHASE E
 LINE I = PHASE I X 1.73
 PHASE I = LINE I X 0.58

THESE FORMULAS ARE USED TO CHECK THE ACCURACY OF THE METER READINGS

Some discrepancy between the meter readings and the formulated values must be expected, since the formulas are based on ideal conditions rarely obtained in practice. Moreover, there is always the possibility of meter error to be considered. However, considerable departure from the theoretically correct values indicated by the formulas should be investigated, as they point either to serious meter defects or to improper connections.

When connecting the primary windings of single-phase transformers to the line, either end of any given primary winding may be regarded as a start, the other end then becoming a finish. After the primaries are connected, however, certain secondary ends are starts, the other ends being finishes, and these cannot then be interchanged since the secondary start and finish relationship is automatically established when the primary windings are connected.

TESLA COIL

6" COPPER BALLS

THE SECONDARY CONSISTS OF 1000 TURNS OF NO. 24 D.C.C. WIRE, SPACE WOUND ON A FIBRE TUBE 1'-2" x 4'-6". THE ENTIRE COIL SHOULD BE GIVEN A COAT OF SHELLAC OR COLLODION.

THE PRIMARY CONSISTS OF 10 TURNS OF 1/2" COPPER TUBING, SPACE WOUND ON A WOODEN DRUM 2'-8" x 12". THE PRIMARY IS MOUNTED ON 7" PYREX INSULATORS.

A FLEXIBLE LEAD AND CLIP IS USED TO VARY THE NUMBER OF PRI. TURNS.

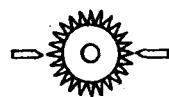

A ROTARY SPARK GAP WILL GREATLY IMPROVE THE OPERATION.

1 K-VA. TRANSFORMER.

110E. A.C. LINE

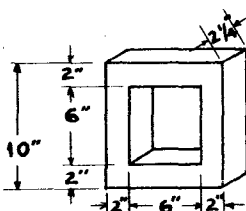
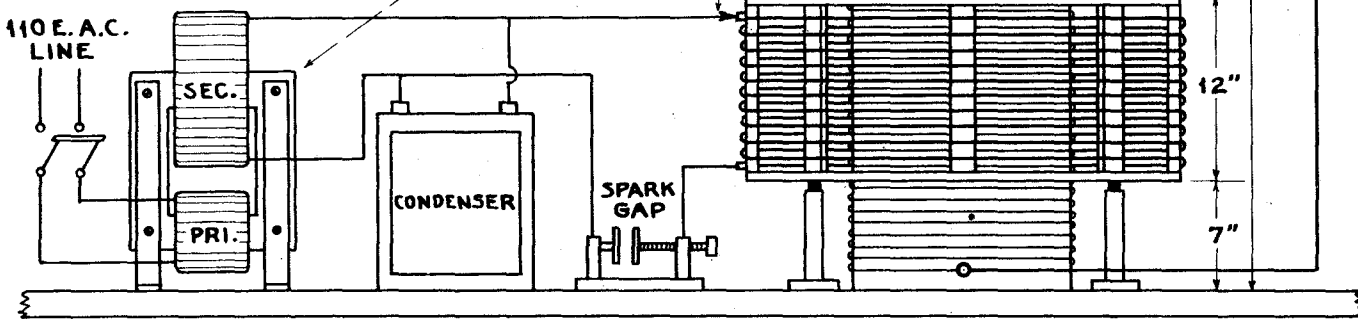

TRANSFORMER DETAILS.
CORE - 40 LBS. OF IRON.
PRI. - 130 TURN #14 S.C.E. WIRE. 2 LBS.
SEC. - 29,500 T. #34 S.C.E. WIRE. 5 LBS.
PRI. - 110E. SEC. - 25,000E.

THE 3 CELLS ARE CONNECTED IN PARALLEL.

THE CONDENSER CONSISTS OF 48 SHEETS .005" BRASS SEPARATED BY DOUBLE STRENGTH GLASS SHEETS AND ASSEMBLED IN A THREE CELL AUTO BATTERY CASE FILLED WITH TRANSFORMER OIL. DETAILS OF UNIT FOR ONE CELL ARE SHOWN AT THE RIGHT. IMPROVED PERFORMANCE MAY SOMETIMES BE OBTAINED BY INCREASING OR DECREASING THE NUMBER OF PLATES. THE BEST ARRANGEMENT WILL BE FOUND BY TRIAL.

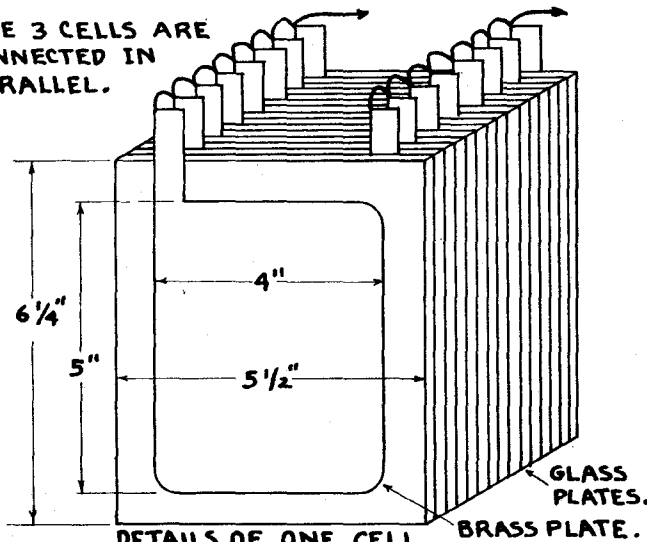

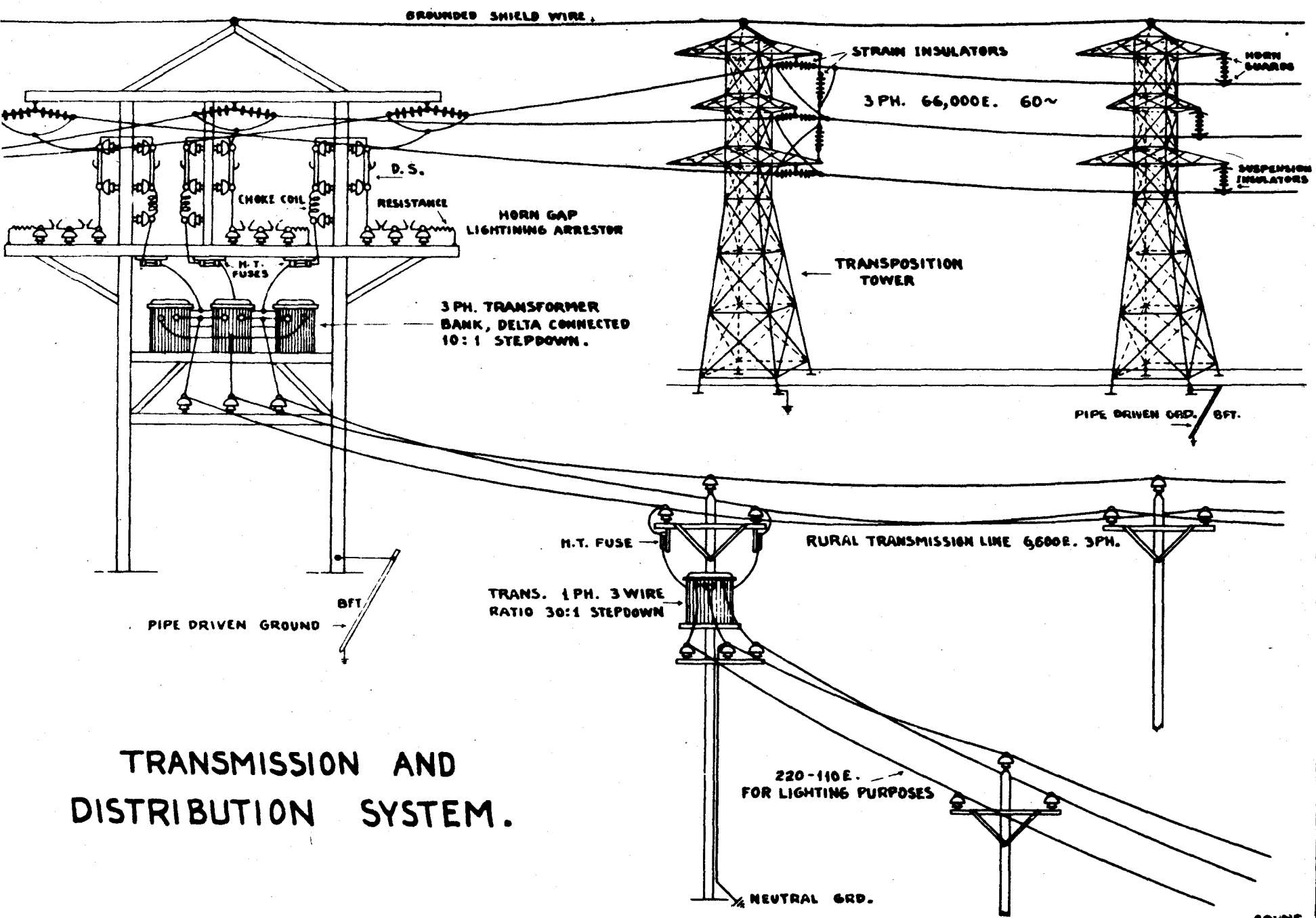

TRANSMISSION AND DISTRIBUTION SYSTEM.

POWER & LIGHTING DISTRIBUTION SYSTEM

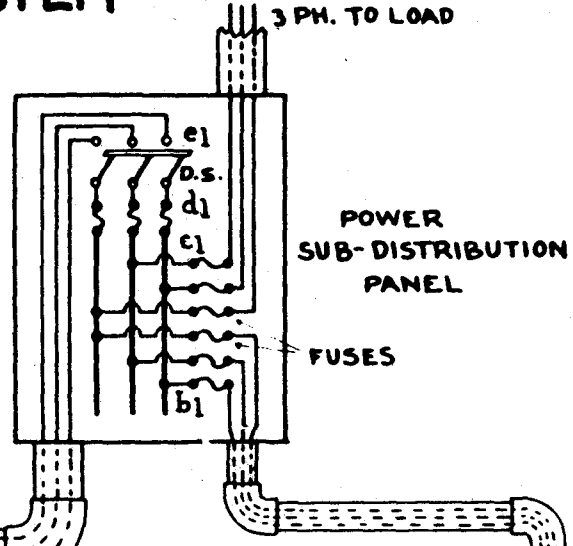
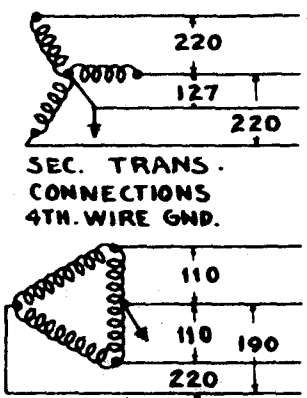
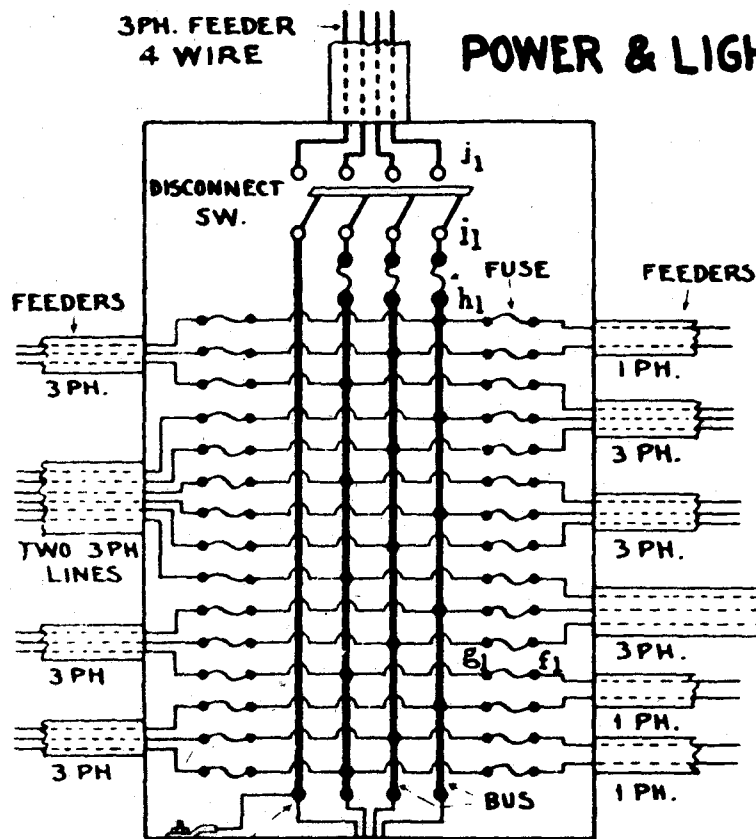

ALL PANELS AND CONDUIT ARE GROUNDED

General Procedure When Testing

With 3 ph. power at a, check forward thru b, c, d, and e. If 3 ph. power is not shown at a, check backward thru b1, c1, d1, e1, f1, g1, h1, i1, and j1.

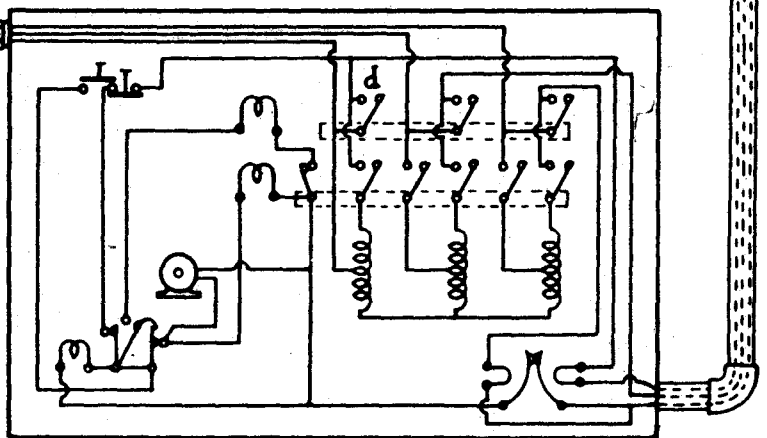
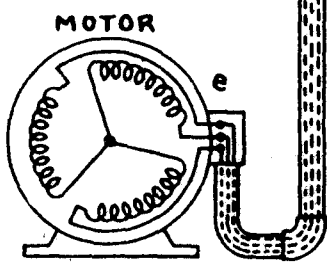
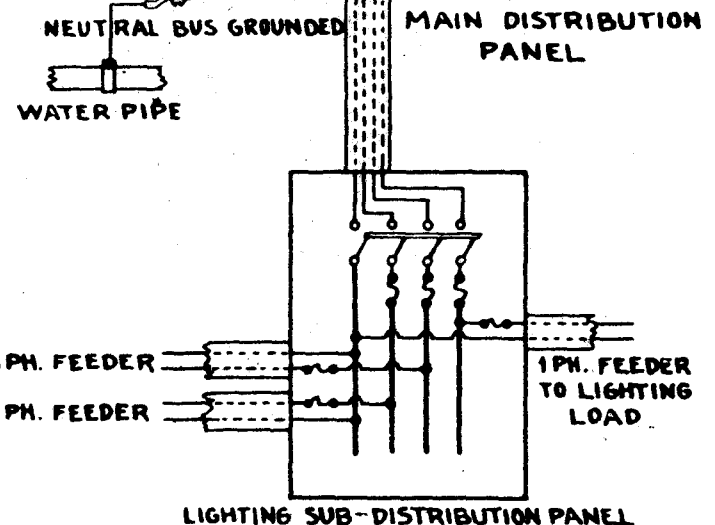
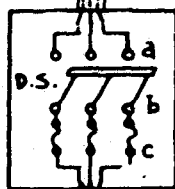

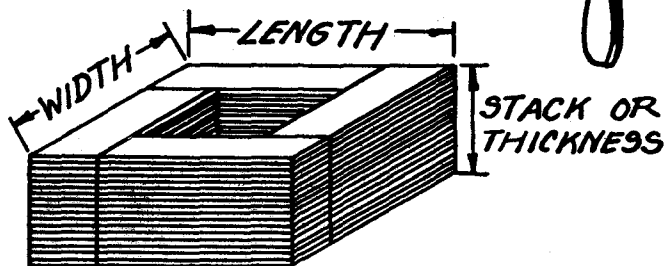
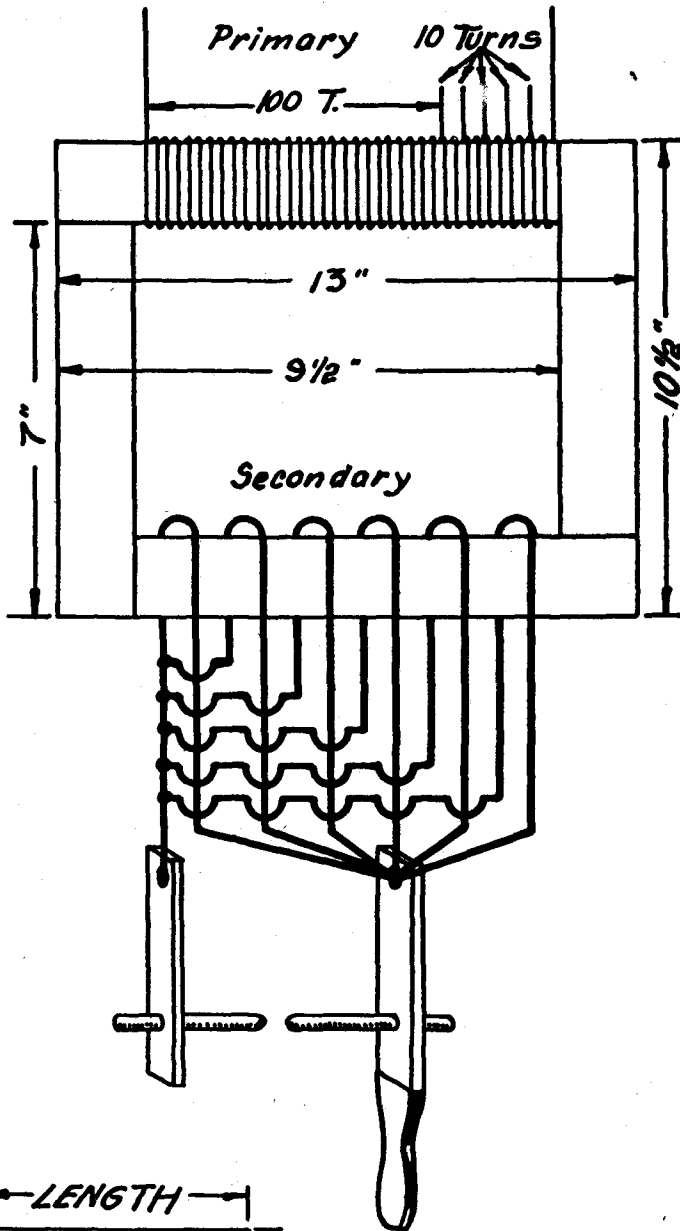
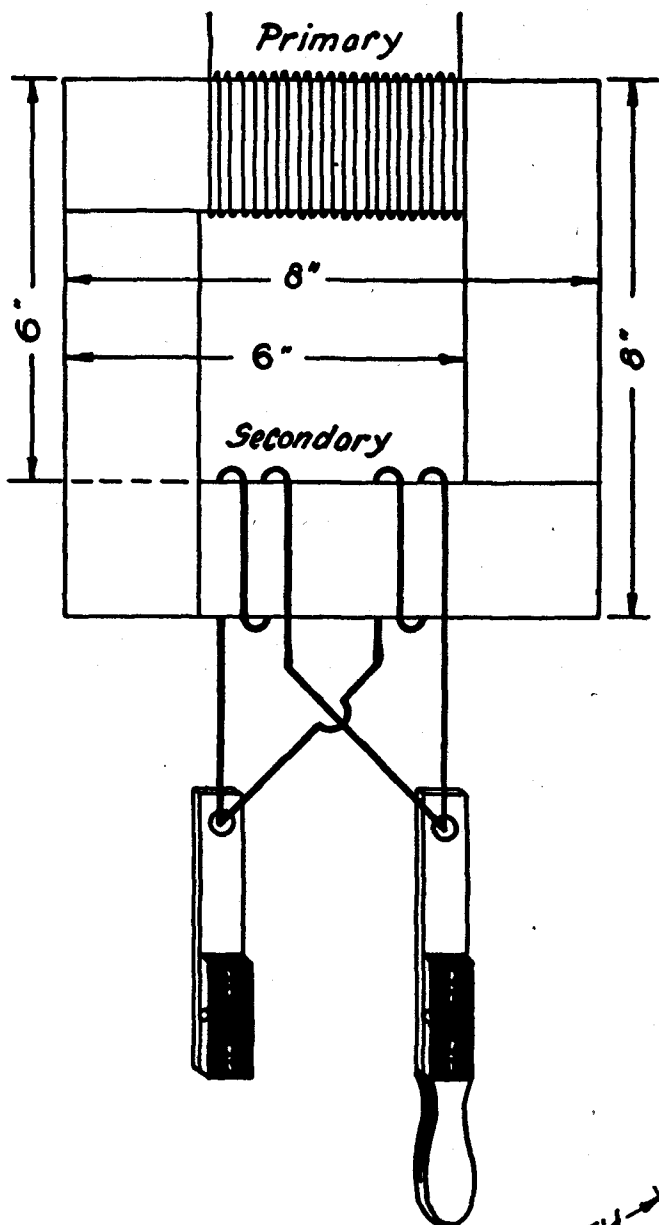

BUTT WELDER

PRIMARY: 220 E. 60~50 I. 126 Turns
7 D.C.C. Wire.

SECONDARY: 4 E. 60~3000 I. 2 Turns
of # 4/0 Cable. 2 Parallel.

CORE: 80 Lbs. of Laminated Iron
or Silicon Steel
Core Strips 2"x6"
Stack 4" High or Thickness
of core.

SPOT WELDER

PRIMARY: 220 E. 60~45 I. 150 Turns
4 D.C.C. Wire.

SECONDARY: 2 1/2 E. 60~2000 to 3000 I
3/4 Turn # 4/0 Cable. 6
Parallel.

CORE: 120 Lbs. Laminated Iron.
Stack 4 1/2" High.

Starting at 100th Turn, on Primary
Winding, Take Taps Every 10 Turns.

HOW THE NEUTRALIZER QUENCHES A FAULT

Fig. 2. Ground-fault currents, isolated-neutral system

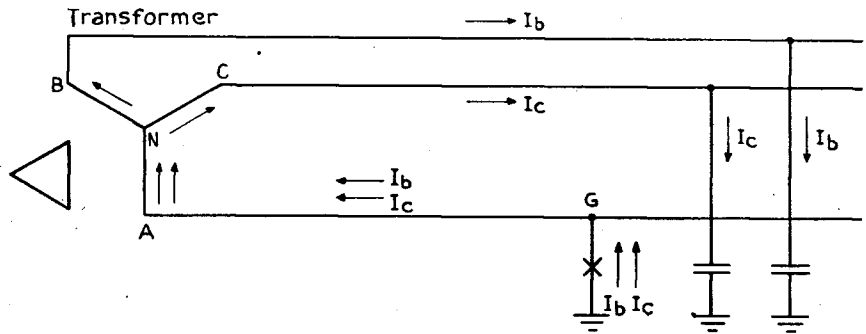

Fig. 3. Ground-fault currents, solidly grounded neutral system

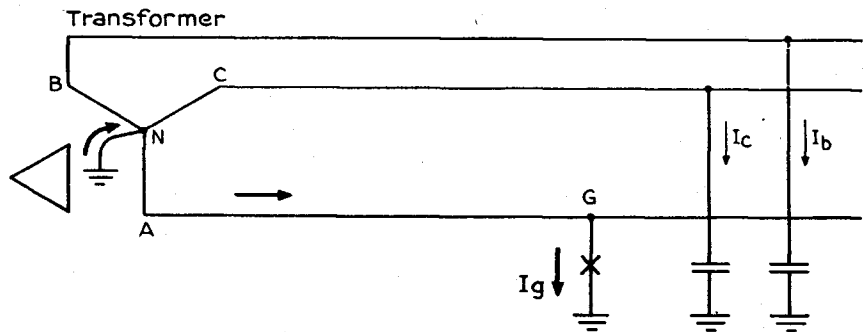
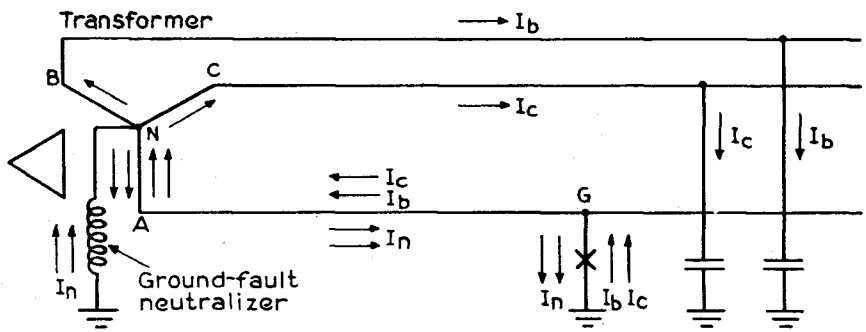

Fig. 4. Ground-fault currents, with neutralizer



● When the System Neutral Is Isolated, the current in a line-to-ground fault consists solely of charging current through the line-to-ground capacitances of the other two line conductors (Fig. 2). However, operating experience shows that such disturbances frequently result in transient over-voltages sufficient to cause a second flashover on one of the unfaulted phases, thus causing a short circuit and an interruption to service. Relaying is difficult because the second fault usually occurs at a point remote from the first—frequently in terminal apparatus—necessitating expensive repairs.

● When the System Neutral Is Solidly Grounded, a line-to-ground fault short-circuits the faulted phase, causing current to flow through the fault, as shown in Fig. 3. This short-circuit current, I_g , is lagging, and is usually so much greater than the charging current of the unfaulted lines (I_b and I_c) that the effect of the latter is negligible. The fault persists until the circuit-breaker is tripped. This means a service interruption.

● When the System Neutral Is Grounded through a Ground-fault Neutralizer, transitory arcs to ground are extinguished without an outage, without even a momentary interruption of service, and without the aid of any moving parts. The line-to-ground fault causes line-to-neutral voltage to be impressed across the neutralizer, which then passes an inductive current, I_n , 180 degrees out of phase and approximately equal in magnitude to the resultant of the system-charging currents from the two unfaulted phases, I_b and I_c (Fig. 4).

These inductive and capacitive currents neutralize each other, and the only remaining current in the fault is due, mainly, to corona, insulator leakage, etc. This current is relatively small, and, as it is in phase with the line-to-neutral voltage, the current and voltage reach a zero value simultaneously, hence, the arc is extinguished without restriking. In this way, flashovers are quenched without removing the faulted line section from service.

Squirrel-Cage Motors

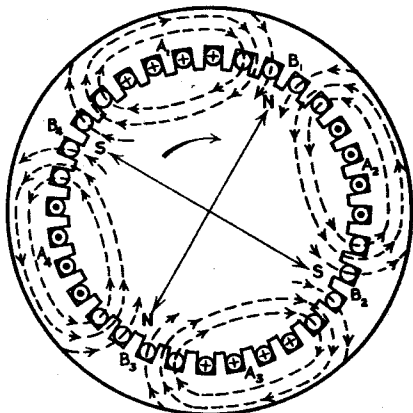

FIG. 4

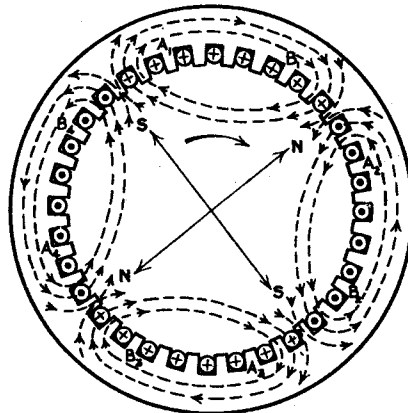

FIG. 5

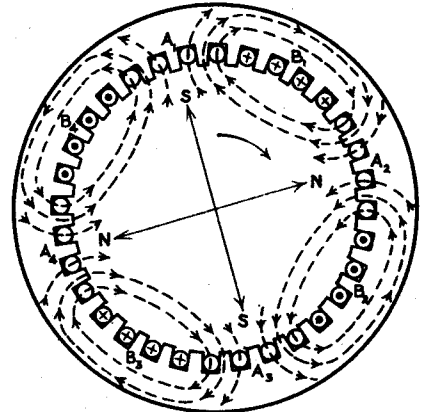

FIG. 6

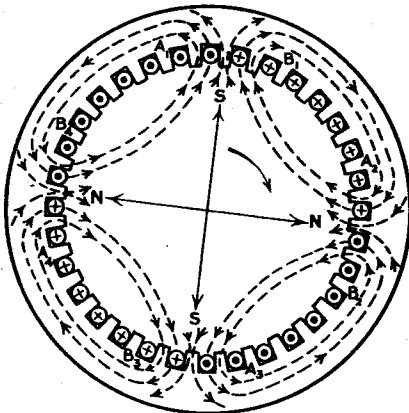

FIG. 7

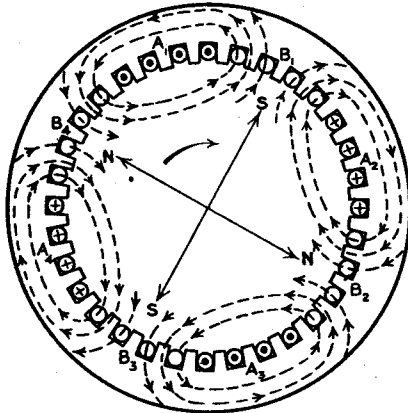

FIG. 8

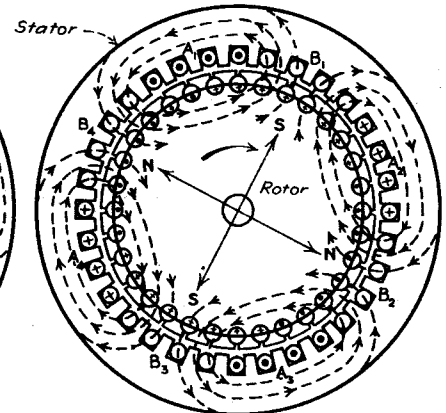

FIG. 9

Figs. 4 to 8—How the magnetic field in an induction-motor stator can be made to rotate when its windings are connected to a 2-phase circuit. Fig. 9—Direction of current generated in a rotor winding shown by dots and crosses on the rotor bars

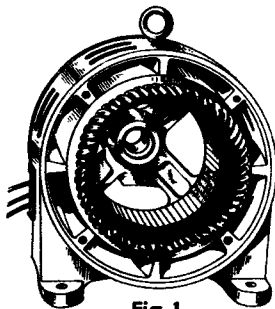

Fig. 1

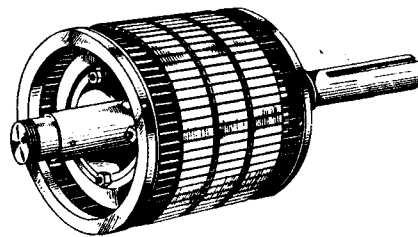

Fig. 2

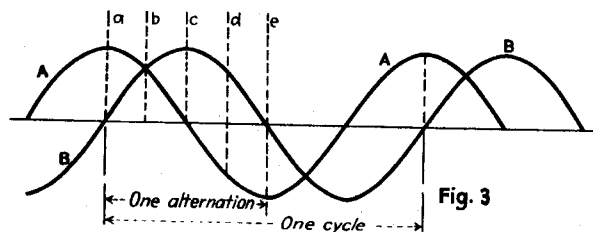

Fig. 3

Fig. 1—Stator of an induction motor. Fig. 2—Squirrel-cage rotor of an induction motor. Fig. 3—Two-phase voltage or current curves

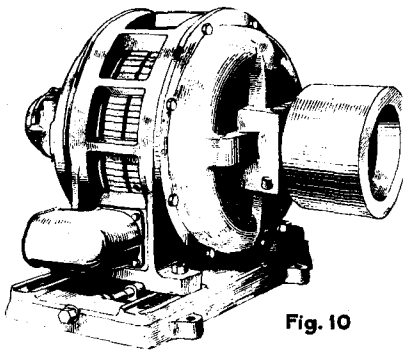

Fig. 10

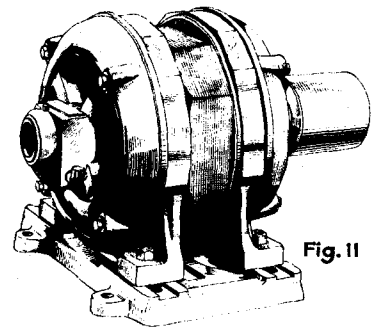

Fig. 11

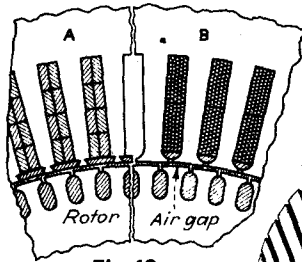

Fig. 12

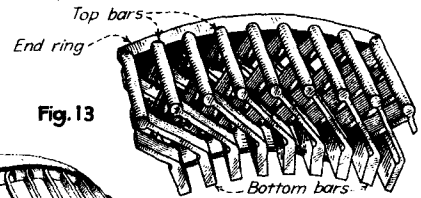

Fig. 13

Fig. 10—Skeleton stator frame. Fig. 11—Riveted stator frame. Fig. 12—A, stator open slots; B, semiclosed slots. Fig. 13—Section of cast, interconnected double-squirrel-cage winding. Fig. 14—Section of simple double-squirrel-cage winding. Fig. 15—Squirrel-cage winding formed from a copper plate. Fig. 16—Joint between rotor bar and end ring

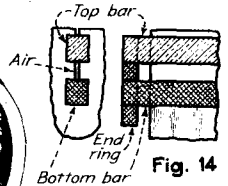

Fig. 14

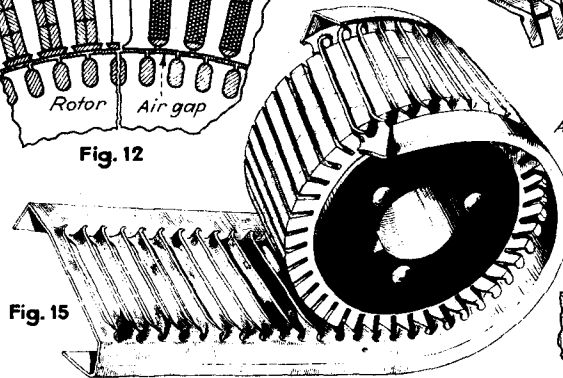

Fig. 15

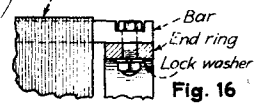

Fig. 16

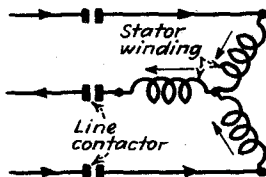

FIG. 1

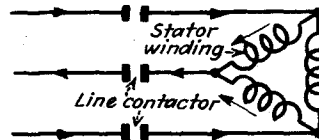

FIG. 2

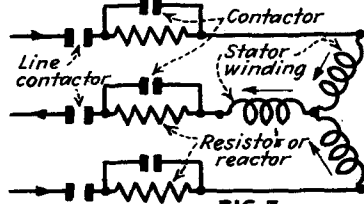

FIG. 3

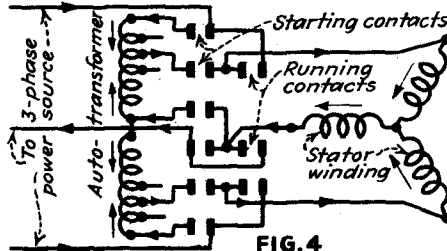

FIG. 4

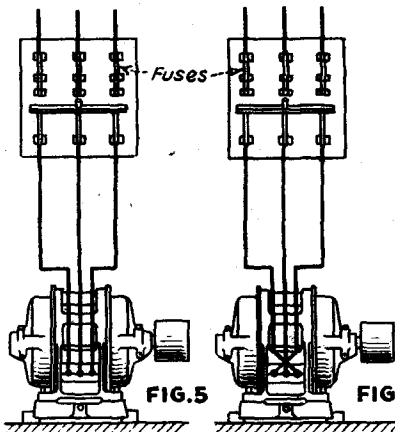

FIG. 5

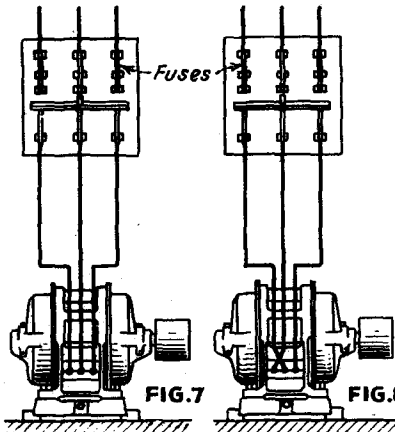

FIG. 6

Fig. 1—Diagram of star-connected stator windings. Fig. 2—Stator windings connected delta. Fig. 3—Connections for starting with resistors or reactors in series with stator windings of a 3-phase motor. Fig. 4—Two auto-transformers connected to start a 3-phase motor. Fig. 5—Connections for one direction of rotation and Fig. 6, opposite direction of rotation of a 3-wire, 2-phase motor. Figs. 7 and 8—Connections for opposite directions of rotation of a 3-phase motor

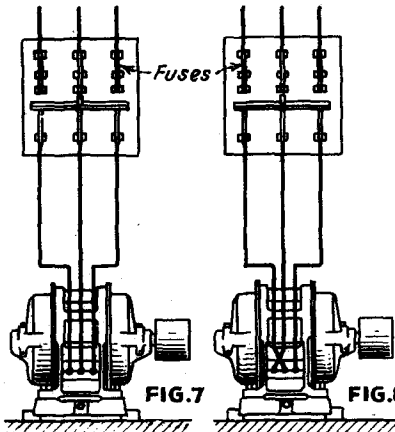

FIG. 7

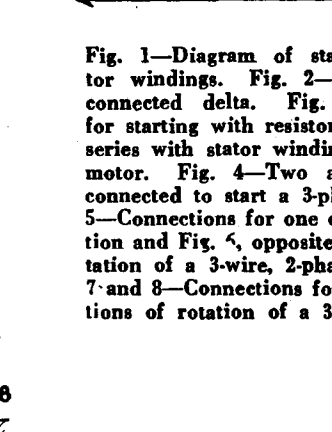
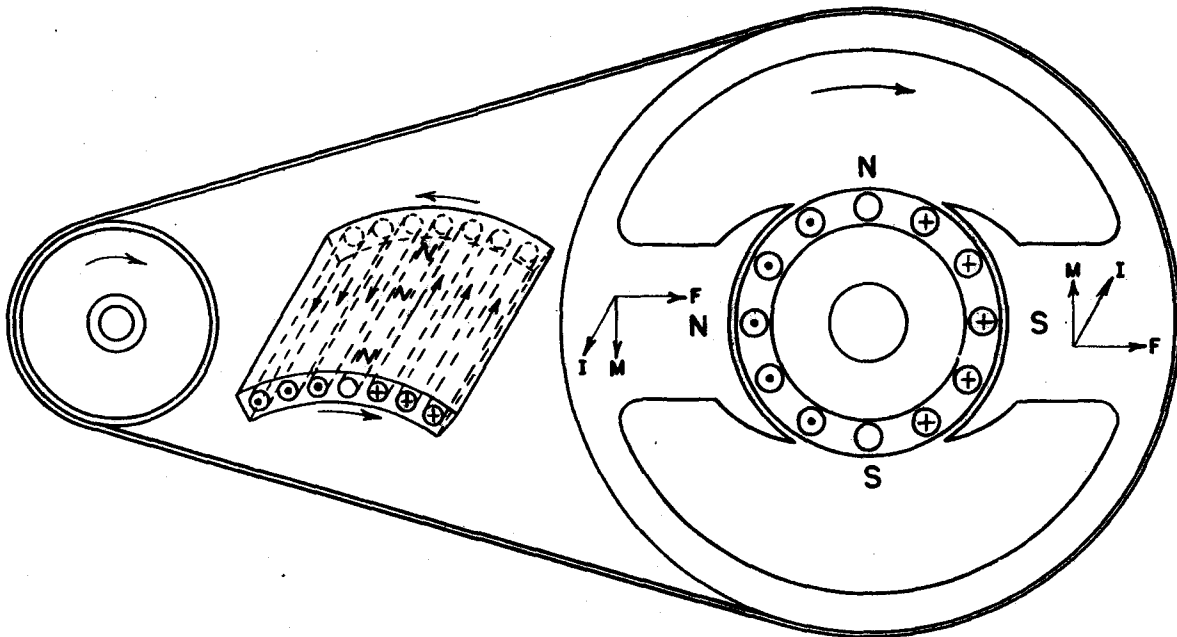

FIG. 8

ROTATING MAGNETIC FIELD.

NOTE: FLEMING'S RULE IS APPLIED TO MOTION OF THE CONDUCTOR.

FLUX MOVING UP IS EQUIVALENT TO CONDUCTOR MOVING DOWN.



If a permanent magnet of the type shown above be rotated about a squirrel cage rotor, the flux of the magnet will cut across the squirrel rotor bars and induce voltage in them. The direction of these voltages at any instant may be determined by Fleming's Right Hand Rule. Application of this rule to the diagram above shows that currents will be flowing toward the observer under the North pole, and away from the observer under the South pole.

Viewed from above, current is circulating counter-clockwise around the rotor thereby establishing a North pole at the top and a South pole at the bottom. As the magnetic field is rotated, the rotor poles move at the same speed and in the same direction and maintain the same relative position; that is, midway between the stator poles.

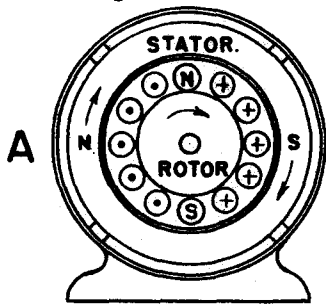

Diagrams A B C D show the relative position of the rotor and stator poles for four different points in one revolution.

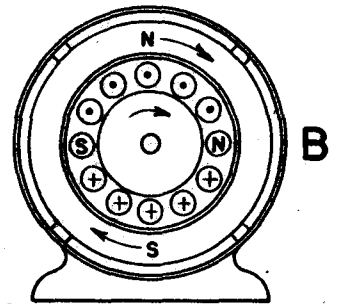

In A there exists at the instant shown the same condition described above. In this case however, the rotating magnetic is produced by a different method.

In B the revolving field has moved through one-quarter revolution. Note the change in current distribution in the rotor bars and the movement of the rotor poles. Diagrams C and D show the condition at later points in the revolution. Reversal of current in rotor bars causes rotor poles to revolve.

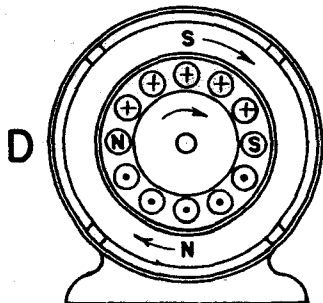

Although the diagrams show the current in the rotor bars changing direction in groups, the rotor bar currents actually reverse one at a time as the stator flux sweeps by. This produces a smooth progression of the poles around the rotor.

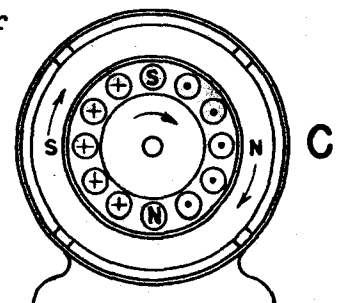

POSITION INDICATORS.

Position indicators are employed to transmit motion by electrical means between points which cannot be readily connected mechanically. In Figure A rotation of the arm on the sender rheostat varies the current through the receiver which is used as a receiver. When properly calibrated, the meter needle motion will be proportional to the motion at the sender. Thus the amount of gasoline in the tank may be indicated on the instrument panel of a car.

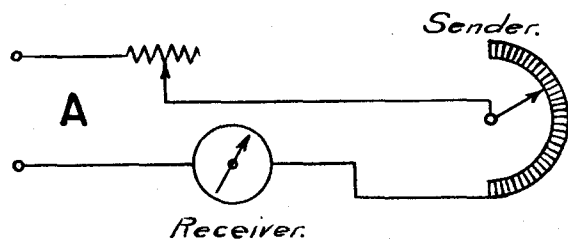

Figure B shows a similar arrangement except that clockwise rotation of the sender increases the voltage applied to the receiver and the deflection is in proportion to it.

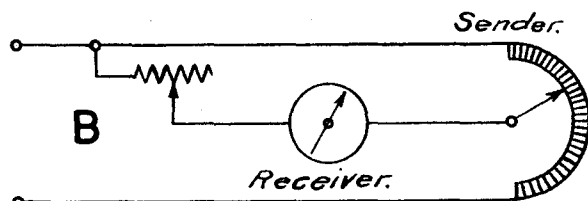
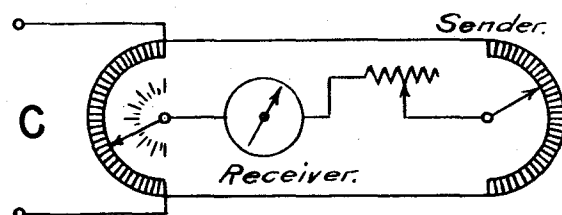
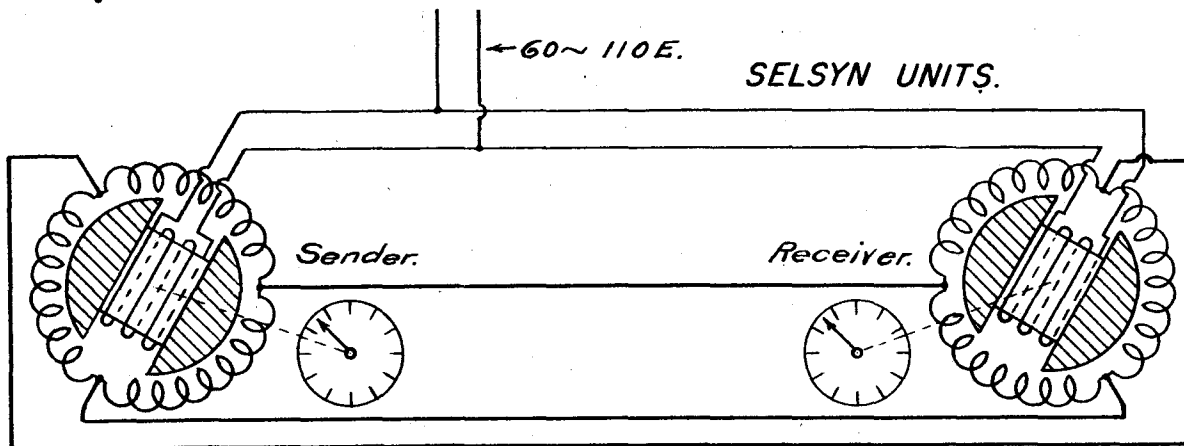

Diagram C shows a bridge type circuit in which the meter needle is returned to zero by manipulating a rheostat at the receiving end. When balanced, both rheostat arms are in identical positions.



There are many other circuit arrangements but the basic operating principle is the same. The electrical method is particularly suited to most applications because the units may be any distance apart, and several receivers may be attached to one sender.



If two small motors of the type shown above are connected together and the rotors are energized from a single phase A.C. source, the varying flux produced by the rotors will induce voltages in the stator windings. If the rotors are in identical positions, the induced stator voltages will be in direct opposition and no current will flow in the leads connecting the stators together. Should one rotor be moved, this voltage balance is disturbed and current will flow through the other stator winding in such a direction as to cause its rotor to move to a corresponding position. This self synchronizing action which is characteristic of many types of A.C. motors is utilized in the Selsyn position indicator.

With the indicators arranged as shown, movement of the sender rotor is duplicated by the receiver and, whether the sender is rotated through a small angle or several revolutions, the receiver follows the motion exactly. Where several indications are required, several receivers may be attached to the same sender. In this way motion of the sender may be reproduced at any number of remote points.

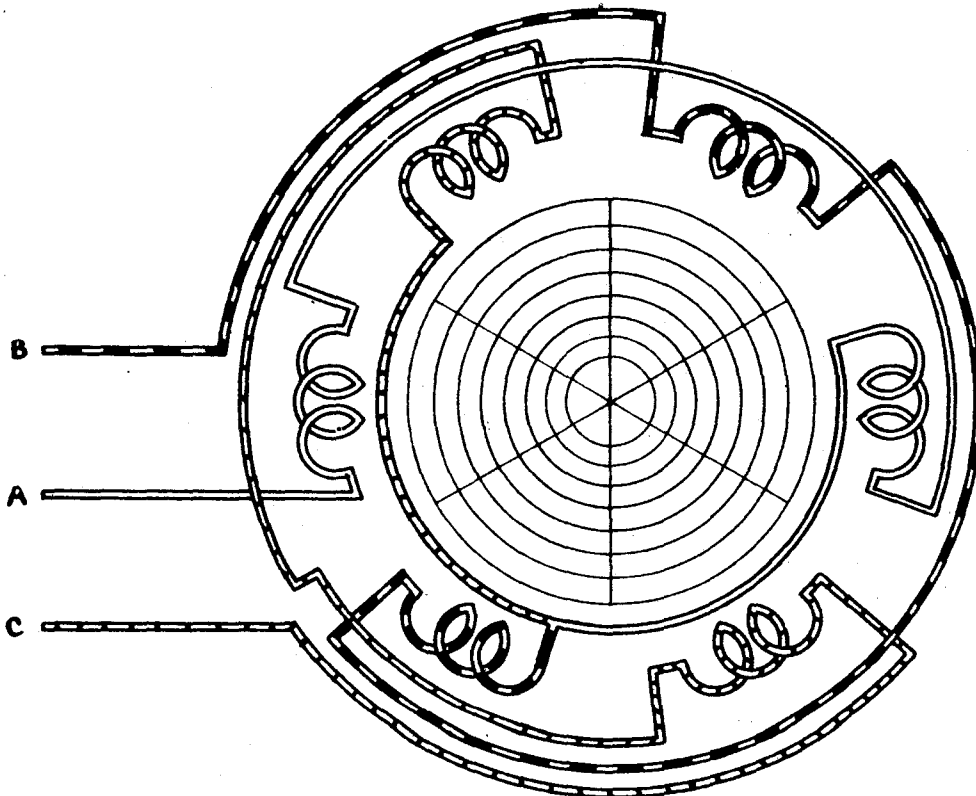
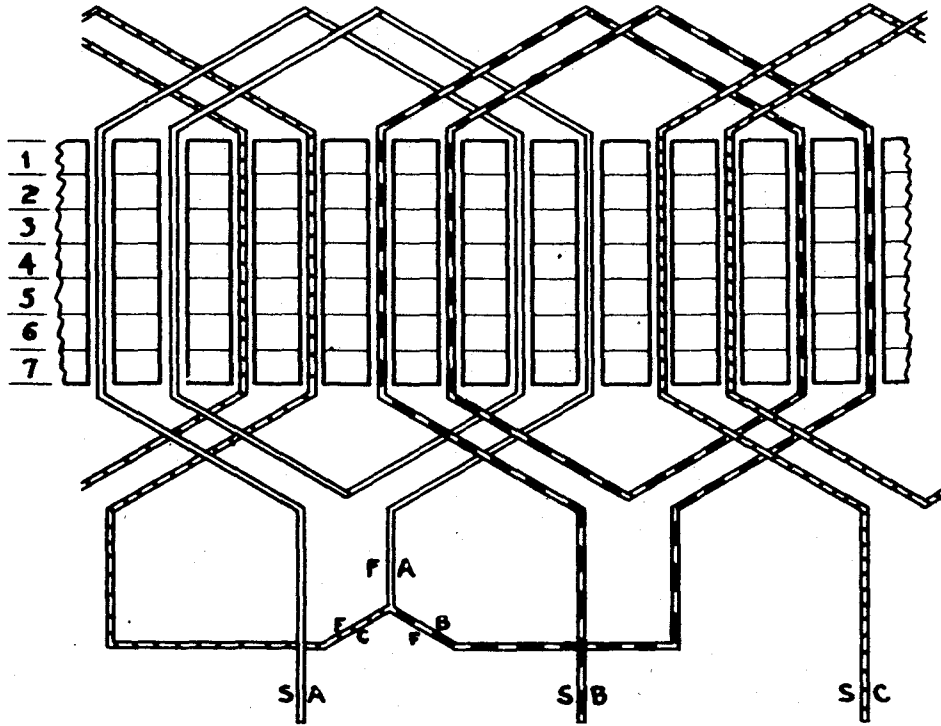
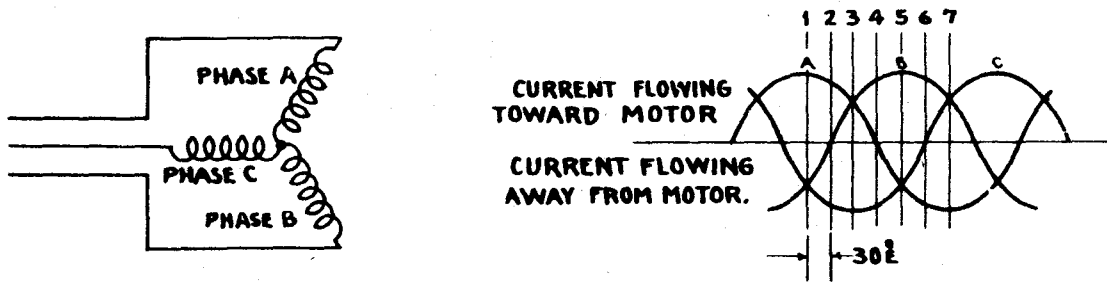

ASSUME CURRENT FLOWING CLOCKWISE TO SET UP A SOUTH POLE, AND CURRENT FLOWING COUNTER-CLOCKWISE TO SET UP A NORTH POLE

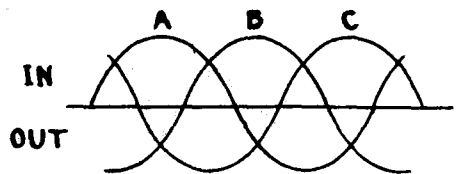

THREE PHASE, LAP WINDING, FULL PITCH, SLOTS = 24
 POLES = 4, PHASE = 3, COILS PER GROUP = 2
 FULL PITCH COIL SPAN = 1-7, ELECT. DEGREES PER SLOT = 30

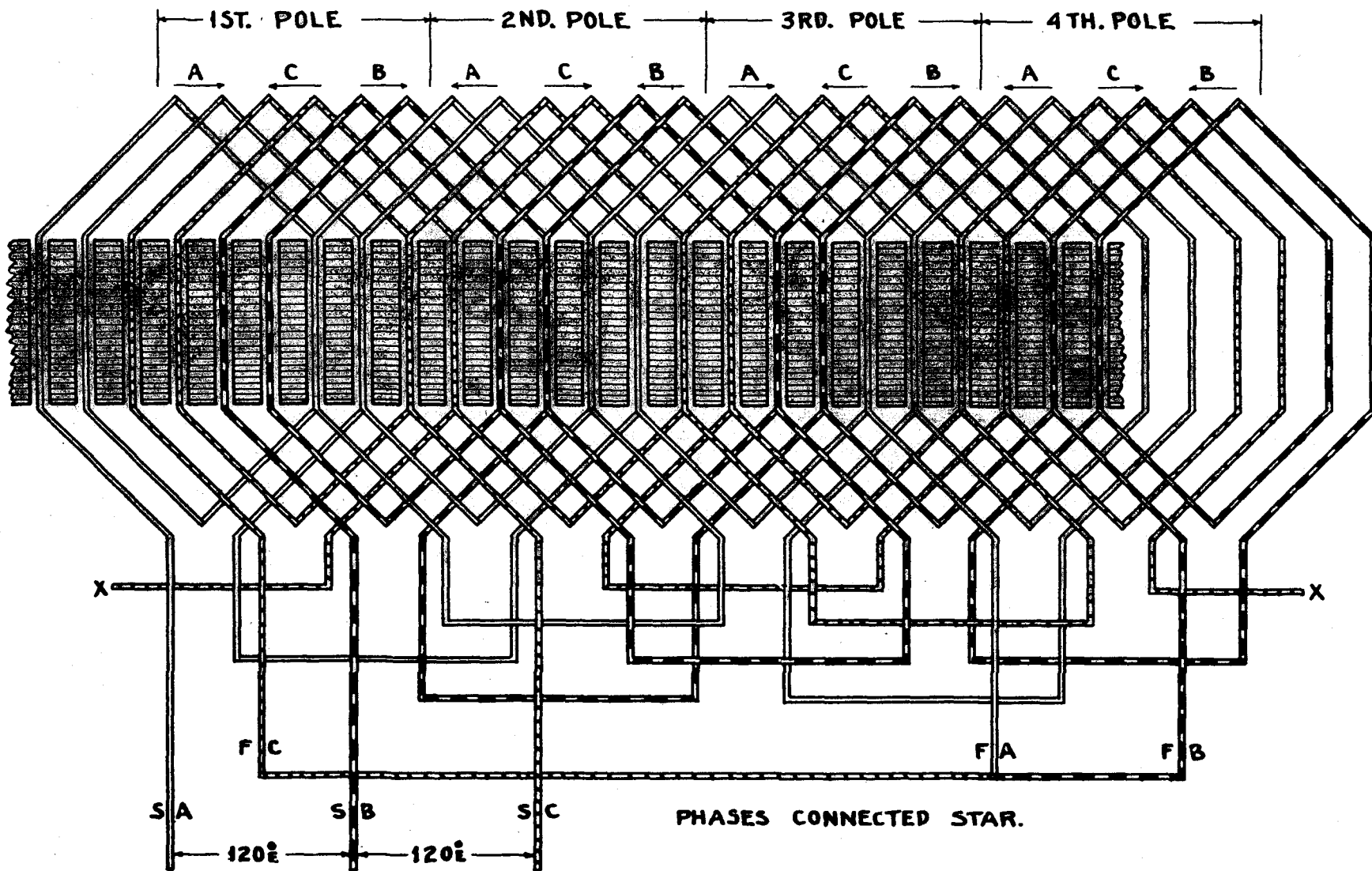

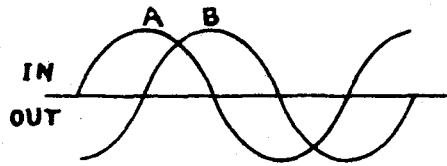

TWO PHASE, LAP WINDING, FULL PITCH, SLOTS = 24
 POLES = 4, PHASE = 2, COILS PER GROUP = 3
 FULL PITCH COIL SPAN = 1-7, ELECT. DEGREES PER SLOT = 30

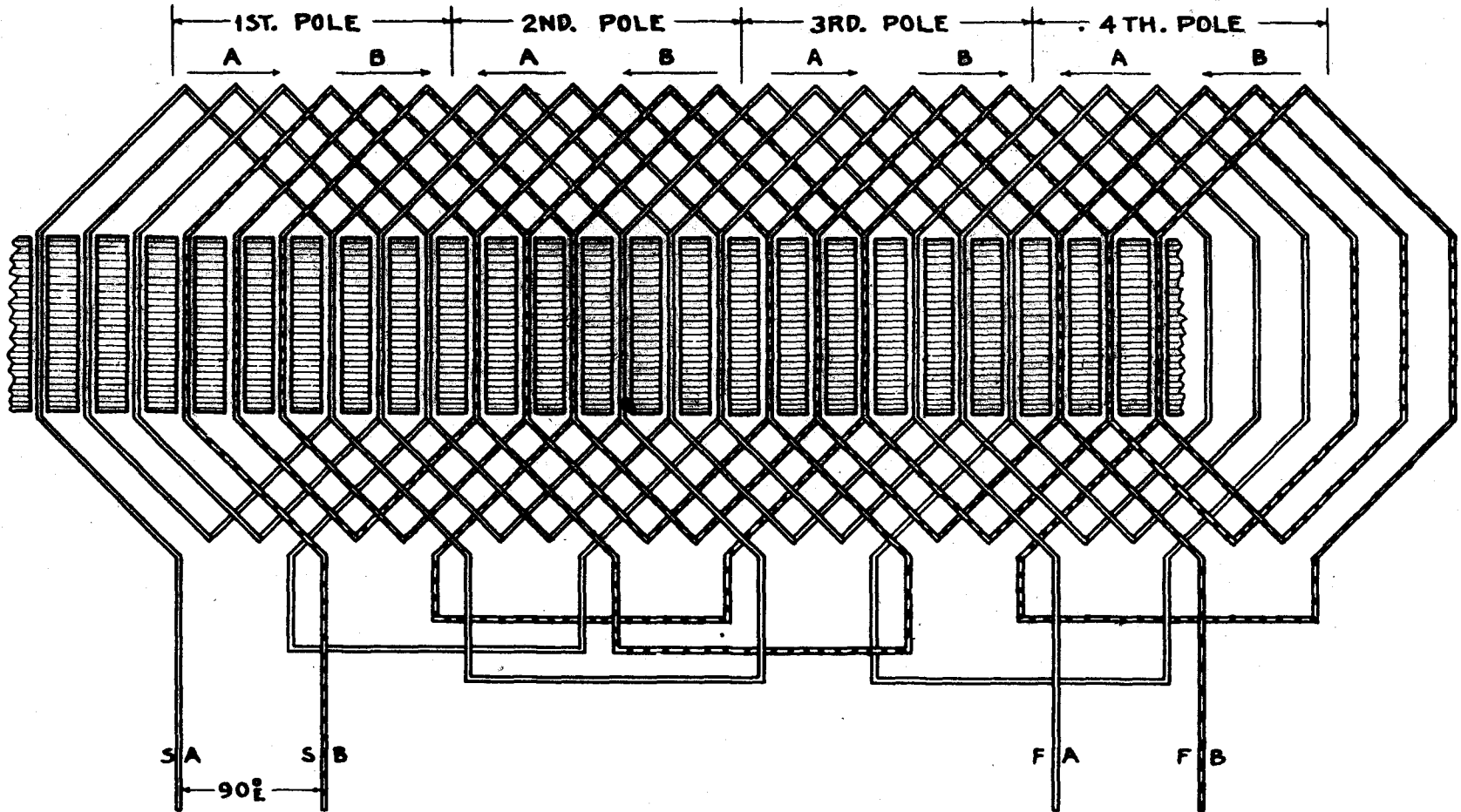

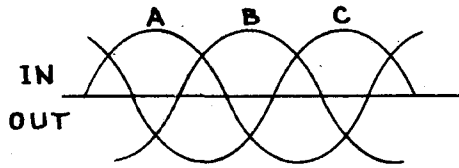

THREE PHASE, LAP WINDING, FULL PITCH, SLOTS = 24
 POLES = 4, PHASE = 3, COILS PER GROUP = 2
 FULL PITCH COIL SPAN = 1-7, ELECT. DEGREES PER SLOT = 30

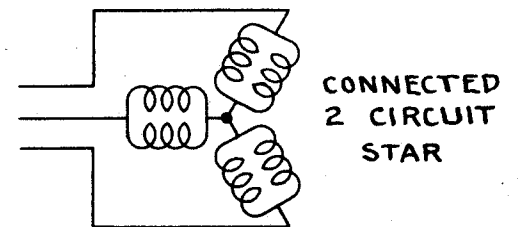
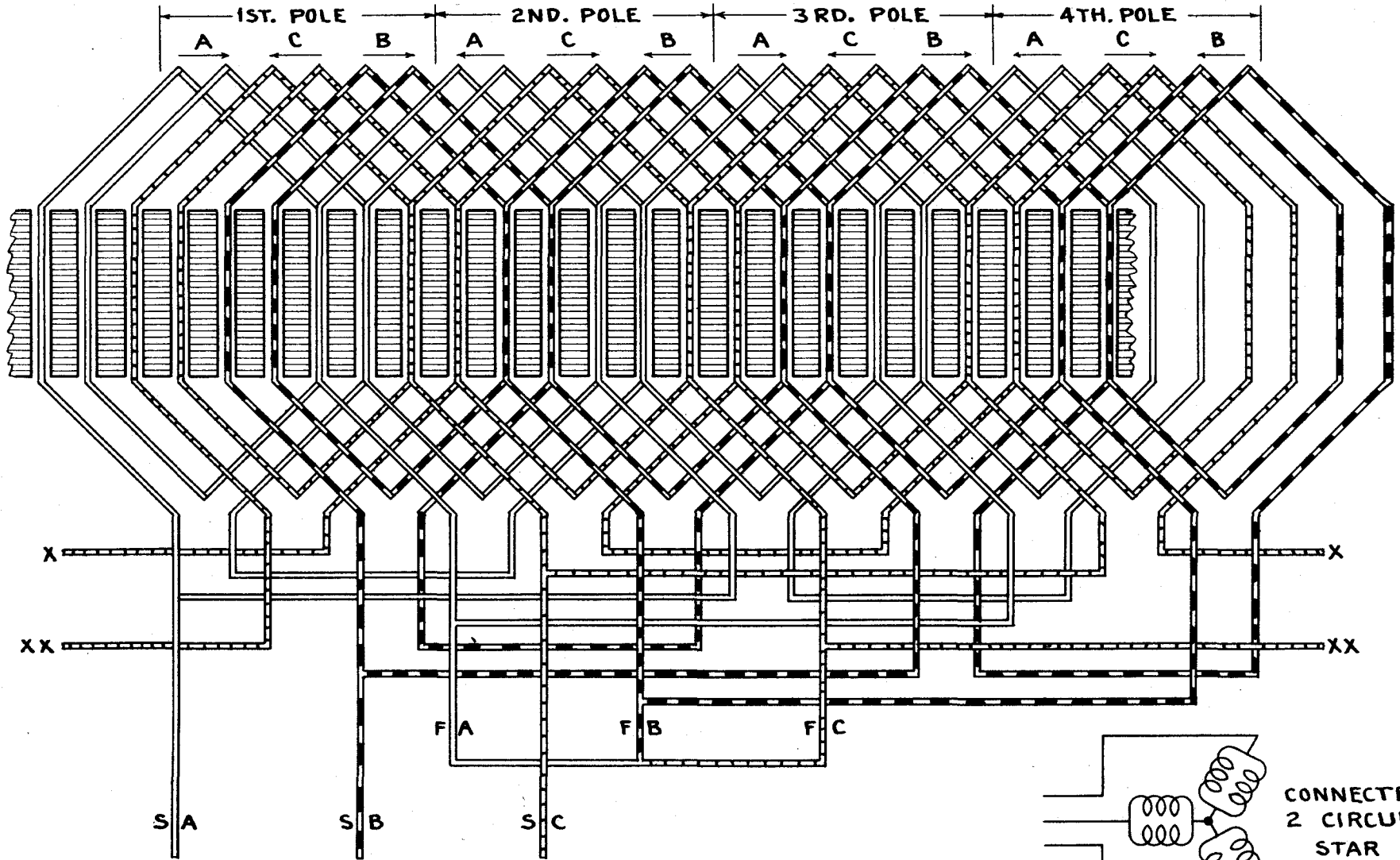

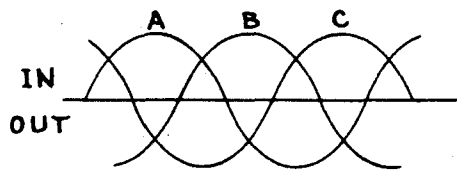

THREE PHASE , LAP WINDING , FULL PITCH , SLOTS = 24
 POLES = 4 , PHASE = 3 , COILS PER GROUP = 2
 FULL PITCH COIL SPAN=1-7 , ELECT. DEGREES PER SLOT = 30

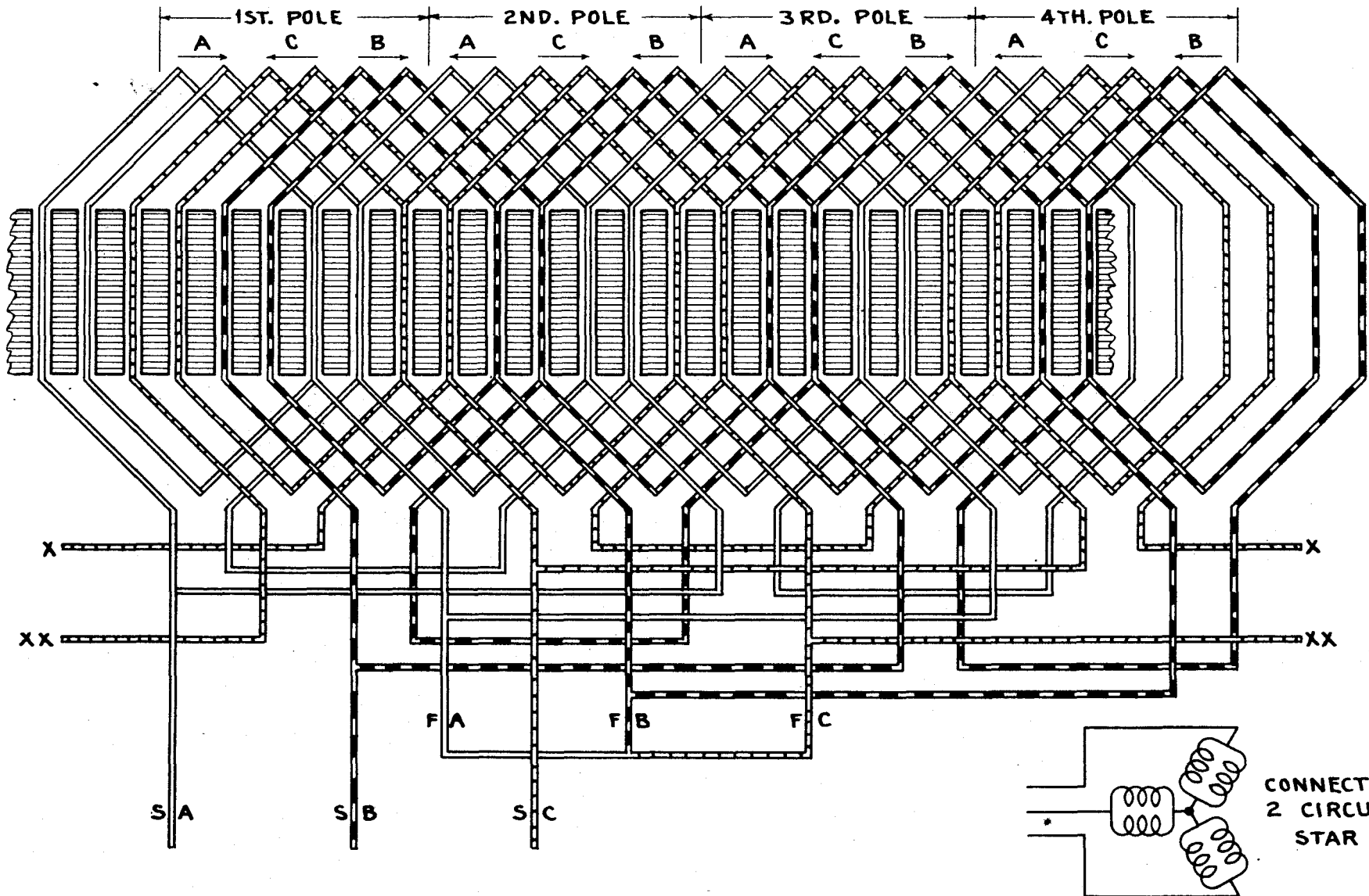

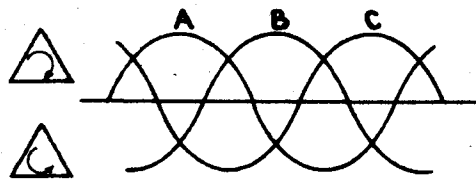

THREE PHASE, LAP WINDING, FRACTIONAL PITCH, SLOTS = 24
 POLES = 4 , PHASE = 3 COILS PER GROUP = 2
 FRACTIONAL PITCH COIL SPAN = 1-5, ELECT. DEGREES PER SLOT = 30

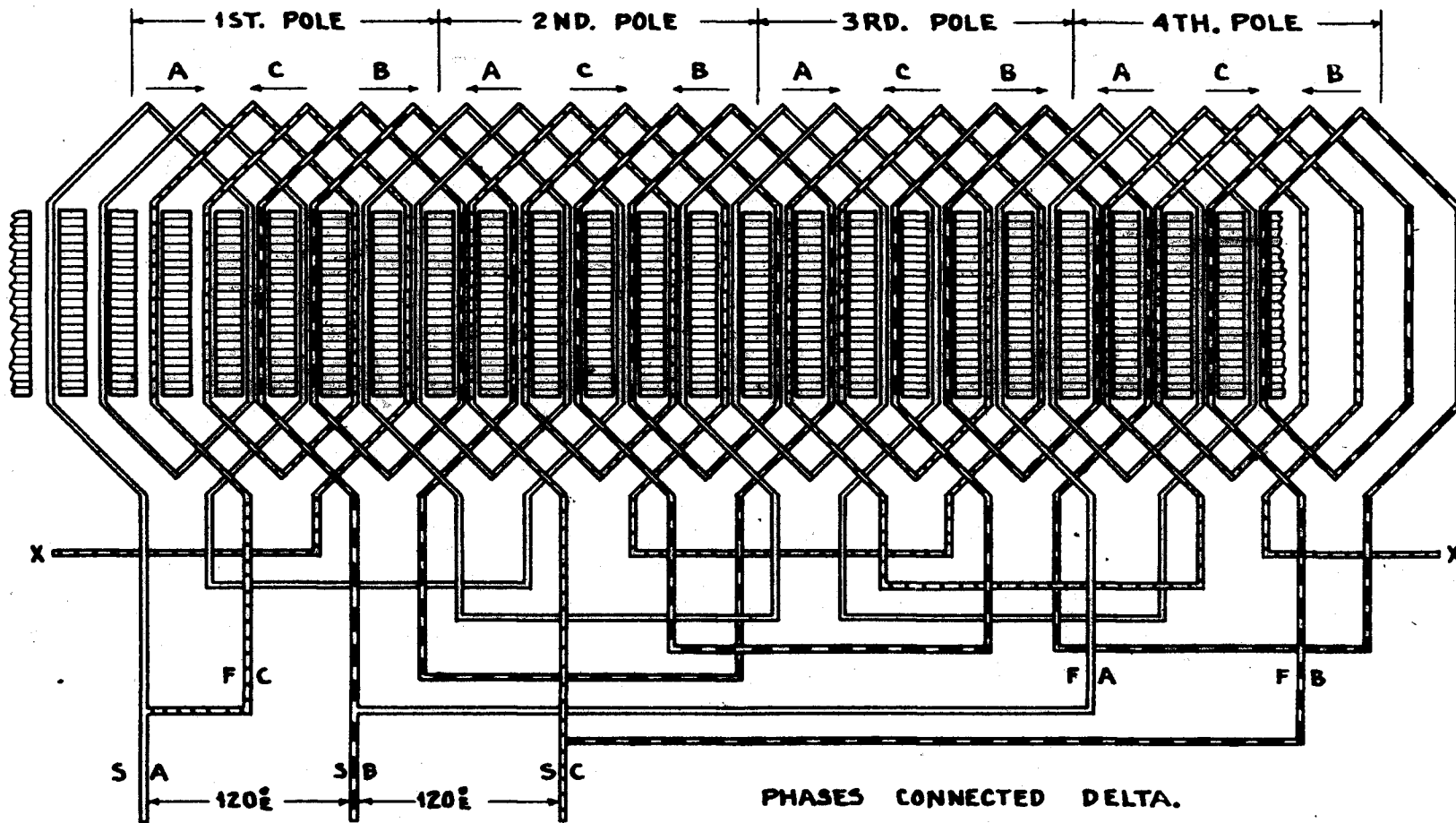

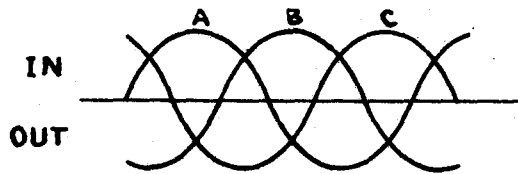

THREE PHASE, LAP WINDING , FULL PITCH, SLOTS = 36
 POLES = 6 , PHASE = 3 , COILS PER GROUP = 2
 FULL PITCH COIL SPAN = 1-7, ELECTRICAL DEGREES PER SLOT = 30

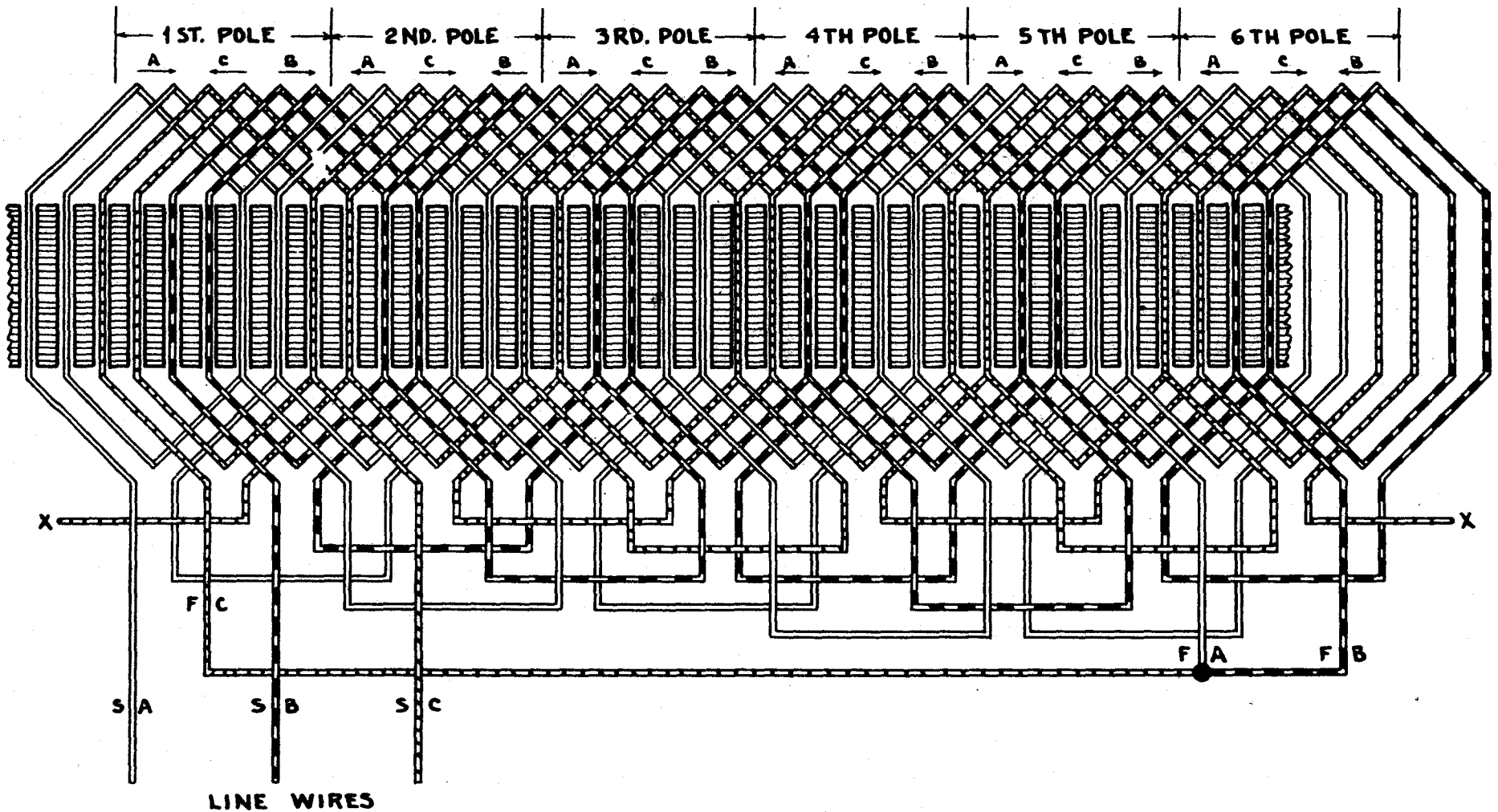

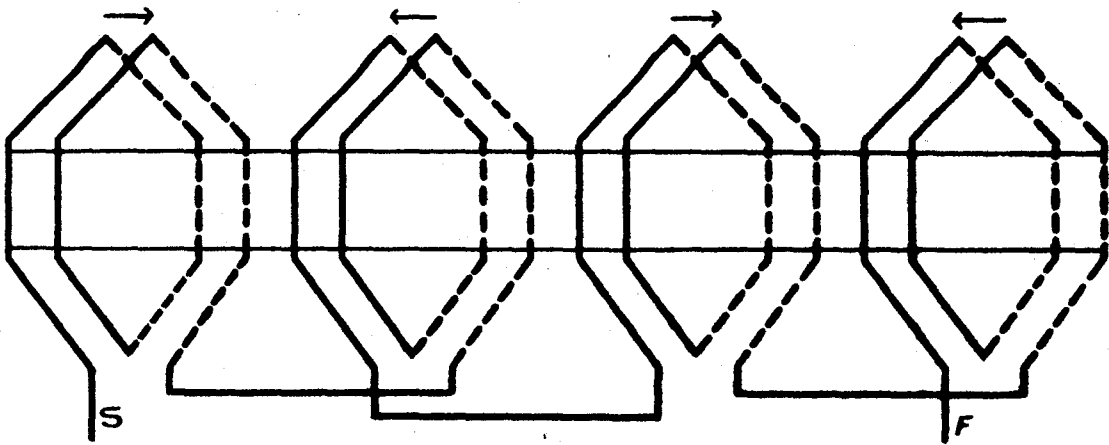

Slots = 24, Poles = 4, Fractional Pitch Coil Span = 1 to 5.

"A" Phase only of a 3 phase winding illustrating common method of short jumpers. (Top to Top, Bottom to Bottom) Trace the circuit and mark the polarities in the proper position. This type of jumper connection is not suitable for consequent pole windings.

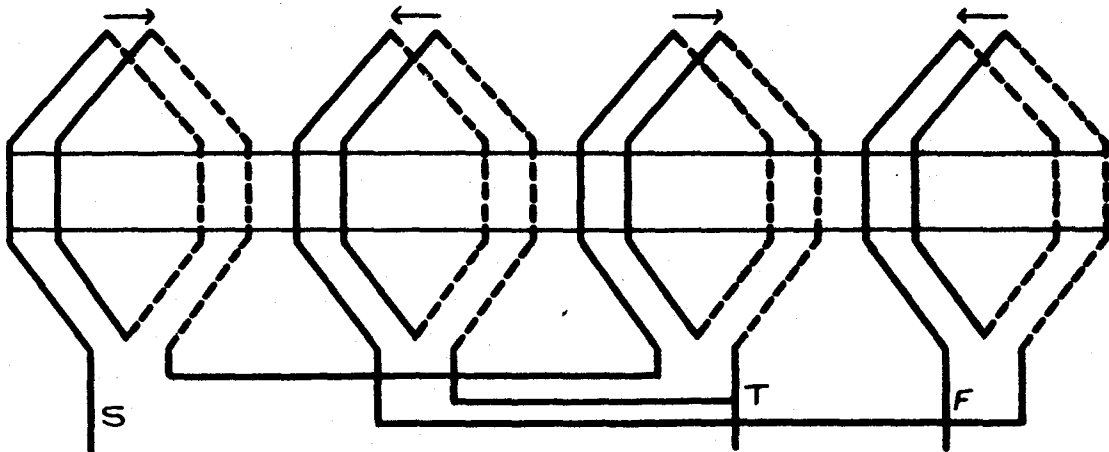

"A" Phase only of 3 phase winding illustrating long jumper method of connection. (Top to Bottom, Bottom to Top) Trace the circuit for 4 poles disregarding the center tap, and mark the polarities in the proper position. Note that the poles are established in the same position as for the common method of connection.

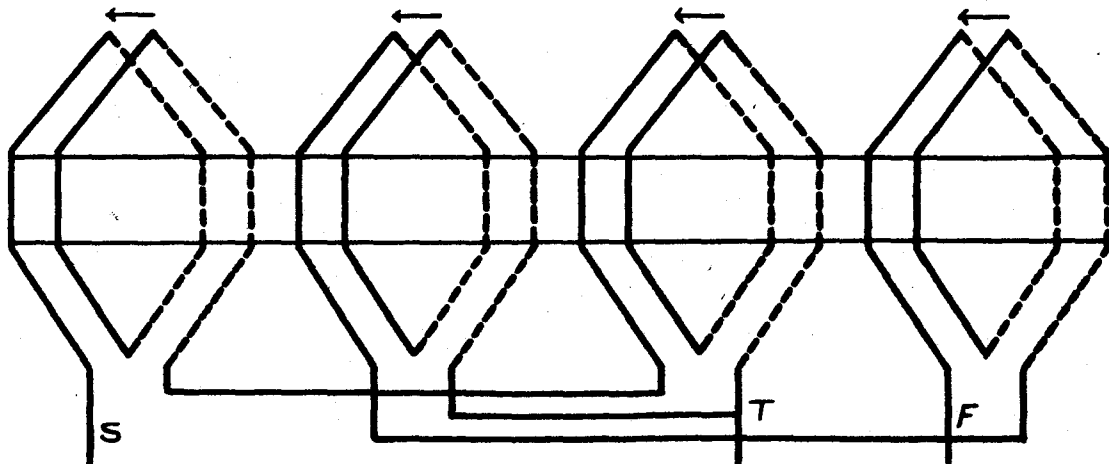

Same connection as shown above. Trace the circuit from the center tap. This places the 2 sections of the phase winding in parallel, reversing the current in $\frac{1}{2}$ of the coil groups, producing 4 regular & 4 consequent poles. Note that phase rotation is reversed and it will be necessary to reverse 2 leads on this connection to obtain the same rotor rotation.

SIMPLE DIAGRAM, 4-8 POLE, 3 PHASE CONSEQUENT POLE STATOR WINDING.

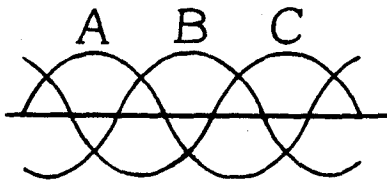

VARIABLE TORQUE, CONSTANT HORSEPOWER.
 3 PHASE, LAP WINDING, SLOTS = 24.
 POLES = 4-8, COILS PER GROUP = 2.
 FRACTIONAL PITCH COIL SPAN = 1 TO 5.
 COIL PITCH = 66.6% OF FULL PITCH.
 ELECTRICAL DEGREES PER SLOT = 30-60.

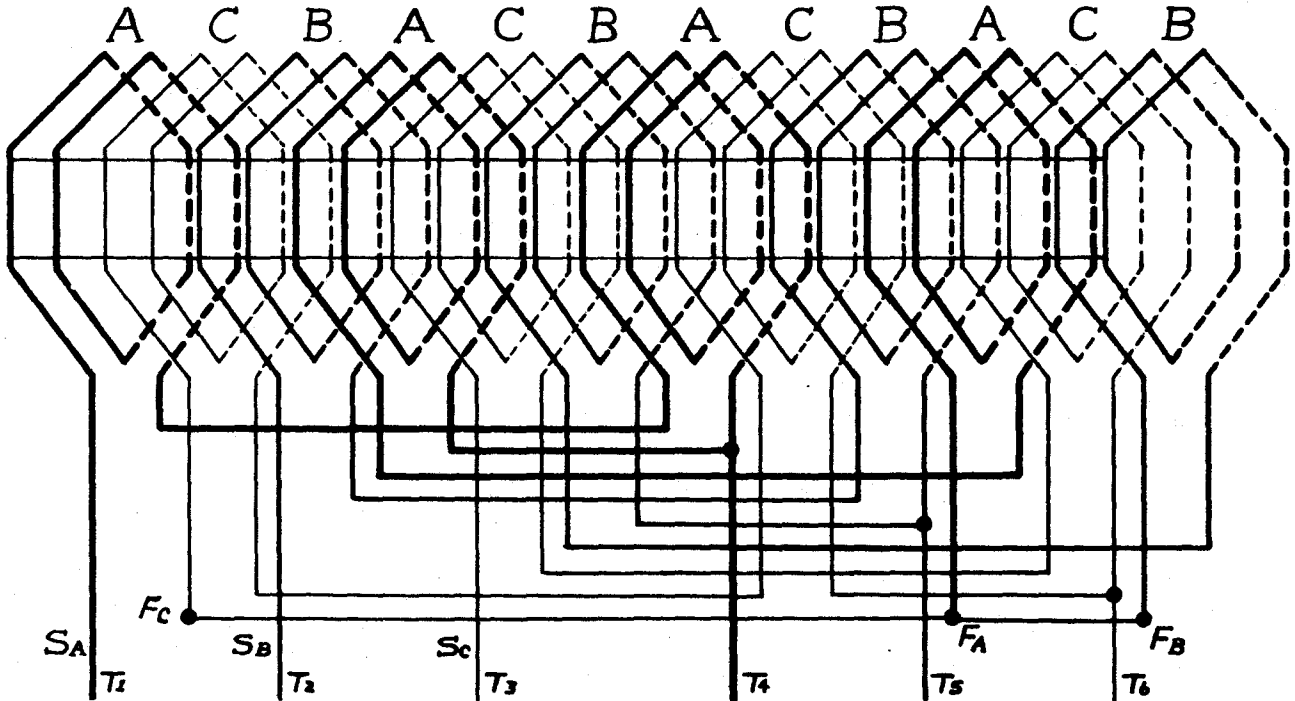

INDICATE DIRECTION OF I FLOW AND POLARITIES FOR 4 POLES IN SPACE BELOW.



INDICATE DIRECTION OF I FLOW AND POLARITIES FOR 8 POLES IN SPACE BELOW.

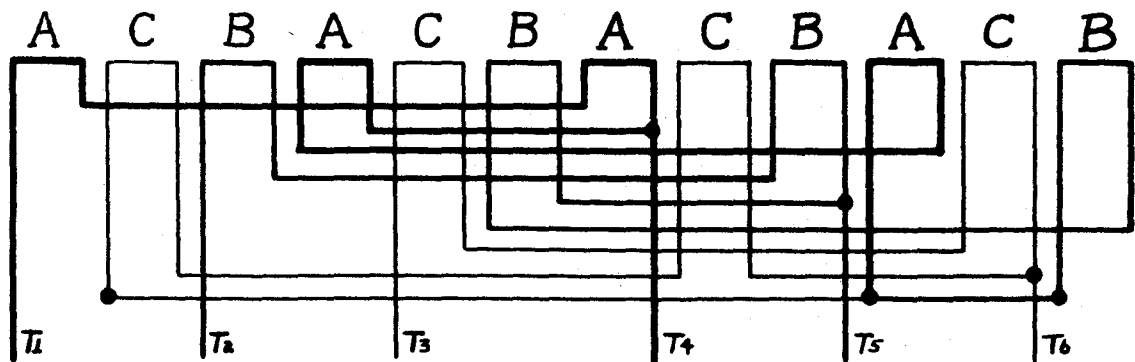

SERIES STAR
 4 POLES
 T₁, T₂, T₃ TO LINE
 T₄, T₅, T₆ OPEN

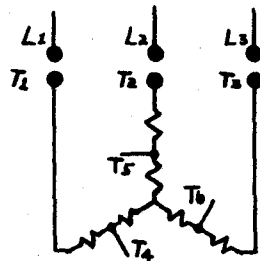

PARALLEL STAR
 8 POLES
 T₄, T₅, T₆ TO LINE
 T₁, T₂, T₃ SHORTED

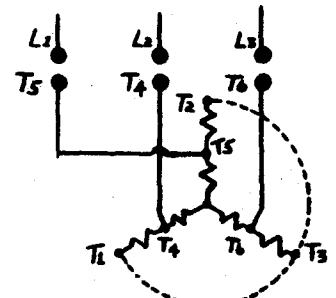

COMPARISON OF LAP AND WAVE WINDINGS.

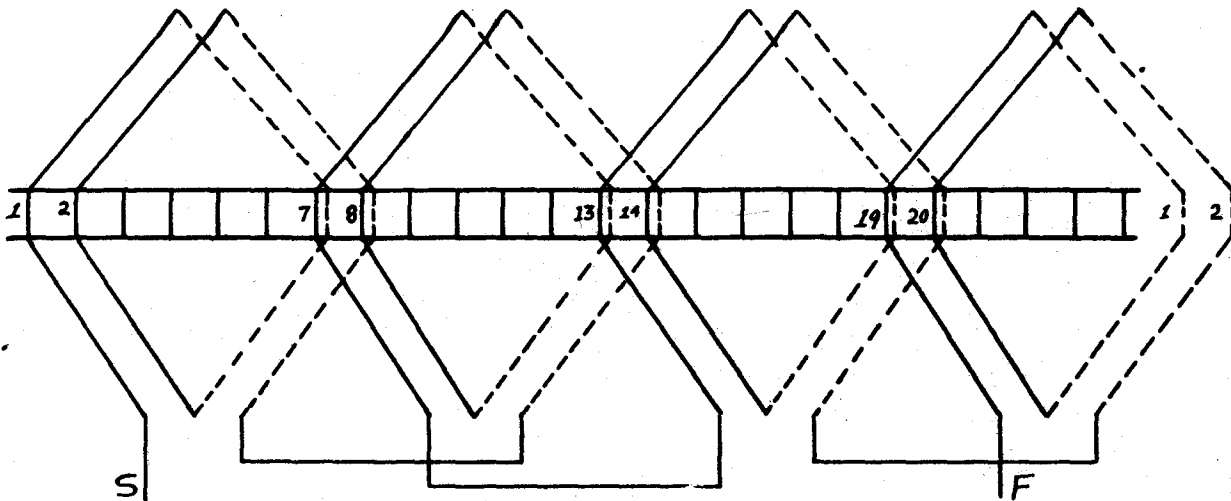

A LAP WINDING is one in which the coils of each pole phase group are connected directly in series with each other or forward and back on itself. Lap windings are generally used on A.C. machines because they are more readily adaptable to stators with various numbers of slots.

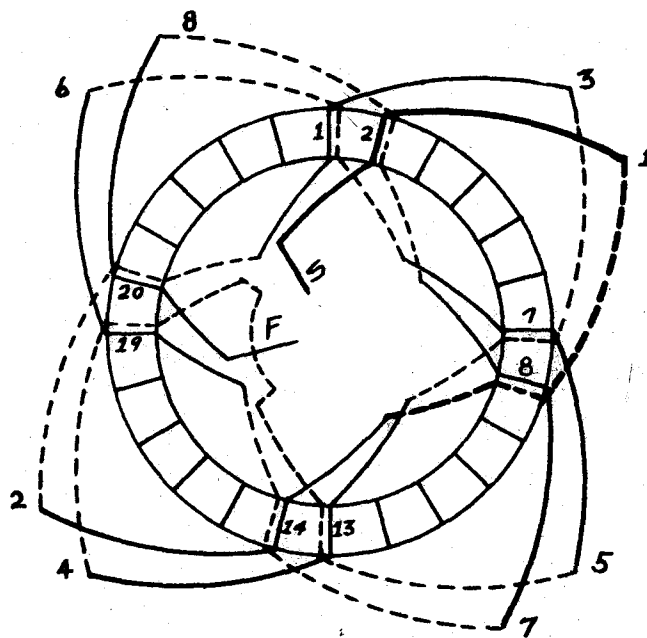

A WAVE WINDING is one in which correspondingly placed coils under adjacent poles are connected in series so that the circuit proceeds from pole to pole one or more times around the stator core, and not forward and back upon itself as on a lap winding. On a wave winding, the circuit re-enters the first coil group after it has passed thru at least one other coil group of the winding. The total number of these circuits must be a multiple of the number of phases and is ordinarily two times the number of phases. Wave windings in large machines are always of strap or bar copper coils with two layers. Principal use is for wound rotors of large slip ring motors because such windings have greater mechanical strength at end connections when made of bar or strap copper. WAVE WINDINGS in stators of induction motors must be electrically balanced, i.e., each phase must contain the same number of coils or turns. The number of active slots in each phase and section must be a multiple of poles times phases. For 4 pole, 3-phase, slots would have to be 12-24-36-48-60-72, etc.

THREE PHASE WAVE WINDING.

PHASES CONNECTED STAR.

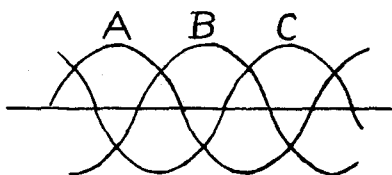
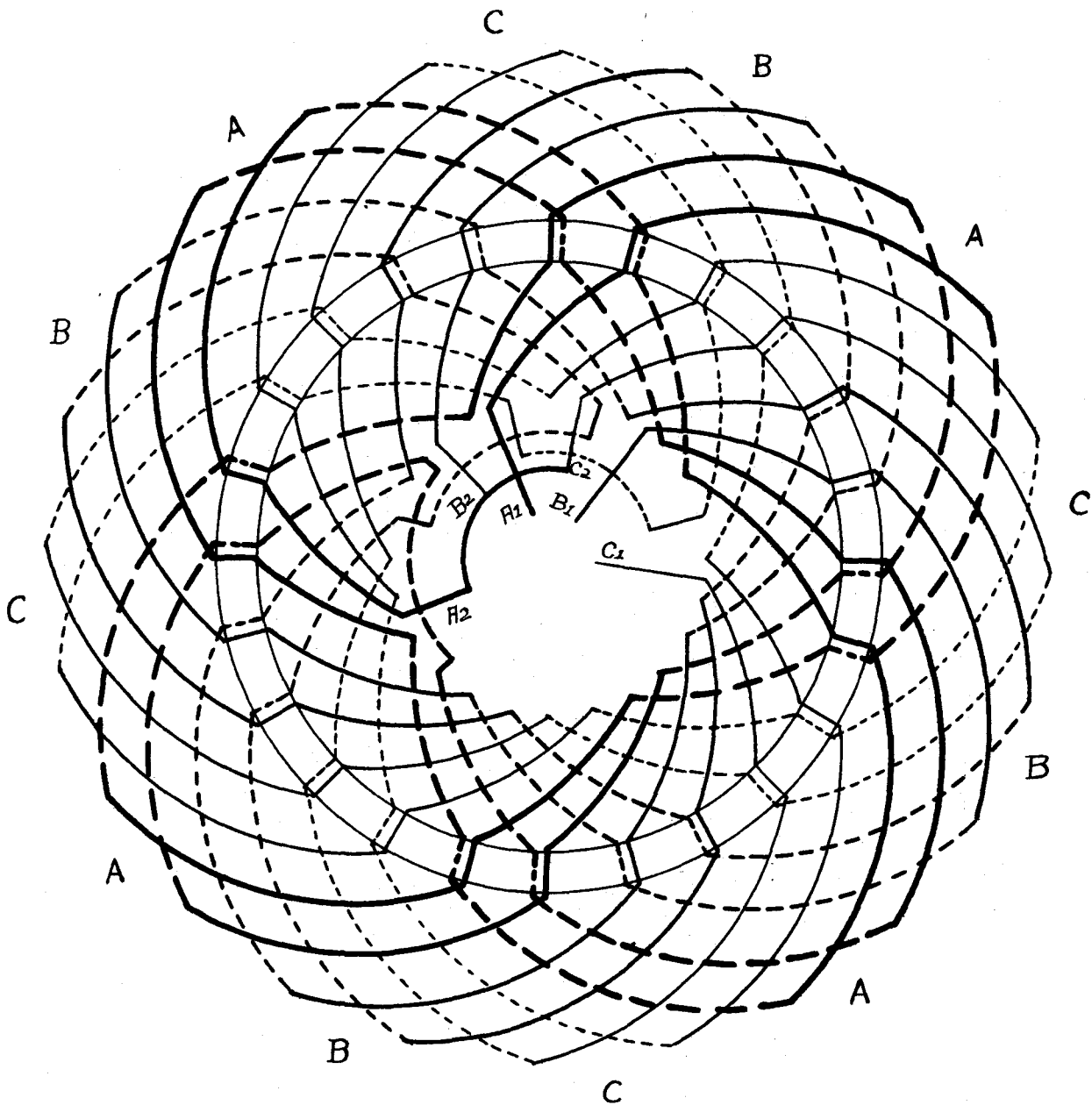

THREE PHASE, WAVE WINDING.

SLOTS = 24, POLES = 4.

FULL PITCH COIL SPAN = 1:7.

COILS PER POLE PHASE GROUP = 2.

ELECTRICAL DEGREES PER SLOT = 30.

CONNECTIONS FOR TWO VOLTAGE MOTORS.

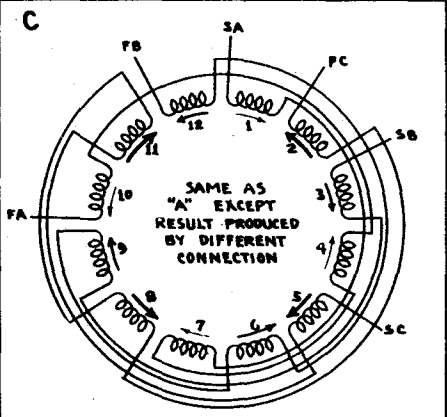
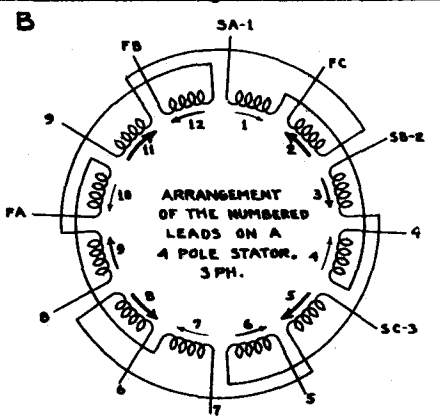
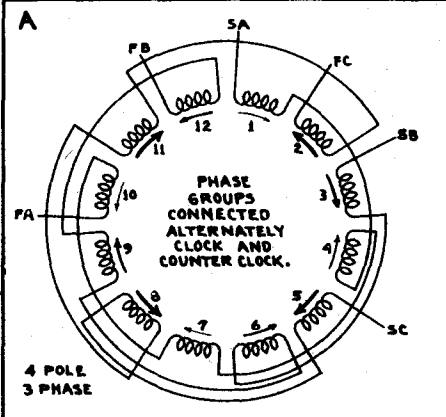
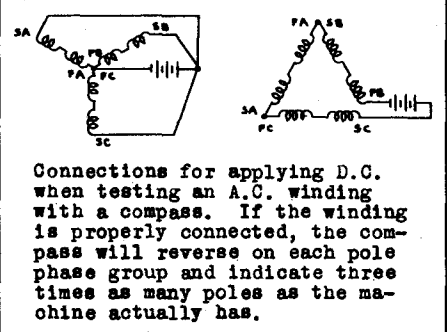
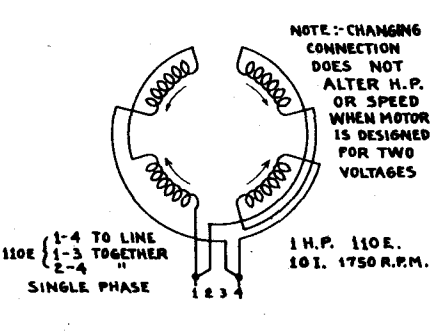
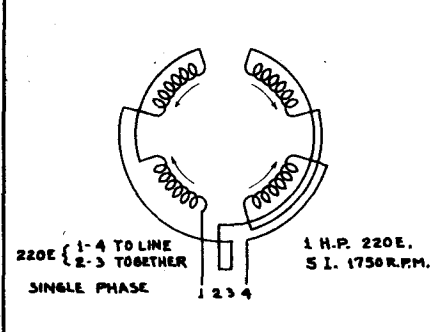
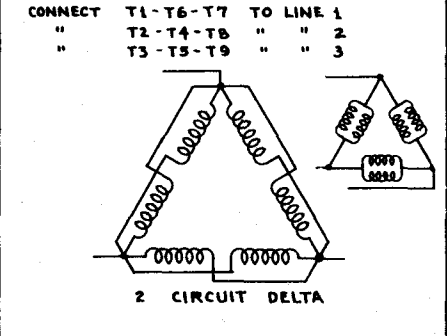
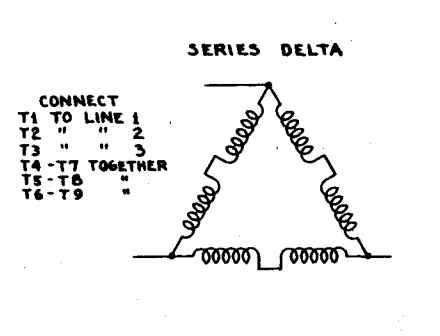
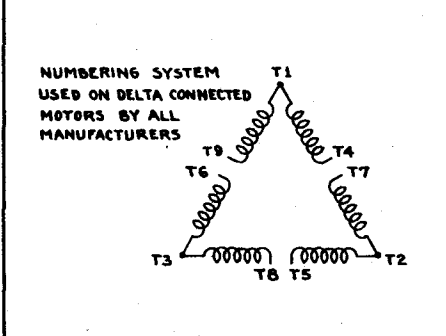
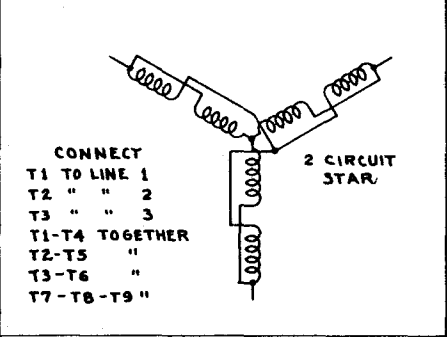
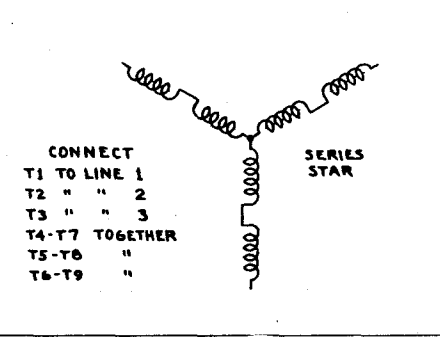
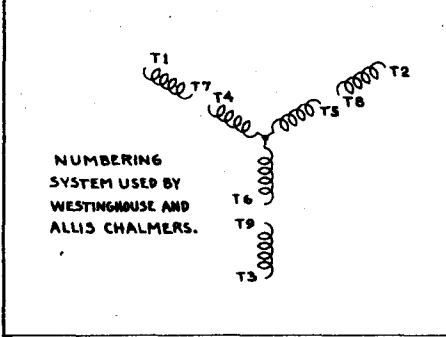
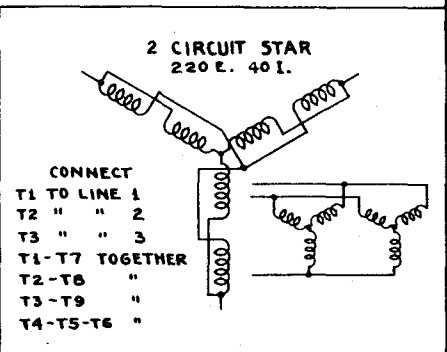
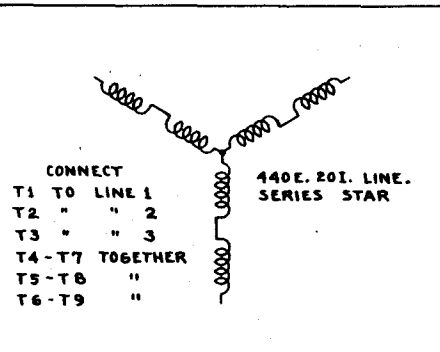
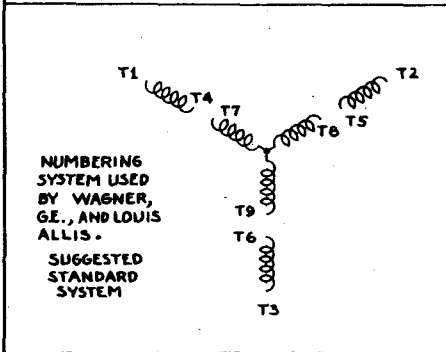

REDRAW "A," "B" AND "C" AND PRACTICE CONNECTING THEM FOR ALL ABOVE CONNECTIONS.

STAR OR Y
CONNECTED



ENGINEERING INFORMATION

POLYPHASE INDUCTION MOTORS

TYPES SC, SCN, SCH, SCT, SCX, AS, SR - 3 PHASE

Three Phase motors may be either Star or Delta connected and no general rule can be set down for use of either connection. Individual ratings must be checked by the general office.

Our standard method of marking leads and the schematic representation of circuits* is as follows:

DUAL VOLTAGE* (110/220, 190/380, 220/440 etc.)

Consider T_1 and T_4 (Fig. 1) as the end of one circuit* and T_7 and the center of the star as the ends of the other circuit, in one phase. Do the same for each of the other two phases. To connect the stator winding for the higher voltage, the circuits in each phase are connected in series; therefore, connect T_4 to T_7 , T_5 to T_8 , and T_6 to T_9 . Line connections will be made to T_1 , T_2 , and T_3 fig. 2 and 5 show these connections.

To connect the stator windings for the lower voltage, the circuits in each phase are connected in parallel, therefore connect T_1 to T_7 , T_2 to T_8 , and T_3 to T_9 . T_4 , T_5 and T_6 are connected together to form a point, thereby forming a second star in parallel with the star whose ends are T_7 , T_8 , and T_9 . Line connections, as before, will be made to T_1 , T_2 and T_3 . Fig. 3 and 6 show these connections.

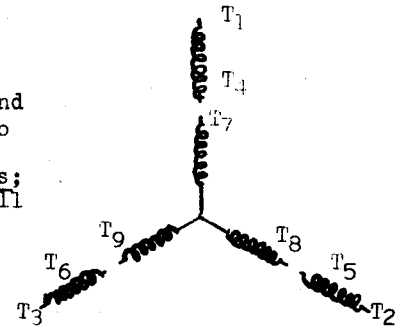

FIG. 1
All terminal lugs are stamped in accordance with this diagram.

These motors have permanent connection plate near terminal box.

SINGLE VOLTAGE* (199, 203, 220, 440, 550, 2200 etc.)

Only leads T_1 , T_2 and T_3 are brought out as shown in fig. 4 and 7 (Single voltage motors usually have single section windings rather than the double section winding shown in Fig. 1)

Connections are indicated on lubrication tags sent with motor.

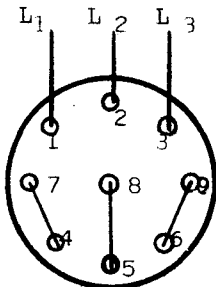

FIG. 2
High Voltage

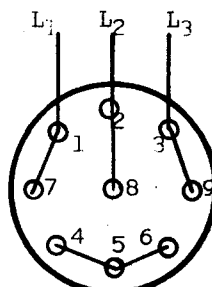

FIG. 3
Low Voltage

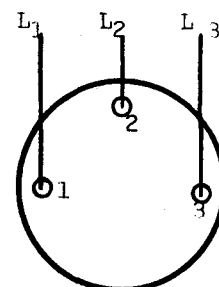

FIG. 4
Single Voltage

DUAL VOLTAGE CONNECTIONS (Similar to B6671 & B7203)

All Form A 204 and smaller; Form W, 224 to 326; Form T 204 and larger. (T superseded by W)

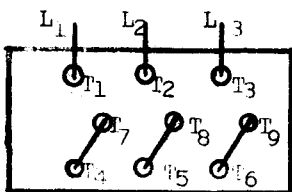

FIG. 5
High Voltage

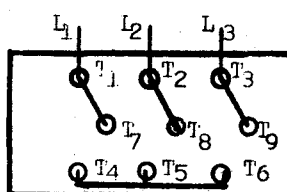

FIG. 6
Low Voltage

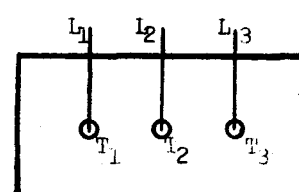

FIG. 7
Single Voltage

DUAL VOLTAGE CONNECTIONS (Similar to B4270 & B4271)

All Form S motors. Form T motors 444 and larger.



ENGINEERING INFORMATION

POLYPHASE INDUCTION MOTORS

TYPES SC, SCN, SCH, SCT, SCX, AS, SR - 2 PHASE

DATA 23-65 Page 3
Dec. 4, 1940
Destroy 23-101 P.3.
Dated Dec. 7, 1935

Our standard method of marking leads, and the schematic representation of circuits* is as follows:

TWO PHASE FOUR WIRE

DUAL VOLTAGE* (110/220, 220/440 etc.)

Consider T₁ and T₅ (Fig.15) as the ends of one circuit*, and T₇ and T₃ as the ends of the circuits in the second phase. To connect the stator windings for the higher voltage, the circuits in each phase are connected in series; therefore, connect T₅ to T₇, and T₆ to T₈. Line connections will be made to T₁, T₂, T₃ and T₄. FIGS. 16 and 19 show these connections.

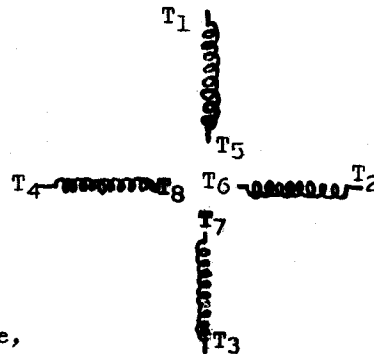

FIG. 15

All terminal lugs are stamped in accordance with this diagram.

To connect the stator windings for the lower voltage, the circuits in each phase are connected in parallel; therefore, connect T₁ to T₇, T₅ to T₃, T₂ to T₈, and T₆ to T₄. Line connection, as before, will be made to T₁, T₂, T₃ and T₄. Figs 17 and 20 show these connections.

These motors have permanent connection plate near terminal box.

SINGLE VOLTAGE* (199, 208, 220, 440, 550, 2200 etc.)

Only leads T₁, T₂ and T₃ are brought out as shown in Fig. 18 and 7 (Single voltage motors usually have single section windings rather than the double section winding shown in Fig. 15)

Connections are indicated on lubrication tags sent with motor

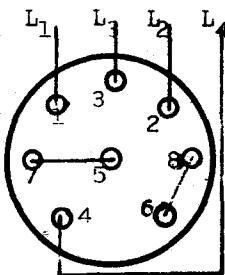

FIG. 16
High Voltage

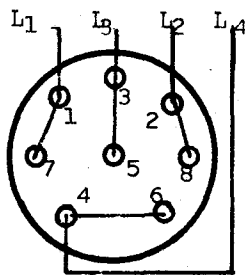

FIG. 17
Low Voltage

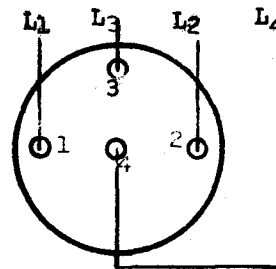

FIG. 18
Single Voltage

DUAL VOLTAGE CONNECTIONS (Similar to B6672 & B7204)

All Form A 204 and smaller; Form W, 224 to 326; Form T 204 and larger (T superseded W)

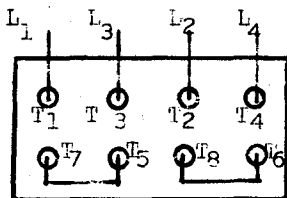

FIG. 19
High Voltage

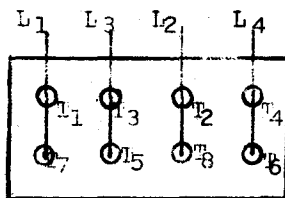

FIG. 20
Low Voltage

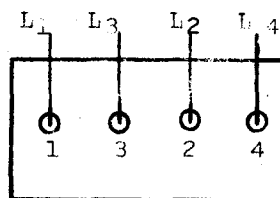

FIG. 21
Single Voltage

DUAL VOLTAGE CONNECTIONS (Similar to B4269 & B4272)

All Form S motors. Form T motors 444 and larger.

TWO PHASE THREE WIRE

For connection to a three wire system, connect motor leads T₃ and T₂, together. Line connections will then be made to T₁, T₃₋₂, and T₄; the common (or return wire) being connected to T₃₋₂.

- * - The terms "circuit" as here used refers to one-half of the number of poles in one phase.
- * - See price sheet for standard voltage and horsepower of individual ratings.



ENGINEERING INFORMATION
 CONNECTION PLATES MULTI-SPEED SQUIRREL CAGE MOTORS
 2 SPEED 1 AND 2 WINDINGS

THESE LEAD MARKINGS APPLY TO MOTORS MADE IN 1940 AND LATER

3 PHASE

STAMPING OF AUXILIARY NAME PLATE 2 SPEED 1 WINDING 3 PHASE

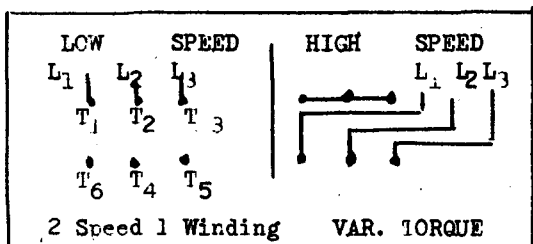

SIMILAR TO B4494

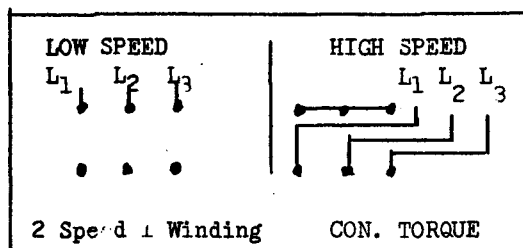

SIMILAR TO B4494

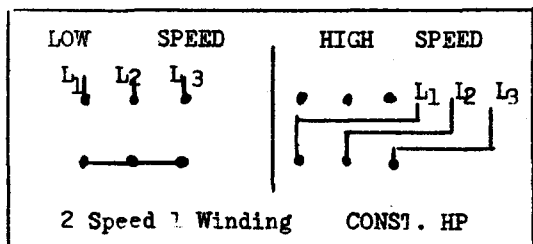

SIMILAR TO C17131

AUXILIARY NAME PLATE 2 SPEED 2 WINDING 3 PHASE

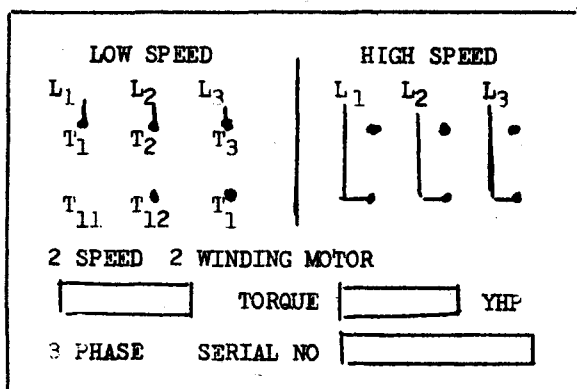

SIMILAR TO B4248

THESE DIAGRAMS ARE REPRODUCTIONS OF PLATES ATTACHED TO MOTORS WHEN THEY LEAVE THE FACTORY.



ENGINEERING INFORMATION
CONNECTION PLATES MULTI-SPEED SQUIRREL CAGE MOTORS
3 SPEED - 2 WINDING - CONSTANT HP

THESE LEAD MARKINGS APPLY TO MOTORS MADE IN 1940 AND LATER

3 PHASE

AUXILIARY NAME PLATE 3 SPEED 2 WINDING CONSTANT HORSEPOWER
2-4-6; 4-8-12; 6-12-16 POLE

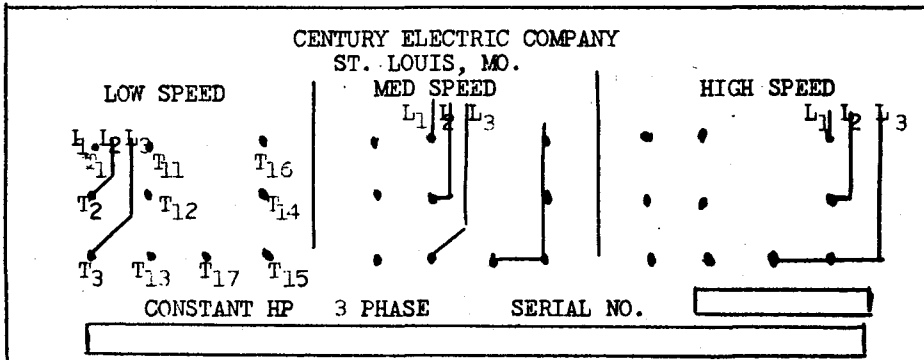

SIMILAR TO C17132

AUXILIARY NAME PLATE 3 SPEED 2 WINDING CONSTANT HORSEPOWER
4-6-8; 6-8-12; 8-12-16 POLE

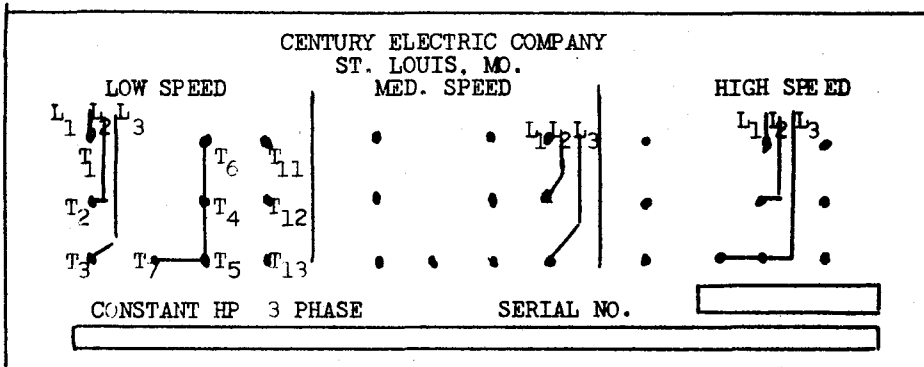

SIMILAR TO C17134

AUXILIARY NAME PLATE 3 SPEED 2 WINDING CONSTANT HORSEPOWER
4-6-12; 6-8-16 POLE

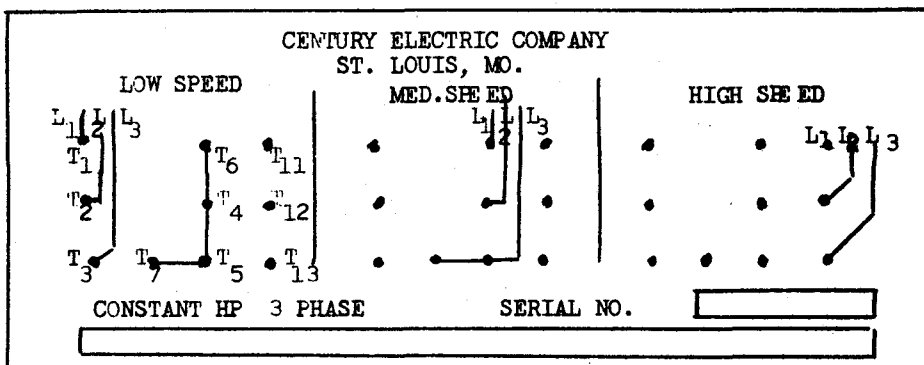



ENGINEERING INFORMATION
 CONNECTION PLATES MULTI-SPEED SQUIRREL CAGE MOTORS
 3 SPEED - 2 WINDING - VARIABLE TORQUE

3 PHASE

THESE LEAD MARKINGS APPLY TO MOTORS MADE IN 1940 AND LATER

AUXILIARY NAME PLATE 3 SPEED 2 WINDING VARIABLE TORQUE
 4-6-8; 6-8-12; 8-12-16 POLE

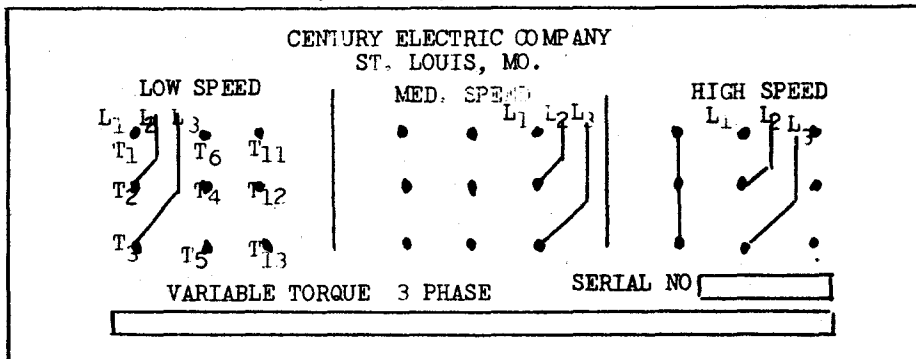

AUXILIARY NAME PLATE 3 SPEED 2 WINDING VARIABLE TORQUE
 4-6-12; 6-8-16 POLE

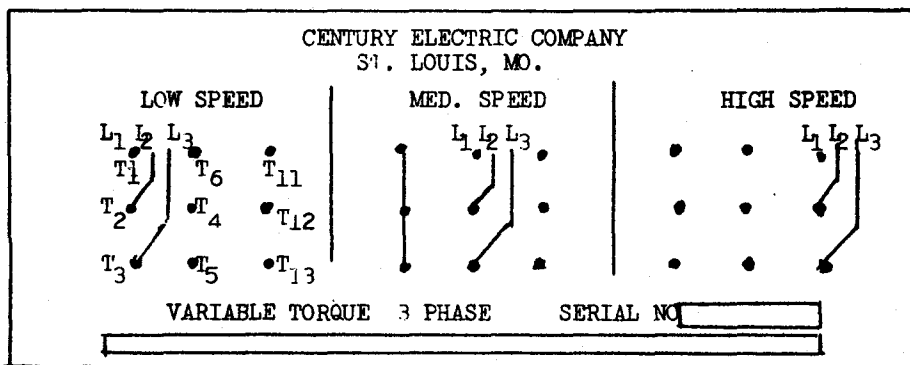

AUXILIARY NAME PLATE 3 SPEED 2 WINDING VARIABLE TORQUE
 2-4-6; 4-8-12; 6-12-16 POLE

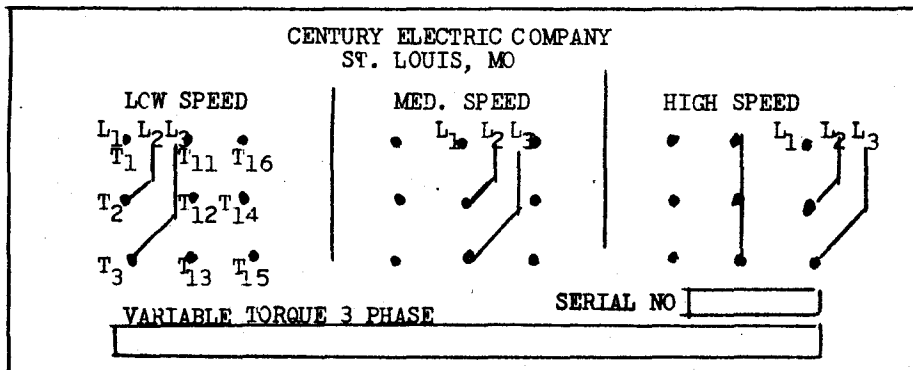

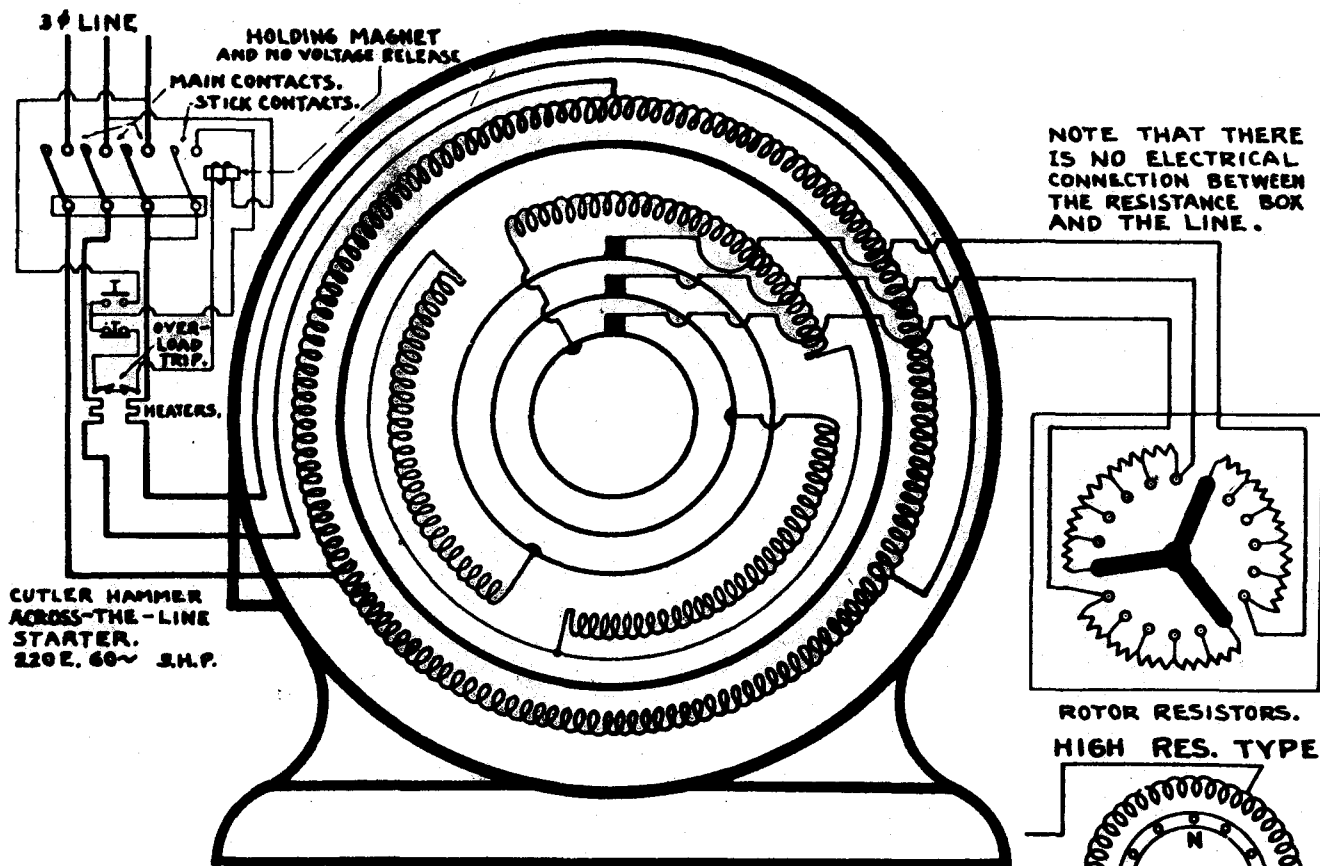

Diagrams A and B are used to show that an increase in rotor resistance causes the rotor poles to move into a more favorable position with respect to the stator poles thereby increasing the starting torque. If the rotor resistance is increased above a certain critical value, the torque will be reduced as indicated by the curves in the diagram below.

The slip ring induction motor operates on the same principle as the squirrel cage type, the revolving magnetic field set up by the stator winding reacting with the induced rotor poles to produce rotation. Insertion of resistance in the rotor circuit produces the following advantages: 1. High starting torque 2. Low starting current 3. Smooth starting action 4. Adjustable speed.

CHARACTERISTICS

The average slip ring motor will produce 3 times normal full load torque with 2.5 times normal full load current.

With all the external resistance cut out, the variation in speed from no load to full load will not exceed 5% of the full load speed. As resistance is inserted, the speed regulation becomes rapidly poorer

APPLICATION

Air compressors, large ventilating fans, conveyors, punch presses, printing presses, lathes, elevators, etc. may be used wherever a high starting torque, a smooth starting action, or adjustable speed is desired.

PRINCIPAL TROUBLES

Sliprings, brushes, brush holders, external rotor resistance, loose connections, bearings, insulation.

- CURVE "1" ROTOR RES. ALL CUT OUT.
- " "2" RES. FOR MAX. TORQUE.
- " "3" MORE RES. THAN "2"
- " "4" MORE RES. THAN "3"

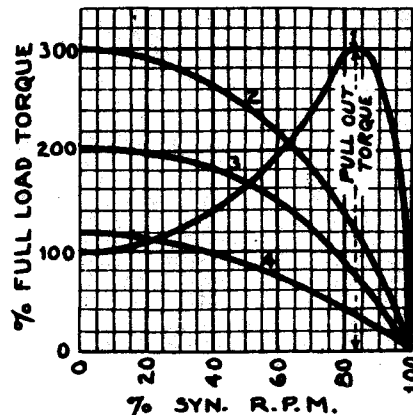

A.C. Single-phase Motors
Speed Adjustment

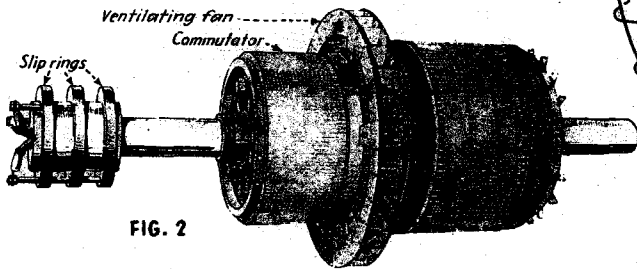
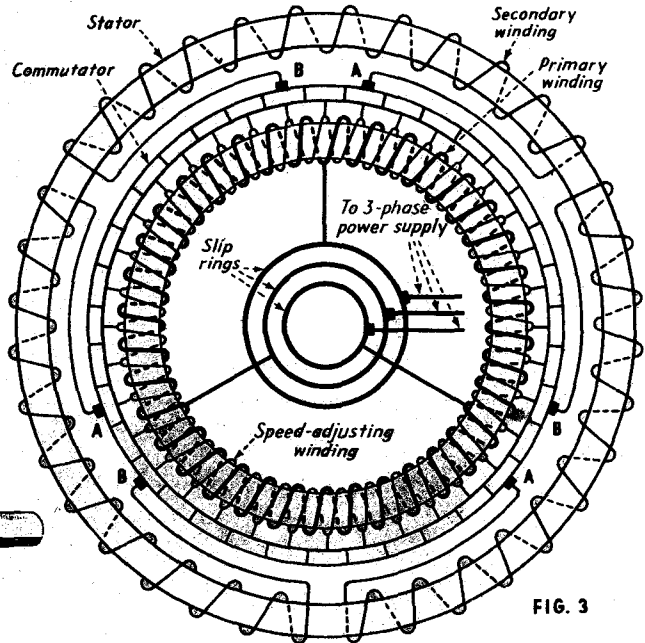
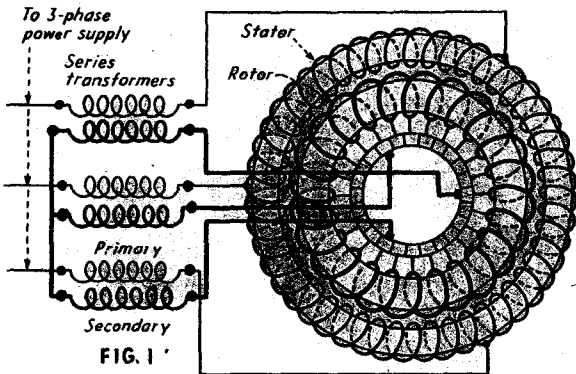

Fig. 1—Diagram of polyphase commutator motor, speed of which is varied by changing position of brushes. Fig. 2—Rotor for adjustable-speed polyphase motor. Fig. 3—Diagram of rotor and stator circuits for a polyphase adjustable-speed motor

Wound-Rotor Motors

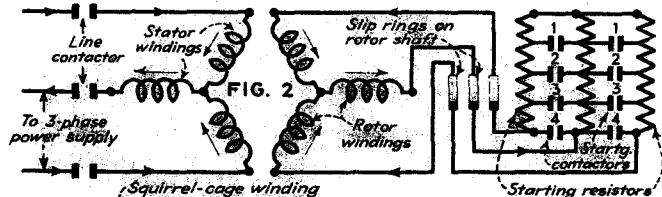
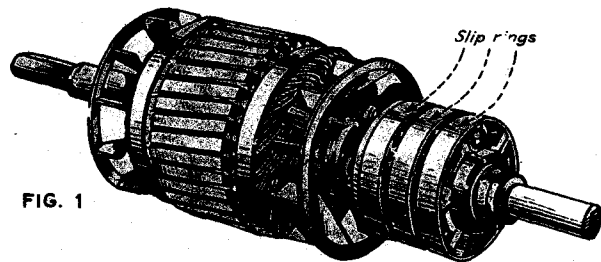
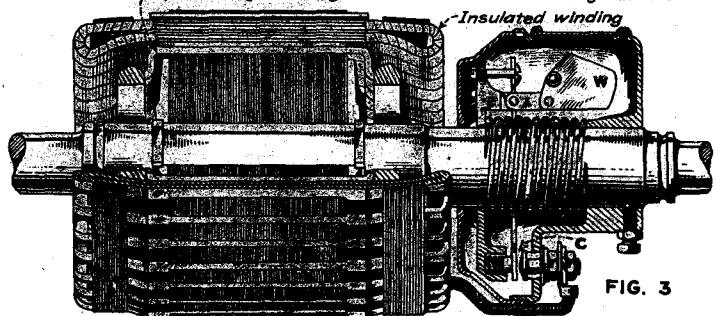

Fig. 1—Rotor for a wound-rotor or slip-ring motor. Fig. 2—Diagram of wound-rotor motor and its starting resistance. Fig. 3—Combination of a squirrel-cage and a coil winding on rotor, for automatic starting.



Synchronous Motors

How They Operate

Fig. 2 shows the rotor and stator assembly of a synchronous motor. When the stator winding is connected to a polyphase alternating-current source, it produces a rotating magnetic field as in an induction motor. When the rotor field coils are connected to direct current, their *N* and *S* field poles lock into step with *S* and *N* poles of the rotating magnetic field and both rotate at the same speed or in synchronism. This speed is fixed by line frequency and number of rotor poles.

Synchronous motors are designed for two standard full-load power factors: unity and 80% leading. Unity-power-factor motors, at full load and normal field current, have 100% power factor. At less than full load, their power factor is less than unity leading, but can be regulated by adjusting the field current.

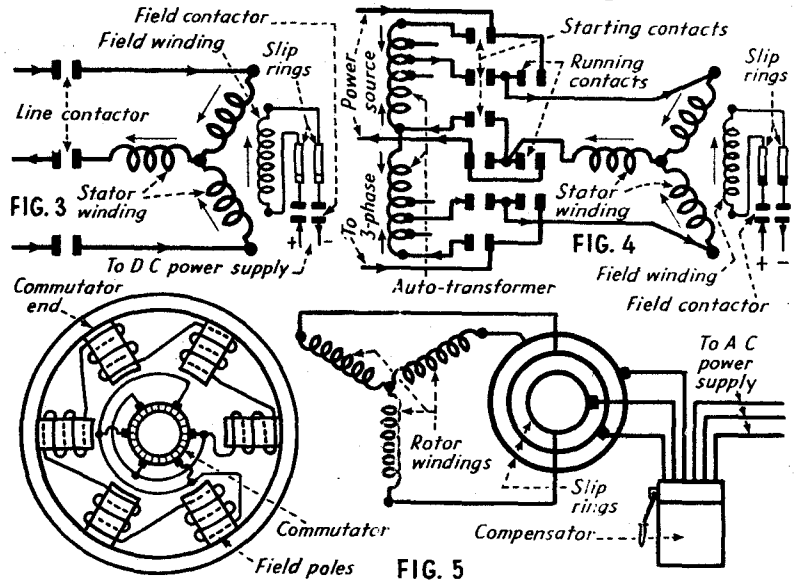
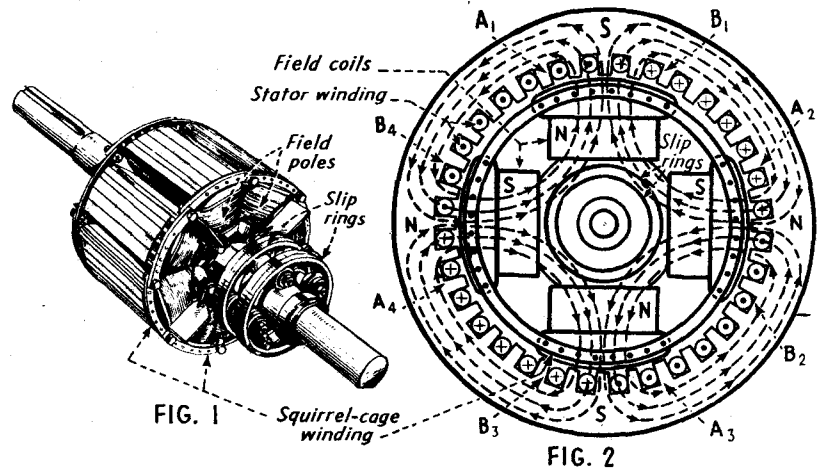

Fig. 1—Synchronous-motor rotor. Fig. 2—Diagram of synchronous-motor stator and rotor assembly. Fig. 3—Diagram of synchronous-motor connections for full-voltage starting. Fig. 4—Diagram of connections for reduced-voltage starting. Fig. 5—Diagrams of stator and rotor connections for self-synchronizing motor

TABLE II—HORSEPOWER AND SYNCHRONOUS-SPEED RATINGS OF GENERAL-PURPOSE INDUCTION MOTORS FOR DIRECT CONNECTION

Cycles	60	60	60	60	25	25
Hp	Rpm	Rpm	Rpm	Rpm	Rpm	Rpm
25	3,600					
30	3,600					
40	3,600					
50	3,600	1,800			1,500	
60	3,600	1,800			1,500	
75	3,600	1,800			1,500	
100	3,600	1,800	1,200		1,500	
125	3,600	1,800	1,200		1,500	
150		1,800	1,200	900	1,500	
200		1,800	1,200	900	1,500	750

ALTERNATING CURRENT DEPARTMENT

THE SYNCHRONOUS MOTOR

THE SYNCHRONOUS MOTOR is so named because the ROTOR revolves at the same speed as the REVOLVING MAGNETIC FIELD of the stator.

THREE WINDINGS ARE USED in this machine:

1. THE A.C. STATOR or armature winding, which produces a revolving magnetic field when polyphase A.C. is applied to it.
2. THE D.C. FIELD or rotor winding, which produces a fixed polarity. This winding must be excited from an outside source of D.C.
3. THE DAMPER or squirrel cage winding which consists of a few large copper bars imbedded in the D.C. field pole faces and shorted together by end rings. This winding serves 2 purposes: (a) It permits the motor to start as an induction tends to prevent hunting.

HUNTING is a periodical variation in the speed of the rotor with regard to the revolving magnetic field of the stator. It is caused by: (a) a sudden change in mechanical load. (b) a sudden change in A.C. line voltage. (c) a sudden change in D.C. field excitation. (d) hunting on the same system of other rotating electrical equipment.

THE FIELD DISCHARGE SWITCH and the field discharge resistor are arranged to protect the D.C. field from high transformer voltages induced by the stator field during the starting period, and also from high self-induced voltages generated by collapsing D.C. field flux when the field is disconnected from the source of excitation. The discharge resistor and switch form a closed circuit on the field when the switch is placed in the discharge position, and this greatly reduces the danger to the field insulation.

ADVANTAGES OF THE SYNCHRONOUS MOTOR: 1. Constant speed. 2. Variable power factor. The power factor may be varied by controlling the excitation current of of D.C. field. The P.F. will be UNITY of 100% at NORMAL excitation, LAGGING at UNDER excitation, LEADING at OVER excitation.

THE MOTOR WILL CORRECT POWER FACTOR because when the D.C. field is over excited the A.C. stator will draw a LEADING current which will neutralize a LAGGING current drawn by inductive apparatus connected to the same system. It will carry a mechanical load and correct P.F. of the system at the same time providing the full load current rating of the machine is not exceeded.

DISADVANTAGES OF SYNCHRONOUS MOTOR: Greater cost per H.P., low starting torque, subject to hunting, requires outside source of excitation, more auxiliary apparatus for control and indication, more intelligent handling, and may require some form of clutch to connect the load to it.

APPLICATIONS: Driving compressors for air conditioning and refrigeration, also for compressed air. Driving textile mill looms, cement grinding and rubber processing machines, paper pulp grinders, also M.G. sets, frequency changers, or in general any load of 25 H.P. or more not requiring heavy starting torque and which may be operated at a constant speed.

ROTATION may be reversed by changing any 2 of the 3 stator leads. The D.C. field polarity does not determine the direction of rotation.

PROCEDURE FOR STARTING THE MOTOR:

1. Reduce the exciter voltage to a minimum. (Turn field rheostat to right)
2. Place the field discharge switch in the discharge position.
3. Apply low voltage A.C. to the stator and allow motor to accelerate to almost full speed. (Watch AM. to note when starting current is reduced to a minimum.)
4. Close the D.C. field switch to apply excitation current to the field.
5. Apply full voltage to the stator winding.
6. Adjust D.C. field excitation to obtain desired power factor.

PROCEDURE FOR STOPPING THE MOTOR: Remove the mechanical load if possible, then reduce field excitation and finally disconnect the stator from the A.C. supply.

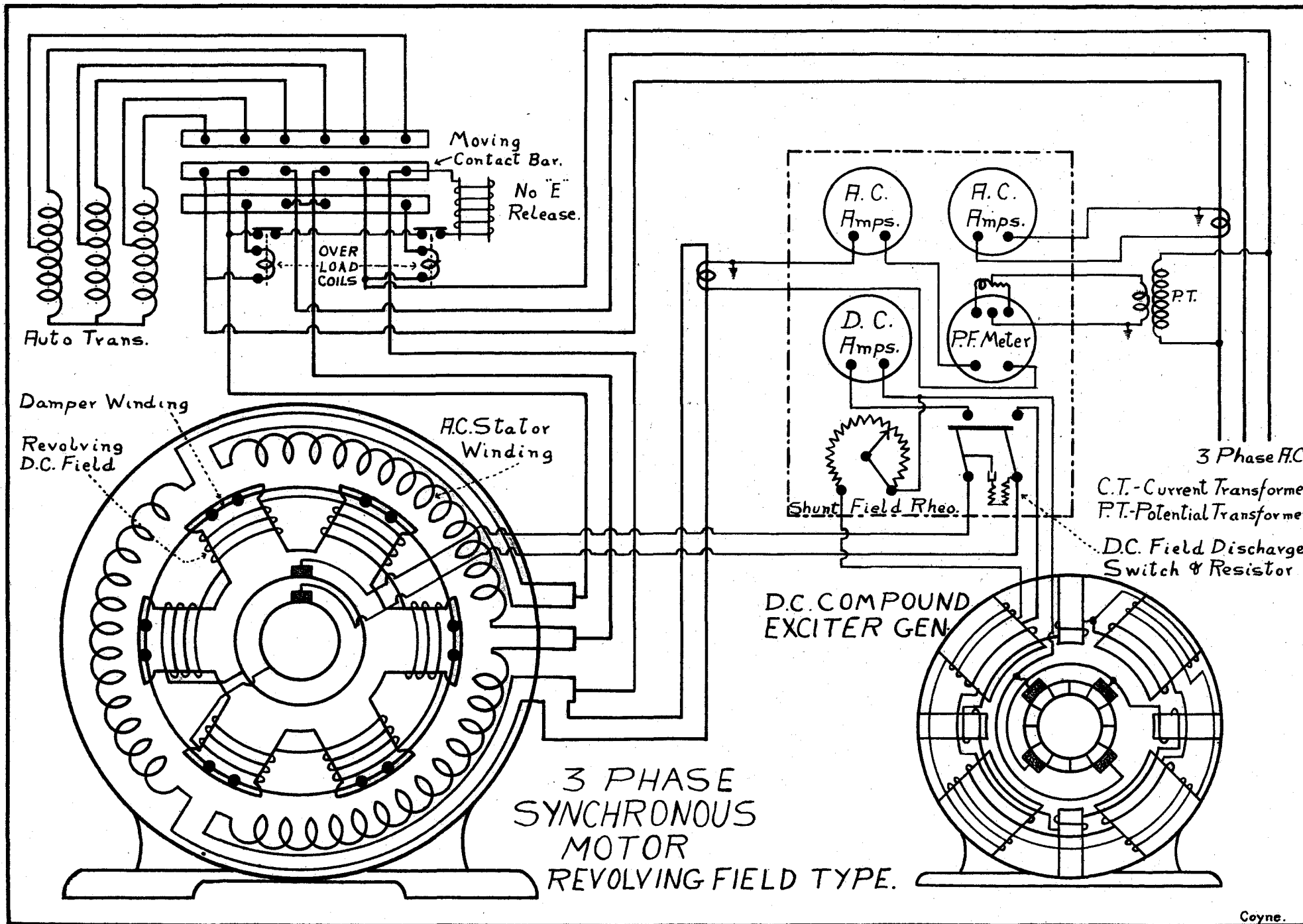

Rating Chart for General Electric Synchronous Motors

General Electric manufactures standard and special synchronous motors covering a wide range of ratings. This chart gives a general idea of the appearance of

some of these many motors that can be built. A G-E synchronous-motor specialist will gladly assist in the selection of the drive best suited to your requirements.

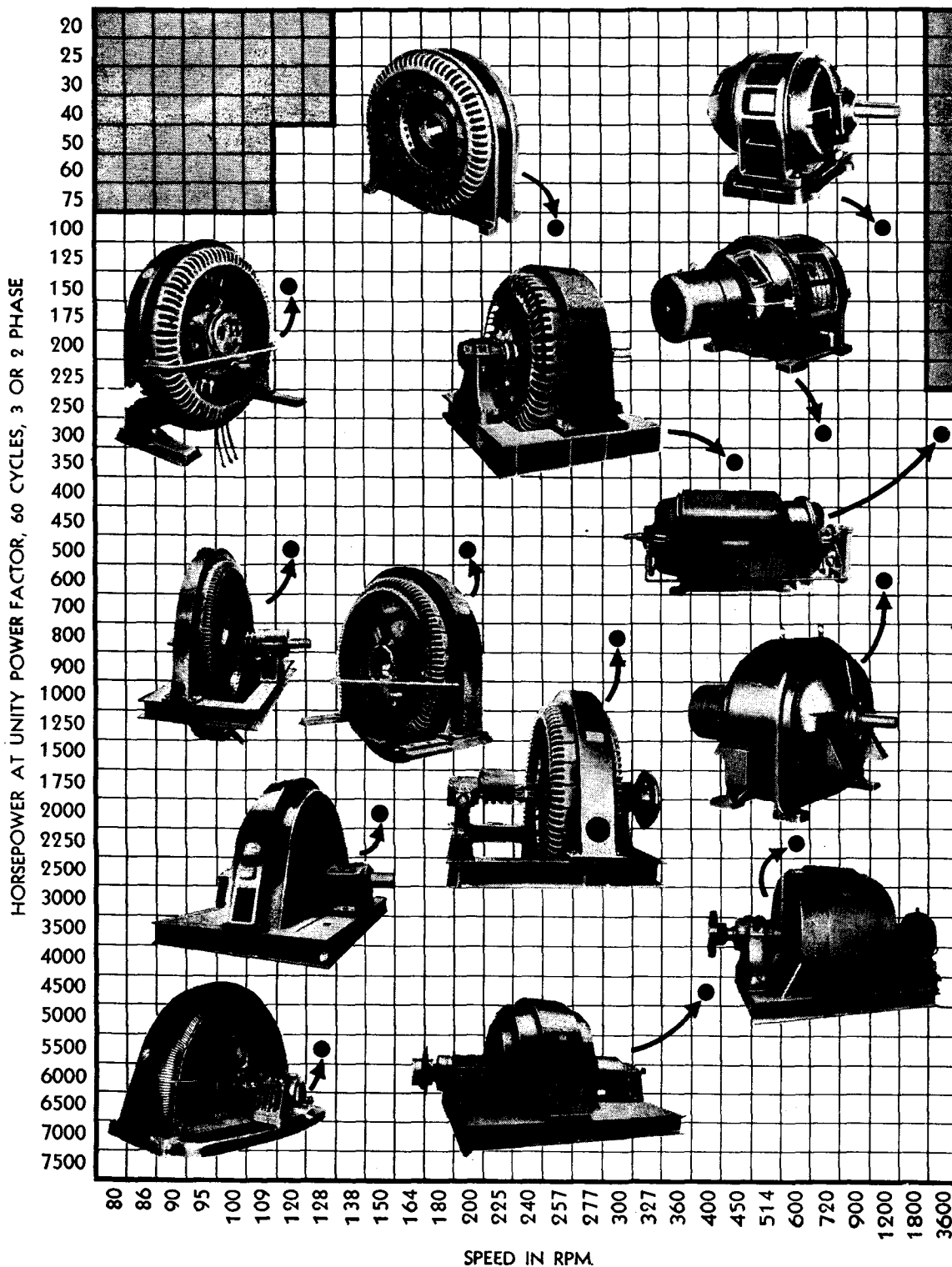

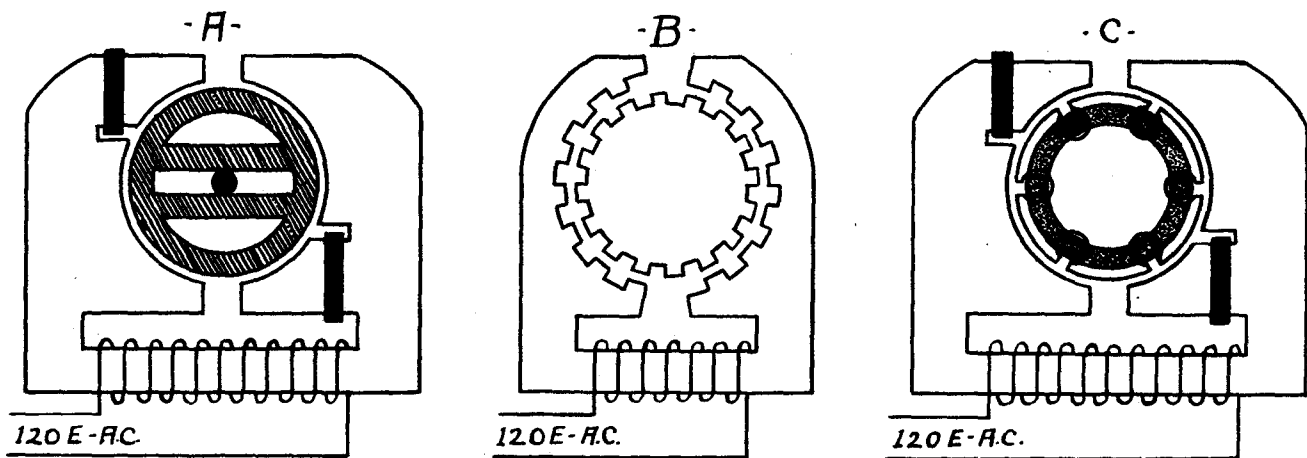

(A) Due to their constant speed characteristics, small synchronous motors are widely used in stroboscopes, mechanical rectifiers, electric clocks, recording devices, timing relays, demand meters, etc. These small motors operate similarly to the large power types except that the small units are not separately excited, the poles on the rotor being produced by magnetic induction from the stator. Turning at synchronous speed, the rotor is polarized and is in the position shown when the stator current is maximum. As the current diminishes, momentum carries the rotor to the vertical position just as the main poles reverse and, as the hard steel rotor still retains its poles, it is again attracted to the horizontal position and rotation continues. Shading coils are employed to make the unit self starting. Speed is determined by frequency; if frequency is constant, speed will not vary.

(B) SYNSYNCHRONOUS CLOCK MOTOR - Consists of a 2 pole stator and an iron rotor with 16 or more salient poles. The motor is not self starting, but when operating at synchronous speed, 2 diametrically opposite poles are attracted to the field poles as the flux of the field is increasing. Because of the inertia of the rotor, it continues to rotate while the flux is decreasing and passing through zero. The next pair of poles is then attracted by the field flux as it increases in the opposite direction. Although the stator has only 2 poles, the speed of the motor is the same as that of a motor having the same number of stator and rotor poles. EXAMPLE - At 60 cycles the speed is 450 R.P.M., corresponding to the 16 rotor poles. Because the rotor speed is much less than that corresponding to the 2 stator poles, the motor is said to operate at SUBSYNCHRONOUS speed.

(C) SELF-STARTING INDUCTION-REACTION SYNSYNCHRONOUS MOTOR - This motor is a 2 pole, single phase, combination induction and synchronous motor with a shaded pole field and a squirrel cage rotor. In this particular motor there are 6 rotor slots, so proportioned that they produce 6 salient poles on the rotor which give the synchronous (or reaction) motor effect. AT STARTING; the induction motor torque must be sufficient to overcome the tendency of the salient poles of the rotor to lock in with the stator poles, The motor operates as any induction motor, the rotor tending to accelerate to nearly synchronous speed. EXAMPLE - At 60 cycles, the induction motor torque tends to accelerate the rotor nearly to the 2 pole synchronous speed of 3600 R.P.M. The motor is so proportioned that at 1200 R.P.M., the 6 pole synchronous speed, the reaction torque due to the pulsating stator pole flux reacting with the 6 rotor poles, predominates over the induction motor torque developed at that speed. The rotor, therefore, locks in with the stator poles and runs synchronously at 1200 R.P.M. At its operating sybsynchronous speed, the motor develops simultaneously induction motor and synchronous motor torque. This type is used chiefly with timing devices.

SINGLE PHASE A.C. MOTORS.

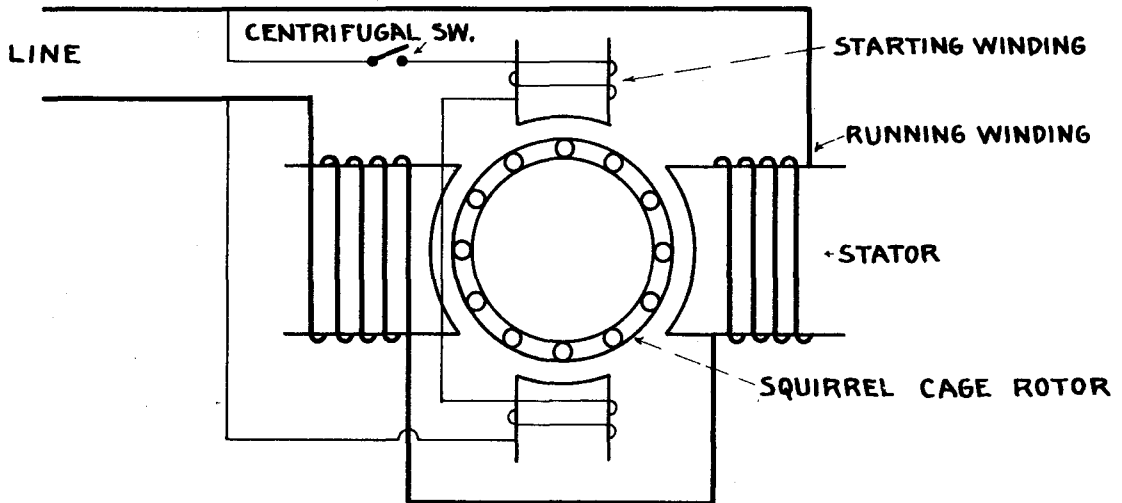

SINGLE PHASE SPLIT PHASE MOTOR.

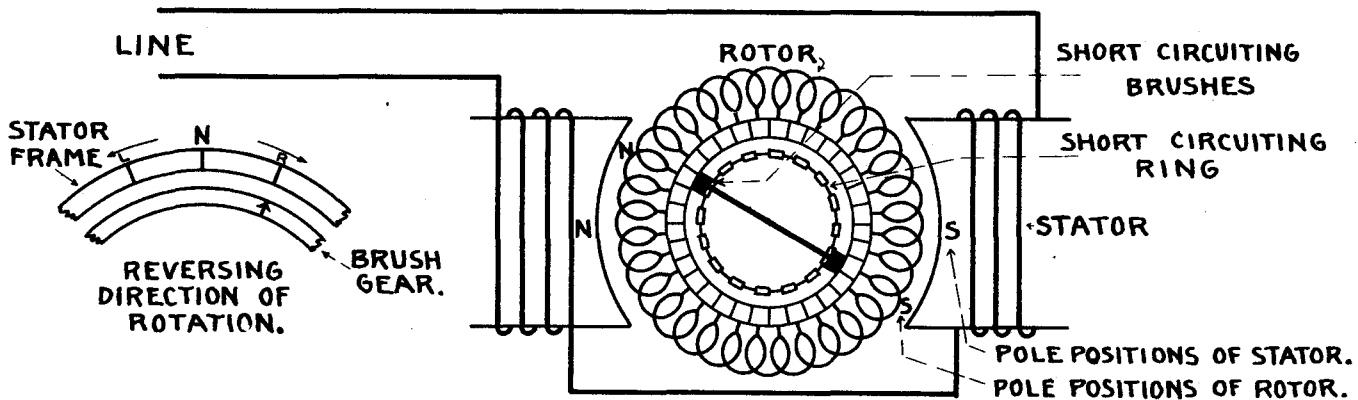

REPULSION START INDUCTION MOTOR.

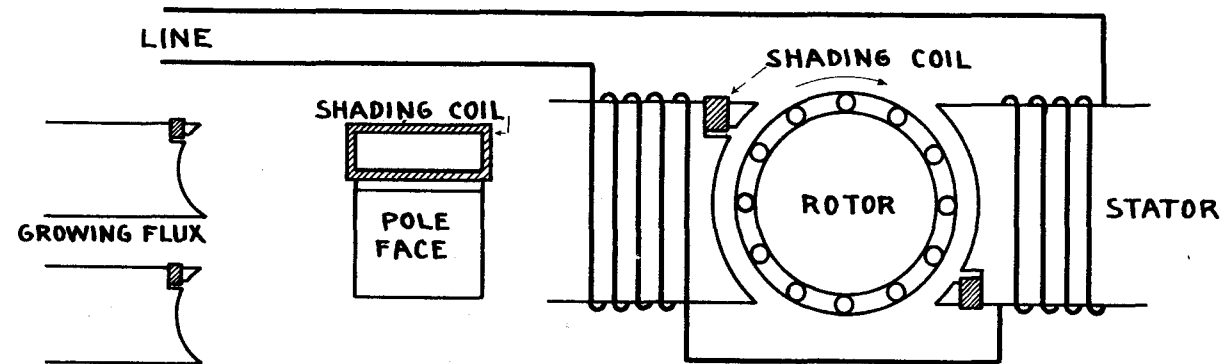

SHADED POLE INDUCTION MOTOR.

What Is a Split-phase Motor?

A SPLIT-PHASE motor is a single-phase motor that obtains its starting torque from two stator windings of different impedance values which in effect convert the single-phase current to an equivalent two-phase current. The few and simple parts of this motor are shown schematically at the right.

The arrangement and operation of these parts are shown below. The windings are located in different sectors around the stator, and the starting winding is in series with the starting switch. A switch-actuating mechanism is mounted on the rotor and is set to open the switch and open-circuit the starting winding when the motor reaches a predetermined speed.

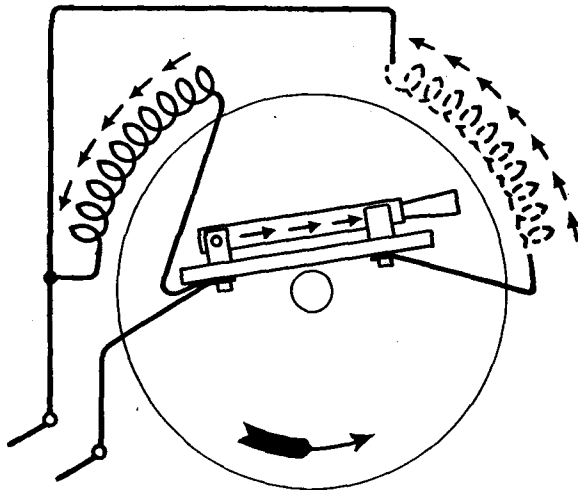
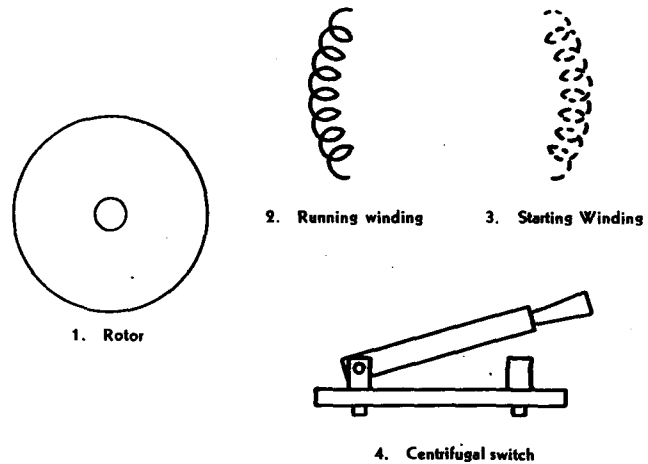

The phase displacement of the currents in the starting and running windings, together with their physical displacement on the stator, produces a rotating magnetic field that starts the rotor revolving

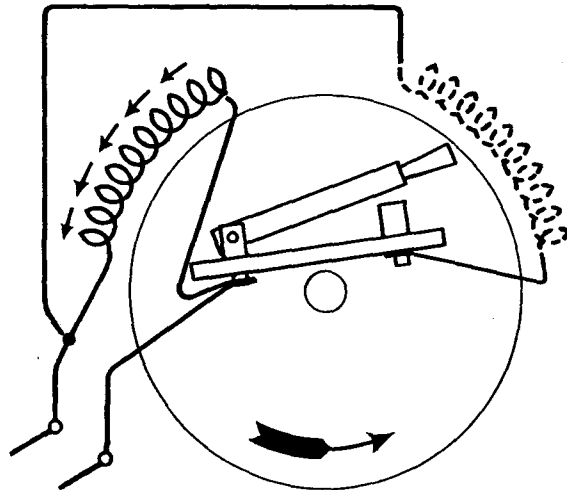

When the rotor reaches a predetermined speed, the centrifugal switch opens the starting winding. Current flows only in the running winding, and the motor operates the same as an ordinary induction motor.

Why Split-phase Motors Are Used

Split-phase motors are admirably suited to applications that require an inexpensive, reliable motor with moderate torque. Inherently simple in construction and operation, the split-phase motor will give many years of satisfactory operation without attention except occasional oiling. Split-phase

motors do not interfere with radio reception—they have no brushes or commutators. Split-phase motors have become the accepted drive for domestic washing machines, ironers, fans, and similar devices where long periods of operation without attention are so desirable.

SINGLE - PHASE SPLIT-PHASE INDUCTION MOTOR

Job No.1-A

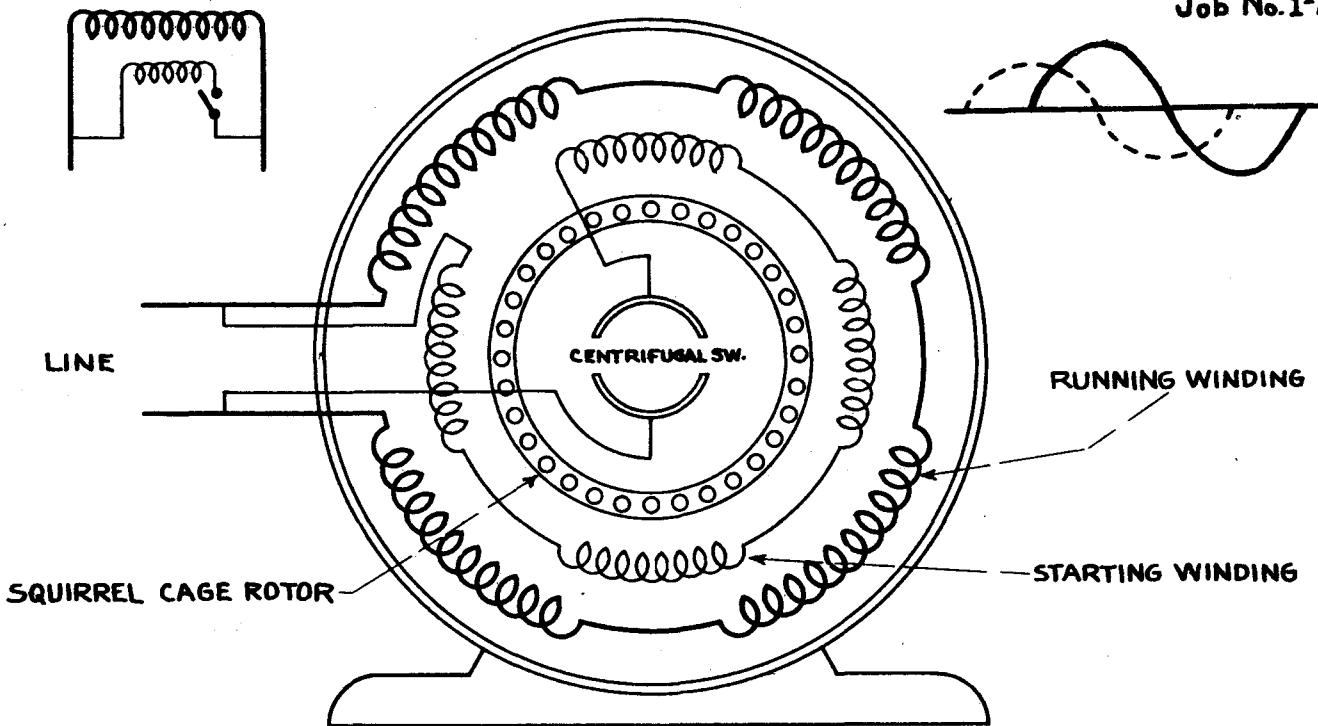

OPERATION

To be self-starting, the stator winding of a squirrel-cage induction motor must be capable of setting up a rotating magnetic field. Since such a field cannot be produced by a single winding energized by a single-phase current, some method of splitting this current into two currents approximately 90 degrees out of phase with with other must be provided. This is accomplished by having the single-phase current flow through two parallel paths having different electrical characteristics. One path, being highly inductive, causes the current flowing through it to lag almost 90 degrees behind the current through the other path. By this method, a revolving magnetic field is produced with single-phase current. Starting as a two-phase machine, this motor accelerates to about 75% of normal full load speed when a centrifugally-operated switch disconnects the starting winding and converts the unit to a straight single-phase type.

CHARACTERISTICS

This motor will develop from 1 to 1.5 times normal full load torque, and will draw as high as 9 times normal full load current when full line voltage is applied at starting. The speed variation from no load to full load will not exceed 5% of the normal full load speed. For complete data on current, torque, etc., see curves given below.

APPLICATION

Washing machines, ventilating fans, sign flashers, bottling machinery, oil burners, dairy machinery, garage equipment, stokers, coffee mills, shoe machinery, exercisers, dish washers, oil pumps, etc. In general, this motor - which is usually built in fraction h.p. sizes only - may be used for any small load that does not require a high starting torque and can be operated at constant speed.

TROUBLES

Centrifugal switch, starting winding, bearings, loose connections, oil-soaked insulation, opens, shorts and grounds, improper

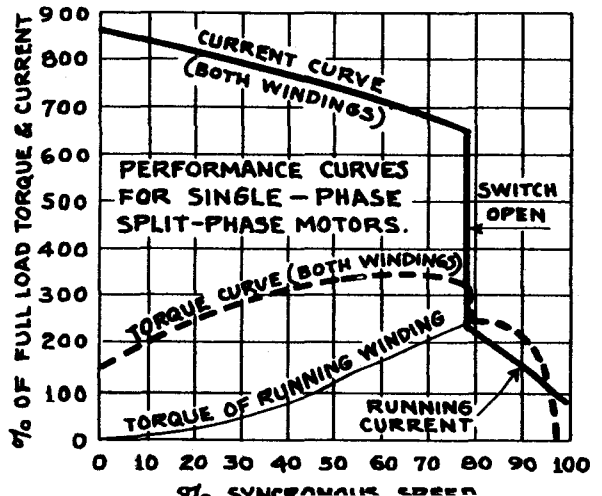

SPIRAL TYPE WINDING USED IN SINGLE PHASE SPLIT PHASE MOTORS

SLOTS = 36 POLES = 4

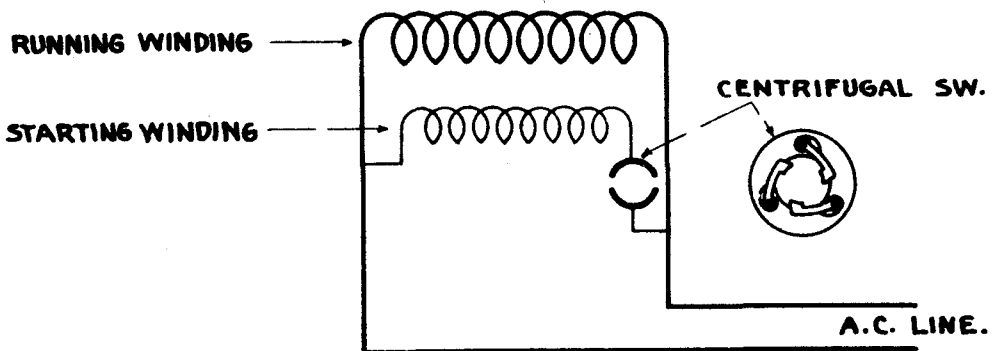
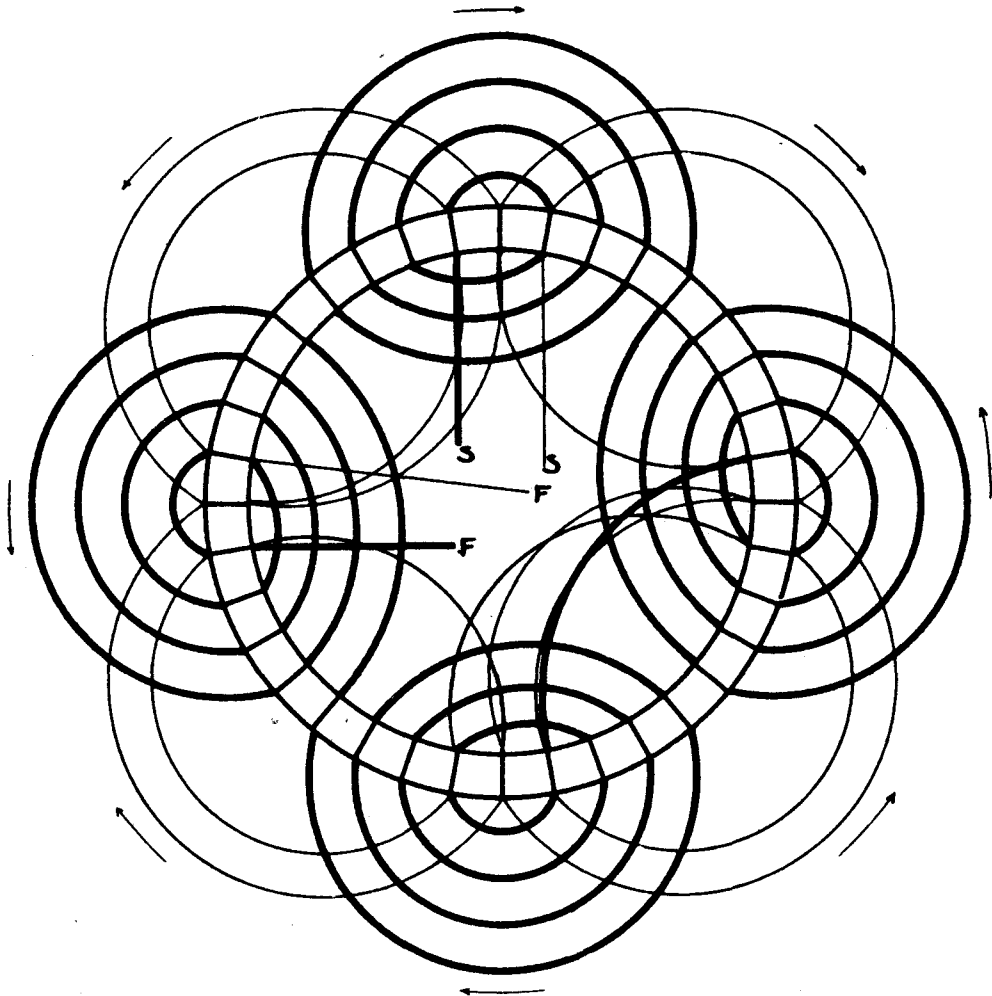

REVISIONS		MATERIAL	PAT. MLD. DIE	V-5837029			
1	12-8-39 R. Kirby			FD-35440	EXTERNAL DIAGRAM FIRST MADE FOR <i>KH MOTORS OVERLOAD</i> FIRST CALLED FOR ON <i>SKH45AB1416AX</i>		
2	DEC-26-39 R. Kirby			FEB. 15, 1940			
3	JUNE-15-40 G. Howen			R. Kirby			
DRAWN BY <i>R. Kirby</i> INSPECTED <i>G. Howen</i>							

USE ONLY WHEN LEADS ARE BROUGHT OUT OPP END FROM TERMINAL BOARD, UNLESS LEADS ARE ANCHORED EXTERNALLY. SEE V-5837052.

**NOT REVERSIBLE
C.W. ROTATION**

PRINTS TO

B 8

B44:3

B45

B74:2

B84:2

B88:3

B106

B112

11-24-43

GEJ TAG 530

THIRD ANGLE PROJECTION

GENERAL ELECTRIC FORT WAYNE WORKS

V-5837029

FF-68 Im 8-10-37

FILE D-75

REVISIONS		MATERIAL	PAT. MLD. DIE	V-5870447		
1	DEC. 24 '44 R. Kirby			EXTERNAL DIAGRAM FIRST MADE FOR <i>KH POLE CHANGING</i> FIRST CALLED FOR ON <i>SKH47AB1110X</i>		
DRAWN BY <i>R. Kirby</i> INSPECTED <i>G. Howen</i>						

GEJ TAG 1076

C.C.W. ROTATION AS SHOWN; FOR C.W. ROTATION INTERCHANGE RED & GREEN LEADS ON TOP OF TERMINAL BOARD

PRINTS TO

B 8

B44:3

B60:2

B74:2

B106

B80:3

1244

B102

B128:9

THIRD ANGLE PROJECTION

GENERAL ELECTRIC FORT WAYNE WORKS

V-5870447

FF-68 Im 12-22-37

FILE D-75

REVISIONS

MATERIAL

PAT. MLD. DIE

V-5837494

DRAWN BY *R. Kirby*
INSPECTED *W. Hahn*

EXTERNAL DIAGRAM
FIRST MADE FOR KH MOTORS - OVERLOAD

FIRST CALLED FOR ON SKH498868BY

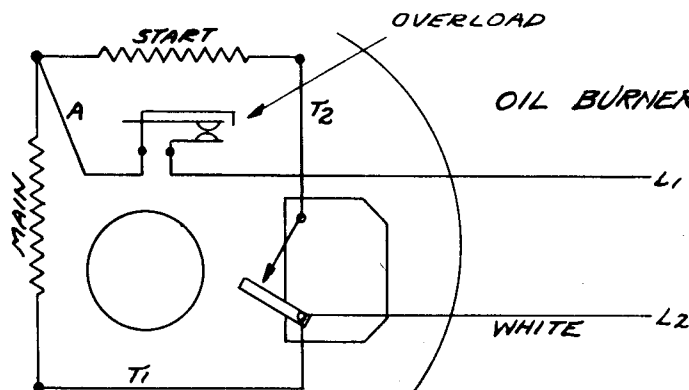

PRINTS TO

- BB
- 844.3
- 874.2
- 884.2
- 888.3
- B106

FEJ
ZAG
530

FILE
D-75

THIRD ANGLE PROJECTION

V

GENERAL  ELECTRIC FORT WAYNE WORKS
V-5837494

FF-68 Im 12-22-37



ENGINEERING INFORMATION

SPLIT PHASE INDUCTION MOTORS

TYPE SP; 110 OR 220 VOLTS; REVERSIBLE

Location of Terminals	Frames	Internal Connection Diagrams (Counter Clockwise Rotation)	Label (Attached To Cover Over Terminals)
-----------------------	--------	---	--

WITHOUT OVERLOAD PROTECTION

<p>In Front Bracket</p>	<p>63G, 65G, 67G, 65L, 67L</p>	<p>C-12184-A</p>	<p>CENTURY ELECTRIC CO. 1120 ST. LOUIS, MO.</p>
<p>In Frame</p>	<p>43, 45, 53, 71, 73</p>	<p>C-12183-A</p>	<p>CENTURY ELECTRIC CO. 1124 ST. LOUIS, MO.</p>

WITH OVERLOAD PROTECTION

<p>In Front Bracket</p>	<p>63G, 65G, 67G, 65L, 67L</p>	<p>C-12184-B</p>	<p>CENTURY ELECTRIC CO. 1122 ST. LOUIS, MO.</p>
<p>In Frame</p>	<p>53, 71, 73</p>	<p>C-12183-B</p>	<p>CENTURY ELECTRIC CO. 1128 ST. LOUIS, MO.</p>

What Is a Capacitor-motor?

A CAPACITOR-MOTOR is a single-phase motor that has a capacitor (condenser) connected in one of its windings. The few and simple parts of this motor are shown schematically at the right.

The arrangement of these parts is shown below. The two windings are in different sectors around the stator. The starting winding, the capacitor, and the centrifugal switch are connected in series. The centrifugal switch is mounted on the rotor and is set to open at a predetermined speed.

When power is applied, current flows in the direction shown by the red lines and arrows.

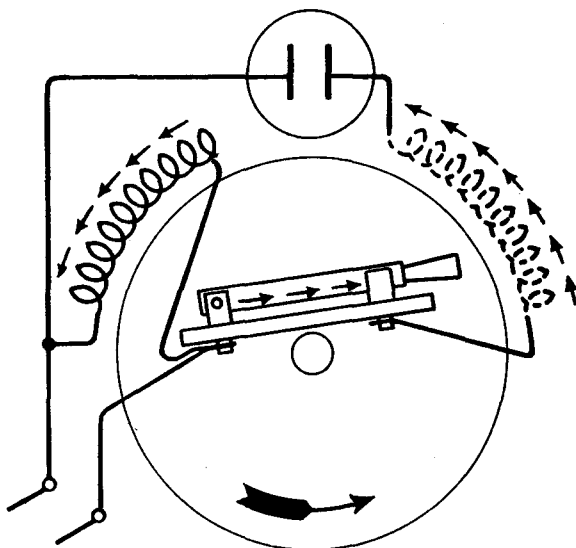
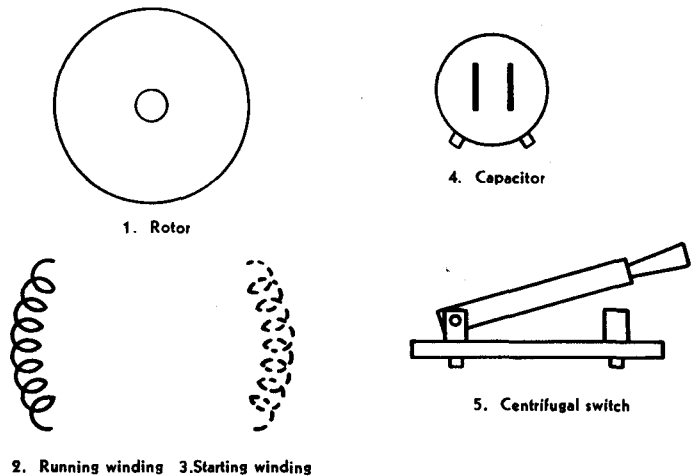

The phase displacement, set up by the capacitor, of the currents in the starting and running windings, together with their physical displacement on the stator, produces a rotating magnetic field that starts the rotor revolving

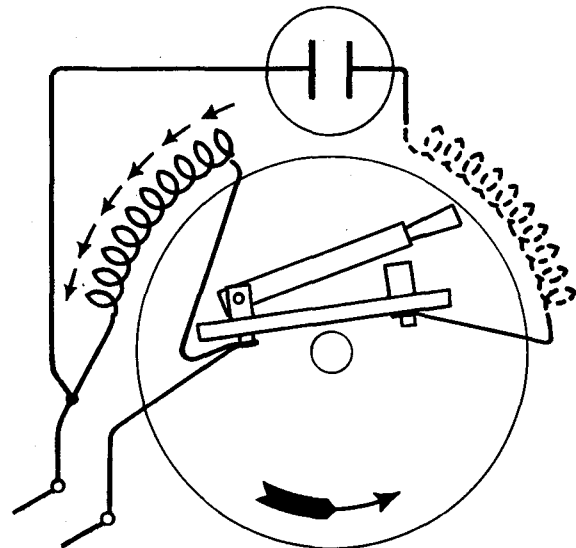

When the rotor reaches a predetermined speed, the centrifugal switch opens the starting-winding circuit. Current flows only in the running winding, and the motor operates the same as an ordinary induction motor

Why Capacitor-motors Are Used

Some machines require more torque (effort) to start them than the resistance split-phase motor can provide. The capacitor-motor is designed for these applications and differs from the resistance split-phase motor chiefly in that it has a capacitor connected in series with the starting winding.

The use of the capacitor gives the motor a high starting torque with low starting current without

sacrifice of the advantages of the resistance split-phase motor. Occasional oiling depending upon conditions of motor service, is the only attention required. Motor operation does not interfere with radio reception. Capacitor-motors have become the accepted drive for domestic refrigerators, and for stokers and similar devices in which long life, minimum servicing, and quiet operation are of paramount importance.

CAPACITOR MOTOR

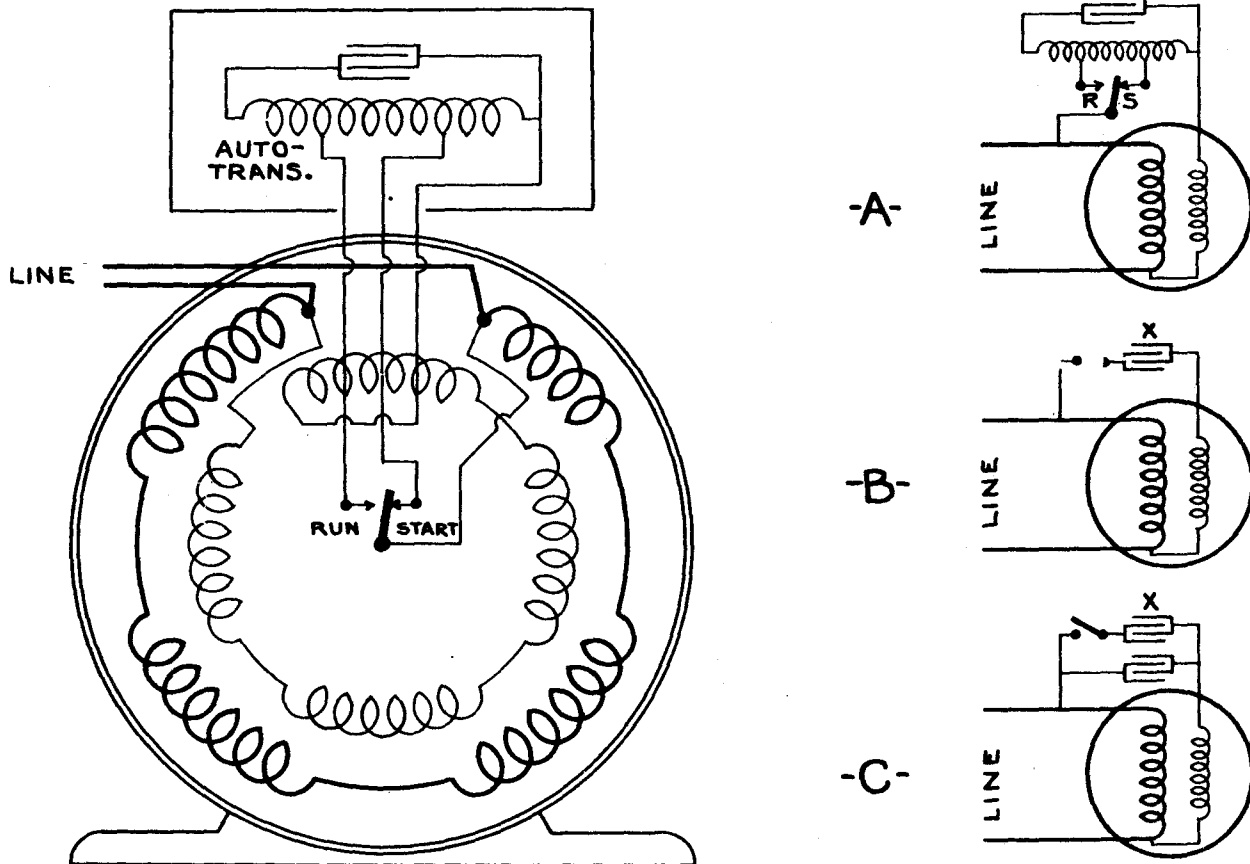

The above motor is a split-phase type, the phase-splitting action being obtained by the insertion of a condenser in series with the starting winding. This motor starts and runs as a two-phase motor. The auto transformer connected across the condenser applies a comparatively high voltage to the condenser, thereby giving a higher capacity effect, and making possible the use of a smaller condenser than would otherwise be necessary.

During starting the centrifugally-operated switch is in the "start" position. This applies about 500 volts to the condenser, giving a high capacity effect and producing a comparatively high starting torque. When the motor has reached about 75% of normal full speed, the switch is thrown over to the "run" position, applying about 350 volts to the condenser, thereby reducing its capacity effect to a value which will maintain a high power factor during operation.

This motor will develop approximately 4 times normal full load torque with 7 times normal full load current. Compared with the repulsion-start-induction motor, the capacitor motor has a lower starting torque and a much higher starting current, about the same full load efficiency and a higher full load power factor. For equal rating, capacitor motors cannot stand as long a starting period as the repulsion type: Capacitor motors are widely used in household refrigeration and may be used where repulsion-start-induction motors are applicable, except where very high starting torque and long starting periods are involved in which case the repulsion-start-induction motor is used.

The small diagrams, A, B and C, on the right are schematic diagrams of capacitor motors. "A" is the circuit for the large diagram, (capacitor start, capacitor run motor) while "B" and "C" represent two other types which do not use an auto transformer. "B" uses a condenser on starting only, while "C" uses two condensers on starting, while only one remains in the circuit when running.

The electrolytic type of condenser is used on condenser-start motors only. This type of condenser must not be left in the circuit for more than 3 or 4 seconds, if condenser breakdown is to be avoided. Condensers marked "X" may be electrolytic, but the others shown must be the metal foil and paper type.

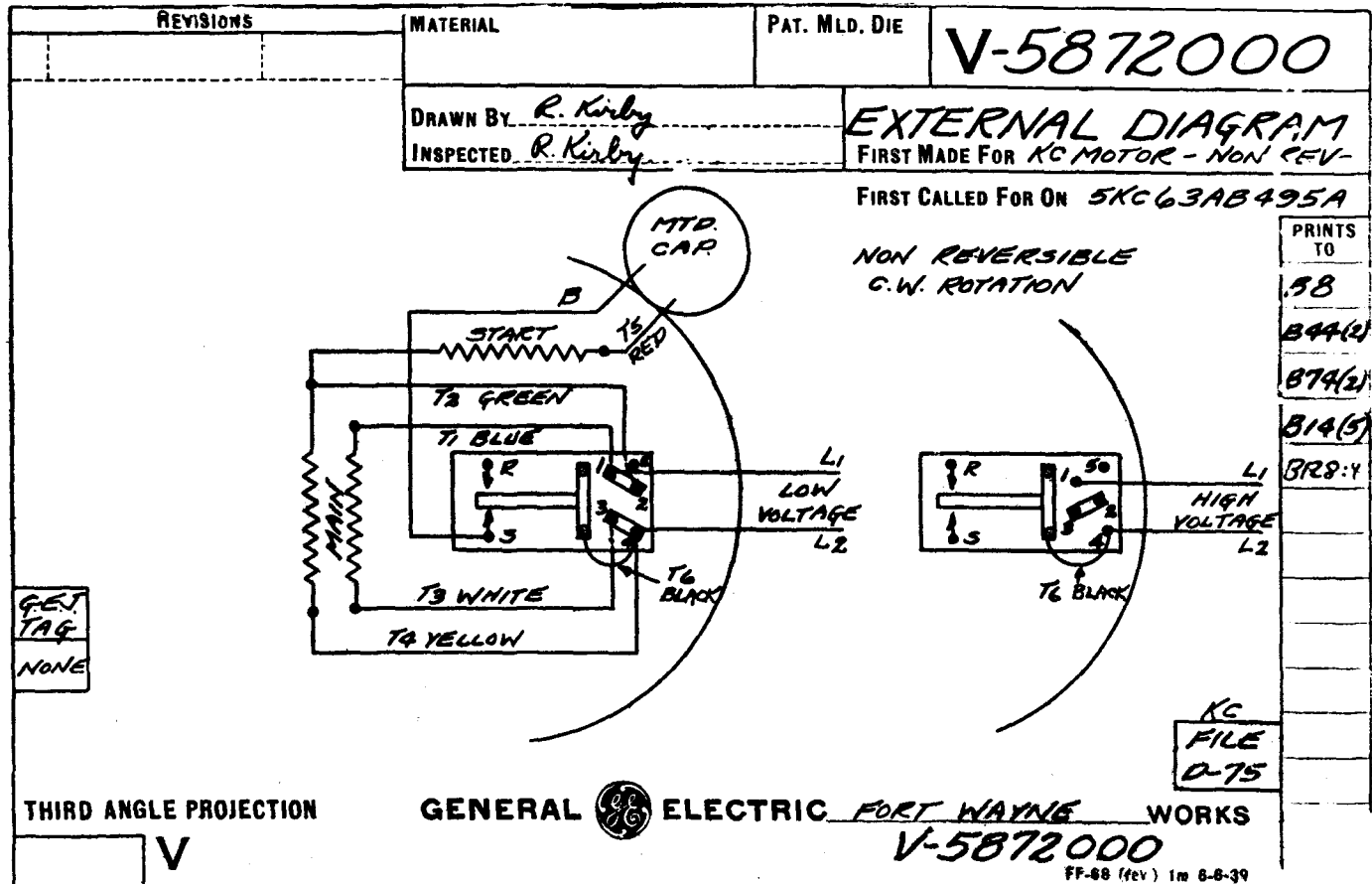
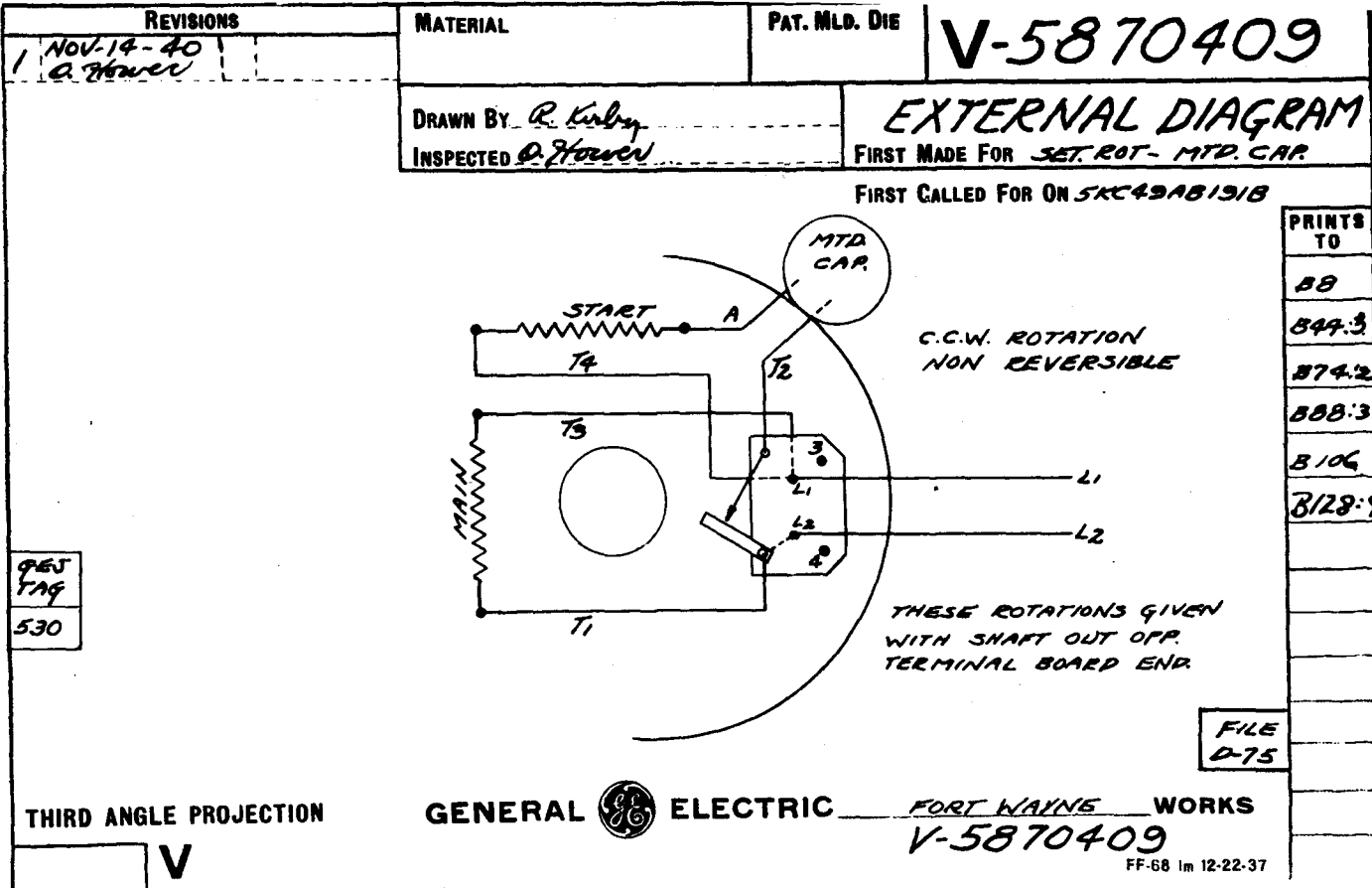

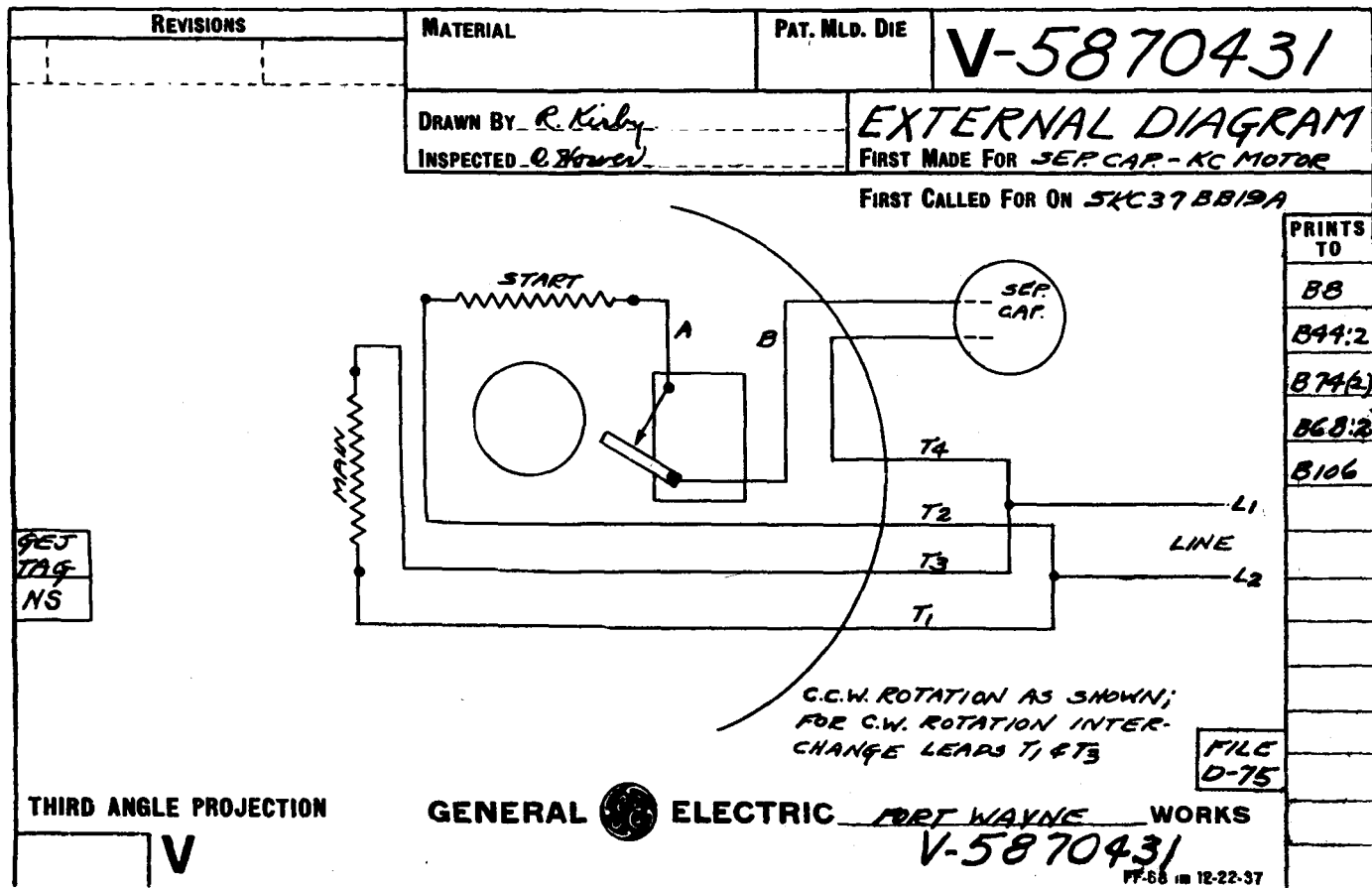
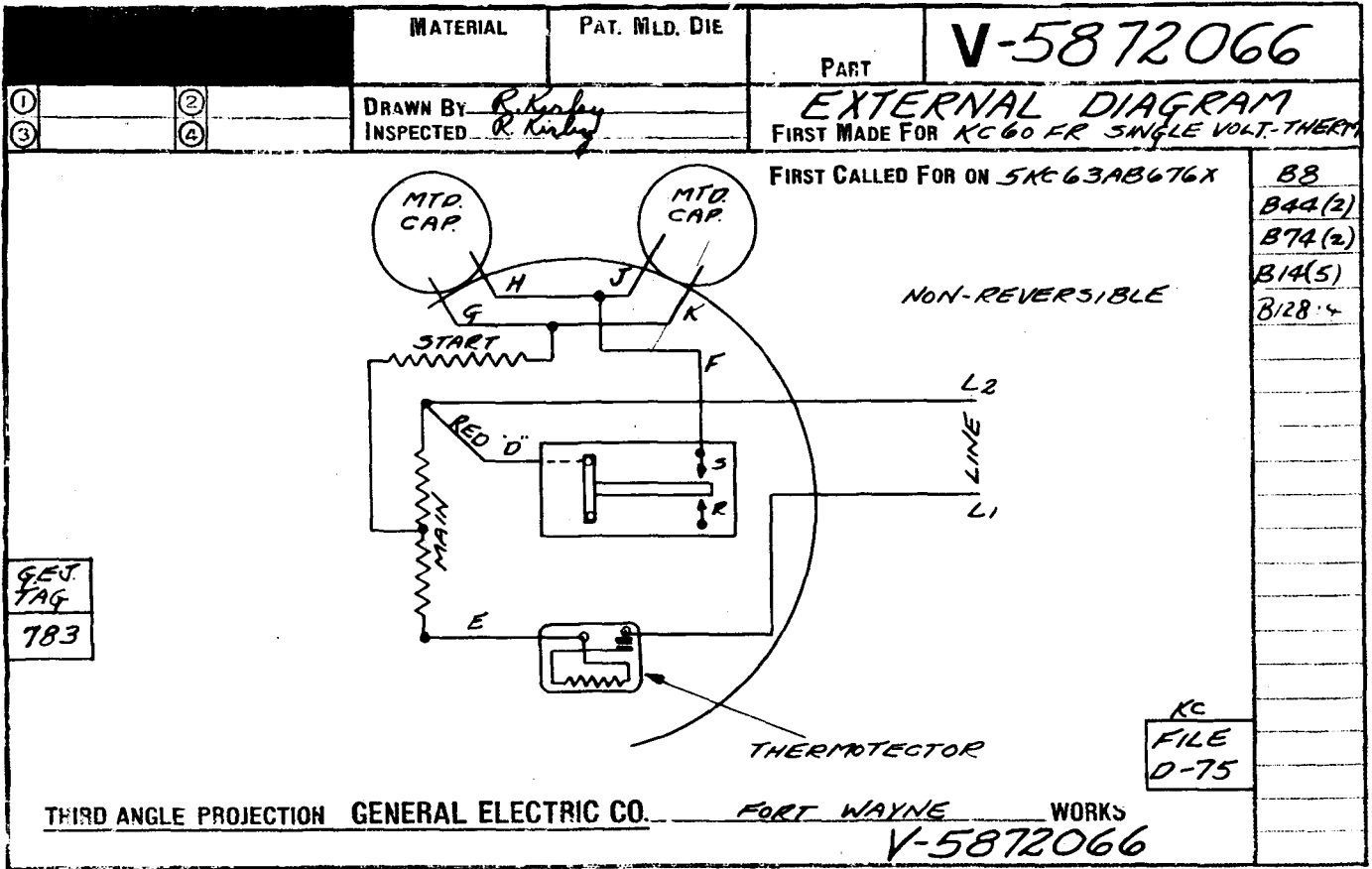

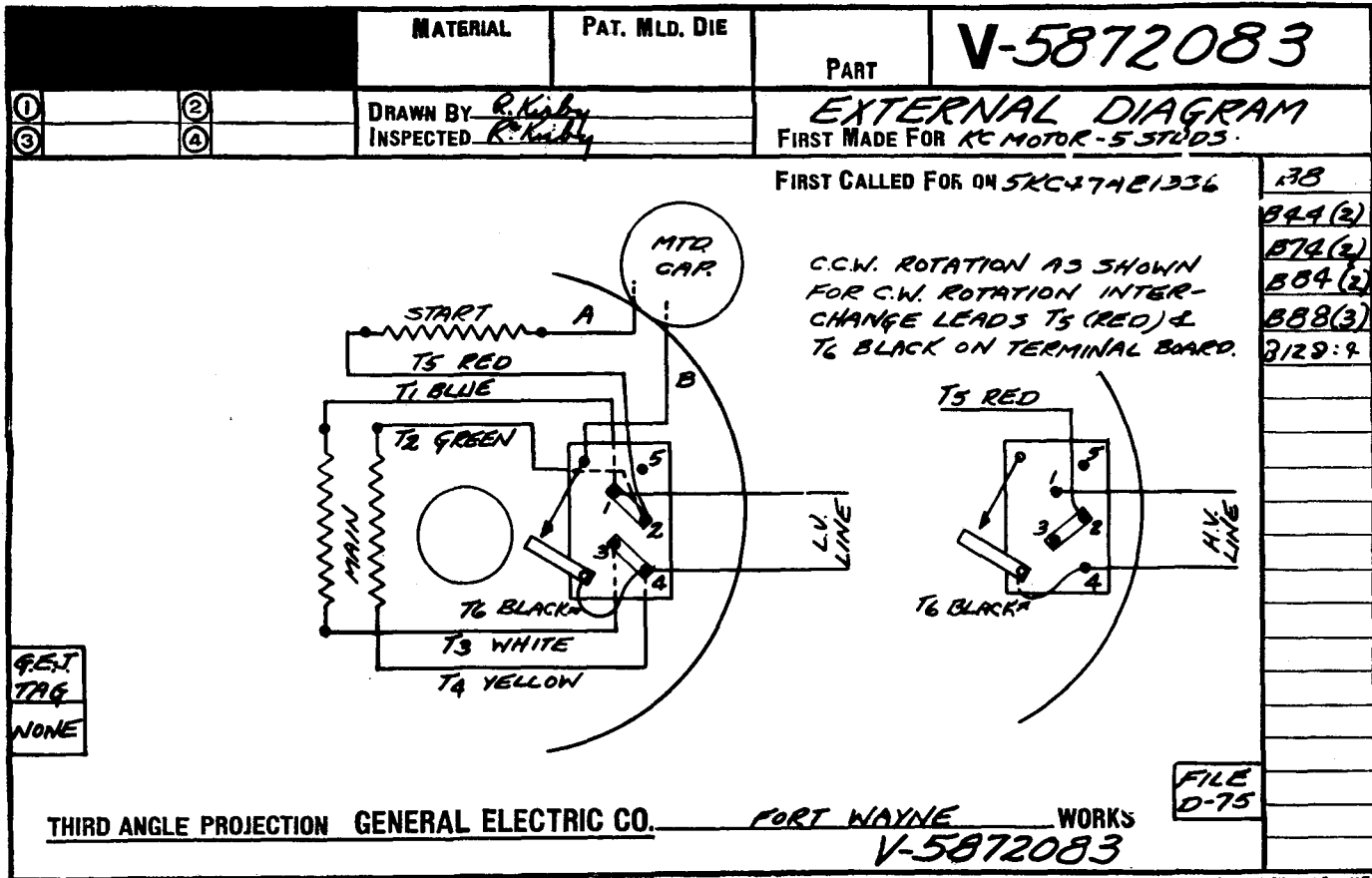

FF-68 10M 10*13-27

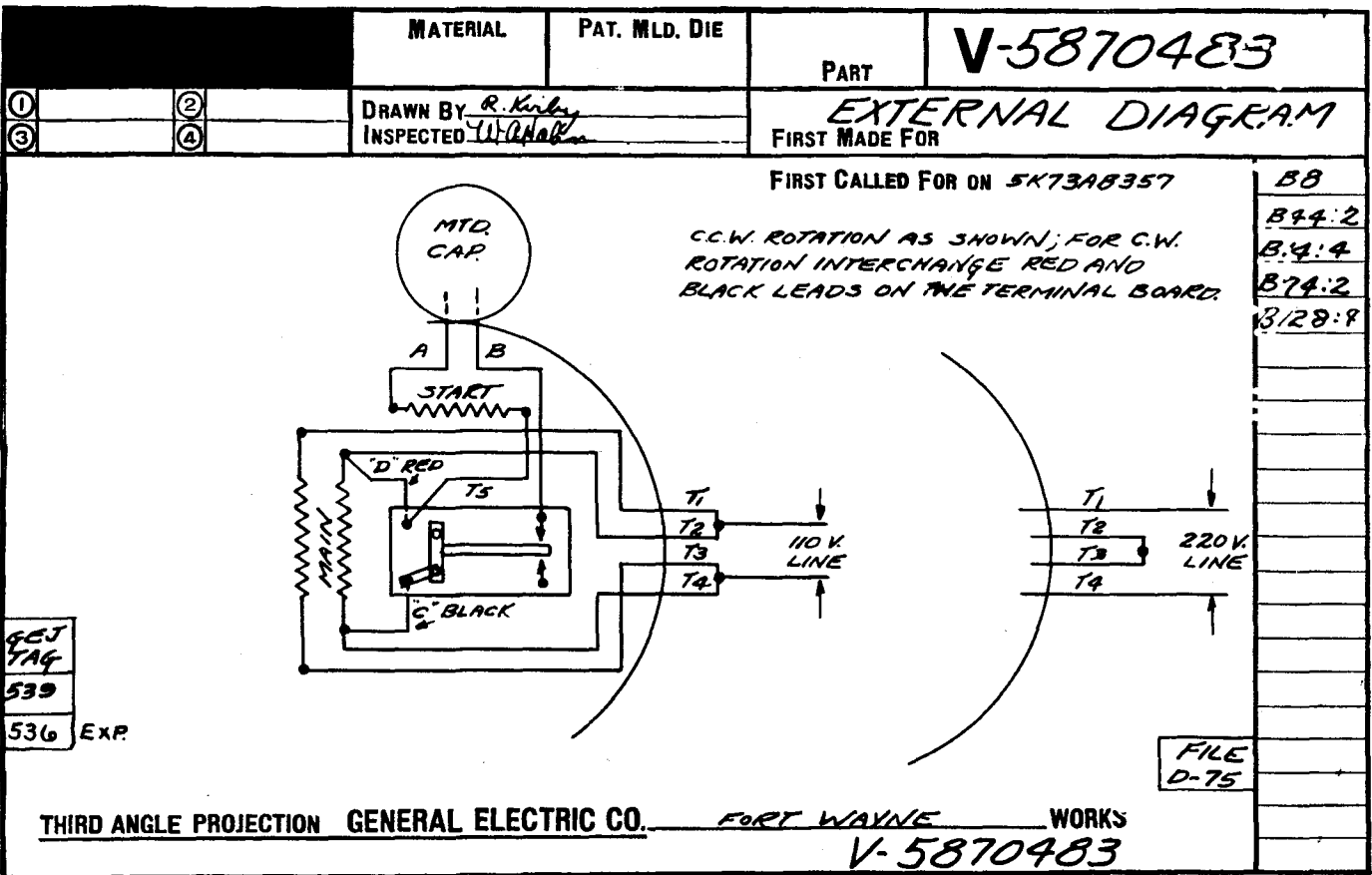

FF-68 10M 10*13-27

REVISIONS	MATERIAL	PAT. MLD. DIE	V-5835194
	DRAWN BY <i>W. A. Hall</i> INSPECTED <i>Marakums</i>	EXTERNAL DIAGRAM FIRST MADE FOR <i>KC MOTOR REV. STP. CAP.</i> FIRST CALLED FOR ON <i>M-W 75696</i>	

FOR C.C.W. ROTATION CONNECT T₁ & T₂ TO ONE SIDE OF LINE AND T₃ TO THE OTHER FOR C.W. ROTATION INTERCHANGE T₁ & T₃

PRINTS TO
B8
B44:2
B45
B14
B74:2

THIRD ANGLE PROJECTION

V

GENERAL ELECTRIC FORT WAYNE WORKS

V-5835194

	MATERIAL	PAT. MLD. DIE	V-5870232
① ② ③	④ ⑤ ⑥	DRAWN BY <i>W. A. Hall</i> INSPECTED <i>W. A. Hall</i>	EXTERNAL DIAGRAM FIRST MADE FOR <i>KC MOTORS - EITHER</i> FIRST CALLED FOR ON <i>5KC77AB40</i>

C.C.W. ROTATION AS SHOWN; FOR C.W. ROTATION INTERCHANGE "E"(RED) AND "F"(BLACK) AT TERMINAL BOARD

B8
B44:2
B14:5
B74:2
B129:4

GEJ-TAG

539

THIRD ANGLE PROJECTION GENERAL ELECTRIC CO. FORT WAYNE WORKS

V-5870232

KC FILE D-75

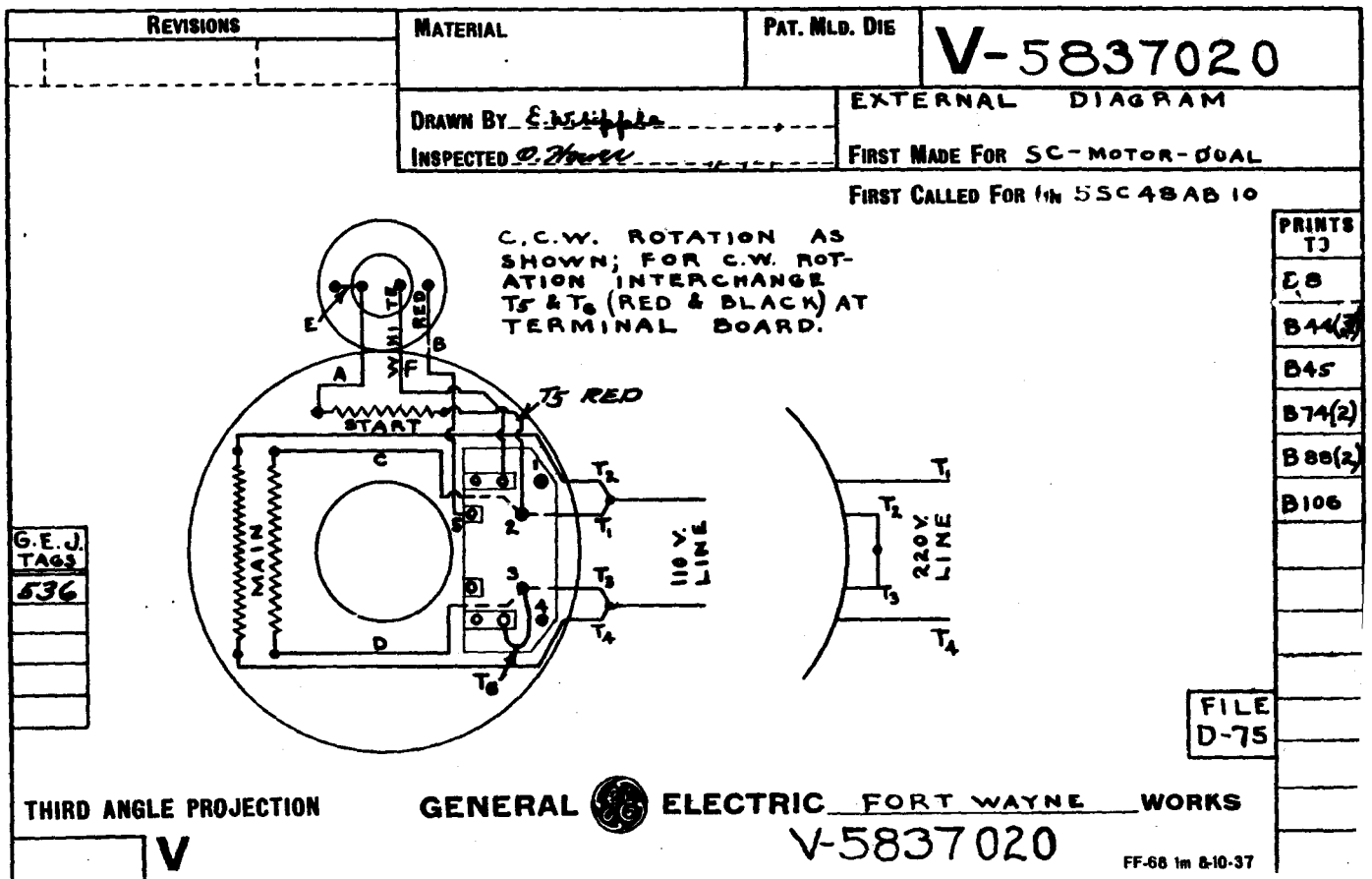
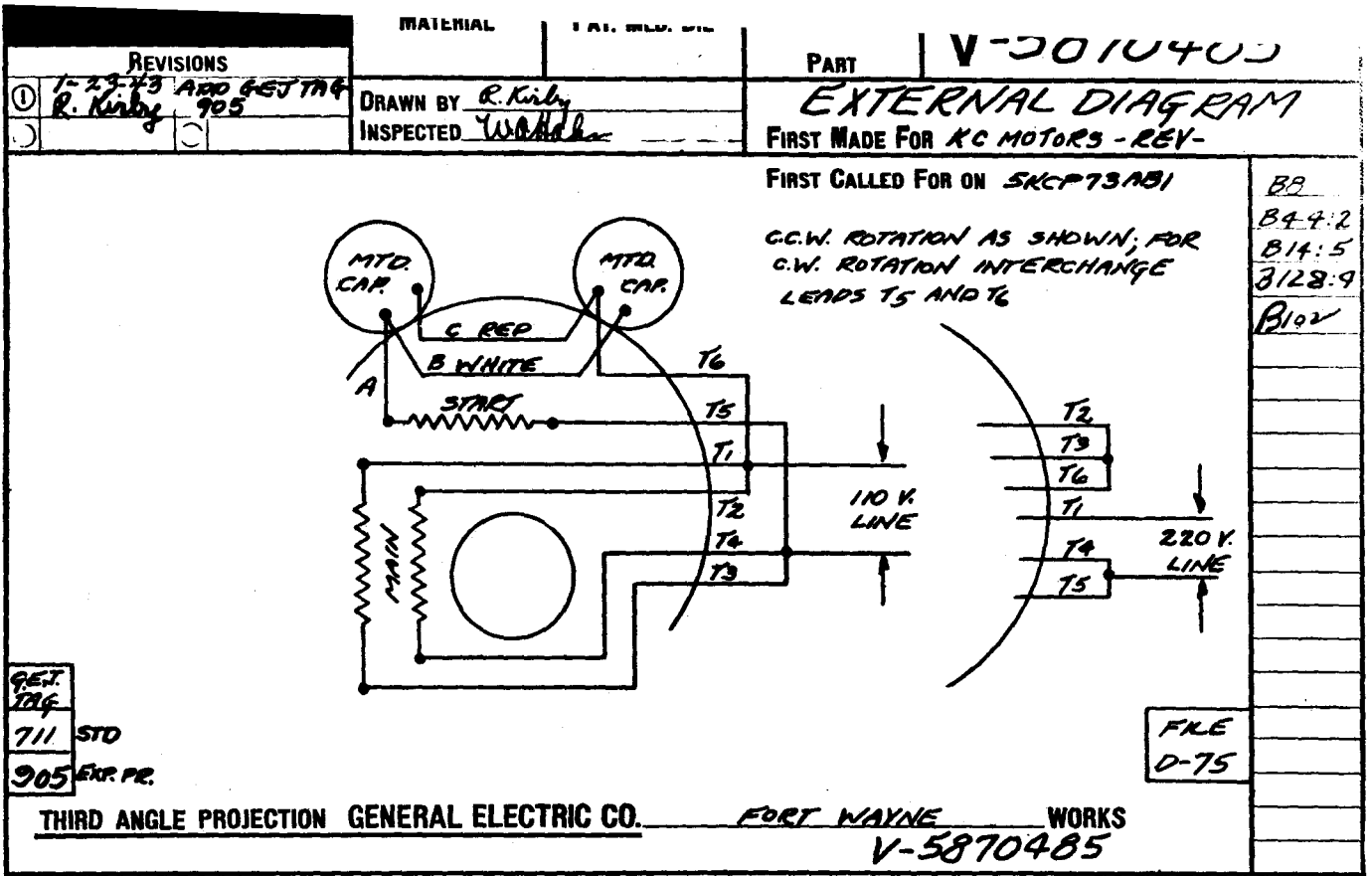



ENGINEERING INFORMATION

CAPACITOR START INDUCTION MOTORS

TYPES CSH & CSX; * 110 VOLTS; REVERSIBLE

Location of Terminals	* Frames	Internal Connection Diagrams (Counter Clockwise Rotation)	Label (Attached To Cover Over Terminals)
-----------------------	----------	---	--

WITHOUT OVERLOAD PROTECTION

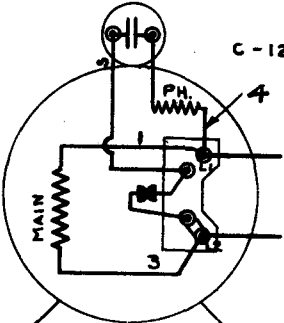
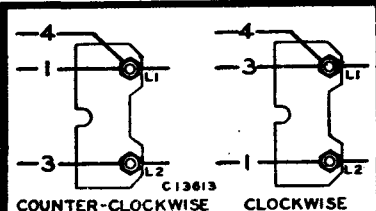
<p>In Front Bracket</p>	<p>63G, 65G, 67G, 65L 67L</p>	 <p>C-12185-A</p>	 <p>C13613 COUNTER-CLOCKWISE CLOCKWISE</p> <p>CENTURY ELECTRIC CO. 1120 ST. LOUIS, MO.</p>
<p>In Frame</p>	<p>71, 73, 81, 83, 91, 93</p>	<p>Standard Construction is Dual Voltage (See Page 7)</p>	

WITH OVERLOAD PROTECTION

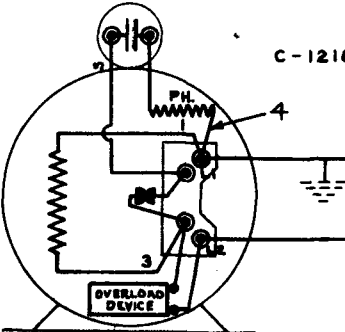
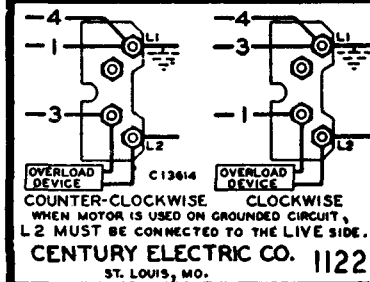
<p>In Front Bracket</p>	<p>63G, 65G, 67G, 65L, 67L</p>	 <p>C-12185-C</p>	 <p>C13614 OVERLOAD DEVICE OVERLOAD DEVICE</p> <p>COUNTER-CLOCKWISE CLOCKWISE WHEN MOTOR IS USED ON GROUNDED CIRCUIT, L2 MUST BE CONNECTED TO THE LIVE SIDE.</p> <p>CENTURY ELECTRIC CO. 1122 ST. LOUIS, MO.</p>
<p>In Frame</p>	<p>71, 73, 81, 83, 91, 93</p>	<p>Standard Construction is Dual Voltage (See Page 7)</p>	



ENGINEERING INFORMATION

CAPACITOR START INDUCTION MOTORS

TYPES CSH & CSX; * 110/220 VOLTS; REVERSIBLE

Location of Terminals	* Frame	Internal Connection Diagrams (Counter Clockwise Rotation)	Label (Attached To Cover Over Terminals)
-----------------------	---------	---	--

WITHOUT OVERLOAD PROTECTION

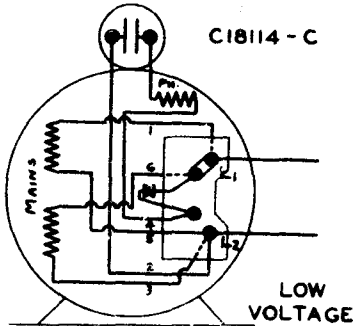
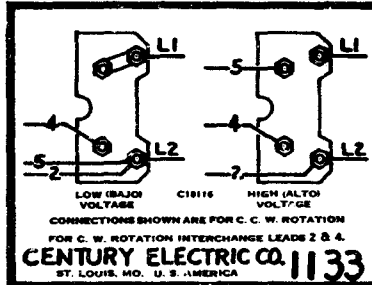
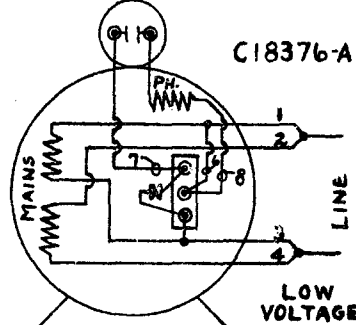
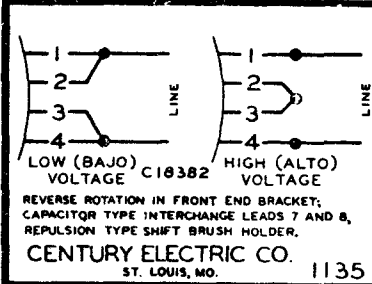
<p>In Front Bracket</p>	<p>63G, 65G, 67G, 65L, 67L</p>	 <p>C18114 - C</p> <p>LOW VOLTAGE</p>	 <p>LOW (BAJO) VOLTAGE C1133 HIGH (ALTO) VOLTAGE</p> <p>CONNECTIONS SHOWN ARE FOR C. W. ROTATION</p> <p>FOR C. W. ROTATION INTERCHANGE LEADS 2 & 4.</p> <p>CENTURY ELECTRIC CO. 1133</p> <p>ST. LOUIS, MO. U. S. A. MERICA</p>
<p>In Frame</p>	<p>71, 73, 81, 83, 91, 93</p>	 <p>C18376 - A</p> <p>LOW VOLTAGE</p>	 <p>LOW (BAJO) VOLTAGE C1135 HIGH (ALTO) VOLTAGE</p> <p>REVERSE ROTATION IN FRONT END BRACKET; CAPACITOR TYPE INTERCHANGE LEADS 7 AND 8, REPULSION TYPE SHIFT BRUSH HOLDER.</p> <p>CENTURY ELECTRIC CO. 1135</p> <p>ST. LOUIS, MO.</p>

WITH OVERLOAD PROTECTION

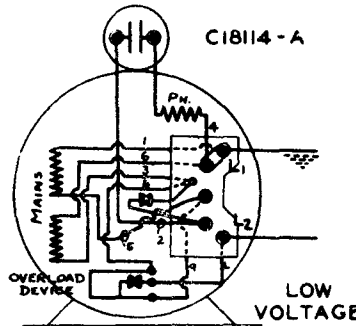
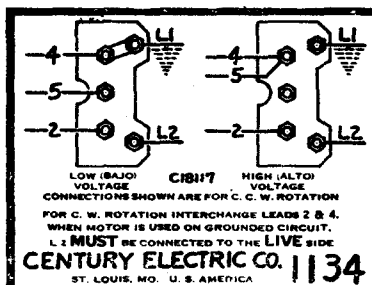
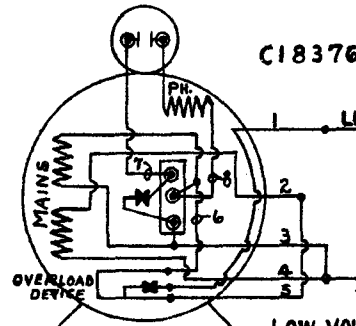
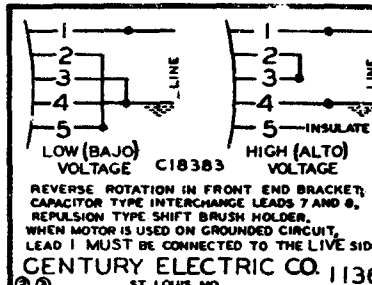
<p>In Front Bracket</p>	<p>63G, 65G, 67G, 65L, 67L</p>	 <p>C18114 - A</p> <p>LOW VOLTAGE</p>	 <p>LOW (BAJO) VOLTAGE C1134 HIGH (ALTO) VOLTAGE</p> <p>CONNECTIONS SHOWN ARE FOR C. W. ROTATION</p> <p>FOR C. W. ROTATION INTERCHANGE LEADS 2 & 4.</p> <p>WHEN MOTOR IS USED ON GROUNDING CIRCUIT, L1 MUST BE CONNECTED TO THE LIVE SIDE</p> <p>CENTURY ELECTRIC CO. 1134</p> <p>ST. LOUIS, MO. U. S. A. MERICA</p>
<p>In Frame</p>	<p>71, 73, 81, 83, 91, 93</p>	 <p>C18376 - C</p> <p>LOW VOLTAGE</p>	 <p>LOW (BAJO) VOLTAGE C1136 HIGH (ALTO) VOLTAGE</p> <p>REVERSE ROTATION IN FRONT END BRACKET; CAPACITOR TYPE INTERCHANGE LEADS 7 AND 8, REPULSION TYPE SHIFT BRUSH HOLDER.</p> <p>WHEN MOTOR IS USED ON GROUNDING CIRCUIT, LEAD 1 MUST BE CONNECTED TO THE LIVE SIDE.</p> <p>CENTURY ELECTRIC CO. 1136</p> <p>ST. LOUIS, MO.</p>



ENGINEERING INFORMATION

SPLIT PHASE AND CAPACITOR START INDUCTION MOTORS

"3 LEAD" TWO SPEED - REVERSIBLE - TWO WINDING

CONSTANT OR VARIABLE TORQUE

TYPES CSXM - 110 V; SPM[▲] 110 OR 220 V*

LOCATION OF TERMINALS	FRAME	INTERNAL CONNECTION DIAGRAMS	
		COUNTER CLOCKWISE ROTATION	CLOCKWISE ROTATION

WITHOUT OVERLOAD PROTECTION

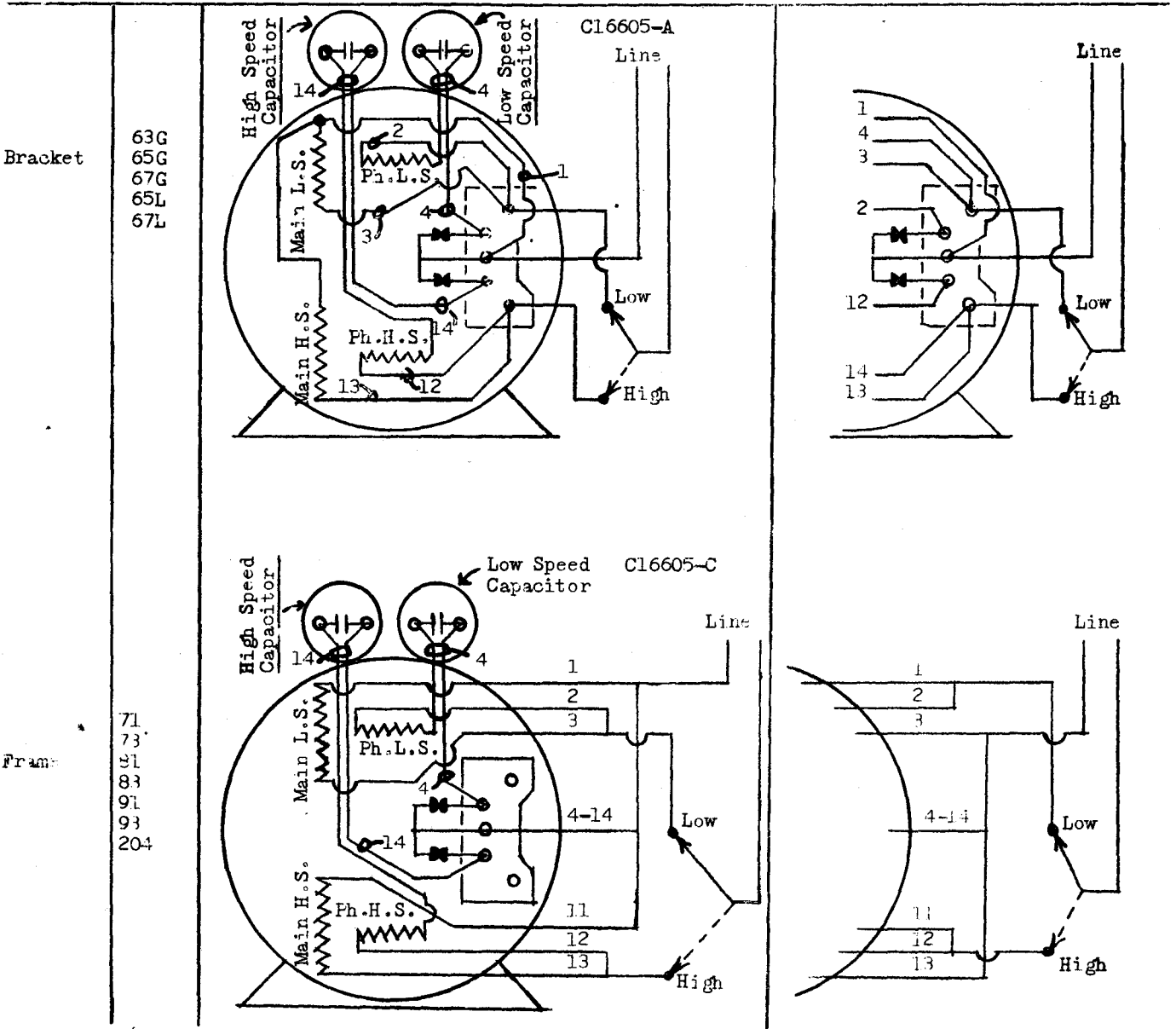

▲ - SPM do not have Capacitor; otherwise same diagram applies

* - See price sheets for standard voltage and horsepower for individual frames.

ENGINEERING INFORMATION

CONNECTION PLATES FOR MULTI-SPEED MOTORS

2 SPEED 2 WINDING

CONSTANT OR VARIABLE TORQUE

TYPES CPXM - CPHM

1 PHASE

Capacitor unit mounted on motor.

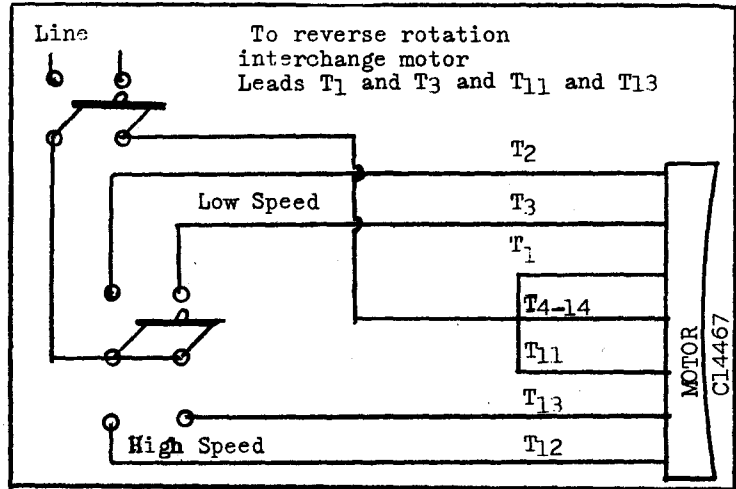

Similar to C14467

Motor with separate Capacitor unit and relay.

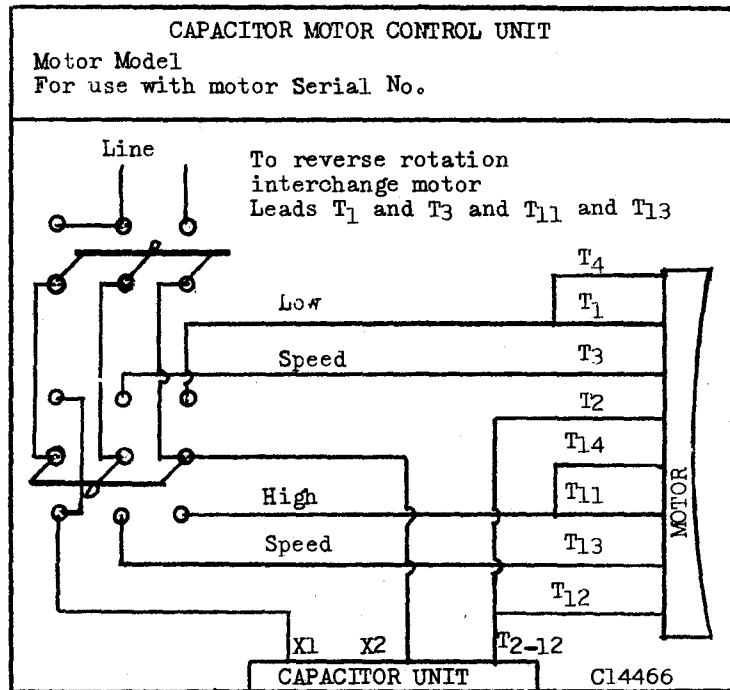

Similar to C14466

These diagrams are similar to the plates attached to motors when they leave the factory.

March 4, 1940

Centrol

CONNECTIONS FOR TYPE 'C' UNIT HEATER MOTOR

MOTOR TERMINALS IN END BRACKET

MOTOR LEADS IN TERMINAL BOX

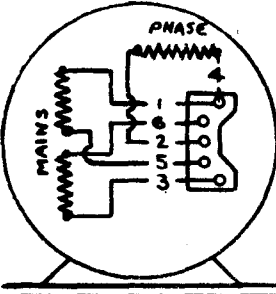

ALL CONNECTIONS SHOWN ARE FOR C.C.W. ROTATION FACING END OPPOSITE DRIVE
FOR C.W. ROTATION INTER-CHANGE LEADS 2 AND 4

CAPACITOR

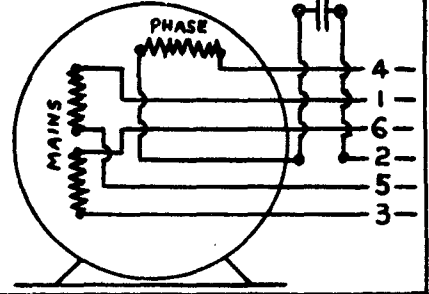

C16494

SINGLE SPEED DUAL VOLTAGE

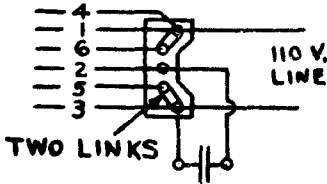

CONNECTIONS FOR 110 VOLT

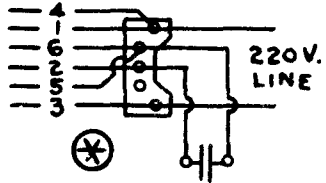
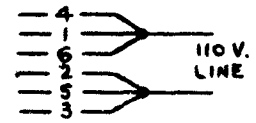

CONNECTIONS FOR 220 VOLT

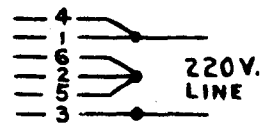

TWO SPEED SINGLE VOLTAGE

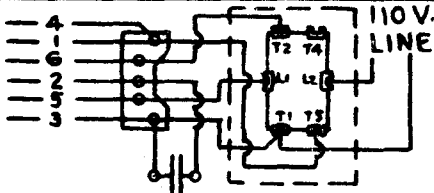

ON 110 VOLT USING H. & H., SWITCH #80788

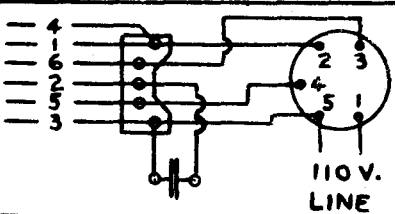
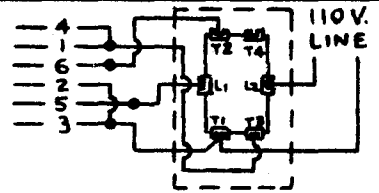

ON 110 VOLT USING H. & H., SWITCH #70232 OR G.E. SWITCH #68x49A

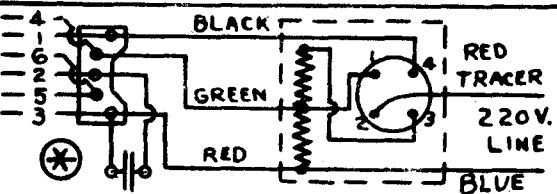
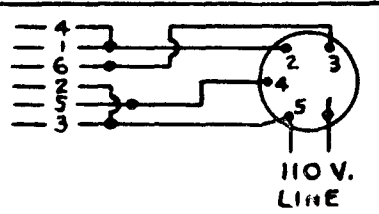

CONNECTIONS FOR 220 VOLT USING TRANSFORMER AND SWITCH

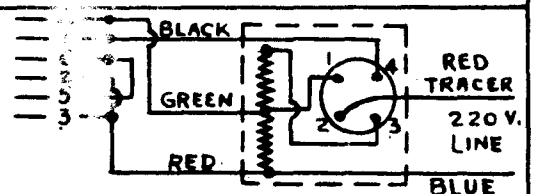

VARIABLE SPEED DUAL VOLTAGE

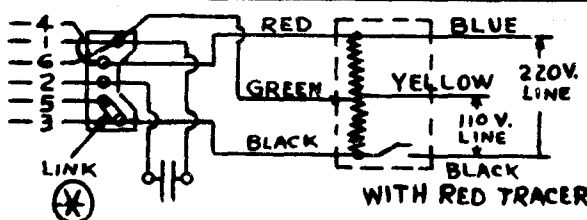

ON 110 OR 220 VOLT LINE WITH VARIABLE SPEED CONTROLLER

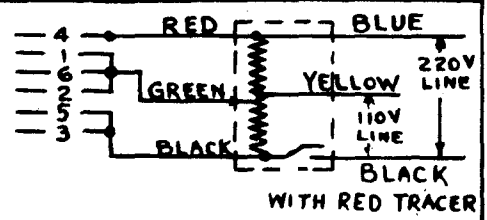

⊗ TERMINAL BOARD CONNECTIONS MUST BE MADE AS SHOWN

CENTURY ELEC. CO. ST. LOUIS, MO.

C16494 9-16-39 W.J.B.

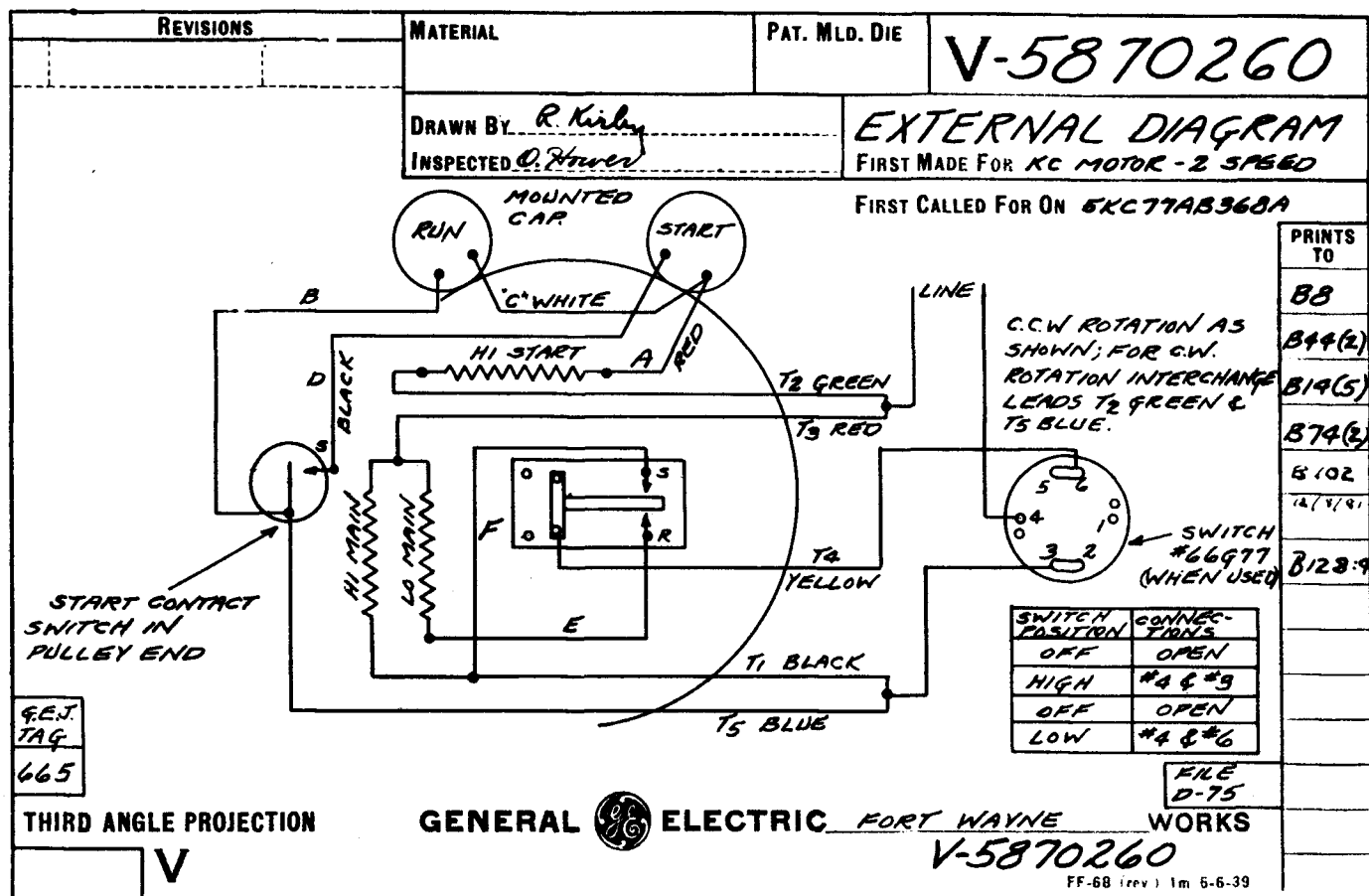
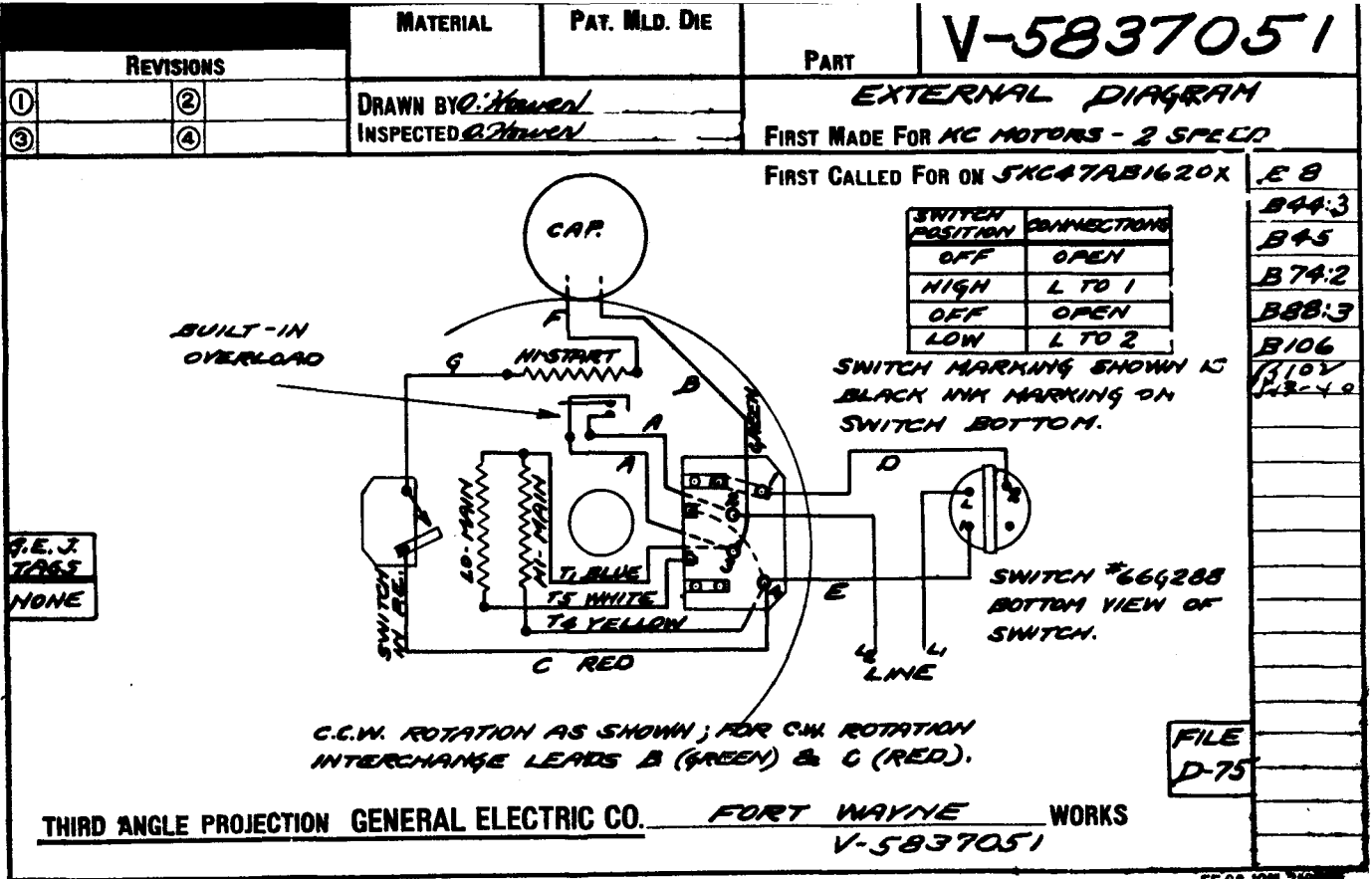

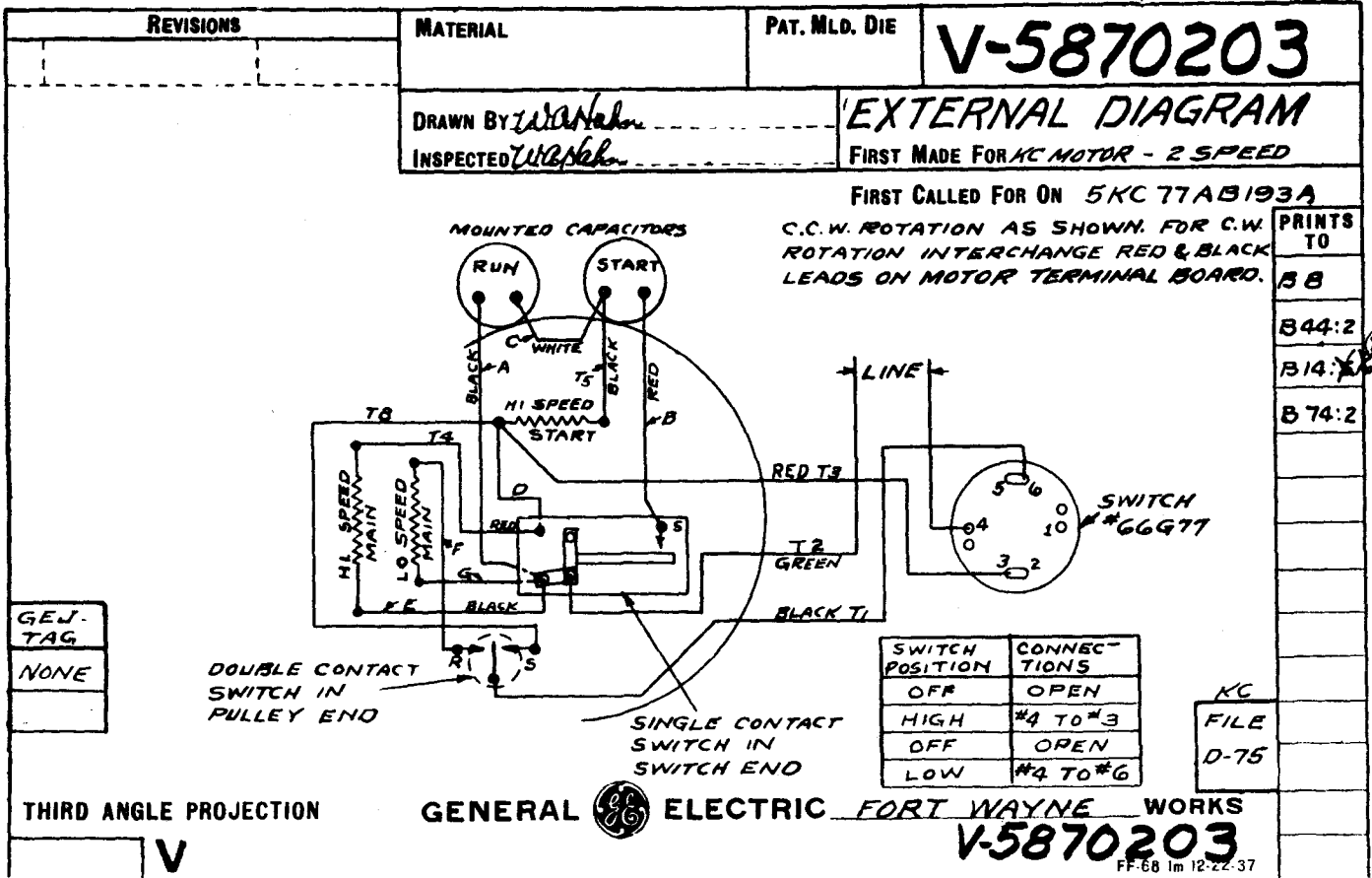

PRINTS TO

BB

B44:2

B14:2

B74:2

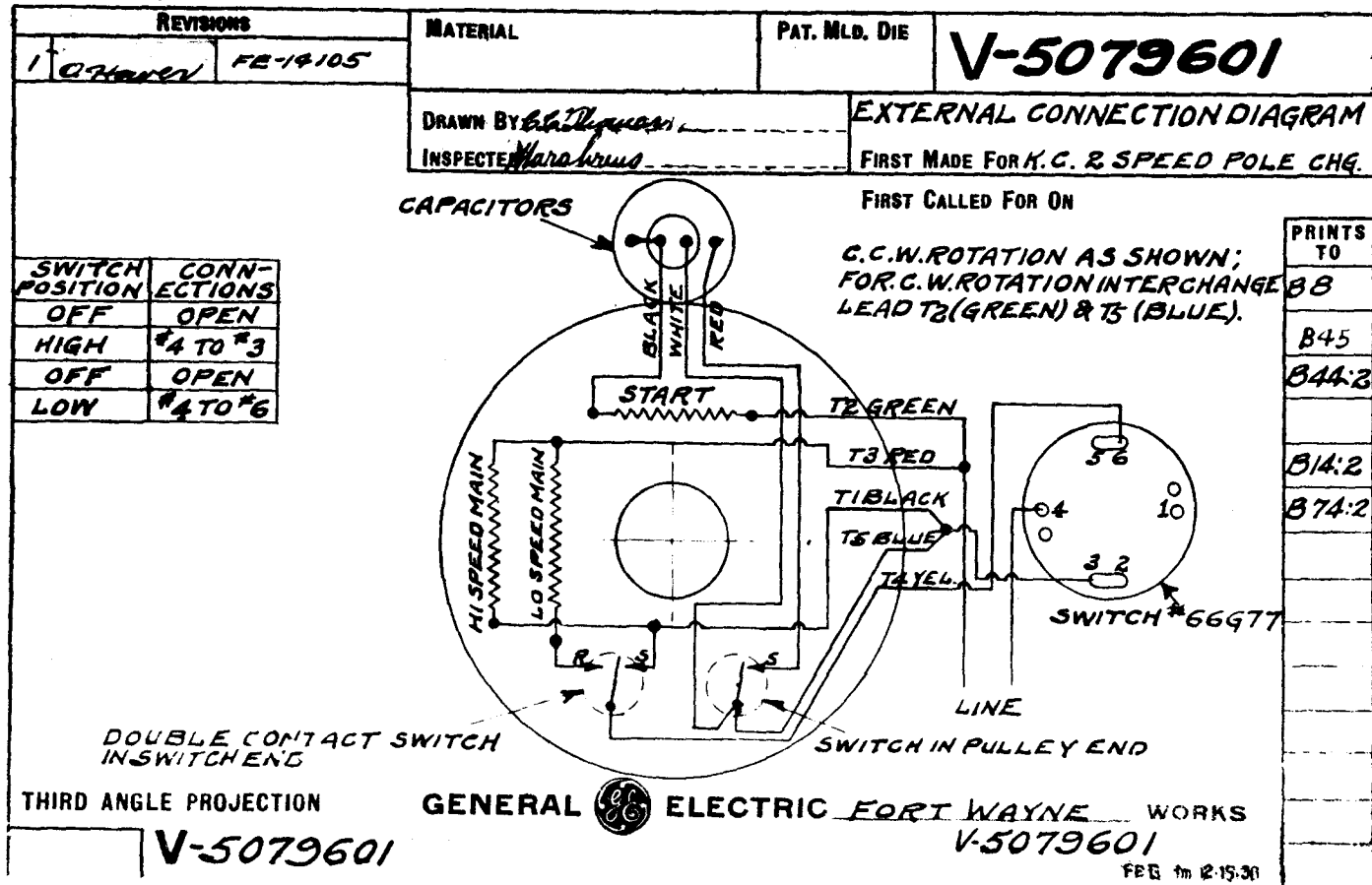

PRINTS TO

BB

B45

B44:2

B14:2

B74:2

REVISIONS

MATERIAL

PAT. MLD. DIE

V-5870449

DRAWN BY *R. Kirby*
INSPECTED *D. Hoover*

EXTERNAL DIAGRAM
FIRST MADE FOR KE POLE CHANGING

FIRST CALLED FOR ON SKC49AB270X

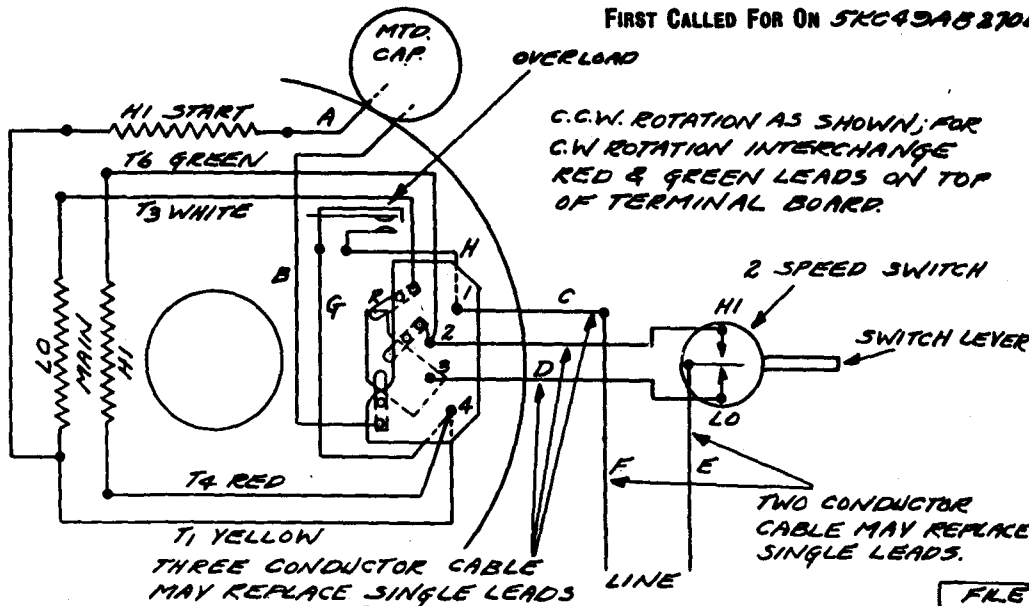

PRINTED TO
88
894:2
860:2
874:2
888:2
8106
8102
4-24-4
8128:4

GET TAG
NONE

THIRD ANGLE PROJECTION

V

GENERAL ELECTRIC FORT WAYNE WORKS

V-5870449

FF-68 1m 12-22-37

FILE
D-75

MATERIAL

PAT. MLD. DIE

PART

V-5872054

①	②
③	④

DRAWN BY *R. Kirby*
INSPECTED *R. Kirby*

EXTERNAL DIAGRAM
FIRST MADE FOR KCP MOTOR - 3 LEAD REV-

FIRST CALLED FOR ON SKCP47AB85X

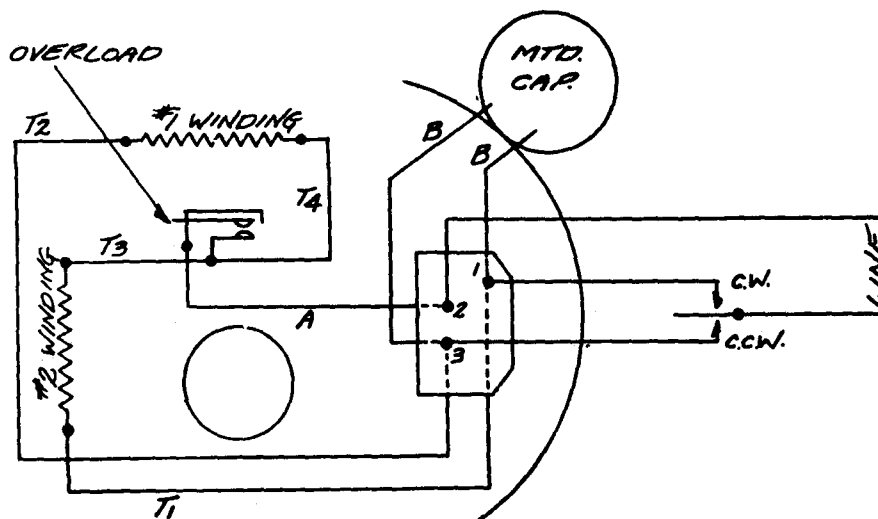

88
844(2)
888(4)
8106
8128:4
8102

GET TAG
NONE

THIRD ANGLE PROJECTION

GENERAL ELECTRIC CO. FORT WAYNE WORKS

V-5872054

FF-68 10M 10-13-27

KCP
FILE
D-75

REVISIONS	MATERIAL	PAT. MLD. DIE	V-5837425
DRAWN BY <i>W. A. Holme</i>		EXTERNAL DIAGRAM	
INSPECTED <i>O. Hoover</i>		FIRST MADE FOR <i>SMY MOTORS</i>	
FIRST CALLED FOR ON <i>SMY50H25</i>			

GET TAG
 NONE

PRINTS TO
 B8
 B44:2
 B4
 B9:2
 B3:2
 B6
 B74:2

THIRD ANGLE PROJECTION
V

GENERAL ELECTRIC **WORKS**
 FORT WAYNE
V-5837425
FF-68 Im 12-22-37

REVISIONS	MATERIAL	PAT. MLD. DIE	V-5837082
DRAWN BY <i>R. Kirby</i>		EXTERNAL DIAGRAM	
INSPECTED <i>O. Hoover</i>		FIRST MADE FOR <i>KC MOTOR-3 STUD REV.</i>	
FIRST CALLED FOR ON <i>5XC47AD.483</i>			

GET TAG
 NONE

PRINTS TO
 B8
 B44:3
 B45
 B74:2
 B84:2
 B88:3
 B106
 B102
 3-7-41
 B80(2)
 4-4-41

THIRD ANGLE PROJECTION
V

GENERAL ELECTRIC **WORKS**
 FORT WAYNE
V-5837082
FF-68 Im 12-22-37

FILE
 D-75

REVISIONS

MATERIAL

PAT. MLD. DIE

V-5870273

DRAWN BY *R. Kirby* JULY-7-41
 INSPECTED *R. Kirby* JULY-10-41

EXTERNAL DIAGRAM
 FIRST MADE FOR KC MOTOR - REV-2 CAP.

FIRST CALLED FOR ON 5KCP37YD1

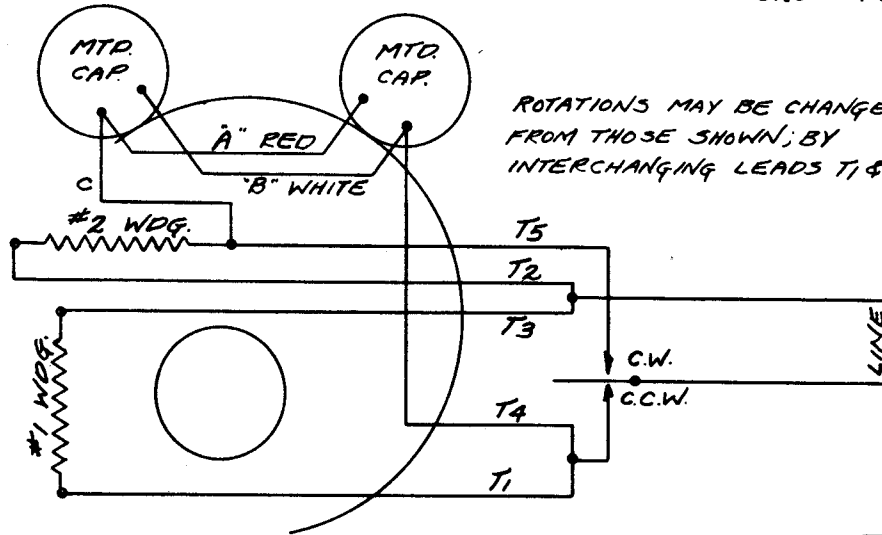

ROTATIONS MAY BE CHANGED FROM THOSE SHOWN; BY INTERCHANGING LEADS T1 & T3.

PRINTS TO
 B8
 B44(2)
 B74(2)
 B3(2)
 B9(2)
 B128-4

G.E.J.
 TAG
 1073

FILE
 D-75

THIRD ANGLE PROJECTION

GENERAL ELECTRIC FORT WAYNE WORKS

V-5870273

FF-68 (rev.) 1m 6-6-39

REVISIONS

MATERIAL

PAT. MLD. DIE

PART

V-5830564

① *Thomas*
 ②
 ③
 ④

DRAWN BY *G. Thomas*
 INSPECTED *H. Hayley*

EXTERNAL CONNECTION DIAGRAM

FIRST MADE FOR SMY MOTORS

FIRST CALLED FOR ON

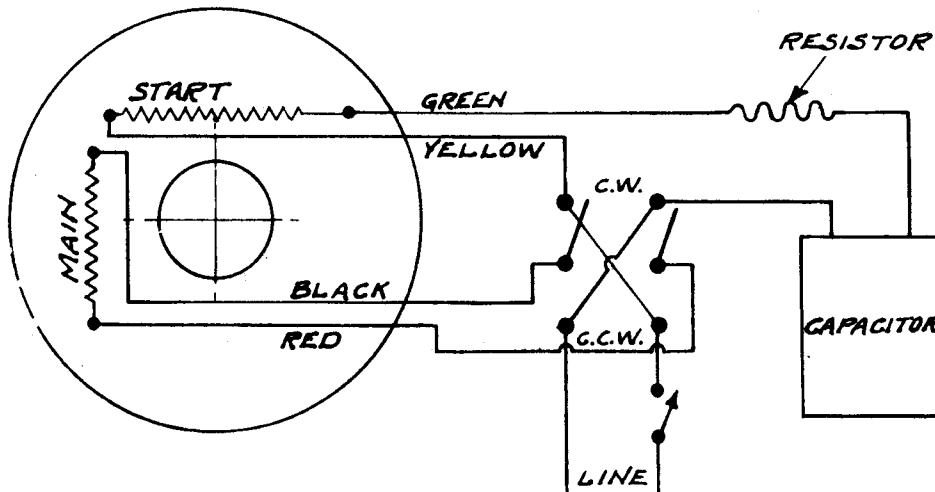

B8
 B4:2
 B44
 B45
 B9:2
 B3:2
 B6
 B74:2

G.E.J.
 TAG
 842

FILE
 D75

THIRD ANGLE PROJECTION GENERAL ELECTRIC CO. FORT WAYNE WORKS

V-5830564

FF-68 100 TO 22-30

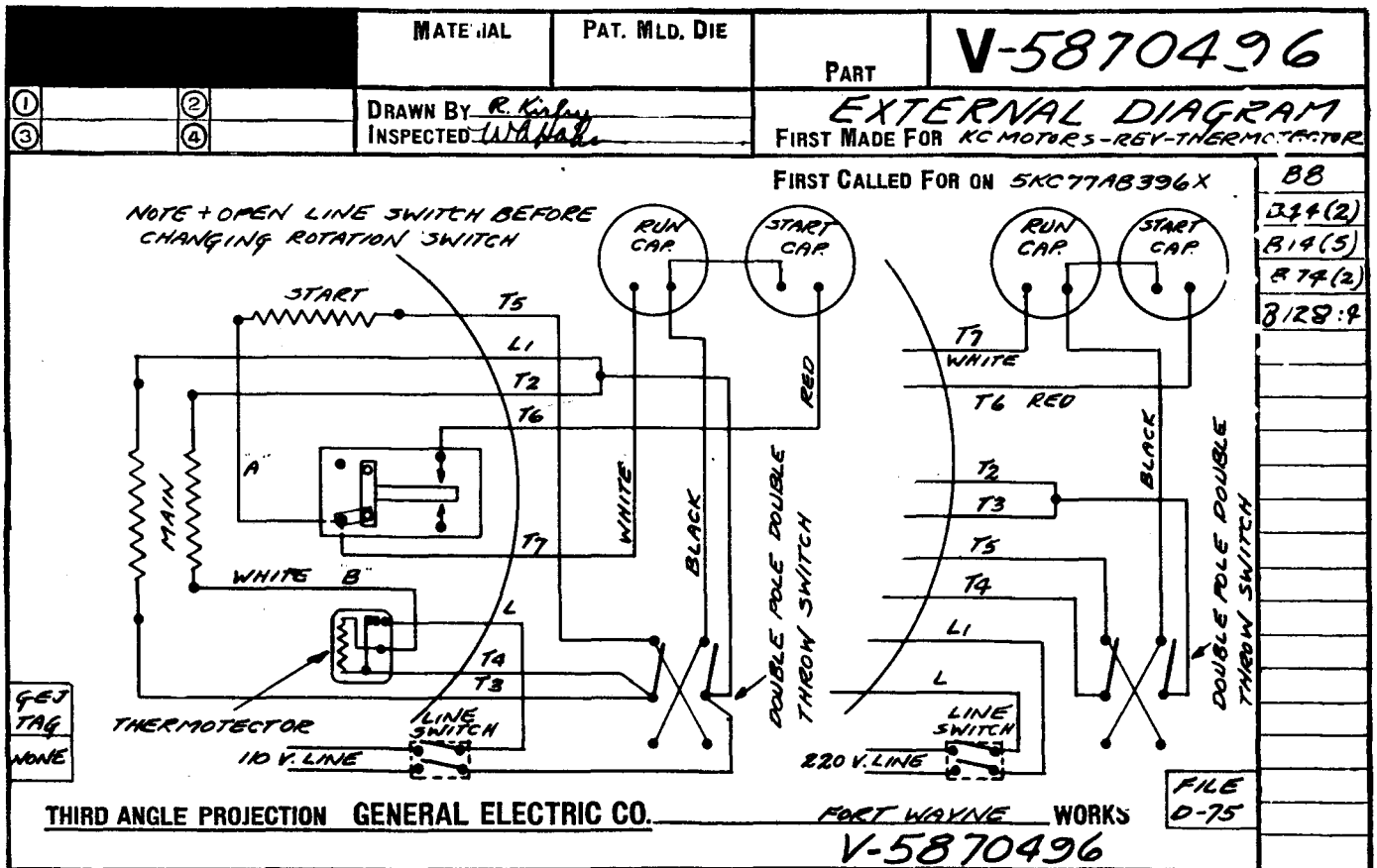
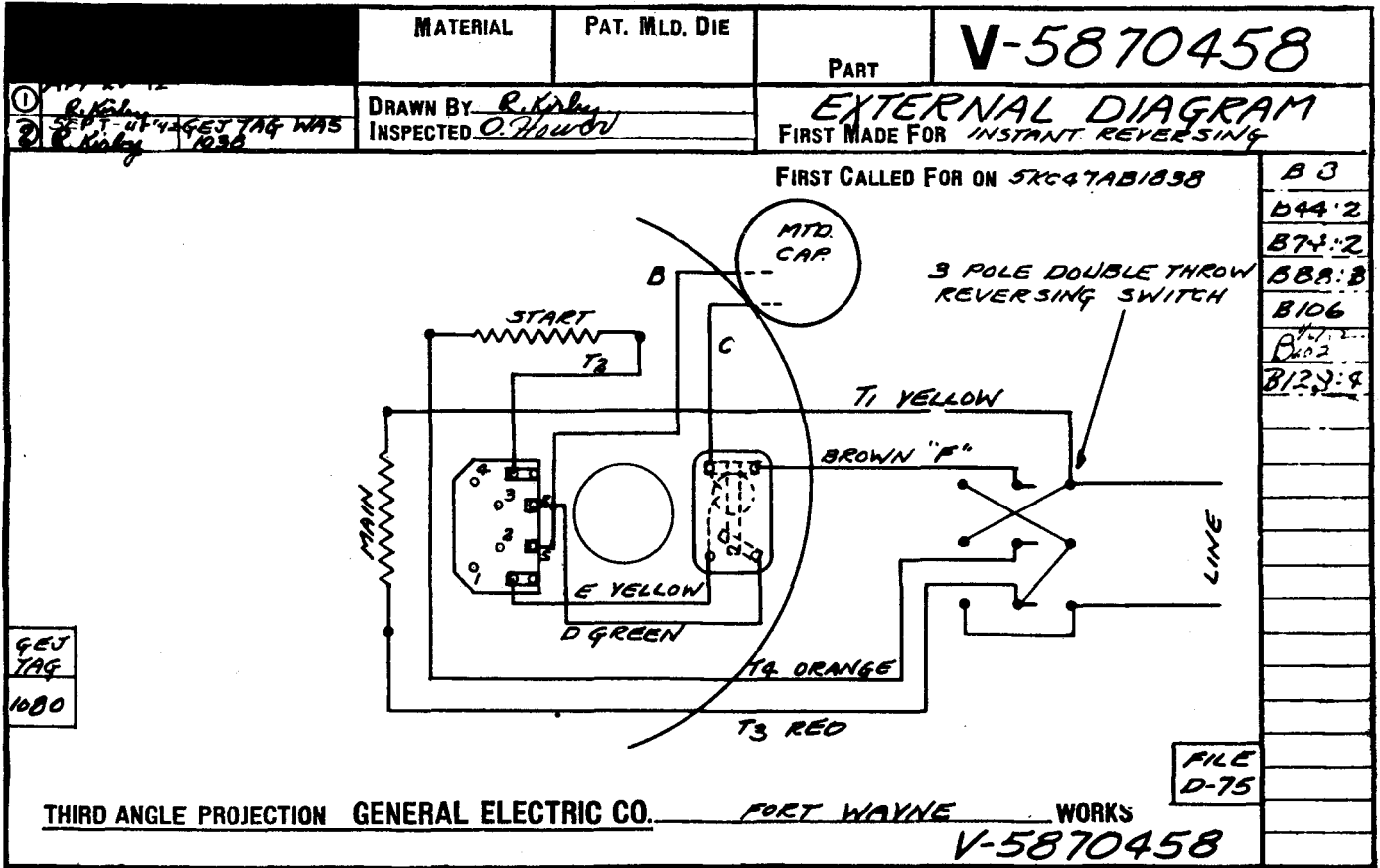

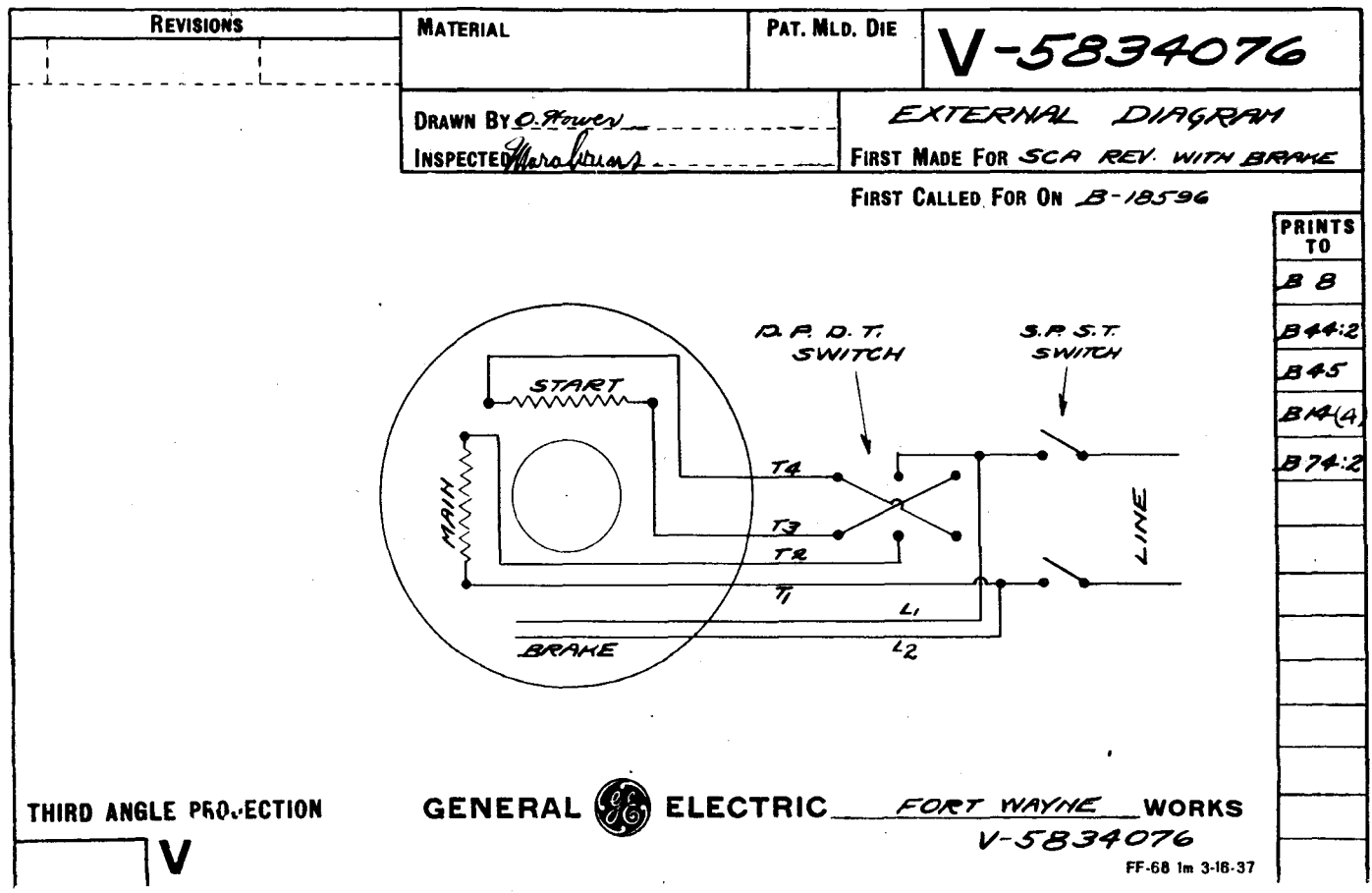
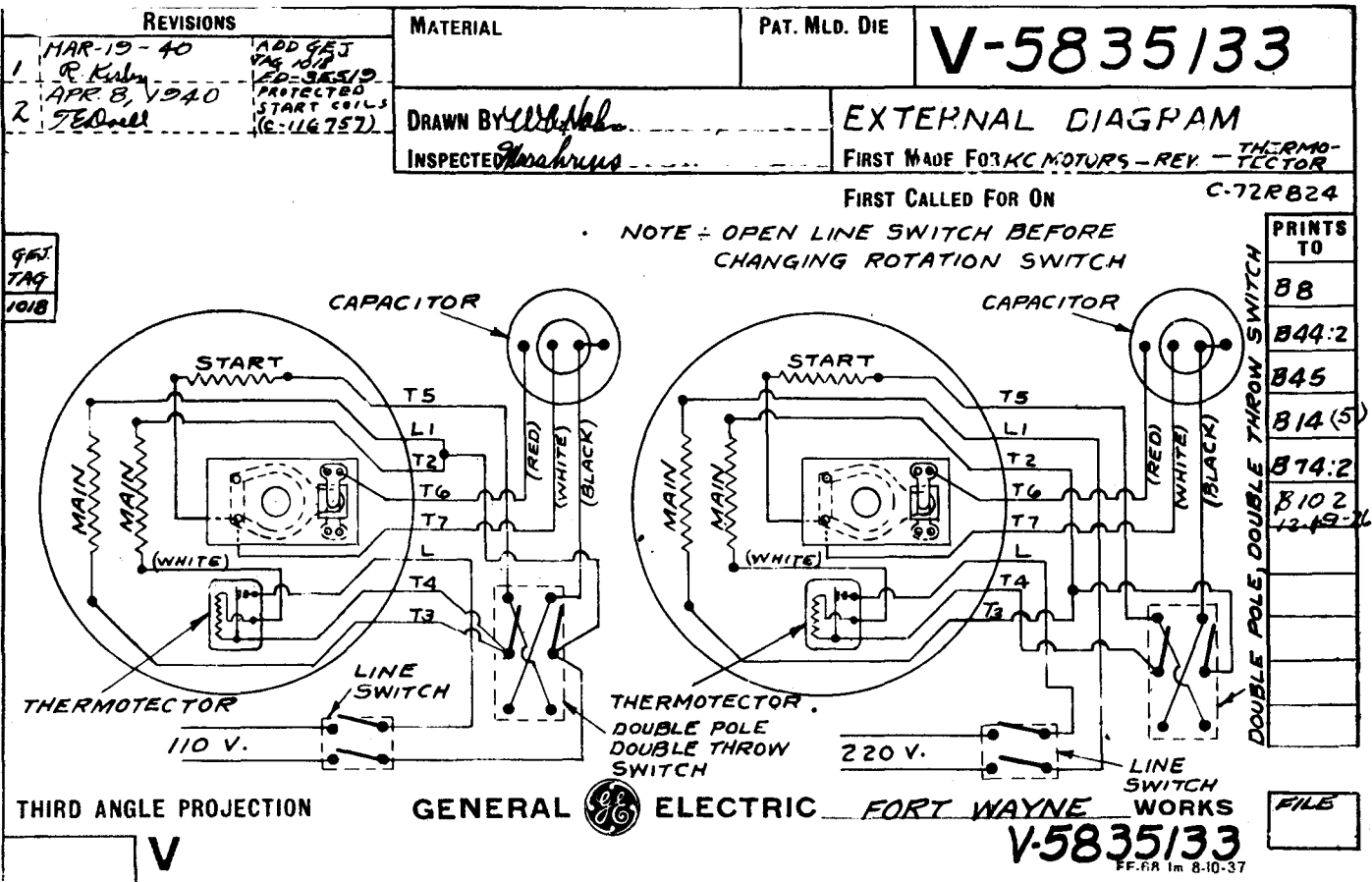

REPULSION-START-INDUCTION MOTOR

Job No. 1 B

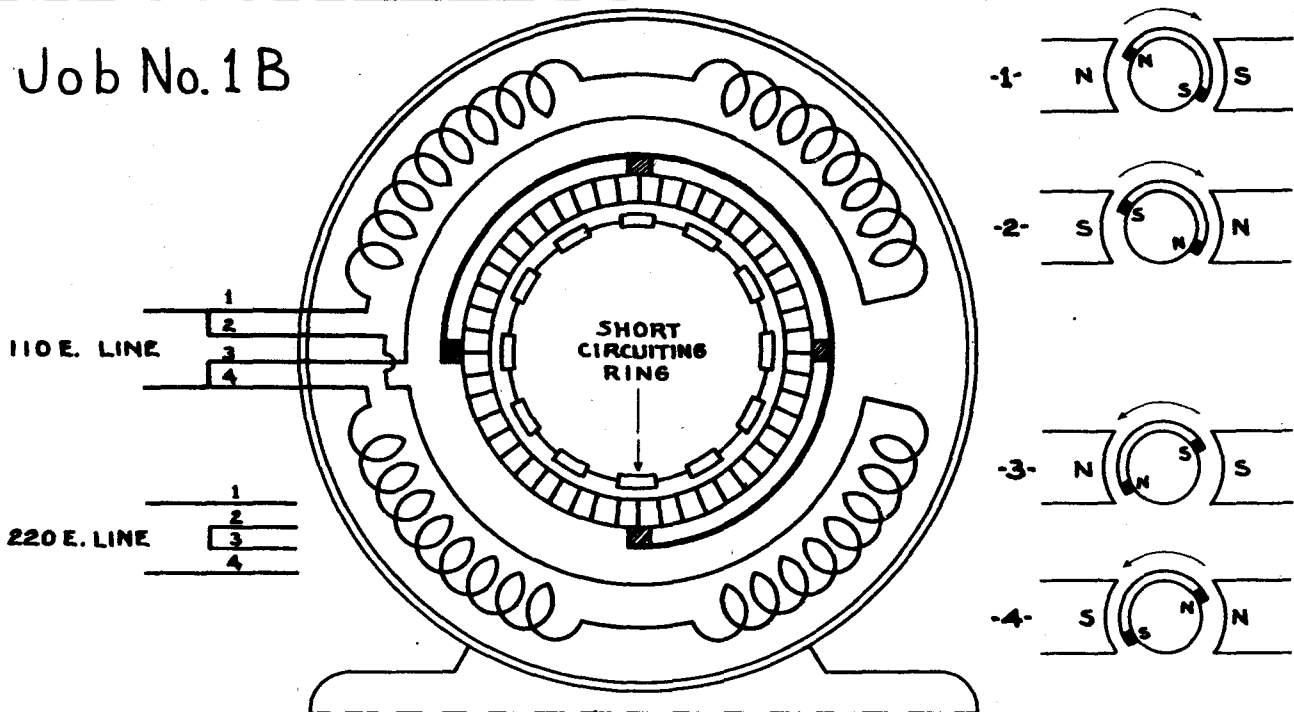

OPERATION

In this motor are combined the high starting torque of the repulsion-type and the good speed regulation of the induction motor. The stator of this machine is provided with a regular single-phase winding, while the rotor winding is similar to that used on a D.C. motor. When starting, the changing single-phase stator flux cuts across the rotor windings inducing currents in them, that, when flowing through the commutator and brushes, set up poles on the rotor which remain stationary in space and maintain a continuous repulsive action upon the stator poles. This motor starts as a straight repulsion-type and accelerates to about 75% of normal full speed when a centrifugally operated device connects all the commutator bars together and converts the winding to an equivalent squirrel-cage type. The same mechanism usually raises the brushes to reduce noise and wear. Note that, when the machine is operating as a repulsion-type, the rotor and stator poles reverse at the same instant, and that the current in the commutator and brushes is A.C.

CHARACTERISTICS

This motor will develop 4 to 5 times normal full load torque and will draw about 3 times normal full load current when starting with full line voltage applied. The speed variation from no load to full load will not exceed 5% of normal full load speed. For complete data on current, torque, etc., see curves below.

APPLICATION

Air compressors, refrigeration compressors, plunger-type pumps, meat-grinders, small lathes, small conveyors, stokers, etc. In general, this type of motor is suitable for any load that requires a high starting torque and constant speed operation. Most motors of this type are less than 5 h.p.

TROUBLES

Commutator, brushes, centrifugal switch, short-circuiting rig, bearings, oil-soaked insulation, solder thrown out of commutator, too much or too little tension on the throw-out spring; opens, shorts, or grounds in the rotor or stator windings. Rotation is reversed by shifting the brushes.

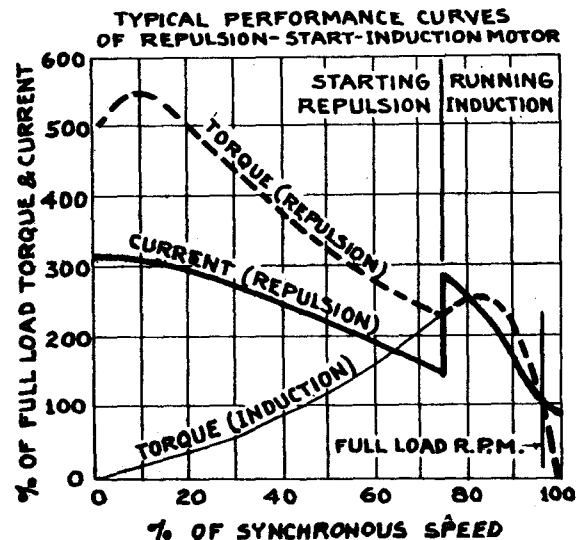



ENGINEERING INFORMATION

REPULSION START INDUCTION MOTORS

TYPE RS; 110/220 VOLTS; REVERSIBLE

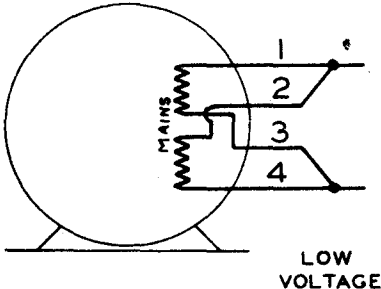
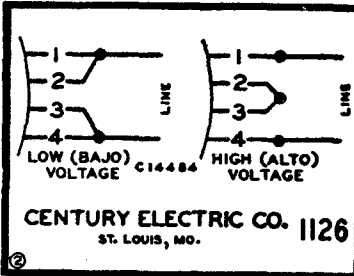
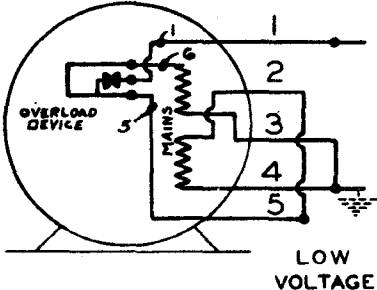
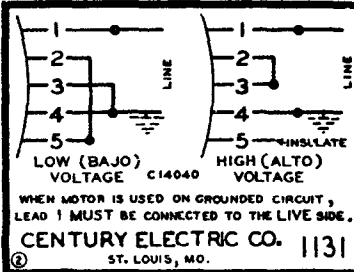
Frame	Internal Connection Diagrams	Label (Attached To Cover Over Terminals)
WITHOUT OVERLOAD PROTECTION		
All	 <p style="text-align: right;">LOW VOLTAGE</p>	 <p style="text-align: center;">CENTURY ELECTRIC CO. 1126 ST. LOUIS, MO.</p>
WITH OVERLOAD PROTECTION		
1/8 HP All 1/6 HP and Larger	<p>Dual Voltage Overload Device not available. 110 V. Device supplied - Connected in series in Line Lead.</p> <p style="text-align: center;">C-14241</p>  <p style="text-align: right;">LOW VOLTAGE</p>	<p>Two (2) Lead Motors with Ground Marker On Lead without Overload Device. No Label Furnished</p>  <p style="text-align: center;">CENTURY ELECTRIC CO. 1131 ST. LOUIS, MO.</p>

REPULSION-INDUCTION MOTOR

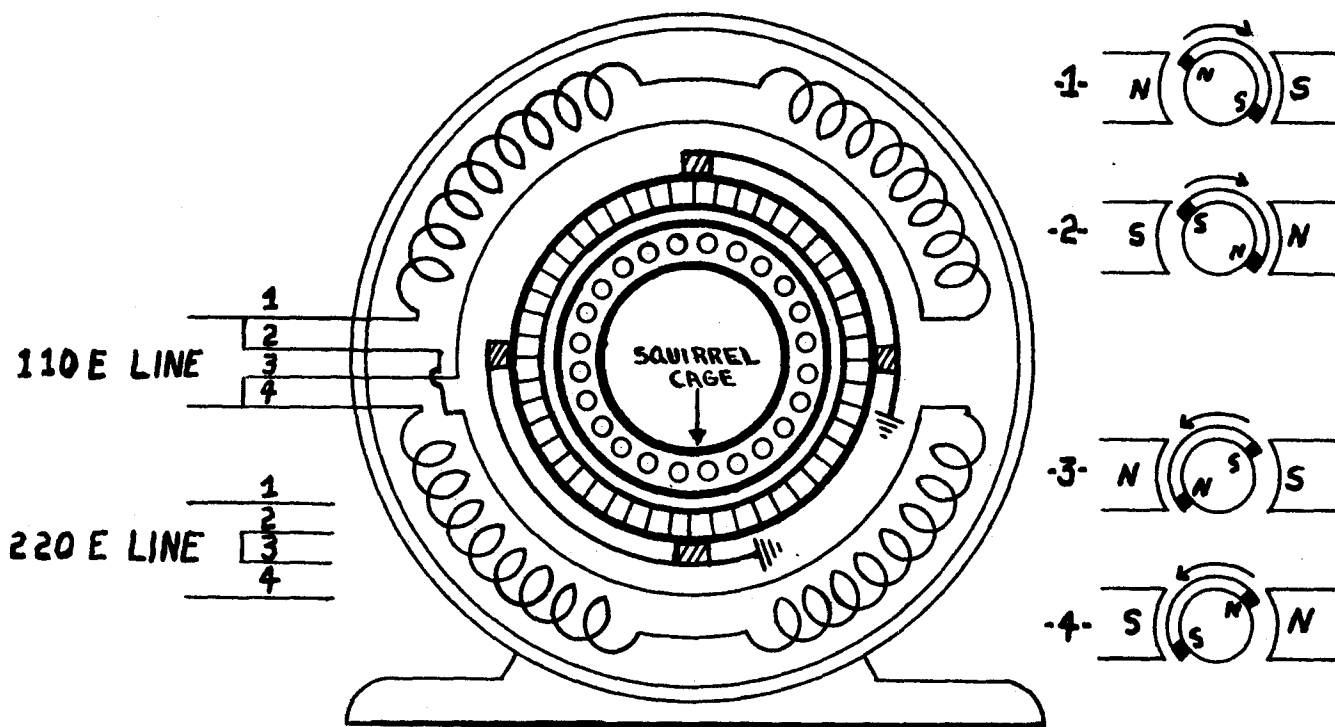

OPERATION

This motor is different from the repulsion-start-induction type in that it has no centrifugal switching mechanism, no short-circuiting device, and no brush raising equipment. Starting as a straight repulsion type, this motor combines both repulsion and induction operation when running. In addition to the regular winding, the rotor of this motor is equipped with a squirrel cage as shown in the diagram above. Both windings are located in the same slots and the squirrel cage, although inactive at the instant of starting, develops a gradually rising torque as the speed increases. When normal speed is reached both windings are carrying load. A further advantage of the squirrel cage lies in its speed regulating action, this effect tending to maintain constant speed with variable load. The advantages claimed for this type of motor are no centrifugal or short-circuiting mechanism to give trouble, good commutation, simple construction, and a high power factor during operation at or near full load.

CHARACTERISTICS

This motor will develop 4 times normal full load torque with $3\frac{1}{2}$ times normal full load current. The variation in speed from no load to full load will not exceed 5% of the normal full load speed. See curves below.

APPLICATION

Air compressors, pumps, strokes, hoists, conveyors, machine tools, dairy machinery, etc. In general, this motor is suitable for any type of load requiring a high starting torque and constant speed operation.

PRINCIPAL TROUBLES

Commutator, brushes, brush holder, bearings, insulation, and opens, grounds, shorts, and loose connections in either the rotor or stator windings.

The repulsion type motor is very sensitive to brush setting, and for this reason the manufacturer marks the brush holder and housing to facilitate brush positioning. One commutator bar from the correct position may cause unsatisfactory operation. To reverse the direction of rotation, shift the brushes.

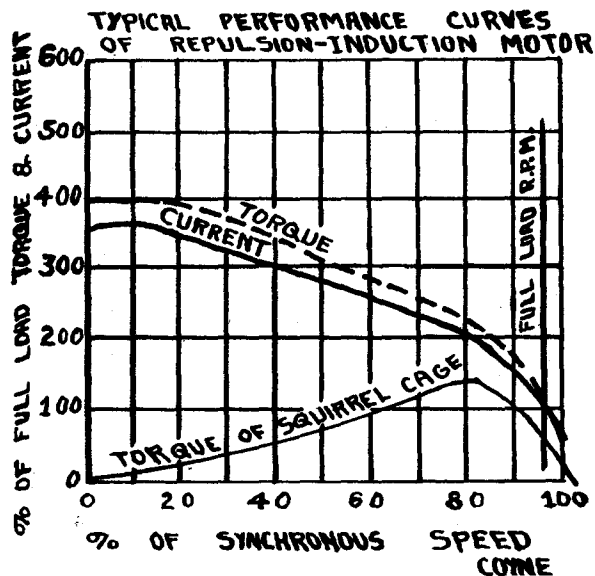

Single-Phase Motors

Shaded-Pole Type

The shaded-pole type is one of the simplest self-starting single-phase motors. It has a stator, Fig. 1, like the field frame of a dc motor, built of laminated steel. A slot cut across each pole face holds a closed-circuit coil, called a shading coil, Figs. 1 and 2. This is often only a rectangular copper stamping.

When current increases in the main coils, a current is induced in the shading coils that opposes the magnetic field building up in the part of the polepieces they surround. This produces the condition of Fig. 3. When the main-coil current decreases, that in the shading coils also decreases until the polepieces are uniformly magnetized. As the main-coil current and the polepiece magnetic flux continue to decrease, current in the shading coils reverses and tends to maintain the flux in part of the polepieces.

When the main-coil current drops to zero, current still flows in the shading coils to give the magnetic effect, Fig. 5. By comparing Figs. 3, 4 and 5, one can see that the magnetic field has moved across the polepieces from left to right, showing how the shading coils produce a rotating magnetic field that makes the motor self-starting. This type of motor suits applications where starting torque is low, such as small fans, and comes in fractional horsepower sizes only.

The split-phase motor with running and starting windings in the stator, represents another self-starting single-phase type. The winding produces conditions at starting resembling those in a 2-phase motor.

Fig. 6 shows one design of split-phase motor. The main coils have comparatively low resistance and occupy about 75% of the slot space. A high-resistance starting winding fills the remaining slot space, displaced from the main winding by 90 electrical degrees.

Split-phase motors are also built with an external reactor, Fig. 7, connected in series with the main winding at starting. At about 75% operating speed the starting switch throws from start to run position, opens the starting winding circuit and short circuits the reactor. Adding the external reactor reduces the starting current and increases the current lag in the main winding.

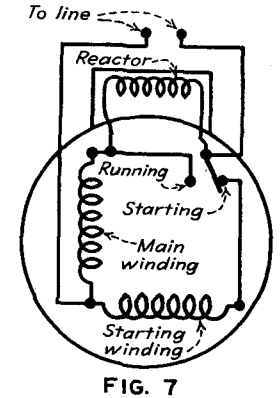
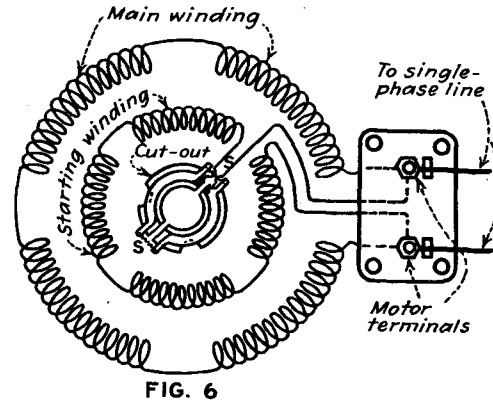
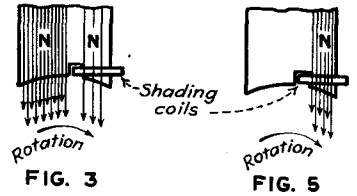
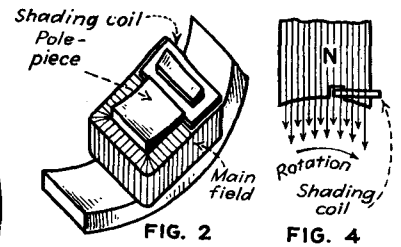
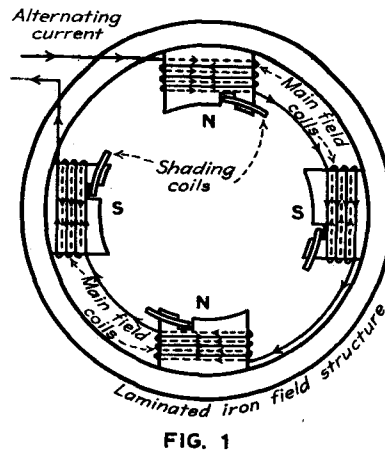

Figs. 1 to 5—How a shaded-pole, single-phase motor operates. Fig. 6—Diagram of split-phase motor. Fig. 7—Diagram of split-phase motor with external reactor

TABLE I—STANDARD HORSEPOWER AND SYNCHRONOUS-SPEED RATINGS OF CONTINUOUS-DUTY, GENERAL-PURPOSE INDUCTION MOTORS

Cycle	60	60	60	60	60	60	60	25	25	25
Hp	Rpm	Rpm	Rpm	Rpm	Rpm	Rpm	Rpm	Rpm	Rpm	Rpm
1/2			1,200							750
3/4			1,200							750
1		1,800	1,200					1,500		750
1.5	3,600	1,800	1,200					1,500		750
2	3,600	1,800	1,200		900			1,500		750
3	3,600	1,800	1,200		900			1,500		750
5	3,600	1,800	1,200		900			1,500		750
7.5	3,600	1,800	1,200		900			1,500		750
10	3,600	1,800	1,200		900			1,500		750
15	3,600	1,800	1,200		900		600	1,500	750	500
20	3,600	1,800	1,200		900		600	1,500	750	500
25		1,800	1,200		900		600	1,500	750	500
30		1,800	1,200		900		600	1,500	750	500
40		1,800	1,200		900		600	1,500	750	500
50			1,200		900		600		750	500
60			1,200		900		600		750	500
75			1,200		900		600		750	500
100					900		600		750	500
125					900	720	600	450	750	500
150						720	600	450	750	500
200						720	600	450	750	500

SHADED POLE MOTORS.

A SHADED POLE MOTOR is a single phase induction motor provided with an uninsulated and permanently short-circuited AUXILIARY WINDING displaced in magnetic position from the main winding.

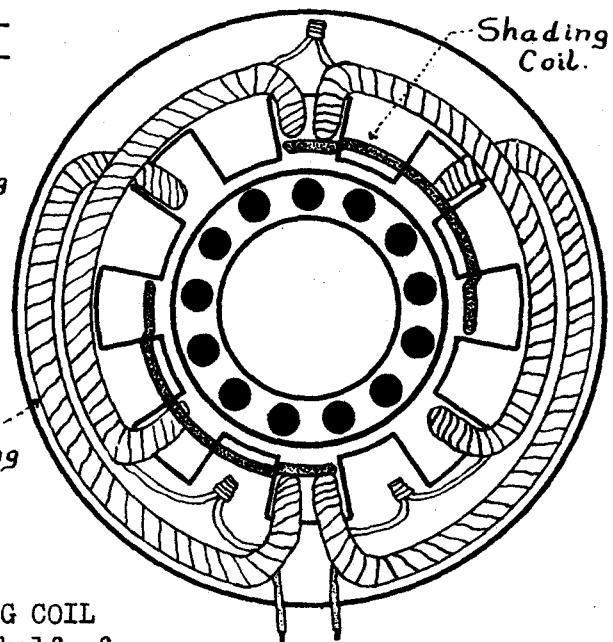
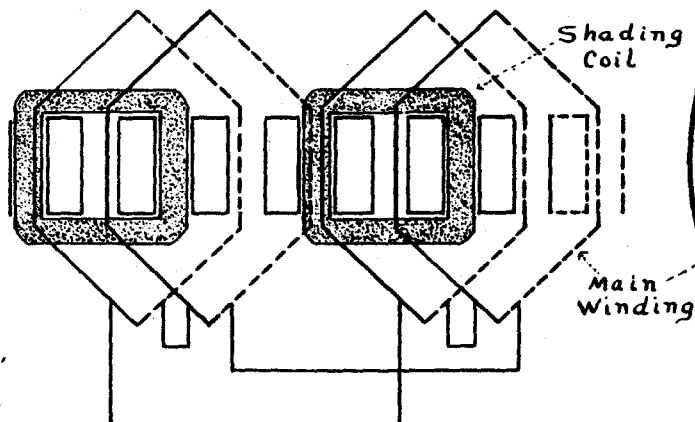

The AUXILIARY WINDING is known as the SHADING COIL and usually surrounds from one third to one half of the pole. The MAIN WINDING surrounds the entire pole and may consist of one or more coils per pole.

OPERATION: In the unshaded section of the pole, the magnetic flux produced by the main winding is in phase with the main winding current, whereas the flux produced by the shading coil is out of phase with the main flux. Thus the shading coil acts as a phase splitting device to produce the rotating field that is essential to the self-starting of all straight induction motors. As the movement of the flux across the pole face is always from the unshaded to the shaded section of the pole, the direction of rotation can be determined on the normally nonreversible motor by noting the position of the shading coil with respect to the pole itself, This type can be reversed by removing the stator from the frame, turning it through 180° and replacing it.

CHARACTERISTICS: The starting torque will not exceed 80% of full load torque at the instant of starting, increases to 120% at 90% of full speed, decreasing to normal at normal speed. This type motor operates at low efficiency and is constructed in sizes generally not exceeding one-twentieth H.P.

APPLICATION: Fans, timing devices, relays, radio dials, or in general any constant speed load not requiring high starting torque.

SHADED POLE MOTOR-2 MAIN WINDINGS: This type is externally reversible by means of a S.P.D.T. switch as shown in the lower diagram. Note that only one set of shading coils is used. Trace the circuits and establish the position of poles for both rotations.

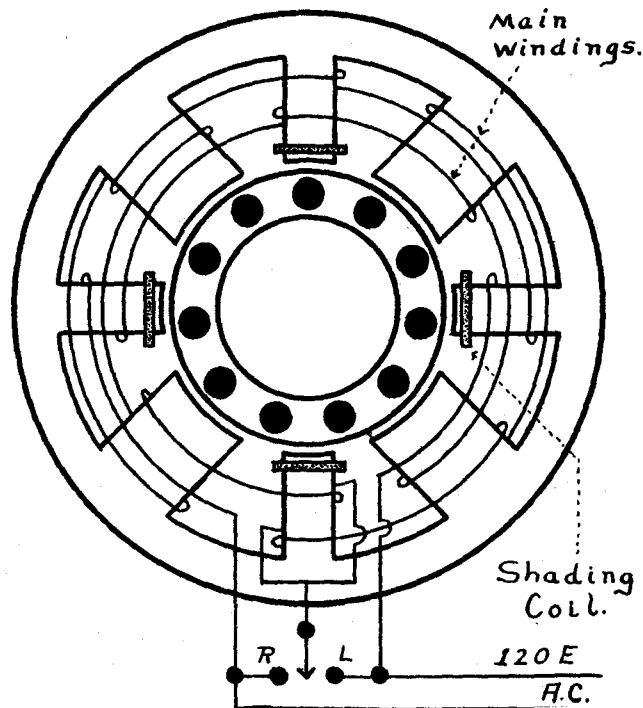

FARM MOTORS

Application and Operating Data

FRACTIONAL HORSEPOWER MOTORS

Satisfactory performance from a small general purpose motor will be assured by use of a repulsion-induction motor or a "capacitor" motor as described in the following table. These types are slightly higher in price than a split-phase motor, but pro-

vide higher starting power without imposing heavy current demands that may reduce voltage in the line and cause lights to flicker, or cause a fuse to blow because of starting overload. On the other hand, the split-phase motor will give satisfactory service for the lighter jobs such as running the washing machine, churn, small tool grinders, etc.

1. REPULSION-START INDUCTION MOTORS

Similar in performance to the larger 3, 5, 7½ horsepower motors. Sizes from ½ to ¾ horsepower, high starting power, low starting current. For use on 110-220 volt, single phase, 60-cycle circuits.

2. CAPACITOR MOTORS

For use on 110 or 220-volt single-phase service. High starting power, low starting current, high efficiency. Highly satisfactory for general purpose use. Sizes range from ½ to ¾ horsepower.

3. SPLIT-PHASE MOTORS

Inexpensive type of small motor, but requires high starting current. Suitable for washing machine, ventilating fan, small tool grinder or other uses where starting load is not heavy. Sizes, ⅓ to ½ horsepower for 110 or 220-volt service.

Machine	Hp. Most Used	RECOMMENDED MOTOR TYPE			Recommended Control
		Repulsion Induction	Split Phase	Capacitor	
Washing Machine	½ or ¼		x		Sentinel Breaker
Cream Separator	½ or ¼	x		x	Sentinel Breaker
Churn	¼		x		Sentinel Breaker
Concrete Mixer (small)	¼ or ½	x		x	Sentinel Breaker
Farm Shop Equipment	¼	x		x	Sentinel Breaker
Fanning Mill	¼		x		Sentinel Breaker
Corn Sheller (single hole)	¼	x		x	Sentinel Breaker
Fruit Grader	¼	x		x	Sentinel Breaker
Grindstone	¼		x		Sentinel Breaker
Shearing Tool	¼		x		Sentinel Breaker
Sausage Grinder	¼	x		x	Sentinel Breaker
Potato Grader	½	x		x	Sentinel Breaker
Pump Jack	½	x		x	Sentinel Breaker
Root Cutter	¼ and 1	x		x	Sentinel Breaker
Small Feed Grinder (Burr)	½ and 1	x		x	Sentinel Breaker

MINIMUM RECOMMENDED SPEEDS OF CUTTER FANS TO ELEVATE ENSILAGE

INTO SILOS OF DIFFERENT HEIGHTS USING 3-HP. MOTOR*

Diameter of Cutter Fan Inches (Wing Tip to Wing Tip)	Height of Silo in Feet								
	25'	30'	35'	40'	45'	50'	55'	60'	75'
	Recommended Fan Speed, Revolutions per Minute								
30	500	530	575	610	650	690	720	750	835
32	465	495	540	575	610	645	675	705	735
34	440	465	510	540	570	610	635	660	780
36	415	440	480	510	540	575	600	625	695
38	390	415	450	480	510	545	570	595	660
40	370	395	430	460	485	515	540	565	625
42	355	380	410	435	465	490	515	535	595
44	340	360	390	415	440	470	490	510	570
46	325	345	375	400	425	450	470	490	545
48	310	330	360	380	405	430	450	470	520

For silos higher than 40 feet, the 7½ h.p. motor is recommended.

*From Wisconsin Rural Electrification Handbook. (Published by University of Wisconsin)

MOTORS AND CONTROL

for

FARM WORK

INFORMATION SHOWING THE TYPE OF MOTOR AND CONTROL FOR VARIOUS TYPES OF MACHINERY USED ON THE FARM

Name	FARM JOB		MOTOR			CONTROL	
	Speed Recommended Rpm.	Pulley Recommended Dia. Inches	Hp. Most Used	PULLEY RECOMMENDED INCHES Dia. Face		PREFERRED Westinghouse Pushbutton Class No.	ALTERNATE Westinghouse Manual Class No.
Milking Machine† (Pipe Line Type)	800	6	1	3	2½	Sentinel Breaker††	WK-18
Refrigerator (Dairy)†	See mfrs. specification	Determine by formula	¾ or 1	3	2½	Sentinel Breaker††	WK-18
Hay Hoist	Rope speed 100-200 ft./min	Determine by formula to give correct rope speed	3 or 5	5½	6¾	WK-16†† or 11-200	10-030
Grain Elevator (Inside or outside)	See mfrs. specification	Determine by formula	3 or 5	5½	6¾	WK-16†† or 11-200	10-030
Bone Grinder	See mfrs. specification	Determine by formula	5	4½	6¾	11-200	10-030
Cider Mill (large)	See mfrs. specification	Determine by formula	5	4½	6¾	11-200	10-030
Feed Grinder Hammer Type*	3500	4	5	8	6¾	11-200	10-030
Burr Type	800	12	5	5½	6¾	11-200	10-030
Feed Mixer	See mfrs. specification	Determine by formula	5	5½	6¾	11-200	10-030
Grain Blower Elevator*	3500	4	5	8	6¾	11-200	10-030
Wood Saw	1300	6	5	4½	6¾	11-200	10-030
Ensilage Cutter	SEE PRINT No. 243	Determine by formula	5 or 7½	4½	6¾	11-200	10-030
Hay Baler	600	16	5 or 7½	5½	6¾	11-200	10-030
Spraying Plant (Stationary)	600	13	5 or 7½	4½	6¾	11-200	10-030
Husking and Shredding Corn	See mfrs. specification	Determine by formula	5 or 7½	4½	6¾	11-200	10-030
Irrigation	Depends on conditions and capacity of pump. See manufacturers requirements.						

* If an individual motor is justified for these machines, it may be desired to use a 3450-Rpm. motor direct connected to eliminate pulleys and belts. † Would generally be permanently installed. †† These are manual starters.

MOTOR PULLEY DIAMETER

Dia. of Pulley on Driven Machine	APPROX. RPM. OF DRIVEN MACHINE WITH FULL LOAD MOTOR SPEED OF 1750 RPM					
	3½"	4½"	5½"	7"	8"	9"
3"	2040	2580	3140	4000
4"	1530	1930	2360	3000	3500	3950
5"	1225	1540	1880	2400	2800	3150
6"	1020	1290	1570	2000	2340	2620
8"	765	965	1175	1500	1750	1970
10"	612	770	940	1200	1400	1575
12"	510	640	785	1000	1170	1310
14"	437	550	670	860	1000	1120
16"	383	480	580	750	880	990
18"	340	430	520	670	780	880
20"	306	385	470	600	700	790
22"	278	350	430	550	640	720
24"	255	320	390	500	580	660

FORMULA FOR FIGURING PULLEY SIZES AND SPEEDS

For machine speeds and pulley sizes not covered in the tables, the following simple formula may be used.

$$\text{Machine Pulley Diameter} = \frac{\text{Motor Pulley diameter} \times \text{Motor Rpm.}}{\text{Machine Rpm.}}$$

(Pulley diameters should be figured in inches)

For example, the motor pulley is 8 inches in diameter. The motor speed is 1750 revolutions per minute. It is desired to operate a hammer mill at 3500 rpm. What size pulley should be used on the mill?

Using the formula, we get:

$$\text{Hammer Mill Pulley Diameter} = \frac{8 \times 1750}{3500} = 4 \text{ inches}$$

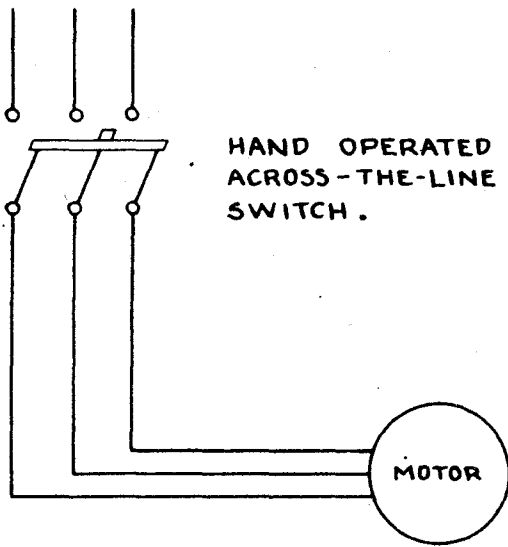

HAND OPERATED ACROSS-THE-LINE SWITCH.

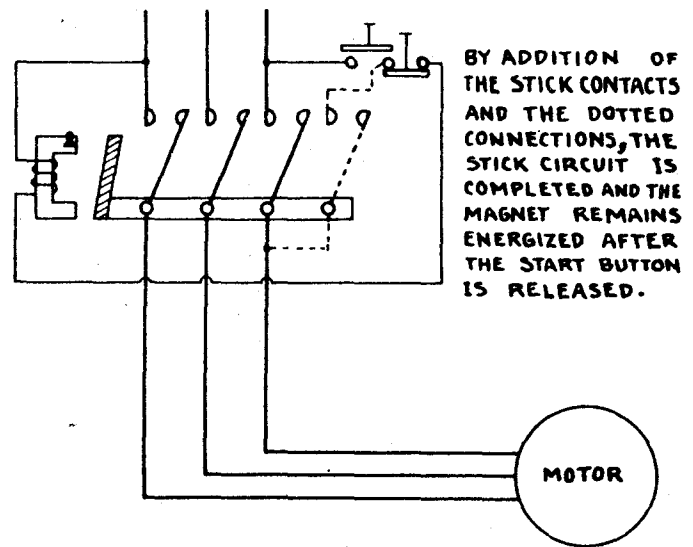

BY ADDITION OF THE STICK CONTACTS AND THE DOTTED CONNECTIONS, THE STICK CIRCUIT IS COMPLETED AND THE MAGNET REMAINS ENERGIZED AFTER THE START BUTTON IS RELEASED.

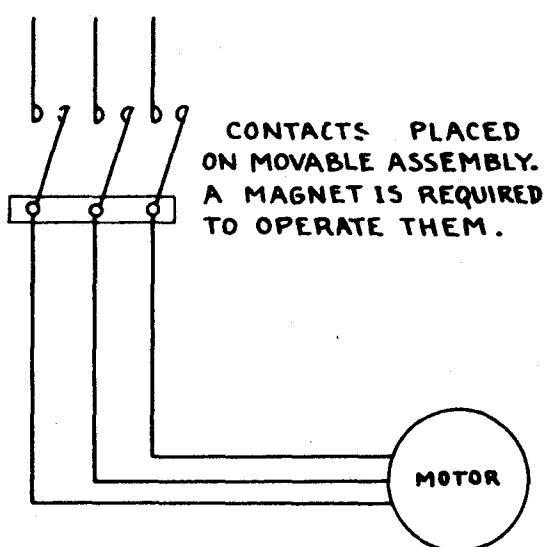

CONTACTS PLACED ON MOVABLE ASSEMBLY. A MAGNET IS REQUIRED TO OPERATE THEM.

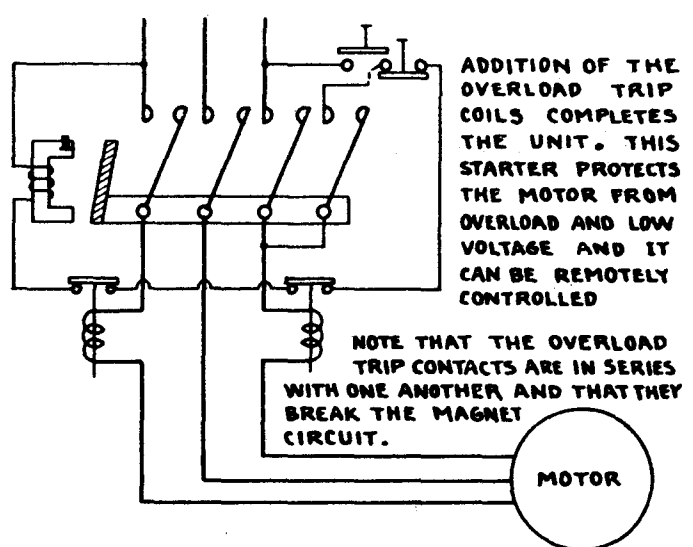

ADDITION OF THE OVERLOAD TRIP COILS COMPLETES THE UNIT. THIS STARTER PROTECTS THE MOTOR FROM OVERLOAD AND LOW VOLTAGE AND IT CAN BE REMOTELY CONTROLLED

NOTE THAT THE OVERLOAD TRIP CONTACTS ARE IN SERIES WITH ONE ANOTHER AND THAT THEY BREAK THE MAGNET CIRCUIT.

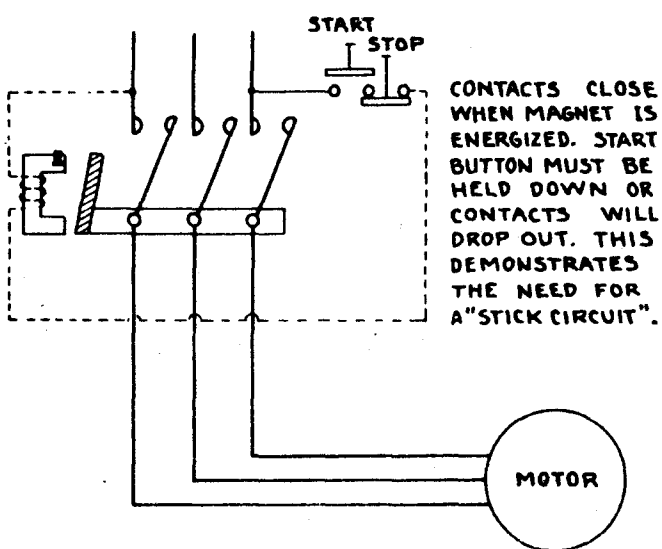

CONTACTS CLOSE WHEN MAGNET IS ENERGIZED. START BUTTON MUST BE HELD DOWN OR CONTACTS WILL DROP OUT. THIS DEMONSTRATES THE NEED FOR A "STICK CIRCUIT".

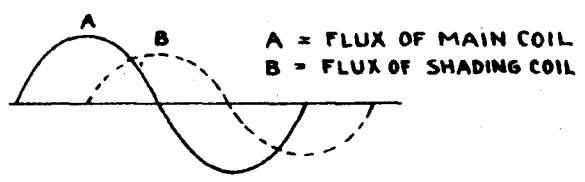
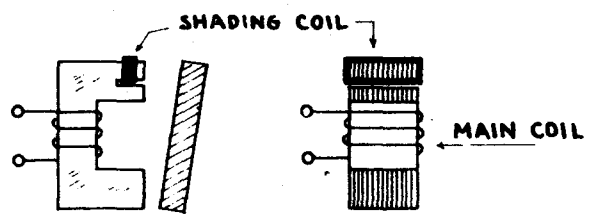

A = FLUX OF MAIN COIL
B = FLUX OF SHADING COIL

THE SHADING COIL IS USED TO PREVENT VIBRATION OF THE MAGNET ARMATURE, DUE TO PULSATIONS IN THE PULL CAUSED BY THE MAGNETIC FLUX FALLING TO ZERO TWICE PER CYCLE. AS SHOWN BY THE CURVES, THE SHADING COIL SETS UP A FLUX IN THE POLE FACE 90° OUT OF PHASE WITH THE FLUX OF THE MAIN COIL, THEREBY PRODUCING A PULL ON THE ARMATURE AT ALL TIMES.

DEVELOPMENT OF AN ACROSS-THE-LINE STARTER

ALLEN BRADLEY

ACROSS THE LINE AUTOMATIC MOTOR STARTING SWITCH. TYPE "A".

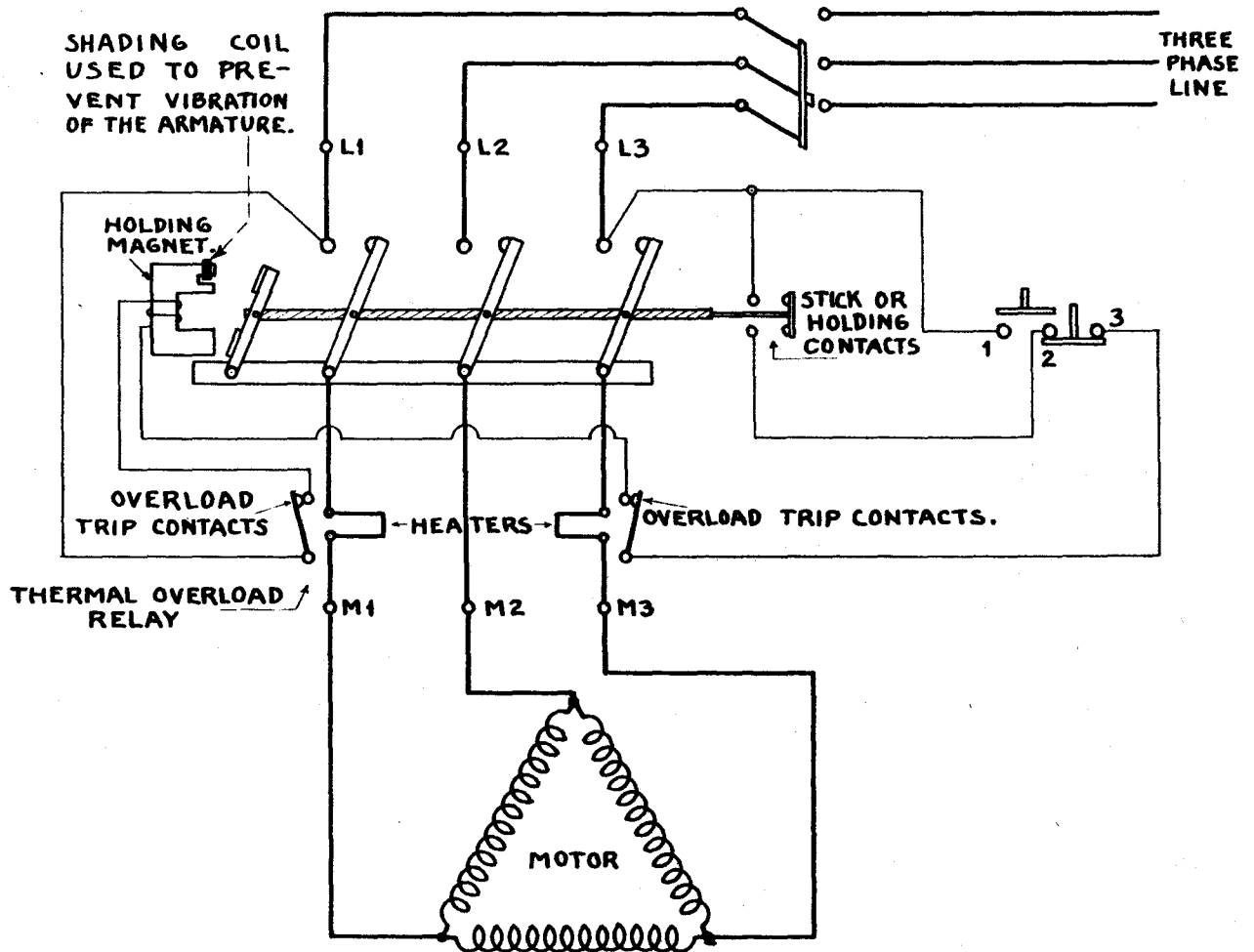

COYNE ELECTRICAL SCHOOL.

WHEN AN OVERLOAD OCCURS THE HEATER MELTS THE SOLDER WHICH ALLOWS THE ARM "A" TO MOVE UPWARD OPENING OVERLOAD TRIP CONTACTS.

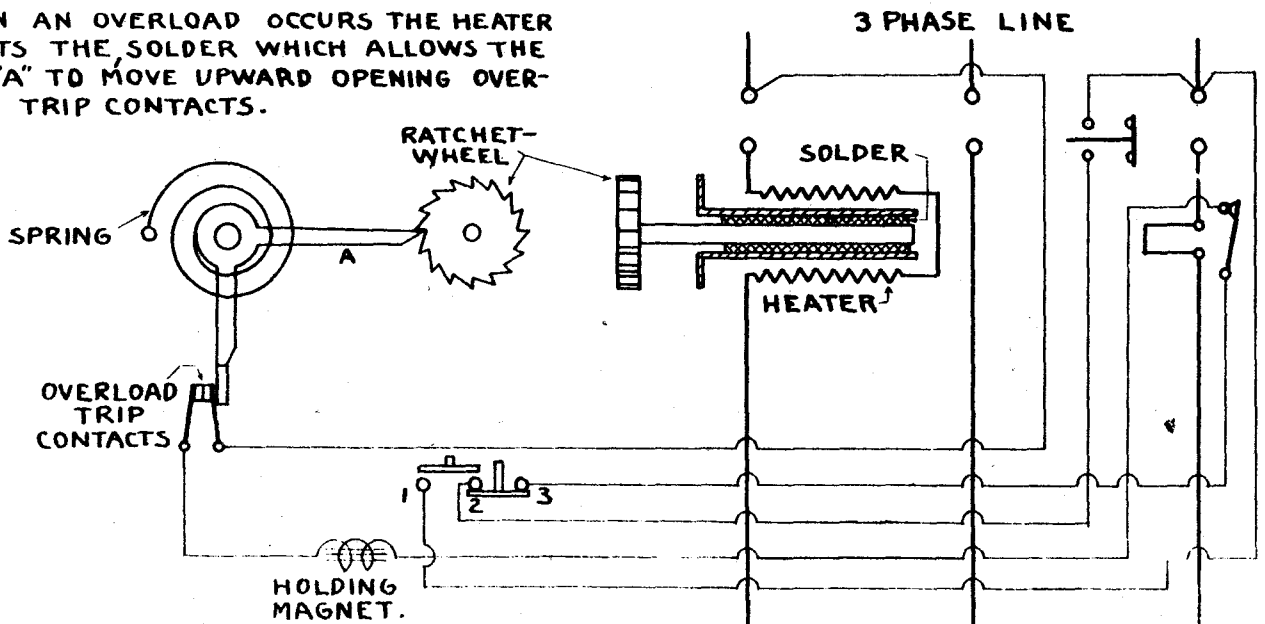

WIRING DIAGRAMS



CLASS 8501

A. C. MAGNETIC RELAYS

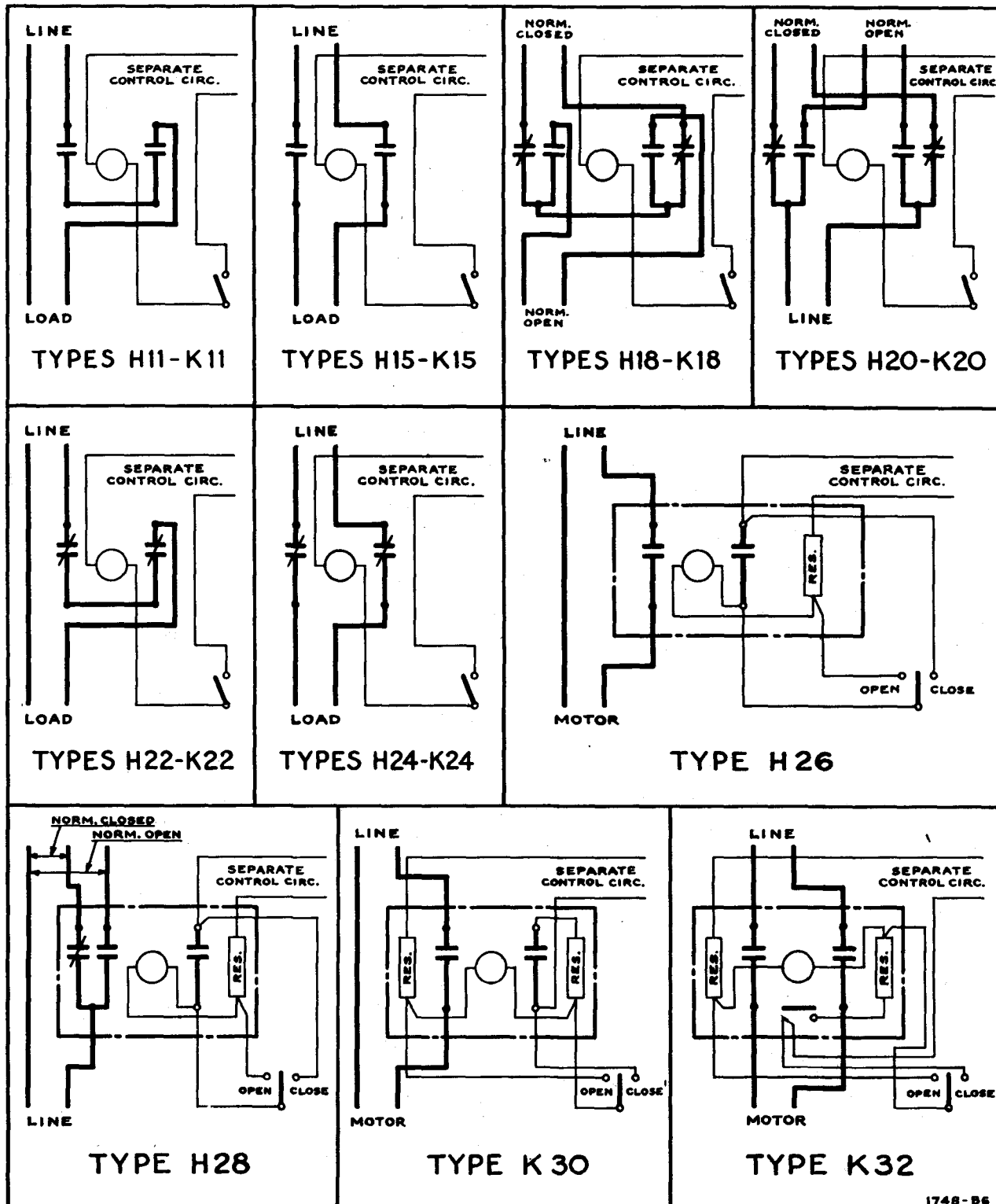

1748-B6

GENERAL ELECTRIC MAGNETIC SWITCH

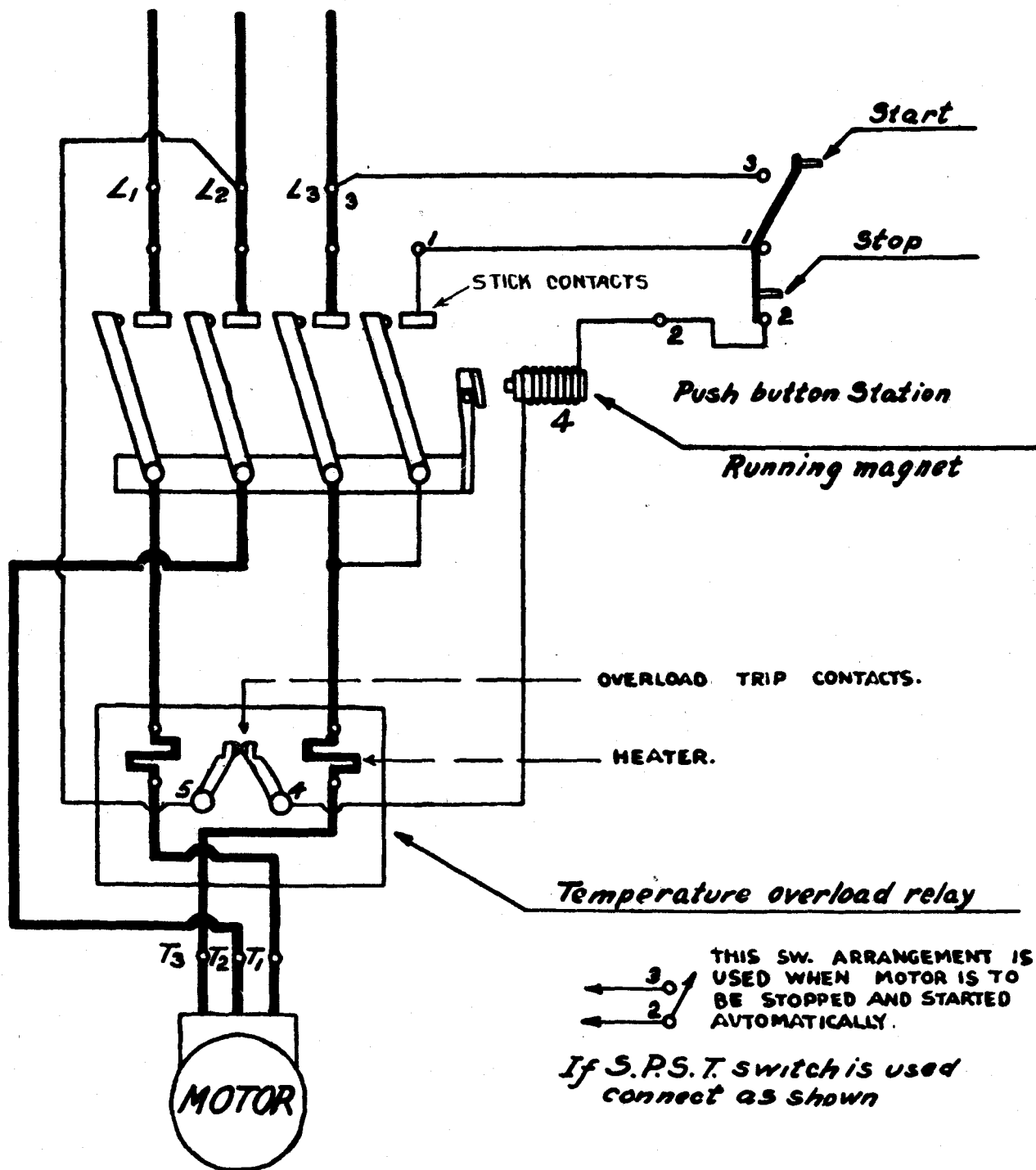

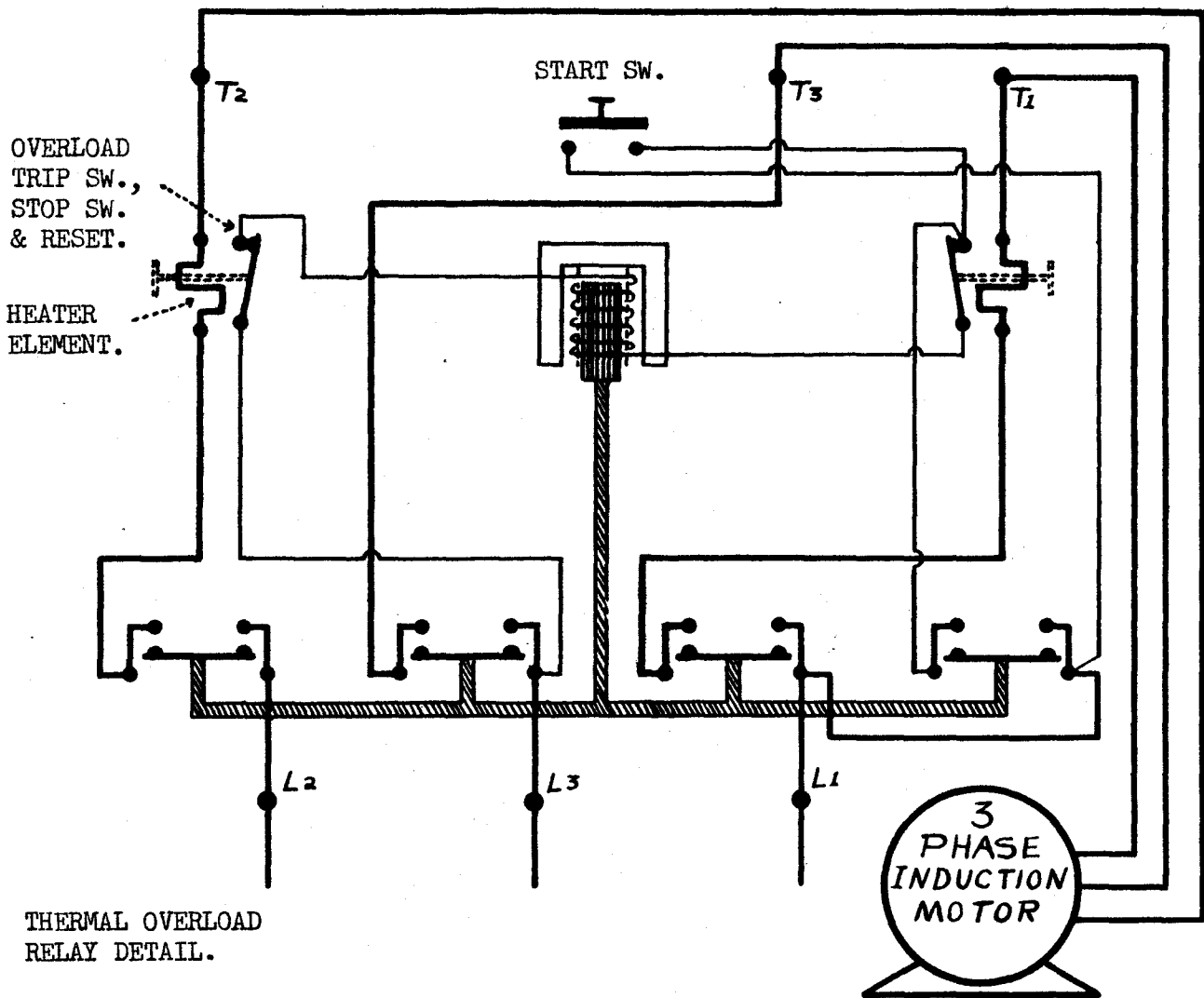

THERMAL OVERLOAD RELAY DETAIL.

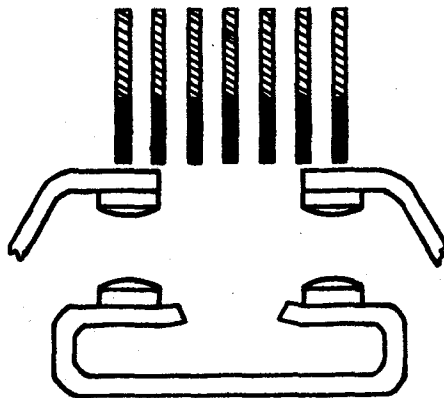
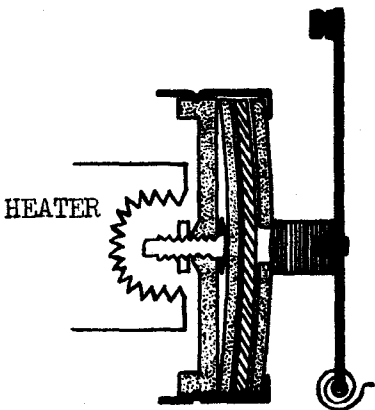

"DE-ION" ARC QUENCHER.

As the contacts separate, the specially shaped moving contact gives a magnetic reaction that forces the arc into the "DE-ION" grids where it is sliced into a series of arcs. At the next zero point on the I cycle, the air adjacent to each grid is deionized, and the arc is put out.

The bi-metal diaphragm consists of a soft metal disc such as brass (shaded with diagonal lines) placed between 2 steel discs of diaphragm steel. The adjusting screw, which is supported by a steel bridge, conducts the heat to the bi-metal diaphragm. The brass expands more rapidly than the steel with a rise in temperature. If the screw is properly adjusted, the diaphragm center will move toward the overload trip switch and open it, interrupting the magnet circuit, thus releasing the motor from the supply when an overload occurs. Thermal overload releases usually require resetting by hand.

FRONT VIEW DIAGRAM

90041 DI

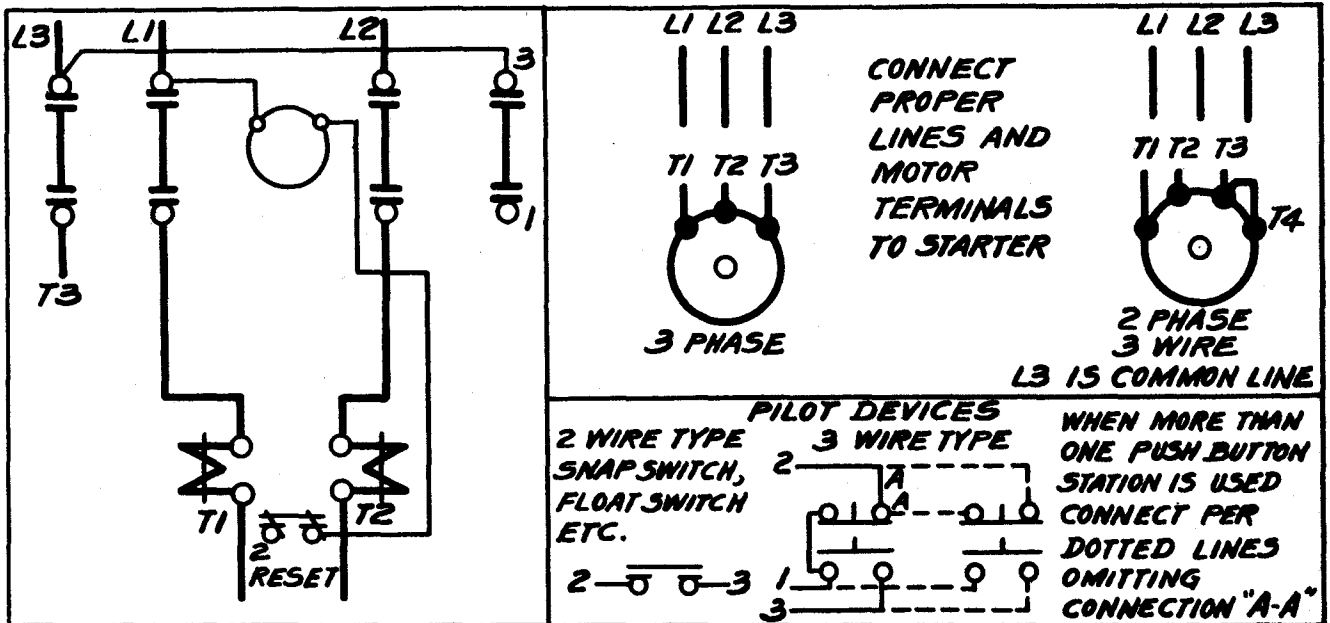

TITLE CONNECTIONS FOR A.C. AUTOMATIC STARTER WITH #489 OVERLOAD WITH RESET

DRAWN BY <i>[Signature]</i>	TRACED BY	TYPE AAA3	SUP. NO.
CHECKED <i>[Signature]</i>	APPROVED BY <i>[Signature]</i>	BULL. NO. 9586	SUP. BY NO.

A	B	C	D	ORDER NO. DEV. 4048-10
---	---	---	---	----------------------------------

CUTLER-HAMMER, INC. MILWAUKEE  NEW YORK

90041 DI

WIRING DIAGRAMS



CLASS 8536

A. C. LINE VOLTAGE MAGNETIC STARTERS—TWO AND THREE PHASE

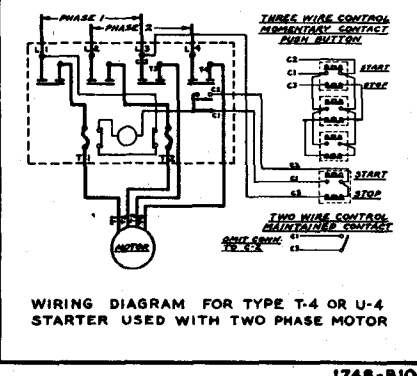
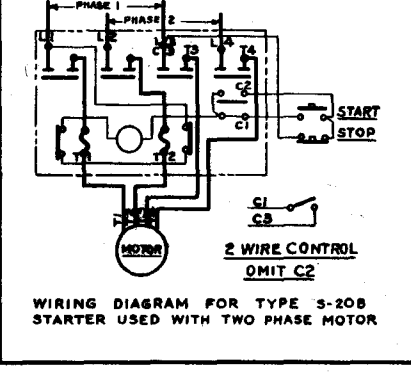
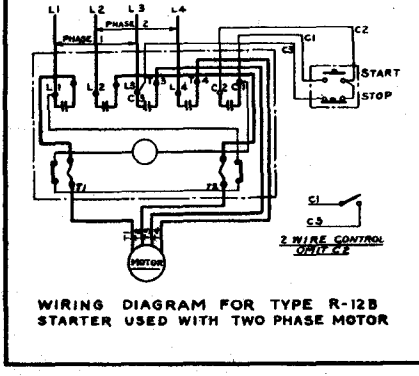
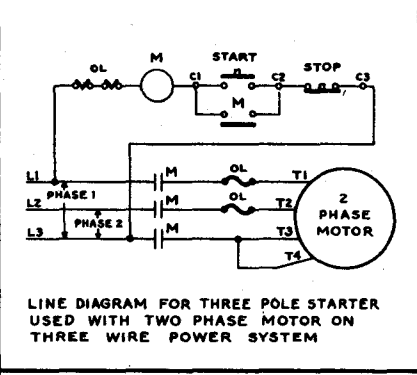
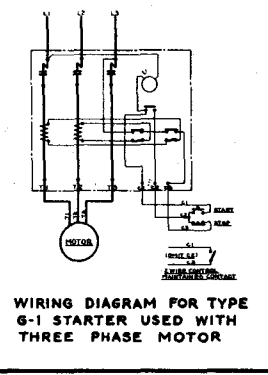
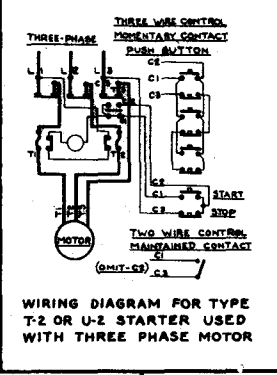
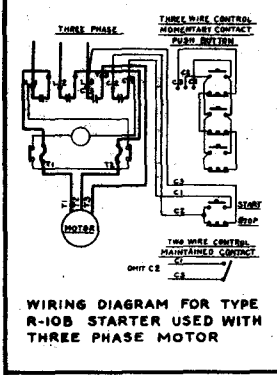
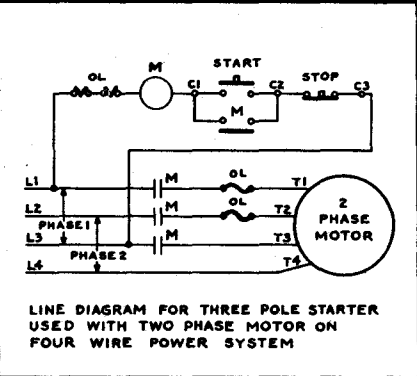
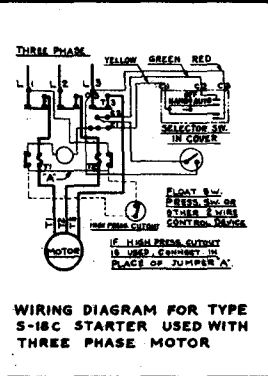
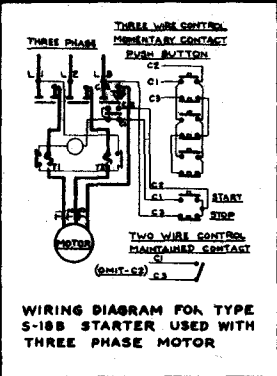
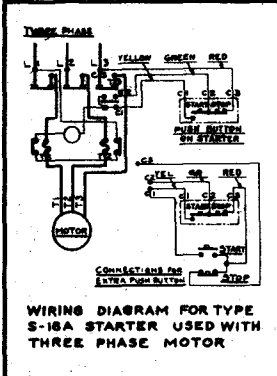
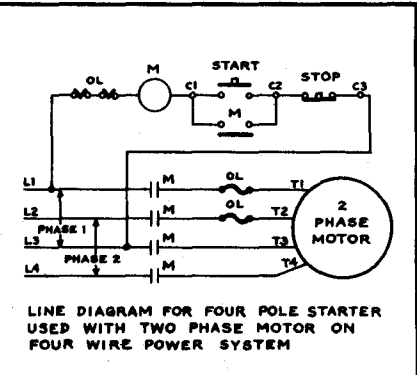
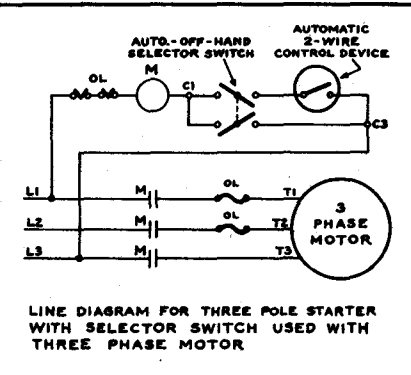
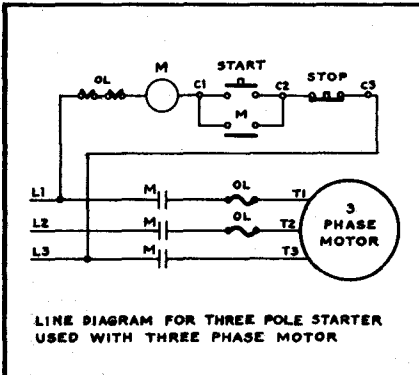

1748-B10



WIRING DIAGRAMS

A. C. LINE VOLTAGE MAGNETIC STARTERS—SINGLE PHASE

CLASS 8536

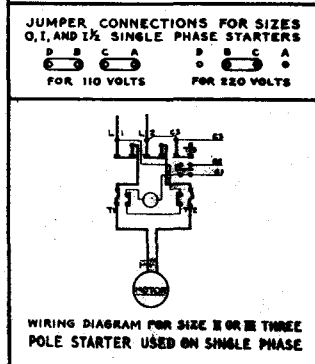
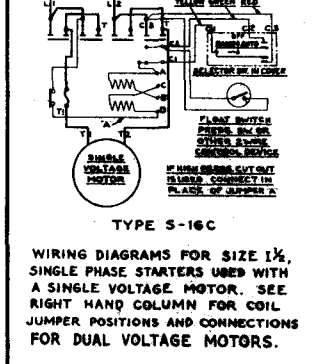
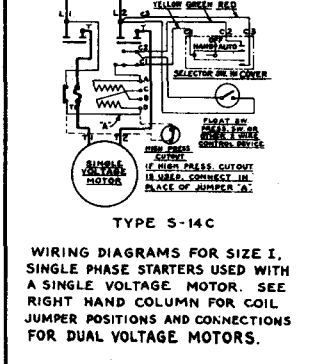
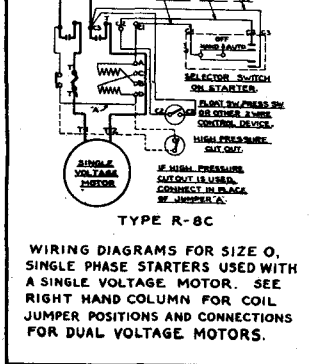
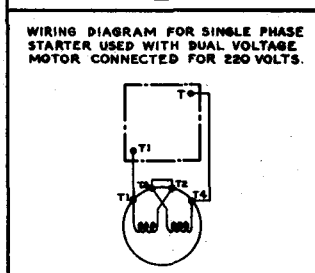
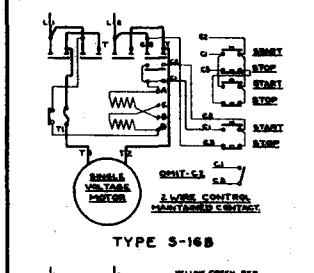
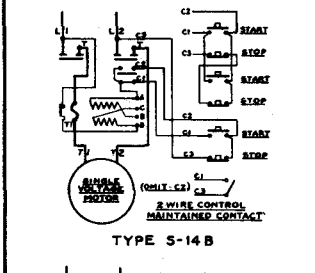
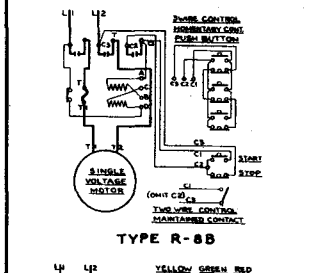
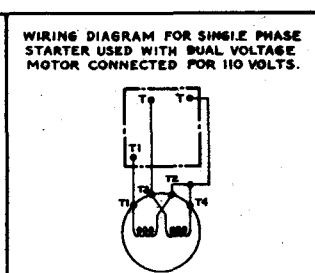
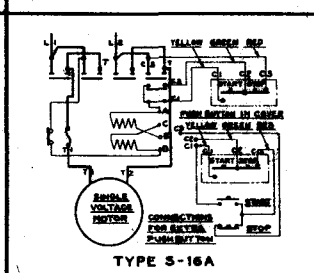
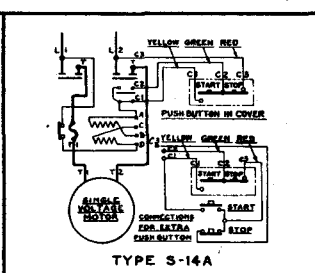
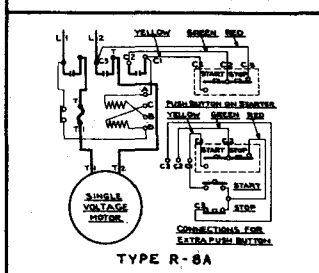
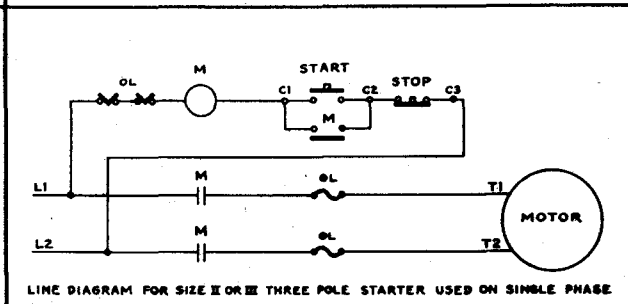
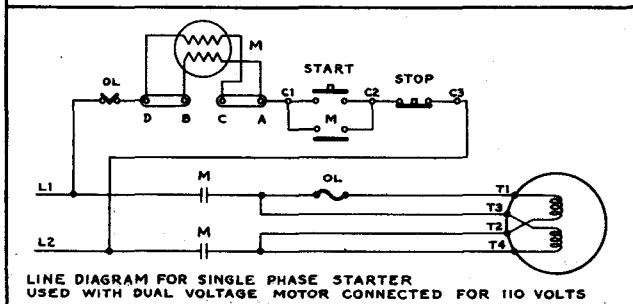
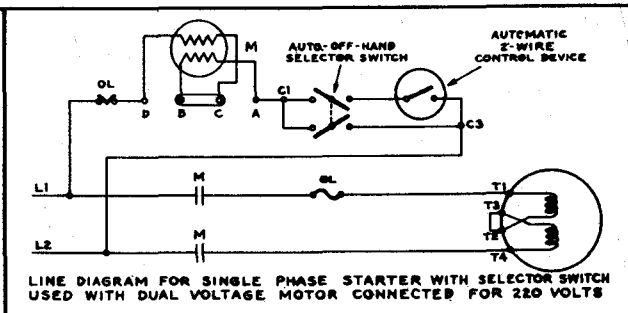
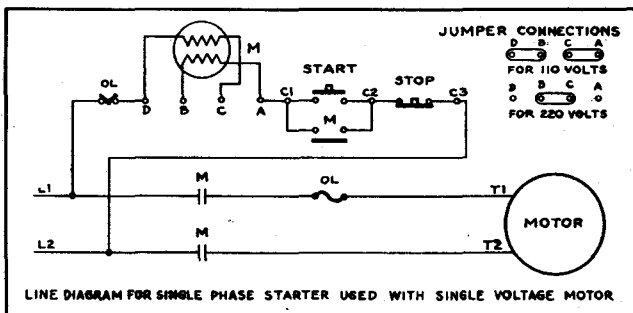

WESTINGHOUSE ACROSS THE LINE STARTER WITH PHOTO CELL CONTROL

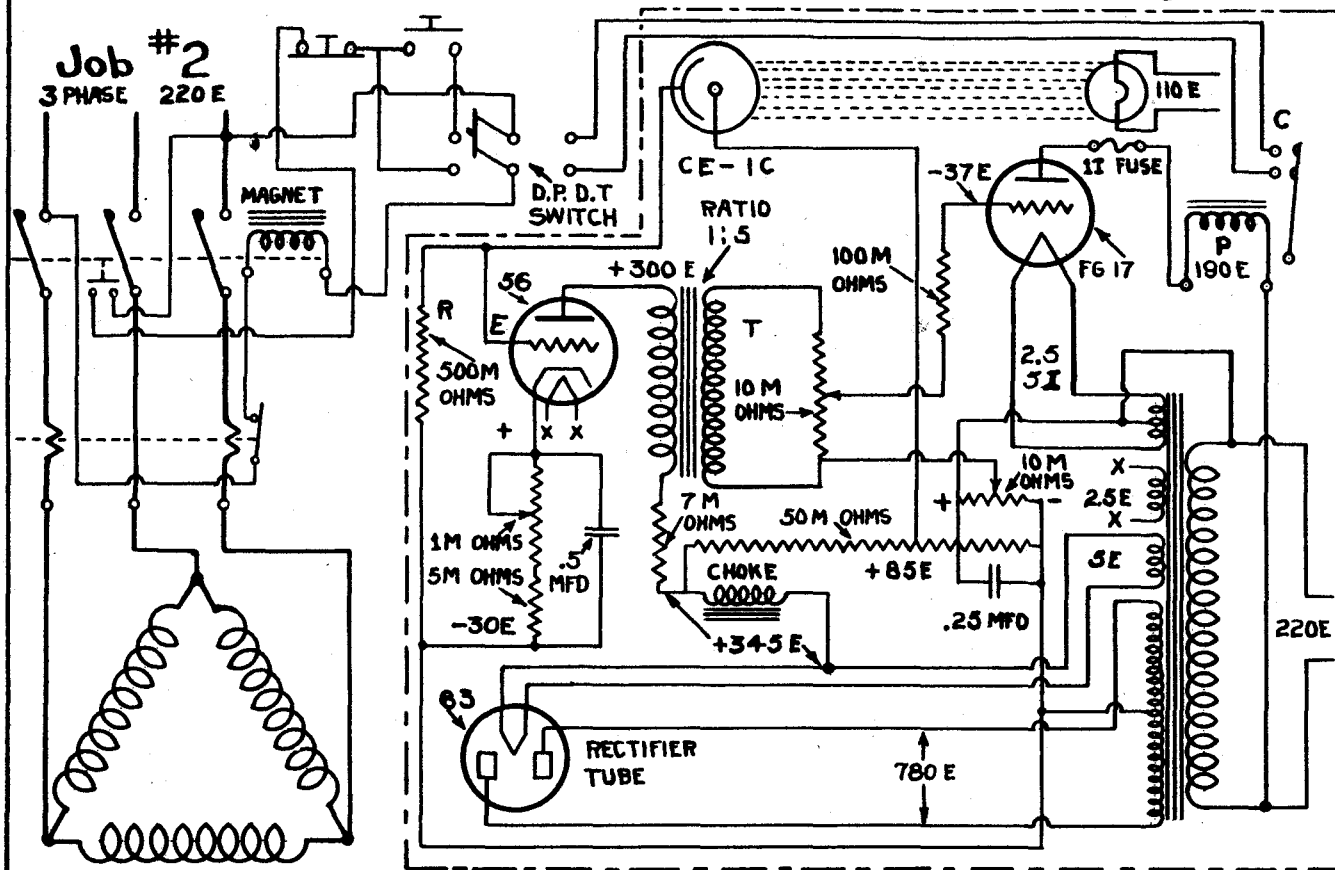

PHOTO-CELL CONTROL

In the operation of electrical equipment there are many situations where direct electrical connections between the operating apparatus and the point of control is undesirable, it is under such circumstances that photo-cell controls are frequently used, and this job demonstrates such an application. When considering the operation of such controls, it will aid the understanding to think of the photo-cell merely as a light-operated switch - as a switch which completes a circuit whenever a sufficient quantity of light falls upon it.

The control shown above employs a Type 83 tube as a full-wave rectifier to supply the necessary D.C. voltages, a Type CE-1C Cetron photo-cell tube as the light-operated switch, a Type 56 tube to amplify the minute current carried by the photo-cell, and an FG-17 Thyatron tube to complete or interrupt the circuit for the power relay "P". The Thyatron is a mercury-vapor, grid-controlled tube of relatively high current carrying capacity. The photo-cell is equipped with a centrally-located anode, and a caesium oxide-coated cathode which has the characteristic of emitting electrons wherever light falls upon it - these electrons constitute the photo-cell current.

When a beam of light falls on the photo-cell cathode, the positively charged anode (85 volts D.C.) attracts the emitted electrons and the tube conducts a current of about 100 micro-amperes which, flowing through resistor "R", raises the potential of grid of the 56 tube, causing its plate current to increase, and the increase in current induces a voltage in the secondary winding of coupling transformer "T" which drives the grid of the Thyatron more positive, with the result that it conducts and allows current to flow through relay "P". The relay contacts close and complete the circuit for magnet "M" which operates the controller.

When the light beam is interrupted, current ceases to flow through the photo-cell and resistance "R", with the result that the potential of point "E" falls, thereby reducing the plate current of the 56 tube. This reduction in current induces a voltage in the secondary winding of the coupling transformer of a polarity opposite to that produced before, and by lowering the negative potential on the grid, enables the tube to regain control and de-energize "P". Contacts "C" open the main controller contacts drop out to stop the motor.

ALLEN BRADLEY SEMI-AUTOMATIC RESISTANCE STARTER TYPE H-1852

H.P.: 5 VOLTS: 220 PHASE: 3
CYCLE: 60 NO: 116306

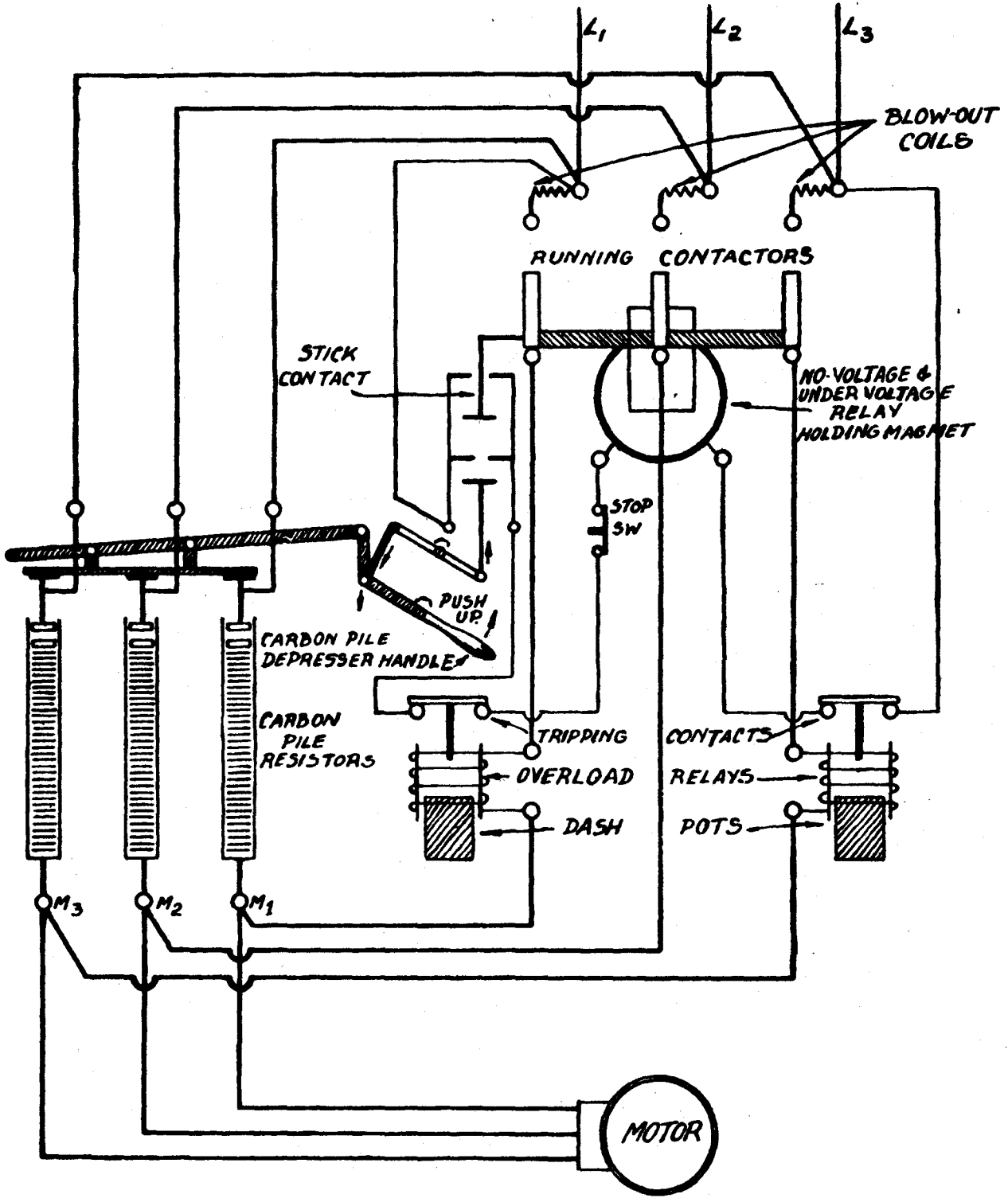

ALLEN BRADLEY TYPE J 3052 AUTOMATIC RESISTANCE STARTER 3 PHASE

S.M. STARTING MAGNET R.M. RUNNING MAGNET
S.M. & R.M. ARE UNDERVOLTAGE RELAYS

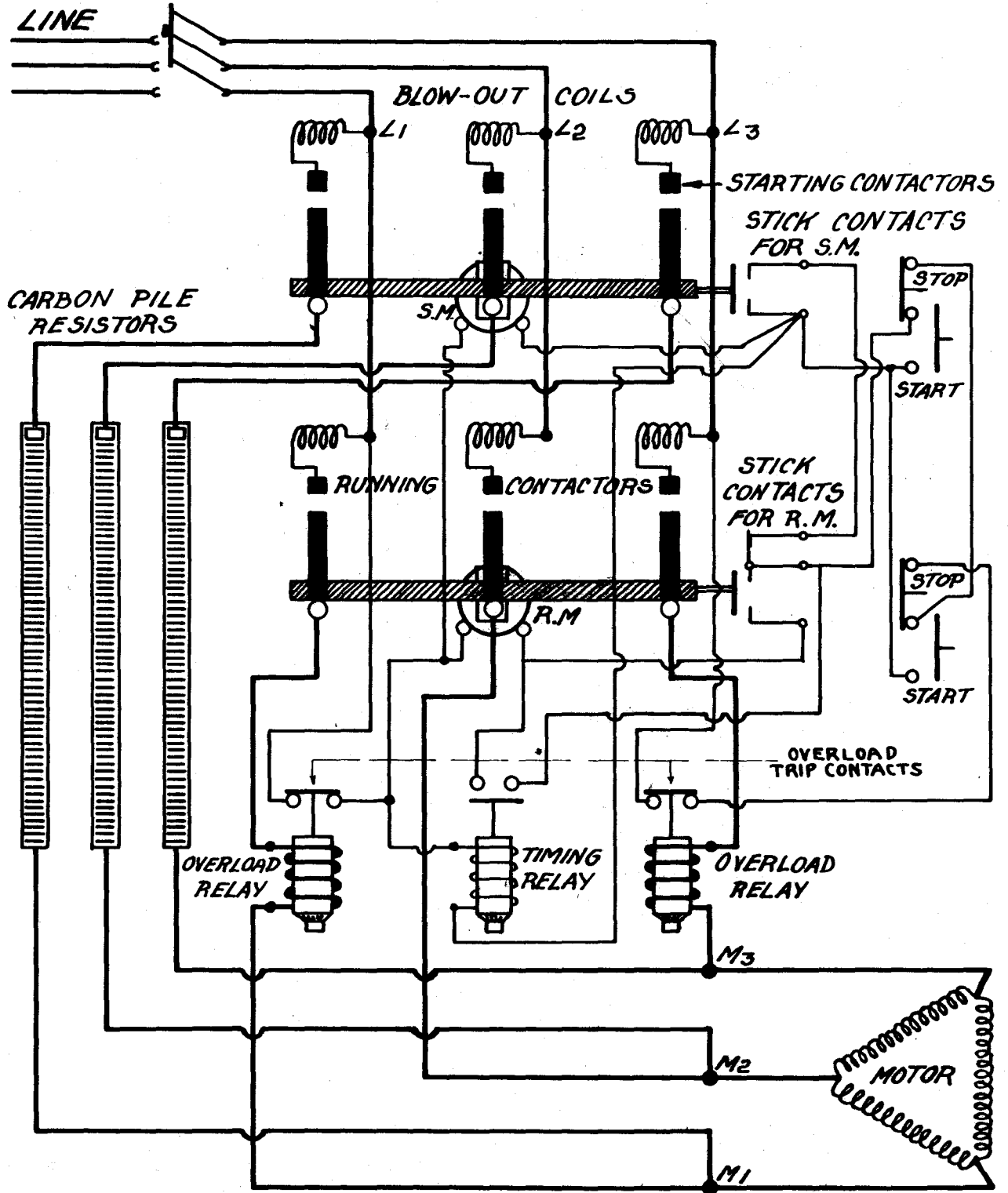

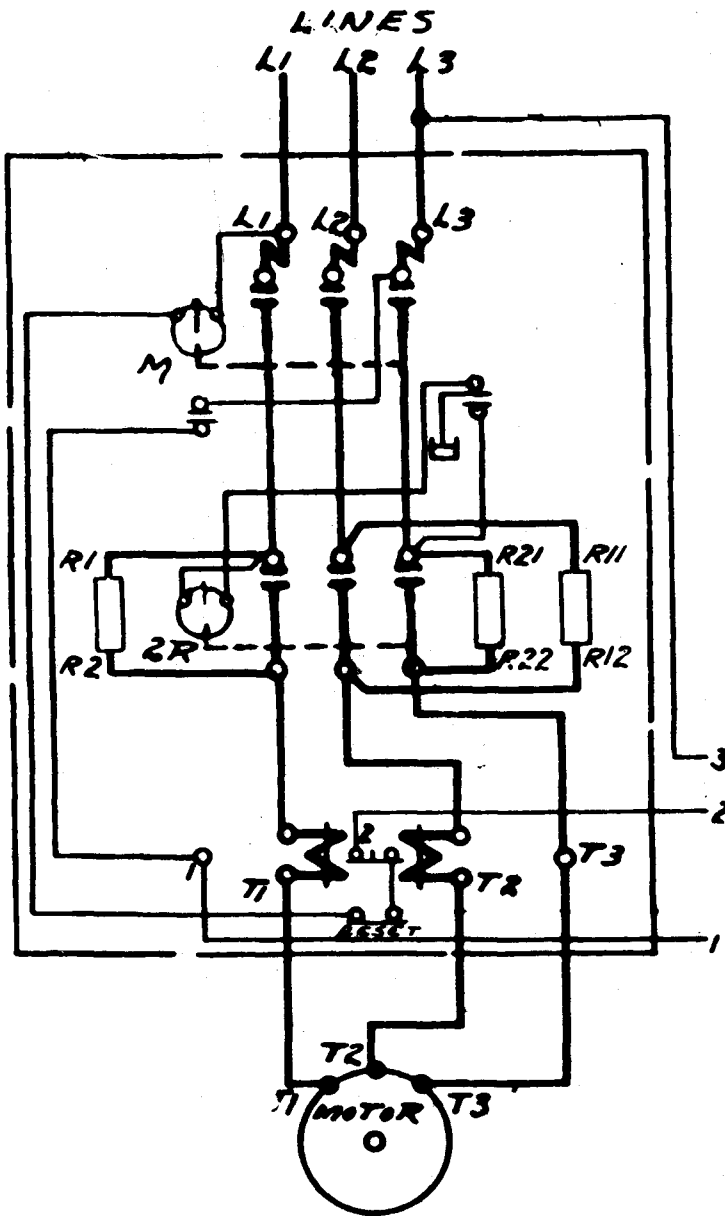

2 WIRE PILOT DEVICE

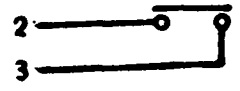

3 WIRE PILOT DEVICE

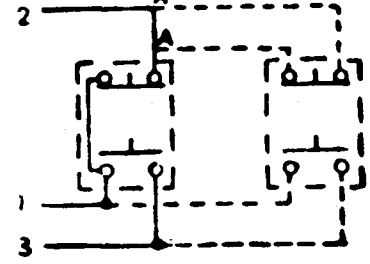

WHEN MORE THAN ONE
PUSH BUTTON STATION IS
USED CONNECT PER
DOTTED LINES OMITTING
CONNECTION "A-A".

CONNECTIONS FOR PRIMARY RESISTOR AUTOMATIC STARTER

DRAWN BY <i>J. Baird</i>		TRACED BY	TYPE	SUR NO 65727D1
CHECKED BY <i>E. Morris</i>		APPROVED BY <i>J. Baird</i> 1-14-37	BULL NO.	SVP M9 BY
A	B	C	OPER. NO. DEV. 3701-10	80091 DI
CUTLER-HAMMER INC MILWAUKEE NEW YORK				



WIRING DIAGRAMS

A. C. REDUCED VOLTAGE STARTERS—PRIMARY RESISTOR TYPE

CLASSES 8547, 8747

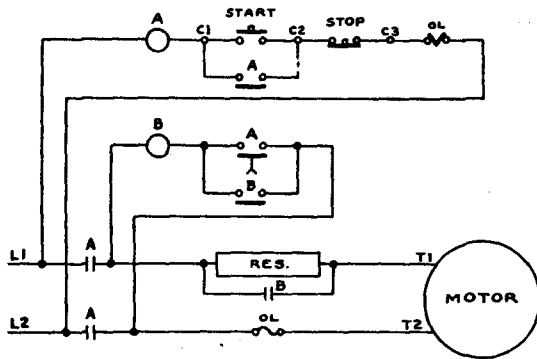

TYPICAL LINE DIAGRAM FOR CLASS 8547 SINGLE PHASE, NON-REVERSING PRIMARY RESISTOR TYPE STARTER

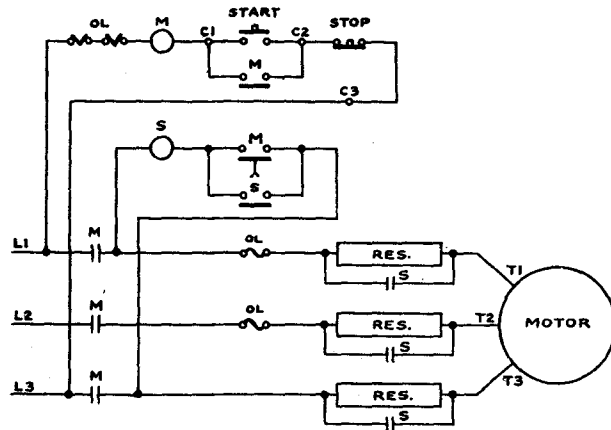

TYPICAL LINE DIAGRAM FOR CLASS 8547 THREE PHASE, NON-REVERSING PRIMARY RESISTOR TYPE STARTER

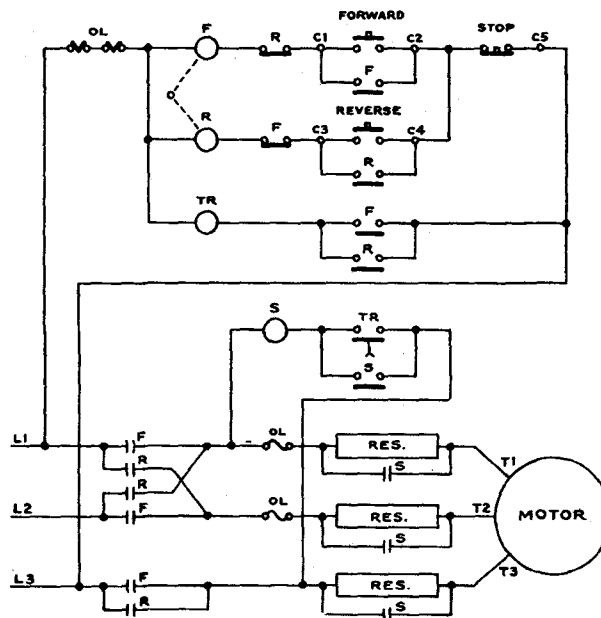

TYPICAL LINE DIAGRAM FOR CLASS 8747 THREE PHASE, REVERSING PRIMARY RESISTOR TYPE STARTER



WIRING DIAGRAMS

CLASS 8550, 8750

SECONDARY RESISTOR TYPE REDUCED VOLTAGE STARTERS

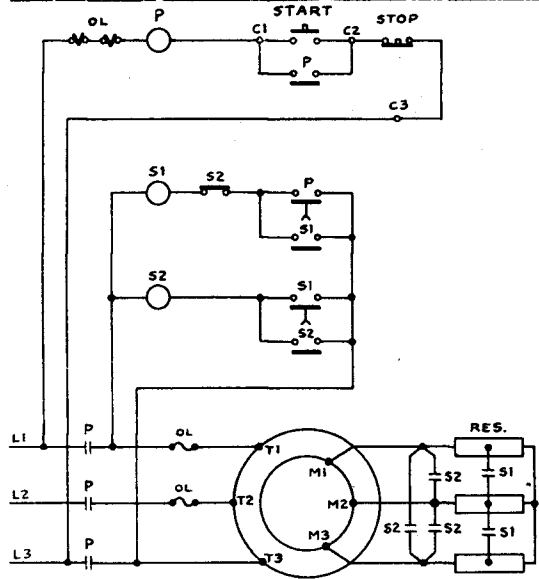

TYPICAL LINE DIAGRAM FOR CLASS 8550 NON-REVERSING WOUND ROTOR MOTOR STARTER WITH THREE POINTS OF ACCELERATION.

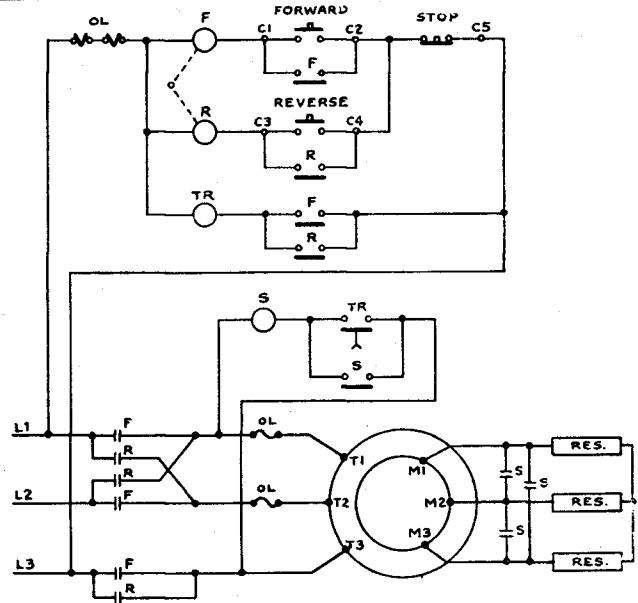

TYPICAL LINE DIAGRAM FOR CLASS 8750 REVERSING WOUND ROTOR MOTOR STARTER WITH TWO POINTS OF ACCELERATION.

1748-B8

CLASS 8606

A. C. AUTOMATIC COMPENSATORS

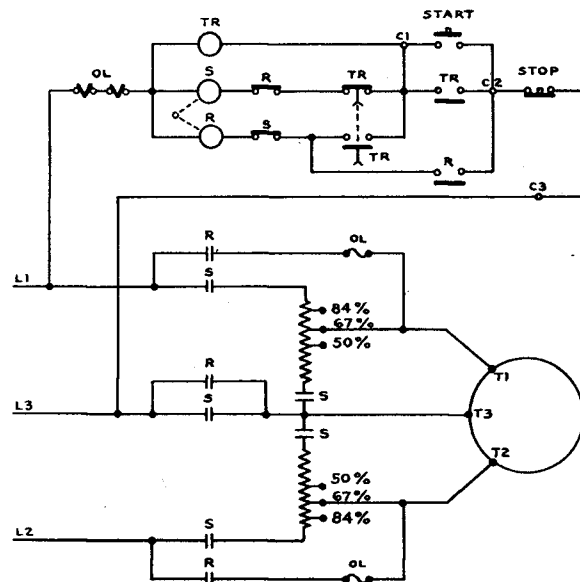

TYPICAL LINE DIAGRAM FOR CLASS 8606 AIR BREAK TYPE A.C. MAGNETIC COMPENSATOR

1748-B8

No changes since previous issue.

PRINCIPLES OF AUTO-TRANSFORMER STARTERS

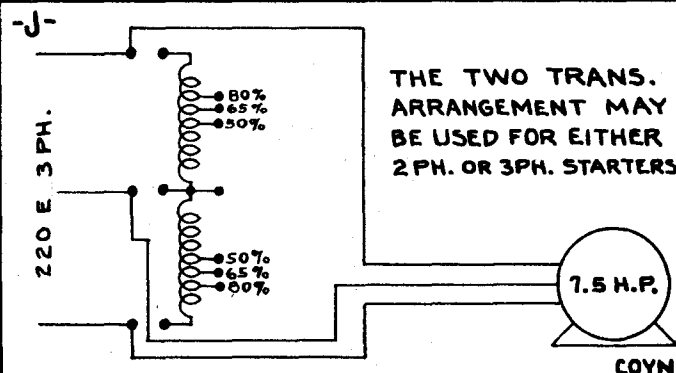
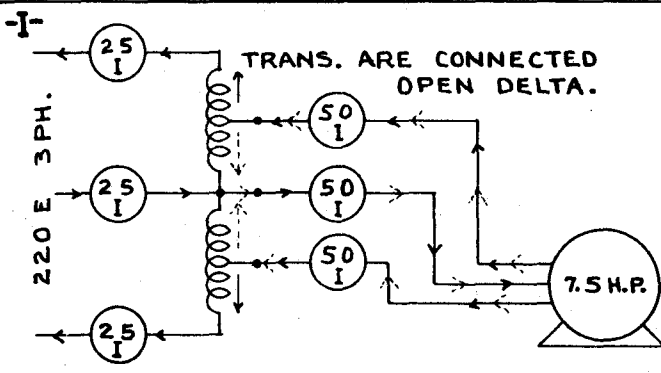
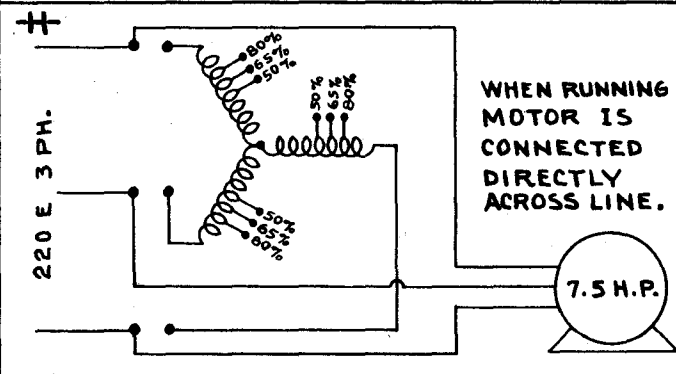
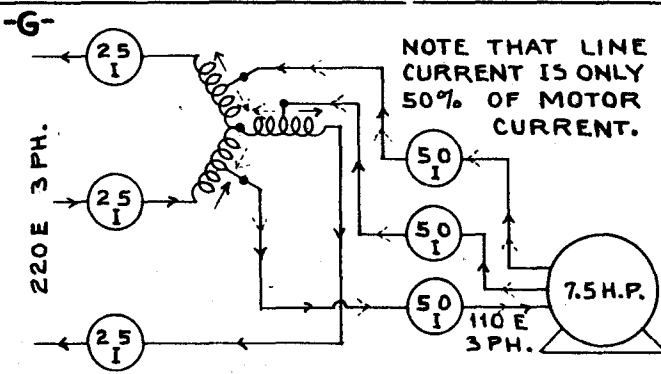
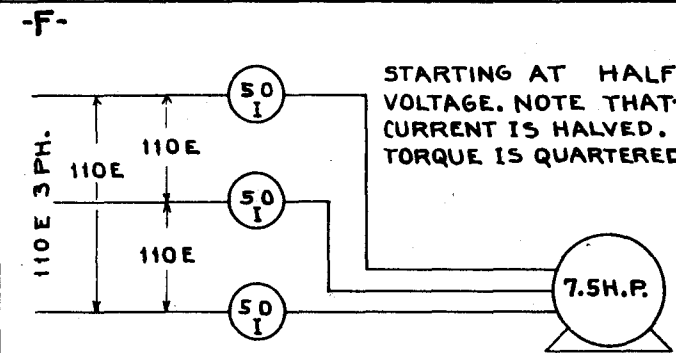
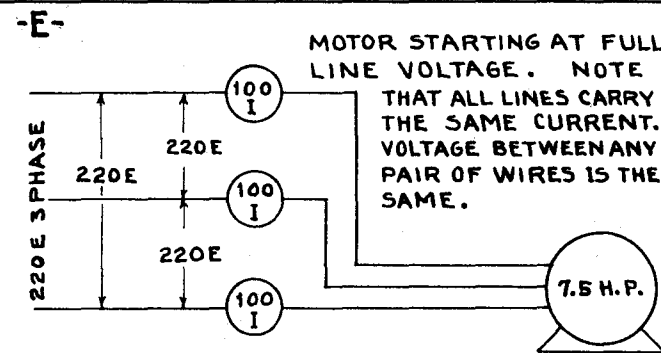
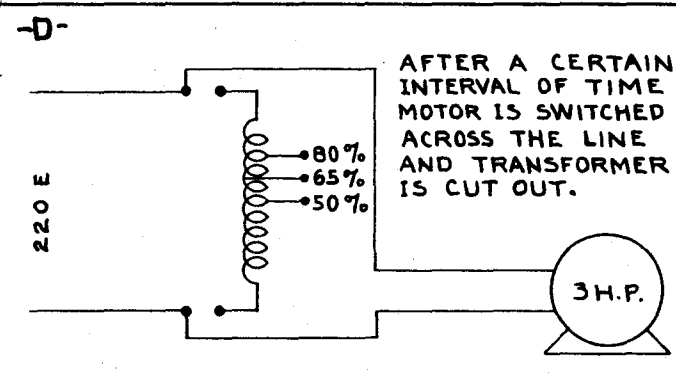
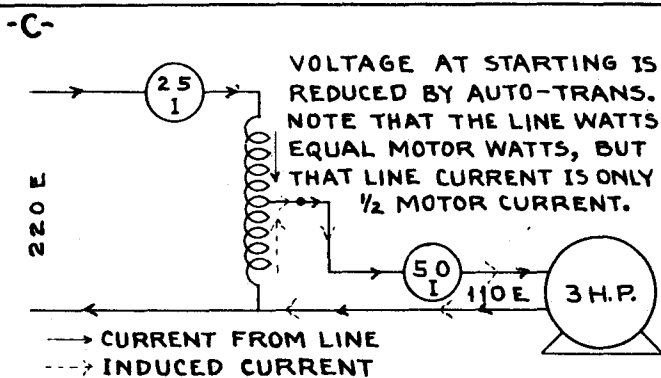
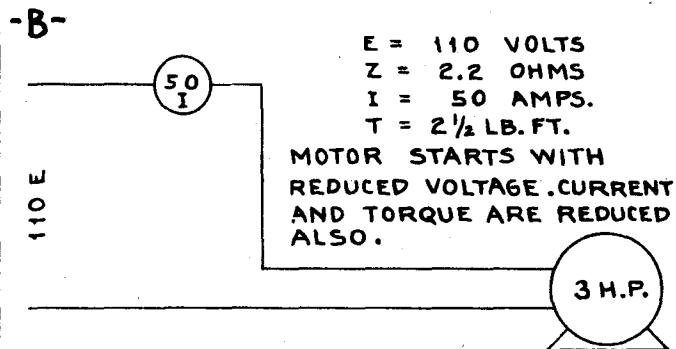
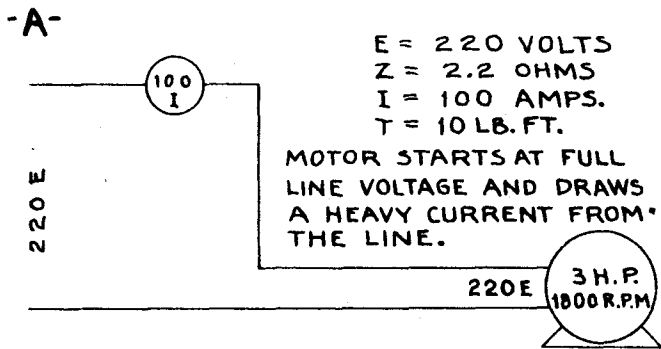

WESTERN ELECTRIC AUTO STARTER
NO. K. 971
CR-1034 TYPE NR1610 FORM H3-P1
VOLTS PRI. 220 SEC. 110-175
TYPE I FORM K HP. 10
CYCLES 60 3 PHASE

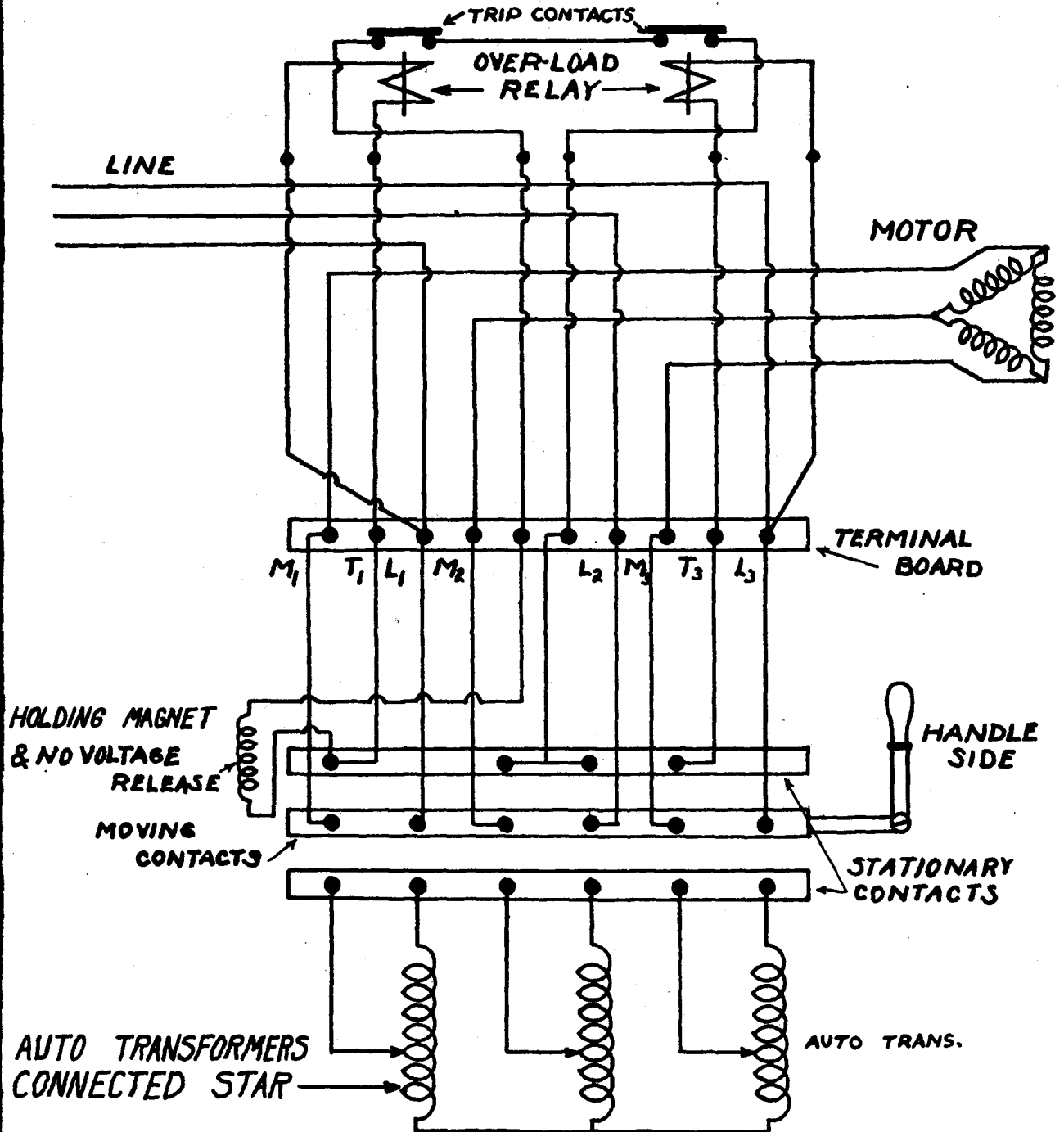

WESTINGHOUSE
 ELECTRIC & MFG. CO.
 LIIB AUTO STARTER
 5-15 H.P. 220 VOLTS 60CYCLES
 STYLE N° 185156

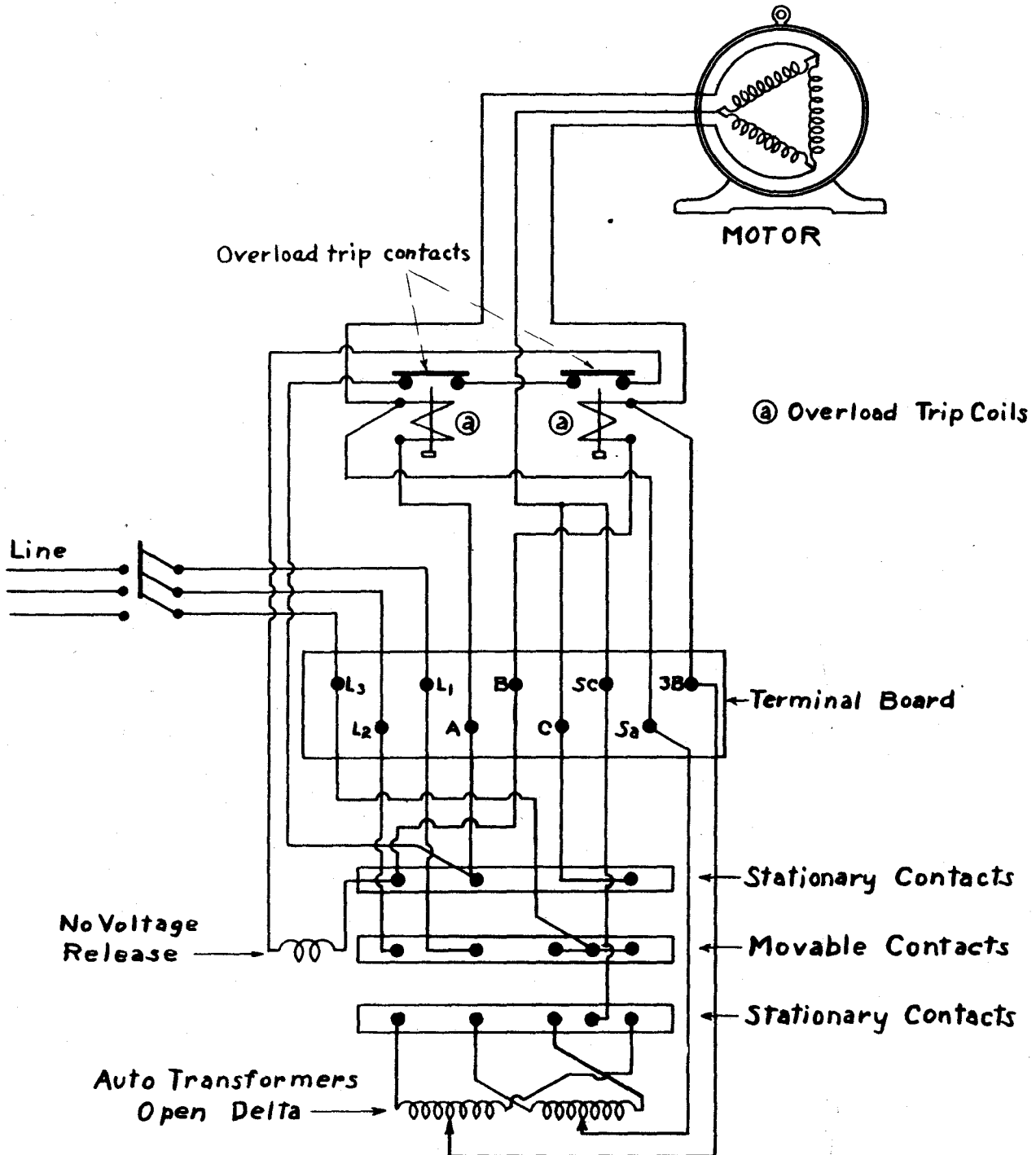

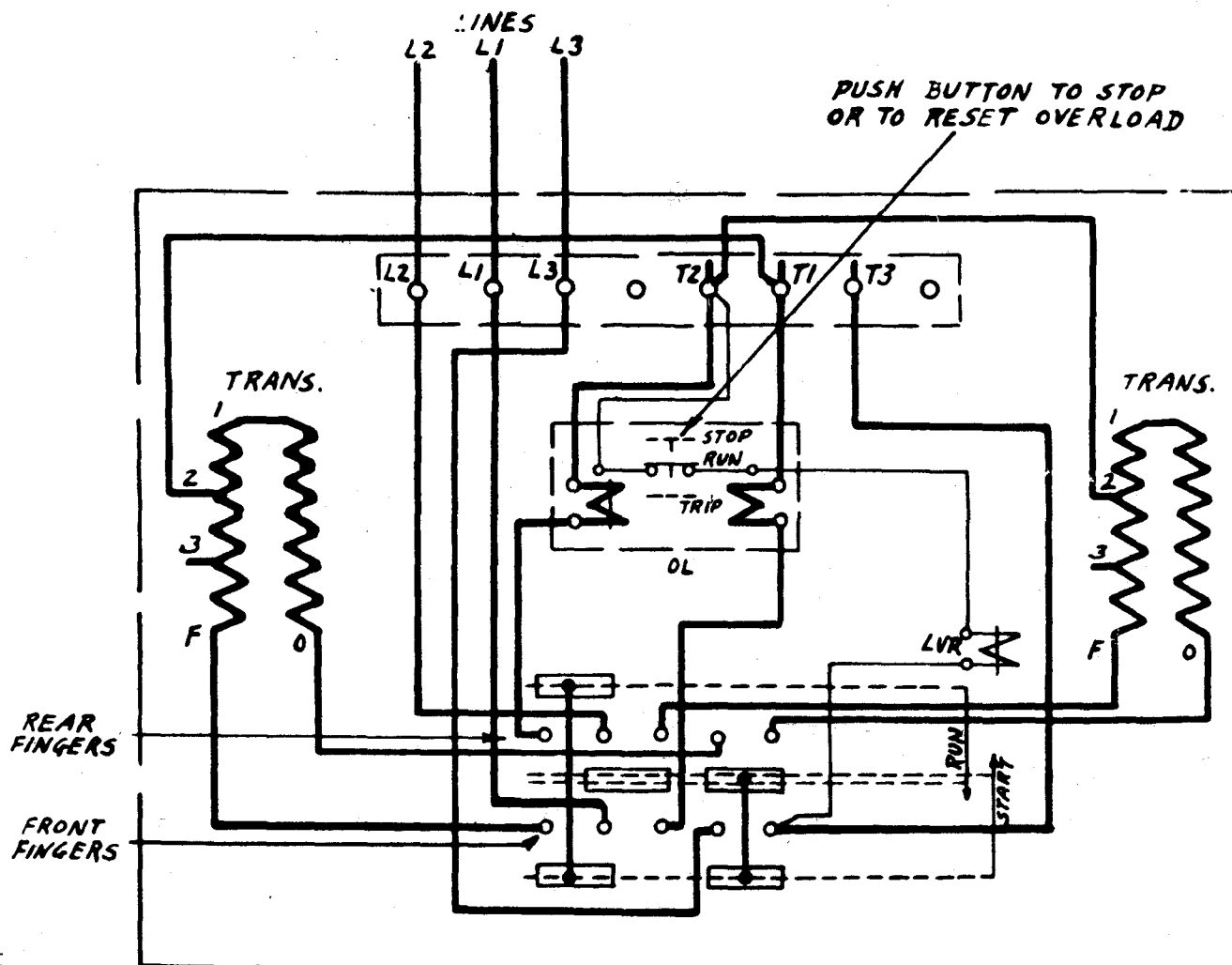

FOR 2 PHASE 3 WIRE
L3 IS COMMON LINE

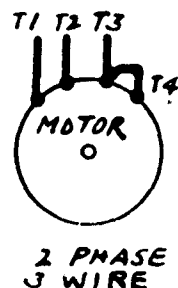
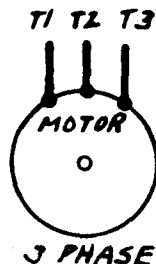

TITLE CONNECTIONS FOR AUTO-TRANSFORMER STARTER WITH OVERLOAD AND LOW VOLTAGE PROTECTION - 2 PHASE 3 WIRE OR 3 PHASE.

DRAWN BY <i>S.M. Haine</i>		REDRAWN BY <i>S.M. Haine</i>		TYPE	Sup. No.
CHECKED BY <i>TD</i>		APPROVED BY <i>A. DeK...</i>		BULL. No.	Sup. By No.
A	B	C	D	ORDER No. DEV. 1408-10	39945 DI
CUTLER-HAMMER INC. MILWAUKEE NEW YORK					



WIRING DIAGRAMS

A. C. MANUAL COMPENSATORS

CLASS 2205

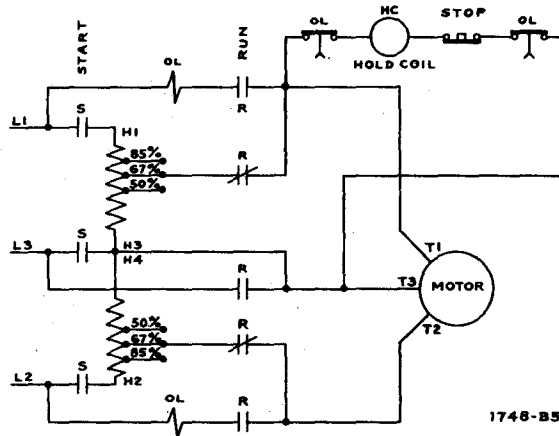
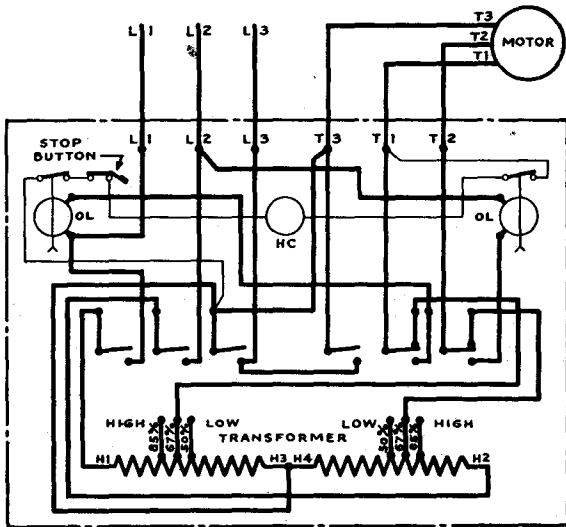

1748-B5

CLASS 2205 THREE PHASE A.C. MANUAL COMPENSATOR WITH OIL DASHPOT TYPE MAGNETIC OVERLOAD RELAYS

A. C. MANUAL SPEED REGULATORS

CLASS 2310

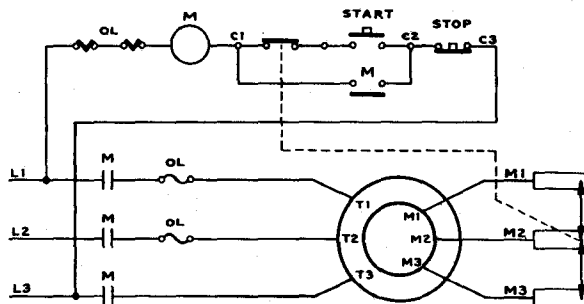
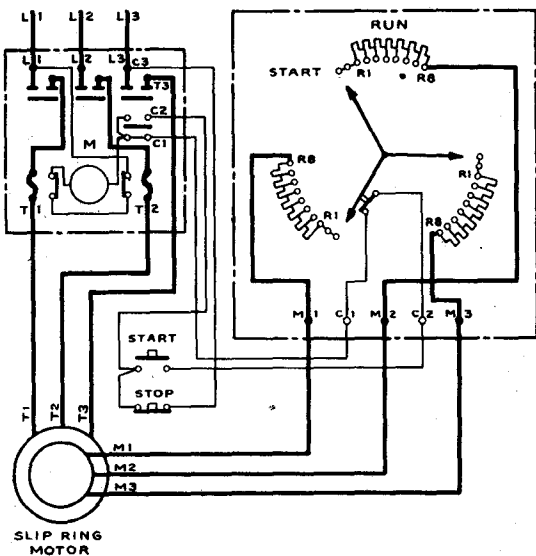

1748-B5

CLASS 2310 MANUAL SPEED REGULATOR INTERLOCKED WITH CLASS 8536 MAGNETIC STARTER FOR CONTROL OF SLIP RING MOTOR

GENERAL ELECTRIC AUTOMATIC COMPENSATOR

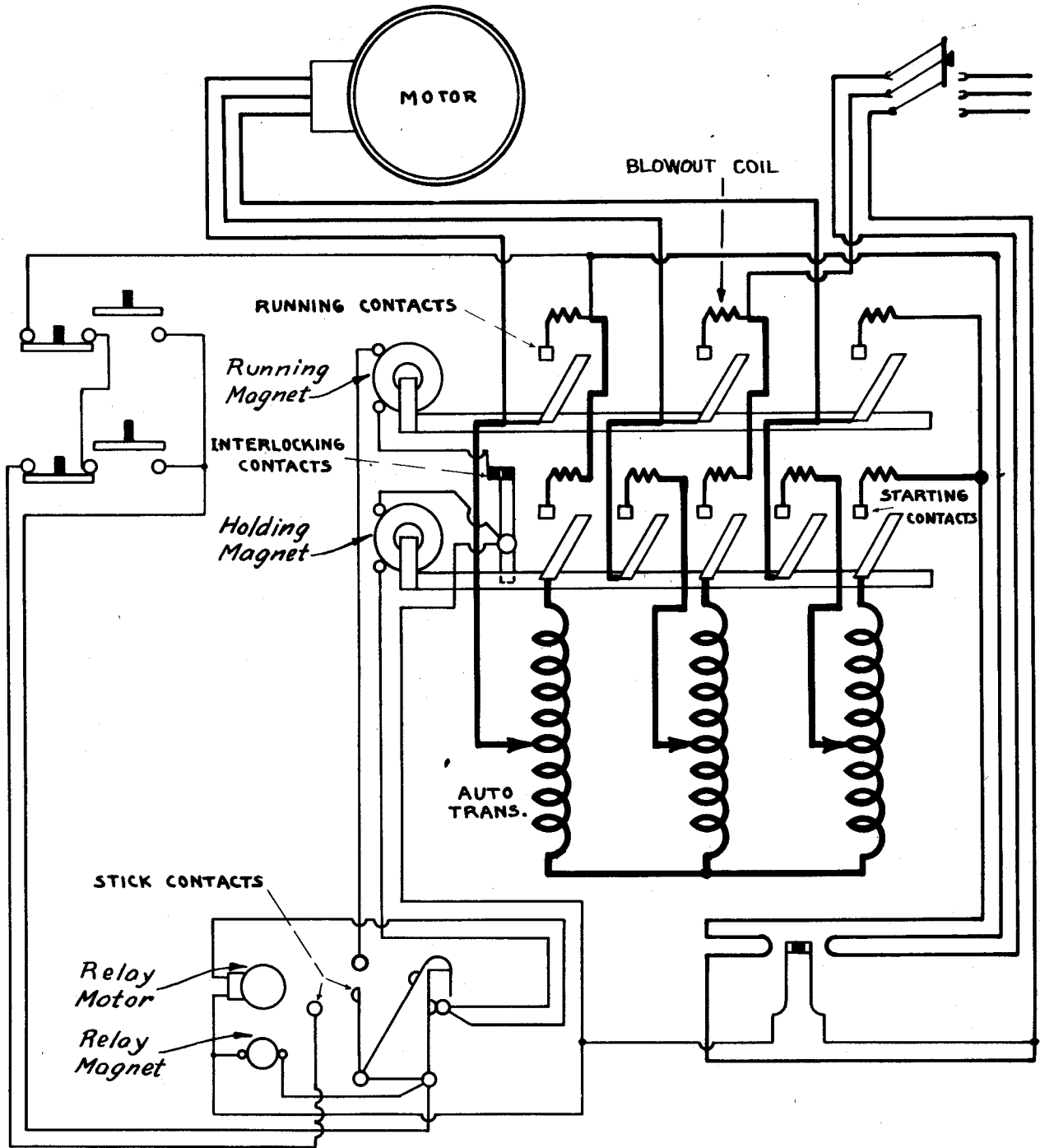

THREE POSITIONS OF TIMING RELAY
NORMAL

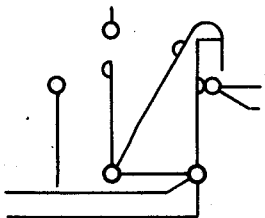

STICK OR HOLDING

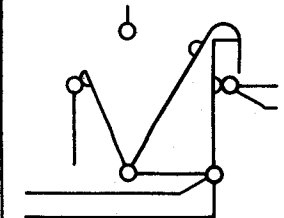

RUNNING

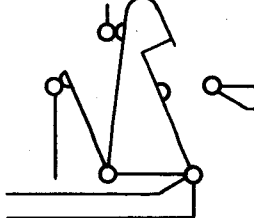

THERMOSTATIC OVERLOAD RELEASE

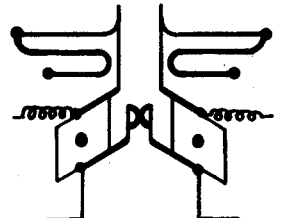

WESTINGHOUSE AUTOMATIC COMPENSATOR

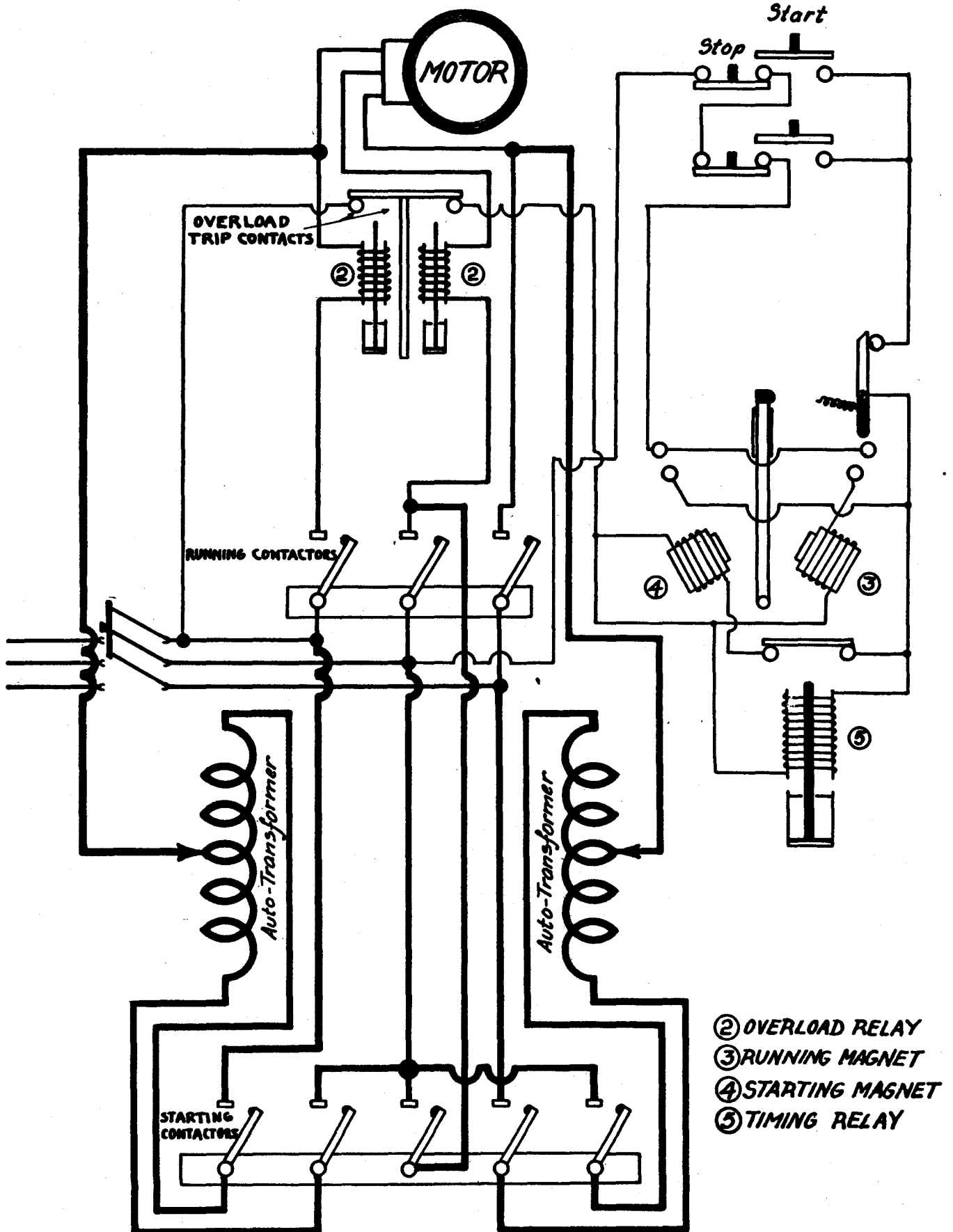

ALLEN BRADLEY AUTO TRANSFORMER STARTER -

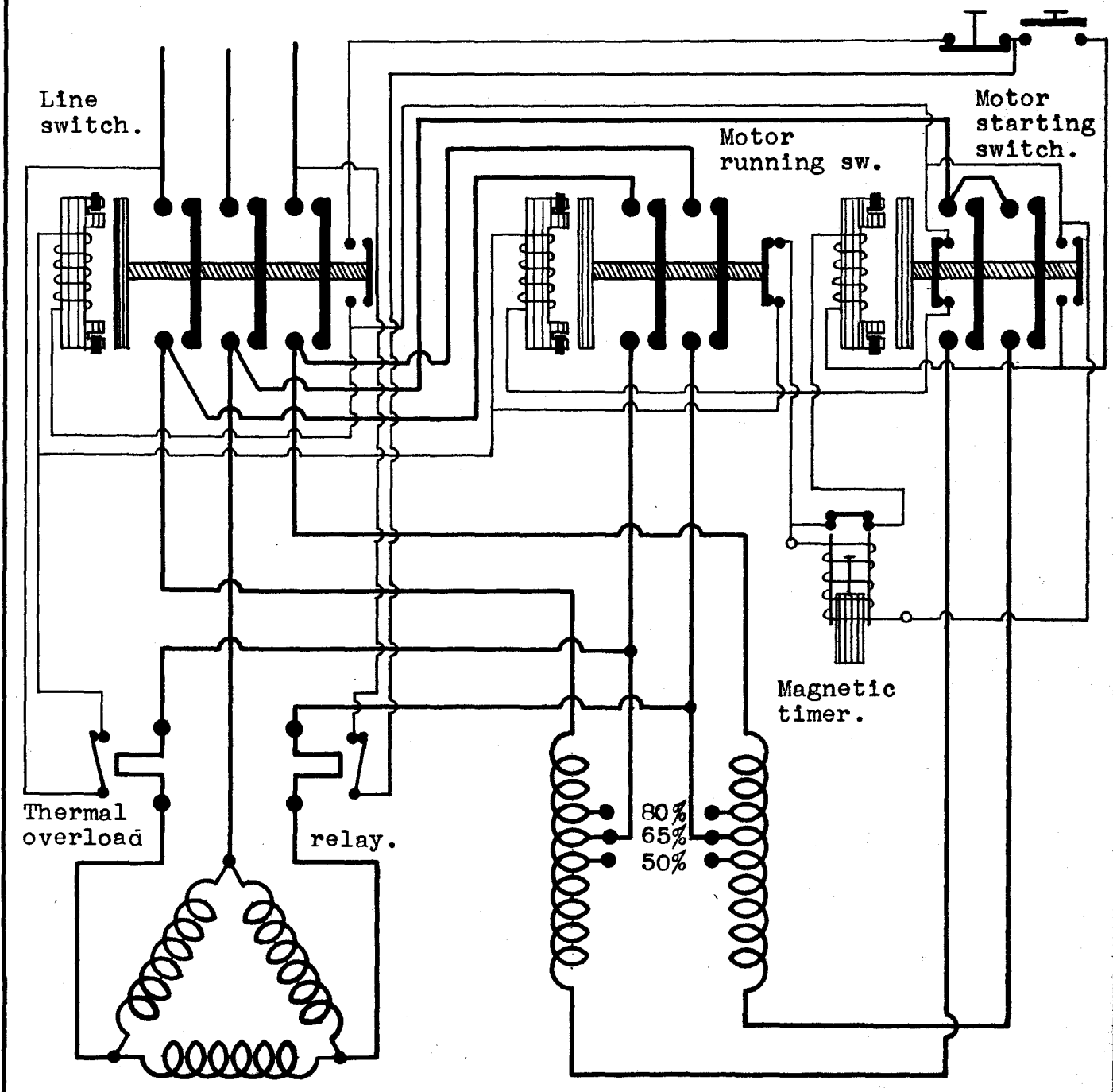

OFF POSITION

STARTING POSITION

RUNNING POSITION

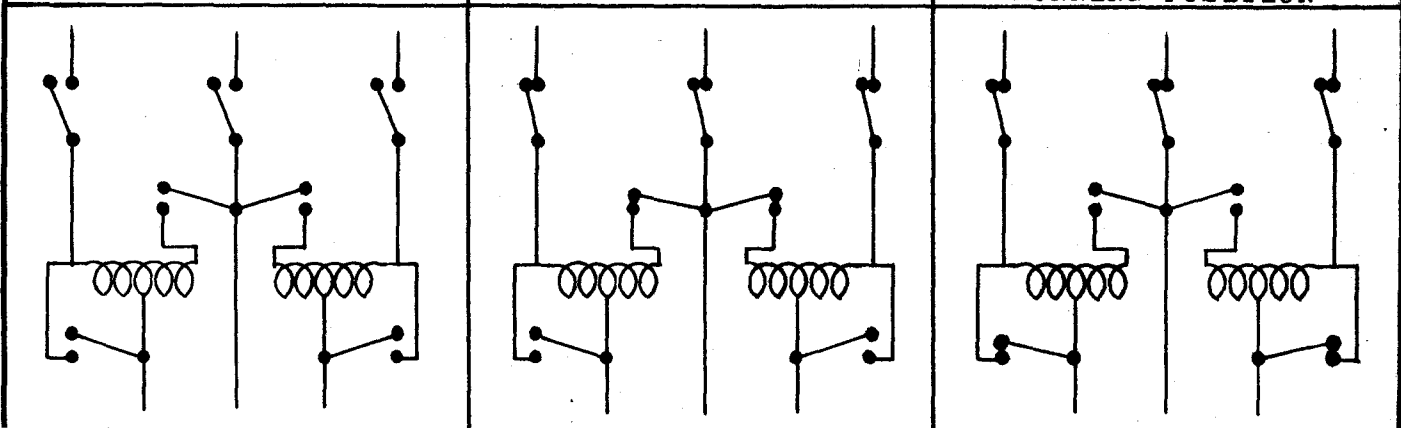

74341 D2

FRONT VIEW DIAGRAM

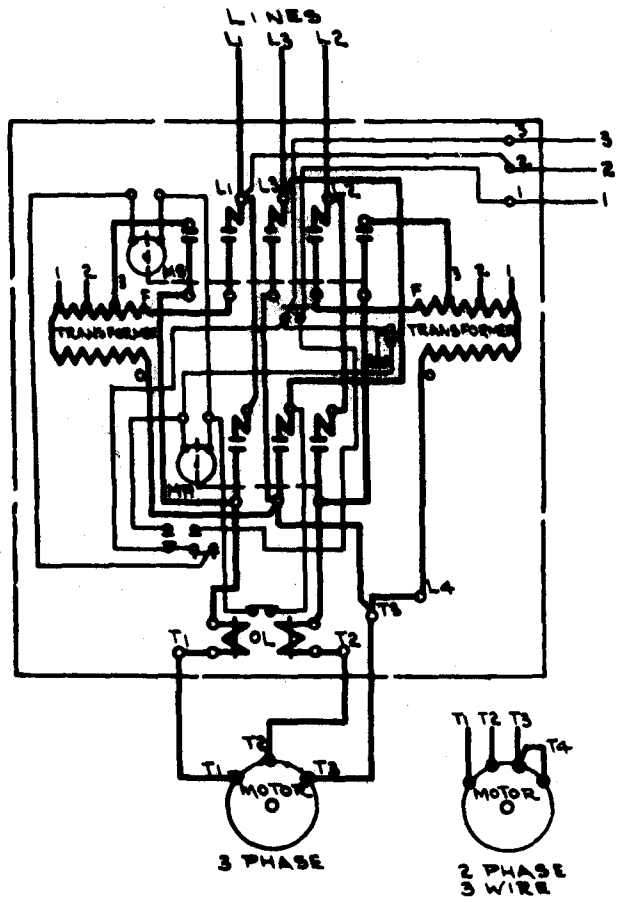

L3 IS COMMON LINE

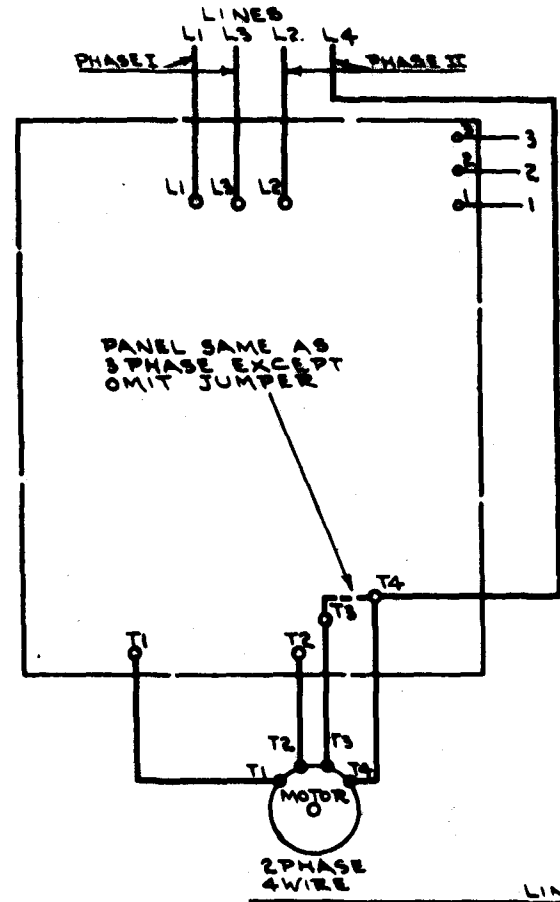

2 WIRE PILOT DEVICE

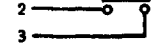

3 WIRE PILOT DEVICE

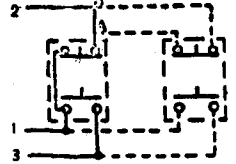

WHEN MORE THAN ONE PUSH BUTTON STATION IS USED CONNECT PER DOTTED LINES OMITTING CONNECTION "A.A."

LINE DIAGRAM=7434-0D1

CONNECTIONS FOR BULL. 9621 AUTOMATIC COMPENSATOR

A B C D E F	DRAWN BY	<i>John Hauer</i>	ORDER NO.	A851184
	TRACED BY	<i>J.B.</i>	BULL. NO.	
	CHECKED BY	<i>W. J. ...</i>	SUP. NO.	
	APPROVED BY	<i>W. J. ...</i>	SUP. BY NO.	
	CUTLER-HAMMER, INC. MILWAUKEE NEW YORK			

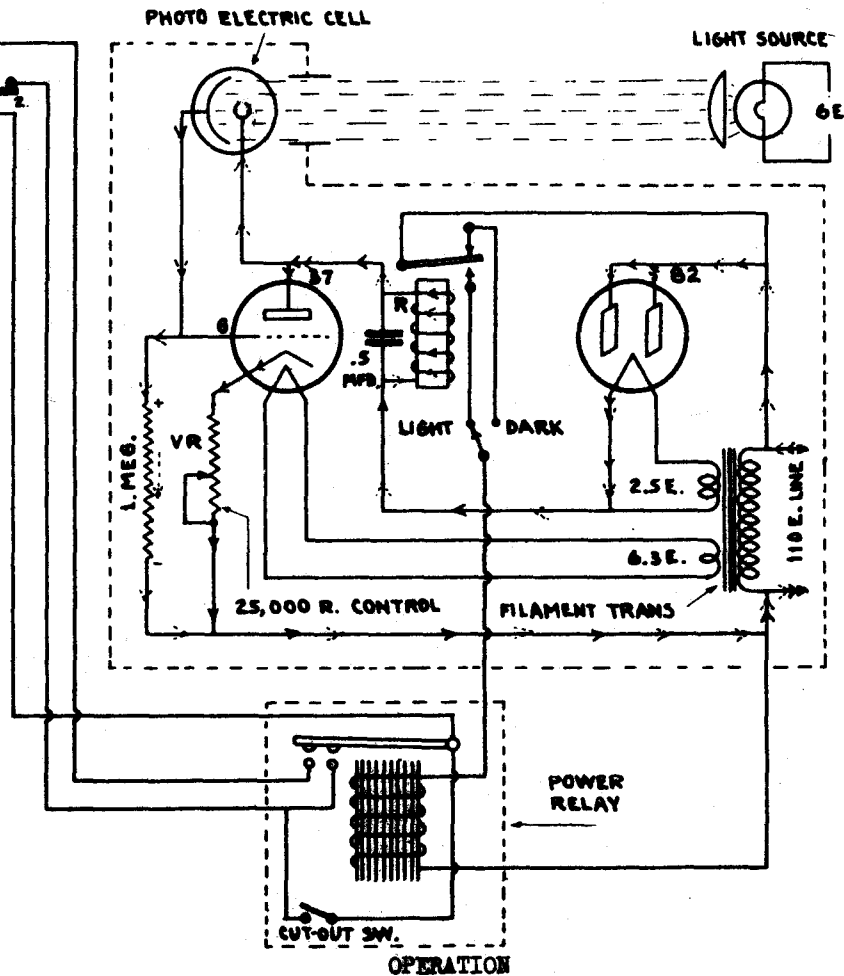
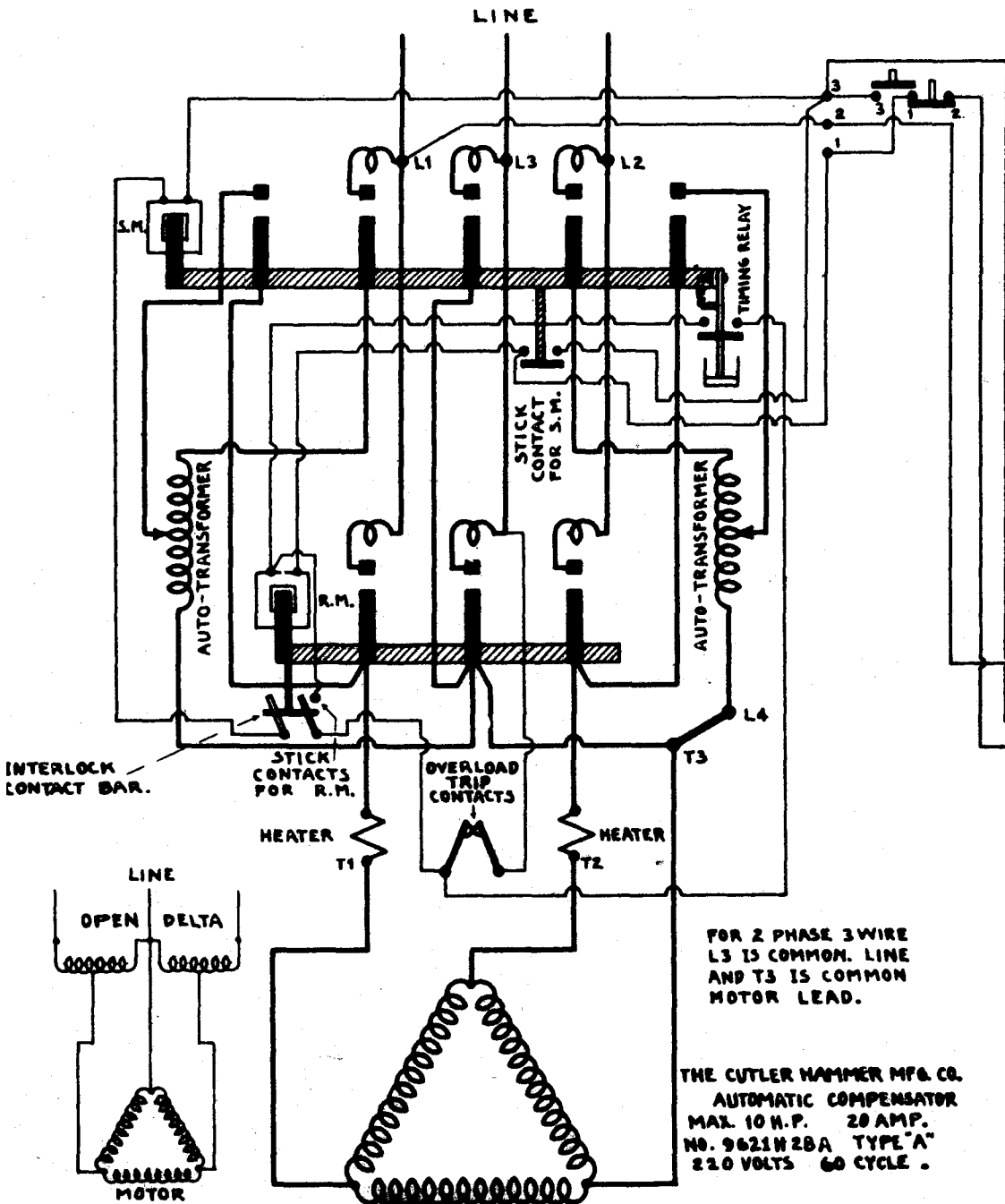

- (1) Light causes photo-cell to conduct permitting current to flow as shown by open arrows.
- (2) Voltage drop across 1 meg. resistor makes grid "G" more positive and increases plate current of the 57 tube. This circuit is traced in closed arrows.
- (3) Increased plate current operates relay "R" whose contacts energize the power relay.
- (4) Power relay contacts close and actuate the magnet on the motor starter.

Variable resistor "V.R." is used to adjust the value of the plate current so that the relay "R" will not operate when the photo-cell is dark.

STAR-DELTA STARTERS

This job is used to demonstrate the difference between the ends of each phase on a 3 phase winding, and to show that this difference must be taken into account when the phases are connected together.

Proper connection of the windings on any 3 phase motor, generator, or transformer, must be preceded by identification of the phase ends as starts and finishes, just as the proper connection of a battery to others must be preceded by the finding of the positive and negative terminals.

The simplest method of finding the starts and finishes of the phases in a three phase motor is given below. Follow each step carefully. With the windings connected star, a test will show unequal voltage per phase with an incorrect connection. This explains why the motor hums when the phases are improperly arranged.

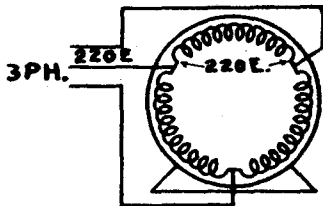

DELTA CONNECTION
SYMBOL - Δ
PH. E = LINE E

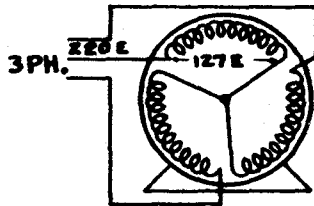

STAR CONNECTION. SYMBOL - Y
PHASE E = .58 X LINE E
LINE E = 1.73 X PHASE E

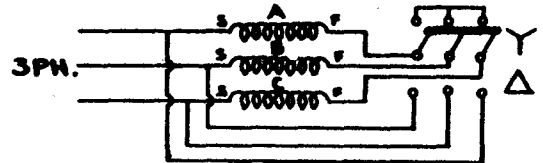

SIMPLE DIAGRAM OF A STAR-DELTA STARTER

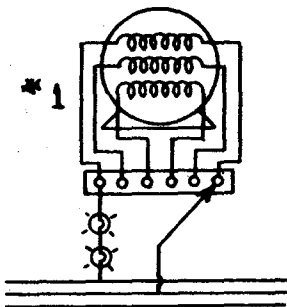

#1 TESTING TO FIND THE ENDS OF THE PHASES.

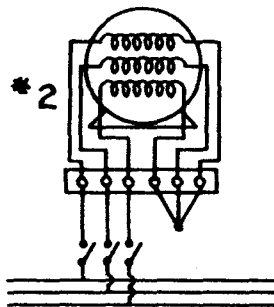

#2 ASSUME 3 ENDS TO BE FINISHES AND CONNECT TOGETHER. CONNECT 3 STARTS TO LINE.

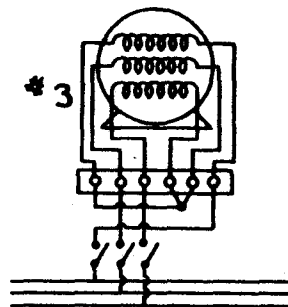

#3 IF MOTOR IS NOISY REVERSE LEADS CONNECTED TO PHASE "A" IF NO IMPROVEMENT SEE #4.

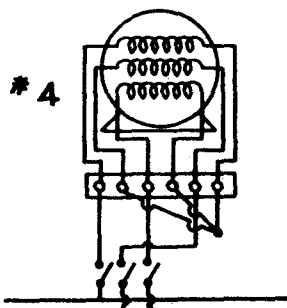

#4 REPLACE "A" LEADS AND REVERSE LEADS OF "B" PHASE. IF NO IMPROVEMENT SEE #5.

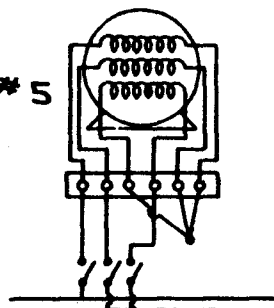

#5 REPLACE "B" LEADS AND REVERSE LEADS OF PHASE "C". MOTOR SHOULD NOW OPERATE.

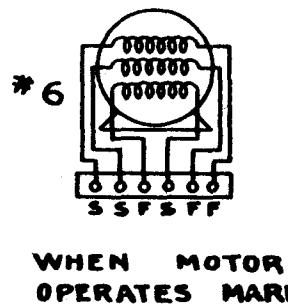

#6 WHEN MOTOR OPERATES MARK PHASES AS SHOWN ABOVE.

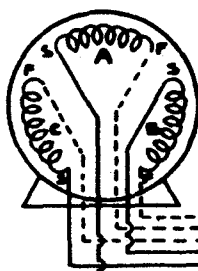

COMPLETE STAR-DELTA SWITCHING CONNECTIONS

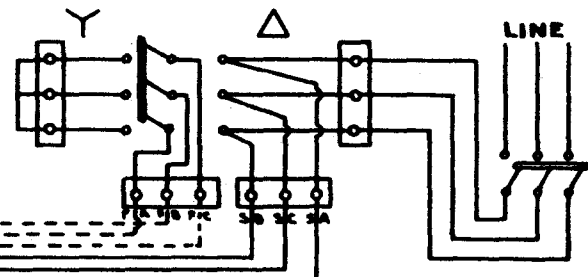

8 WAYS TO APPLY THE PLUGGING SWITCH

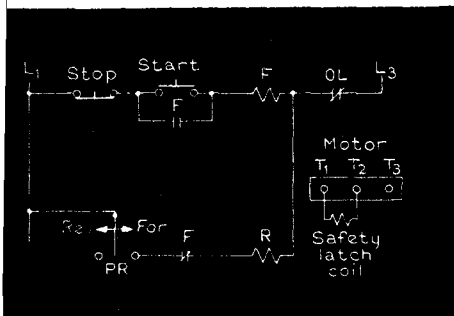

1. Operation in one direction. Pressing Stop button plugs motor to stop.

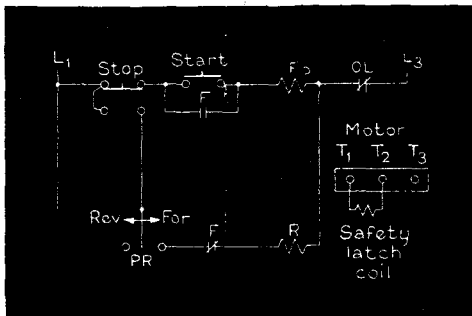

2. Operation in one direction. Pressing Stop button and immediately releasing it permits coast-stop. Holding Stop button down plugs motor to a stop.

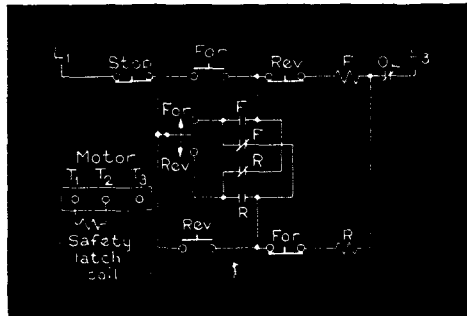

3. Operation in both directions. In starting, direction button must be held down until motor starts. Coast to stop if Stop button is held down—plug to Stop if button is released.

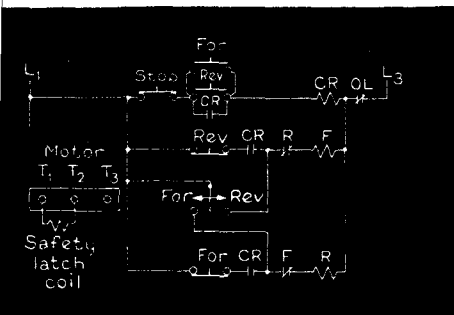

4. Same as number three except direction button need not be held down until motor starts. Pressing Stop button plugs motor to Stop from both directions.

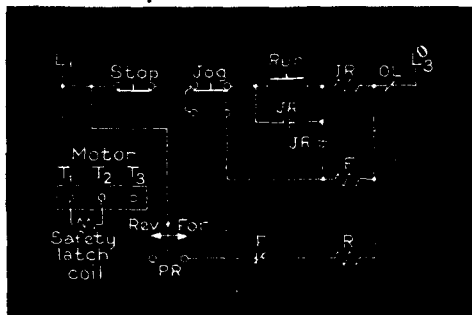

5. Operation in one direction. Plug-stop when Stop button is pressed. Jogging with auxiliary jogging relay.

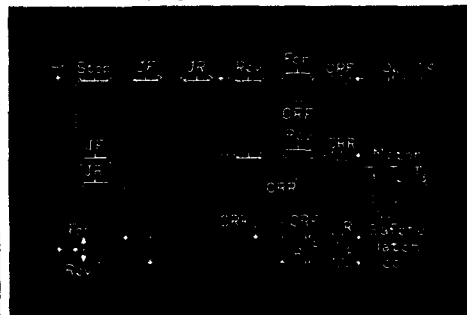

6. Operation in either direction. Jogging forward and reverse provided by auxiliary jogging relays. Plug-stop from both directions.

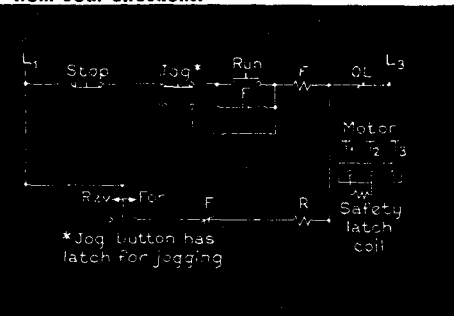

7. Operation in one direction. Jogging provided without auxiliary jogging relay by means of push-button station with latch for jogging. Plug to stop from either direction.

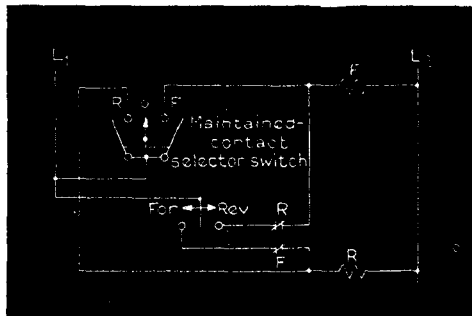

8. Operation in either direction from maintained-contact station. Plug to stop from either direction when switch is turned to Off. No undervoltage protection.

- Key to symbols in elementary diagrams
- Normal open push button
 - Normal closed push button
 - F and R Forward and reverse contacts in coils
 - For Rev Jogging switch contacts
 - Normally-closed interlock
 - Normally-open interlock
 - OL Overload relay contacts (symbols otherwise same as above)

For other circuits to fill special requirements, consult your G-E office.

Contact Arrangement Single-pole, Double-throw	Rotation to Operate Contacts (Facing Shaft)	Lockout Coil	CR2962 Form For Adjustment Range	
			40-140 Rpm	140-750 Rpm
Both throws normally open	Clockwise or counterclockwise	Yes	A1A	A1D
			No	A2A
One throw normally open, one throw normally closed	Clockwise	Yes	A1B	A1E
			No	A2B
One throw normally open, one throw normally closed	Counterclockwise	Yes	A1C	A1F
			No	A2C

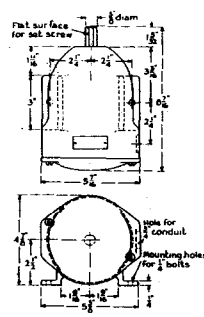
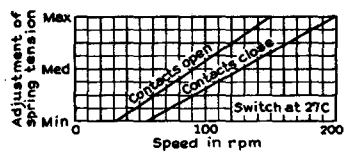
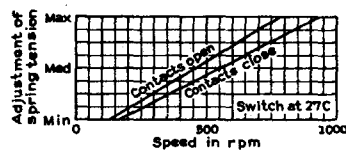

GENERAL ELECTRIC

SCHENECTADY, N.Y.



STANDARD LINE DIAGRAM SYMBOLS

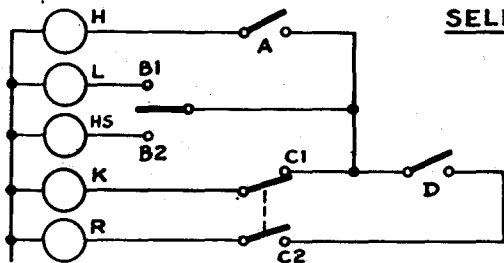

SELECTOR SWITCH AND ACCOMPANYING TARGET TABLE

DOUBLE CIRCUIT UNITS

FUNCTION	A	B1	B2	C1	C2	D
OFF				X		
HIGH	X		X	X		X
LOW		X			X	X
TORQUE					X	X

X - INDICATES CONTACTS CLOSED

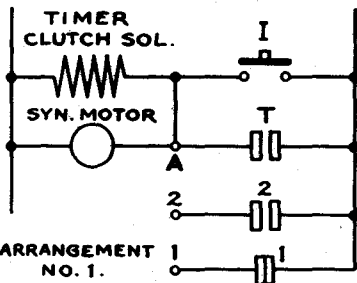

MICROFLEX TIMER

WITH EACH TIMER INDICATE EAGLE SIGNAL ARRANGEMENT NUMBER AND SHOW THE TARGET TABLE FOR THAT ARRANGEMENT:

SEQUENCE	CONTACT			
	I	T	1	2
POWER OFF			X	
P. B. CLOSED	X	X		X
TIMING		X		X
TIMED OUT			X	

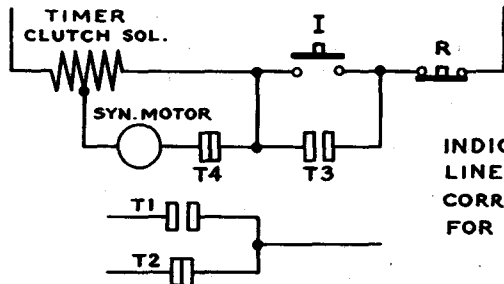

G.E. TIMER (CR 2820-1099)

INDICATE ON OR WITH LINE DIAGRAM THE CORRECT TARGET TABLE; FOR EXAMPLE :

SEQUENCE	CONTACT					
	T1	T2	T3	T4	I	R
POWER OFF		X		X		X
P. B. CLOSED		X	X	X	X	X
TIMING		X	X	X		X
TIMED OUT	X		X			X
RESET		X		X		

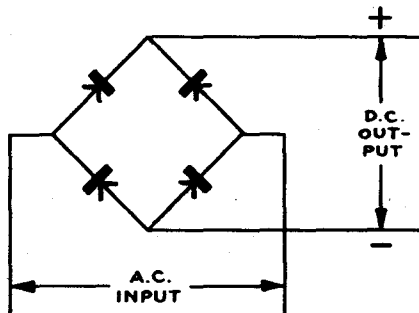

FULL WAVE RECTIFIER

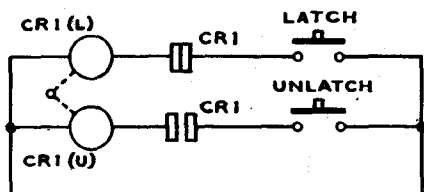

MECHANICALLY HELD CONTACTORS

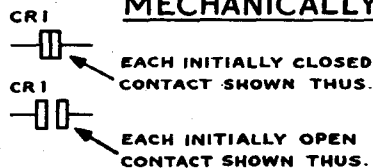

EACH INITIALLY CLOSED CONTACT SHOWN THUS.

EACH INITIALLY OPEN CONTACT SHOWN THUS.

THIS RELAY IS SHOWN IN THE POSITION OBTAINED BY ENERGIZING COIL CR1(U) LAST.

1748-C8.

TYPE TSA-14 TIME SWITCHES

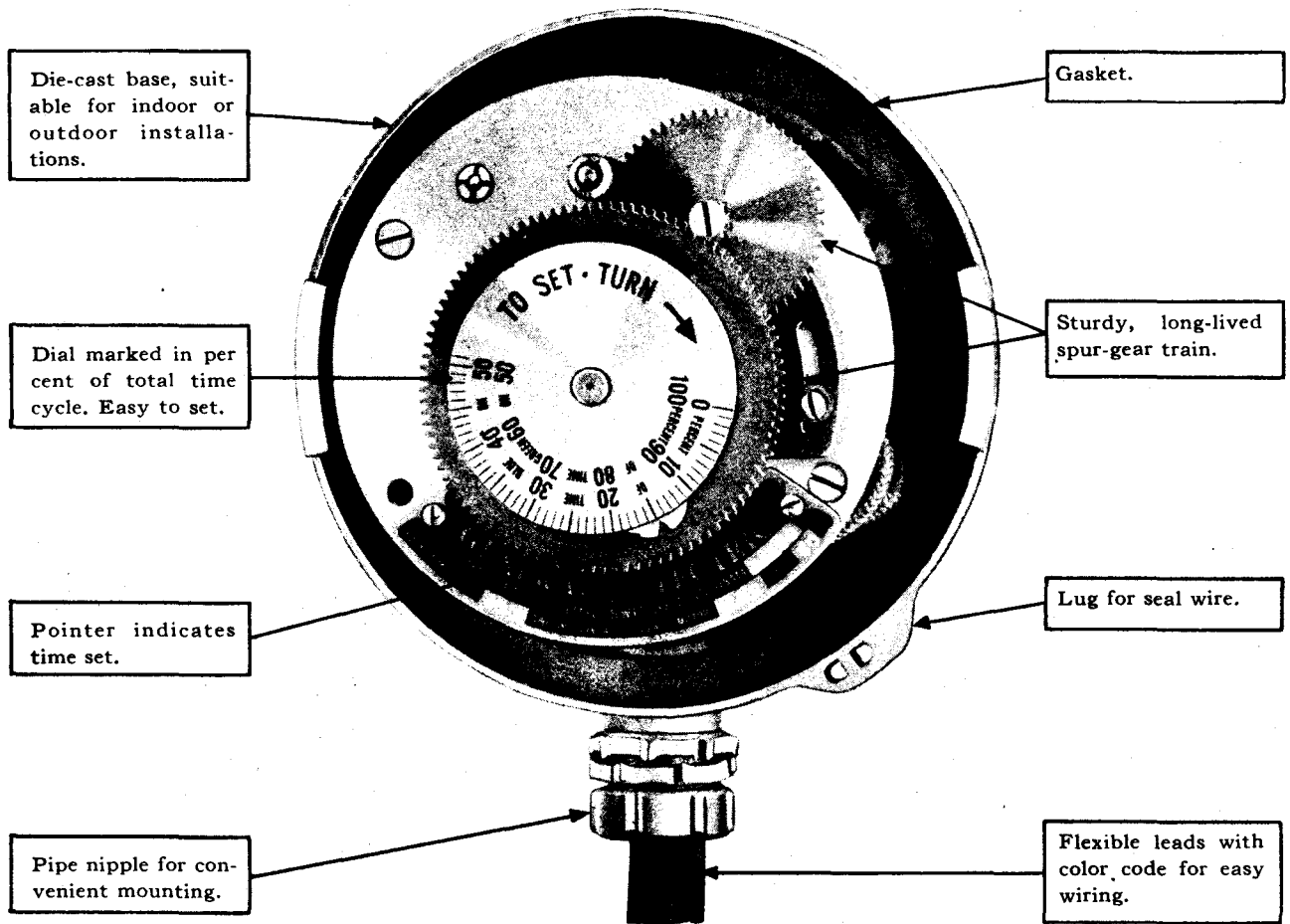

Fig. 1

DESCRIPTION

The timer consists of a contact-making mechanism driven by a spur-gear train from a Telechron motor, together with a means of adjusting contact-closed time as a percentage of the repeating-cycle time.

The contact-making mechanism consists of brushes which bear on rotating cams. Silver contacts are mounted on the brushes, and the contacts are snapped "Open" and "Closed" by means of steps on the rotating cams.

The timer is housed in a die-cast base and a glass cover. This housing is suitable for either indoor or outdoor installation. The pipe nipple in the die-cast base furnishes an easy means of mounting the timer in a knockout of any convenient junction box or switch box. Flexible leads of ample length are provided for easily connecting the contacts to the circuit to be controlled.

The cover can be sealed by a standard seal wire through lugs on the base and glass cover.

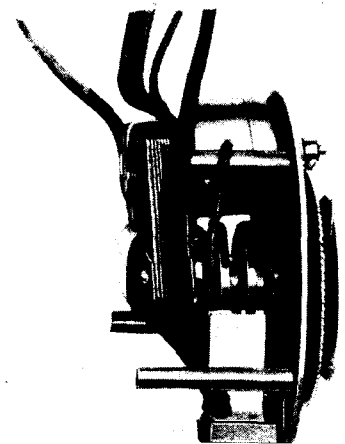
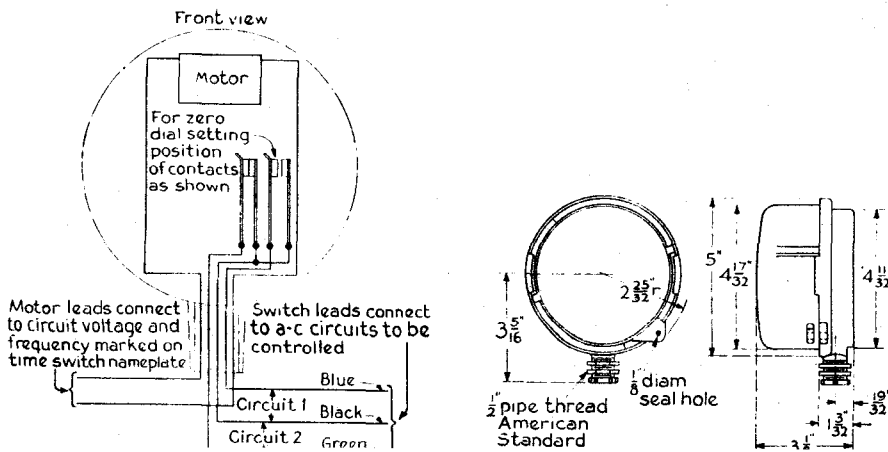

SIMPLIFIED GUIDE

TO THE SELECTION AND APPLICATION OF COMMONLY USED MOTOR CONTROLS

ONE might say that motors and their controls go together like "ham and eggs." One cannot be considered without the other.

A motor is limited in what it can accomplish. It furnishes torque at the shaft and can run in both directions.

The control is that part of the drive that makes the motor do what is desired. But the starting, stopping, and reversing of an electric motor are only a few of the contributions that motor control makes to the efficient operation of the modern electric drive.

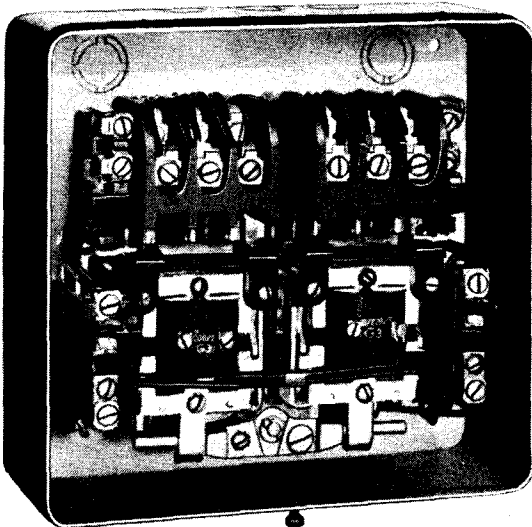

A-c magnetic reversing starter with front cover removed

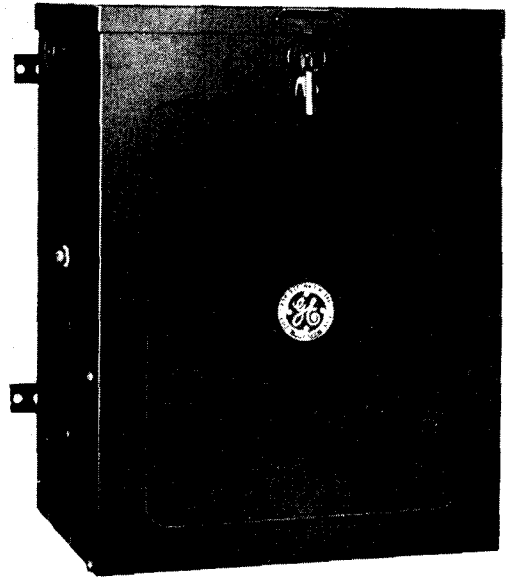

Autotransformer-type CR7051, reduced-voltage magnetic compensator with built-in undervoltage protection and overload protection

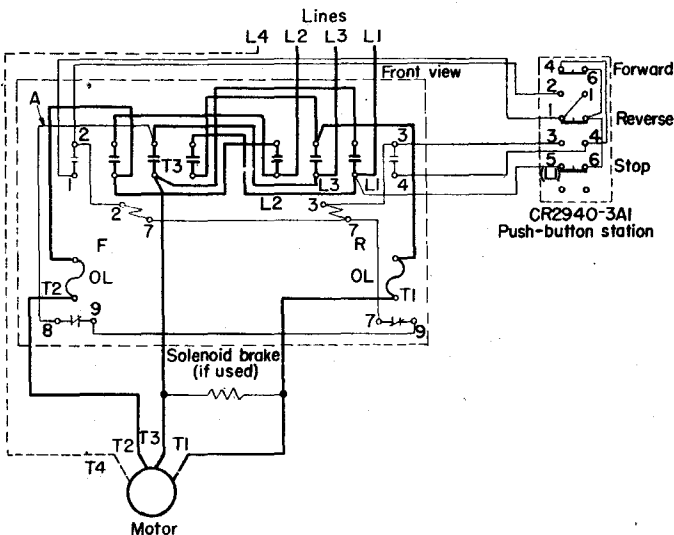

Wiring diagram of CR7009 reversing starter

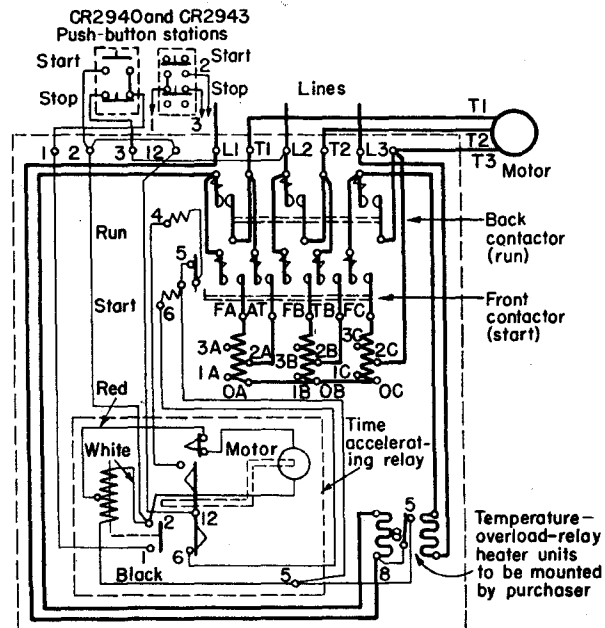

If S P master switch is used, connect as shown

Coil	Tap No.	Per cent line volts obtained
	1	2 taps
		65
	2	80

Diagram for connection of CR7051 compensator with a three-phase, squirrel-cage induction motor

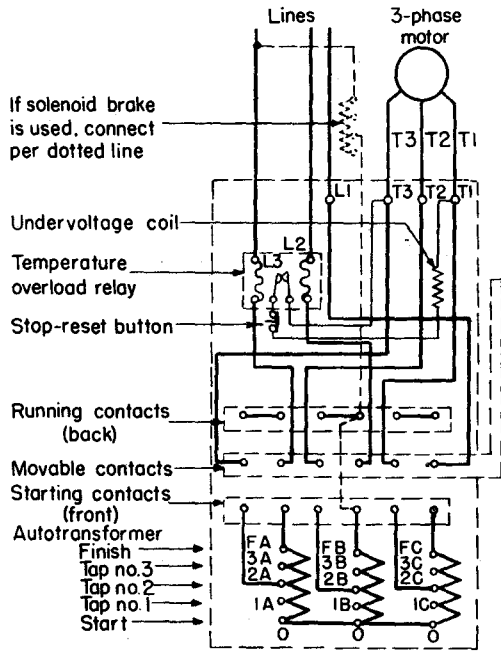

Wiring diagram of CR1034 compensator

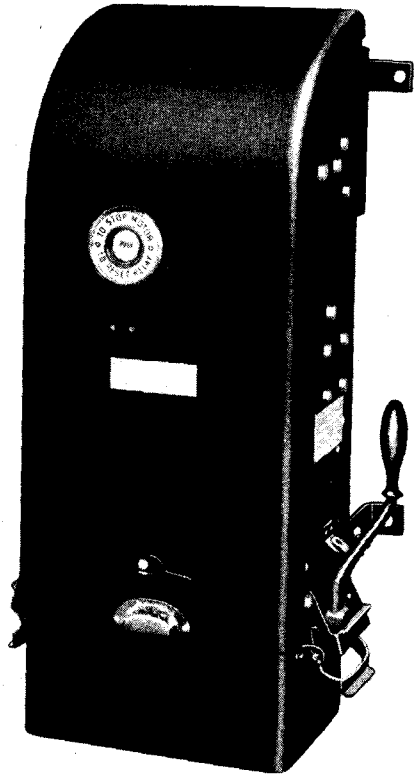

CR1034, size 1 compensator

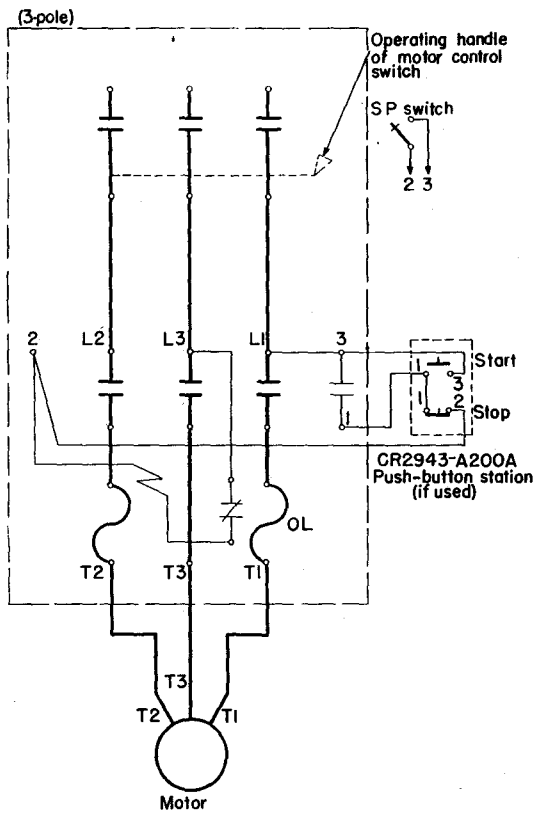

Wiring diagram for CR7008 combination starter

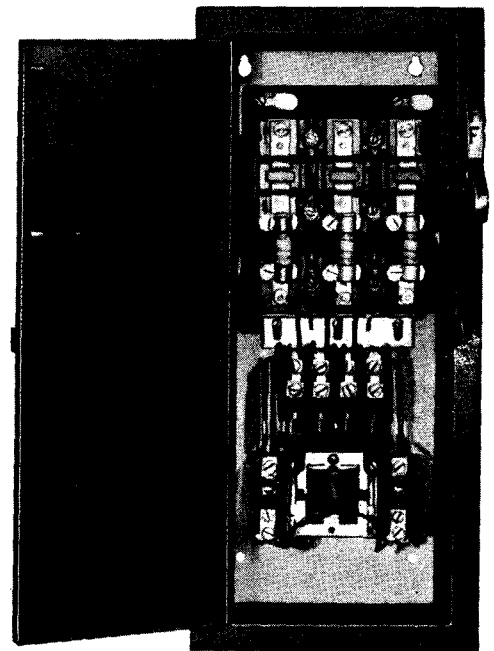

G-E CR7008 combination a-c magnetic starter with cover open

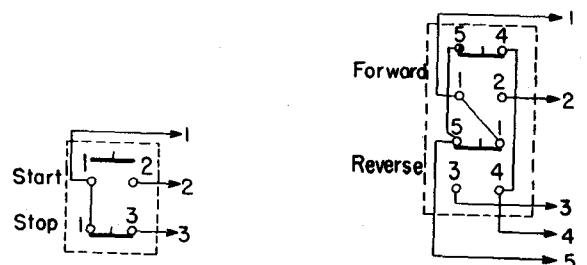

2 - SPEED CONSEQUENT POLE SQUIRREL CAGE MOTOR AND STARTER

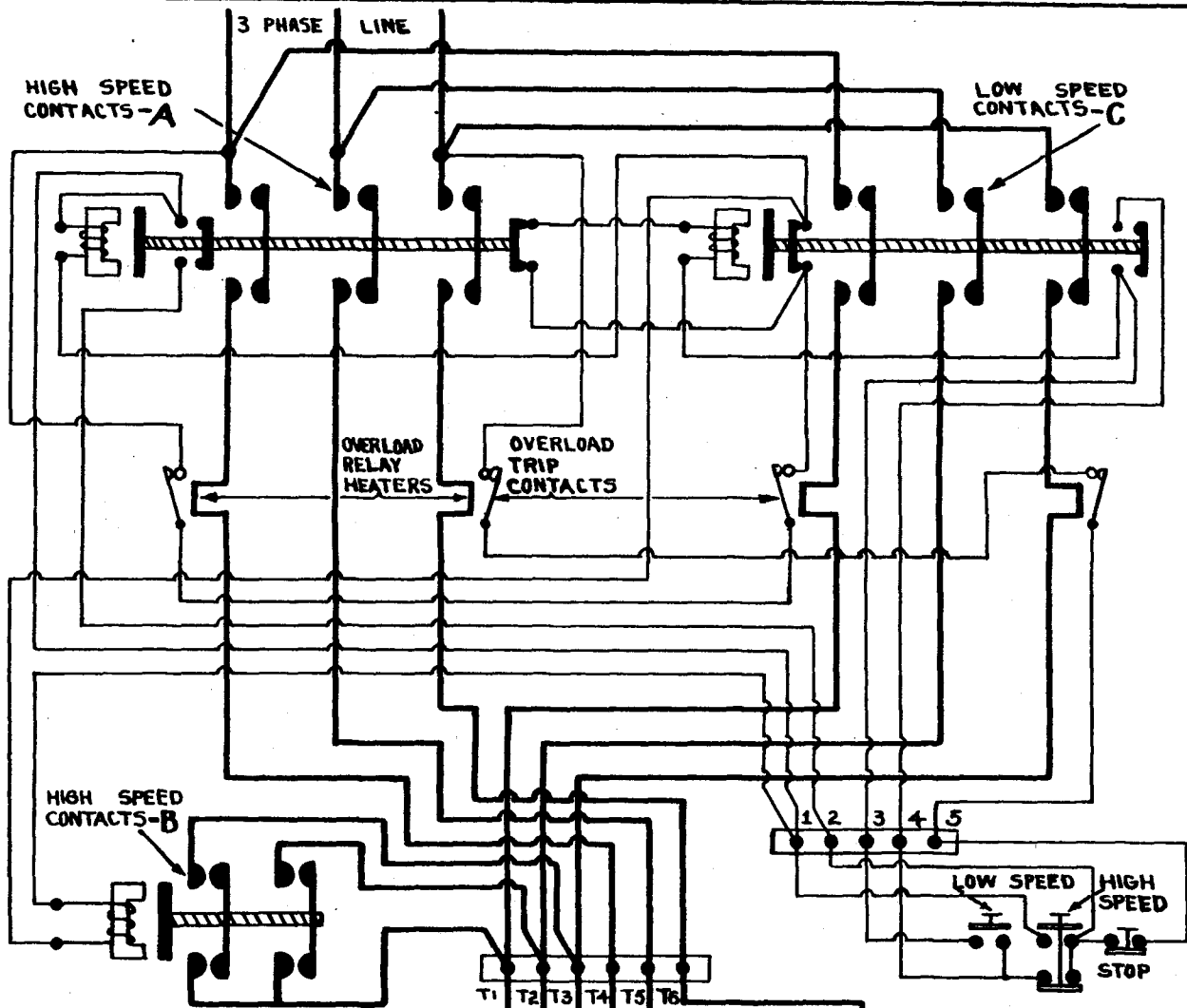

HIGH SPEED CONSEQUENT POLE CONNECTION.
CONNECT TO LINE T4-T5-T6
CONNECT TOGETHER-T1-T2-T3
CONSEQUENT POLE CONNECTION CAUSES 8 POLE WINDING TO OPERATE AS 4 POLE PARALLEL STAR.

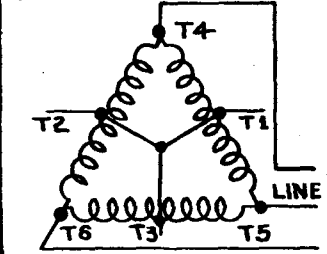

LOW SPEED SERIES DELTA 8 POLE STATOR WINDING.
CONNECT TO LINE T1-T2-T3
OPEN T4-T5-T6

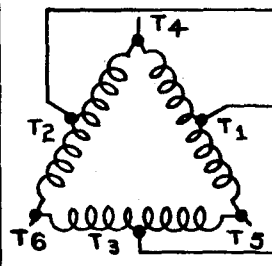

With a given frequency, the speed of an induction motor can be changed only by altering the number of poles. This may be accomplished by: (a) using two distinct windings in the stator; (b) employing a special winding in which the number of poles can be varied by reconnecting the winding external to the motor. The winding in the motor shown above uses the latter method, one connection producing four poles and the other eight and giving speeds of about 1800 and 900 R.P.M. respectively. The required change in connections is easily and quickly made by the special type controller shown above. This starter has three sets of contactors that are so mechanically and electrically interlocked that pressing of the low speed button will close contactor C only, whereas pushing the high speed button will result in A and B being pulled in, and this action will cause C to drop out. A check on the wiring will show that it is impossible for both the high speed and the low speed contactors to be in at the same time. Inspect this equipment, note the action of the relays, and trace the circuits.



ENGINEERING INFORMATION
CONNECTION DIAGRAMS MULTI-SPEED CAPACITOR MOTORS
TYPE CPXM 3 SPEED 3 WINDING

1 PHASE

TWO RELAY CONTROL SHOWING LOW SPEED & MEDIUM SPEED ON RELAY #1; HIGH SPEED ON RELAY #2

NOTE: Three pole switch must be used for satisfactory operation of relay if used for starting and stopping the motor. If speed changing switch is used for starting and stopping a 2 pole S.T. disconnect switch may be used.

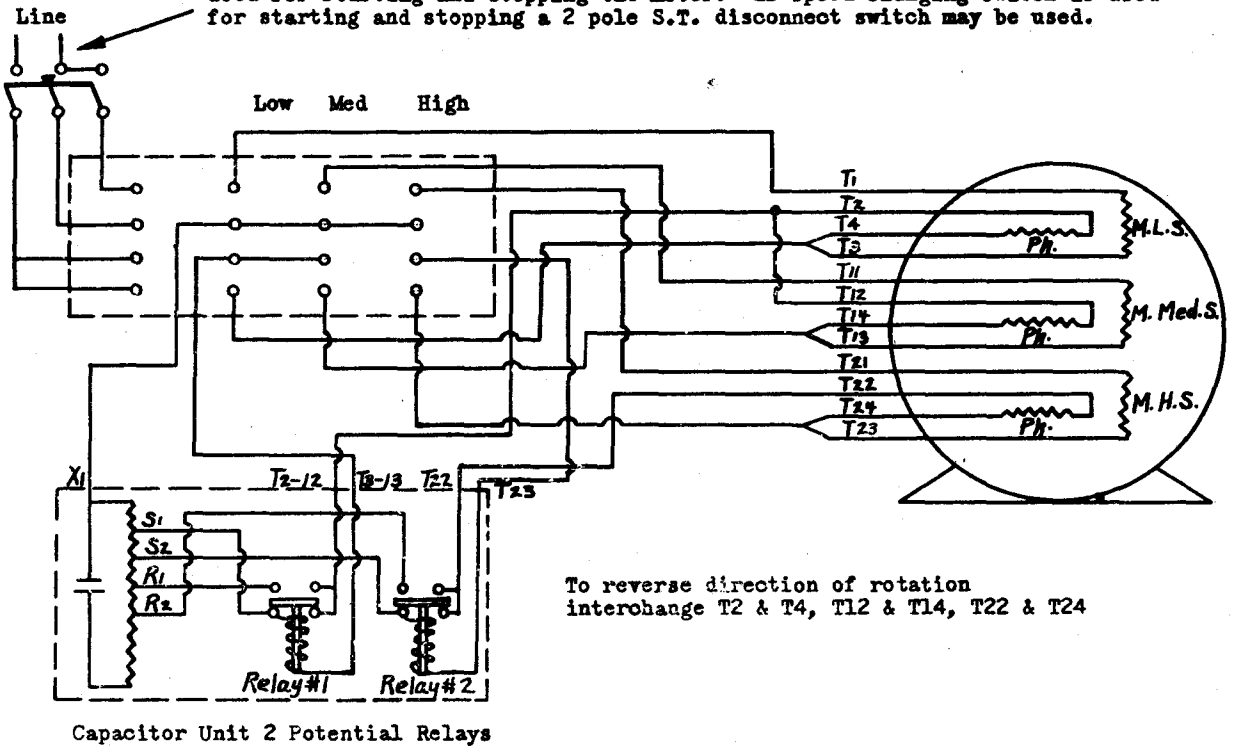

TWO RELAY CONTROL SHOWING LOW SPEED ON RELAY #1; MEDIUM SPEED & HIGH SPEED ON RELAY #2

NOTE: Three pole switch must be used for satisfactory operation of relay if used for starting and stopping the motor. If speed changing switch is used for starting and stopping a 2 pole S.T. disconnect switch may be used.

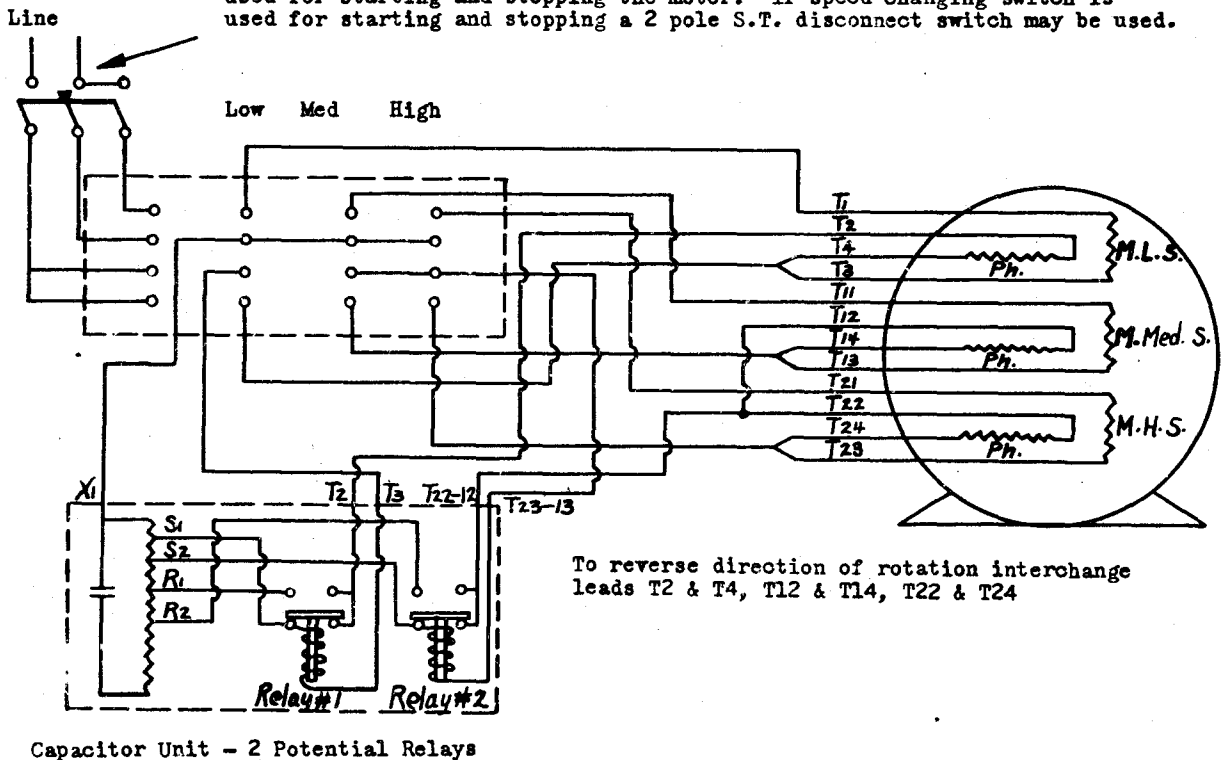

WIRING DIAGRAMS



CLASS 2510

A. C. MANUAL LINE VOLTAGE STARTERS

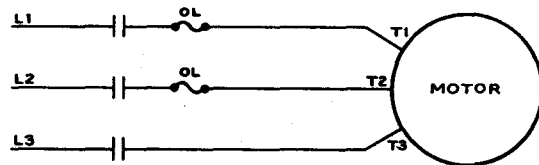
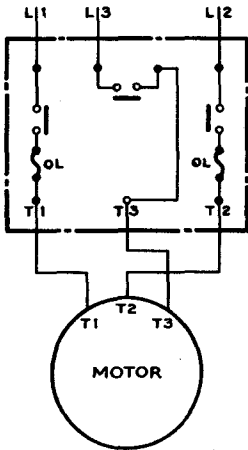

CLASS 2510, TYPE W10

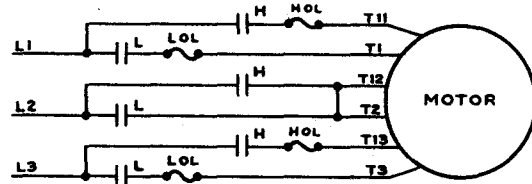
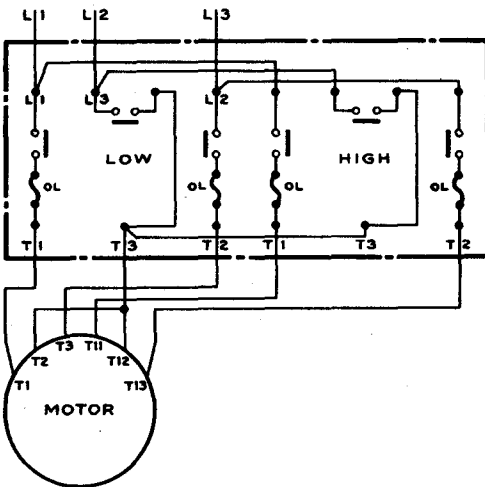

CLASS 2510, TYPE W20
FOR TWO-SPEED SEPARATE WINDING
"Y" CONNECTED MOTORS.

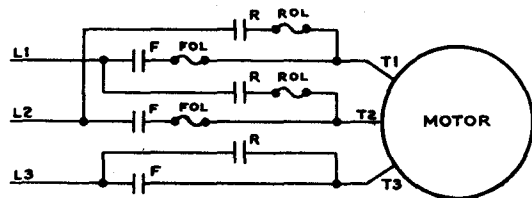
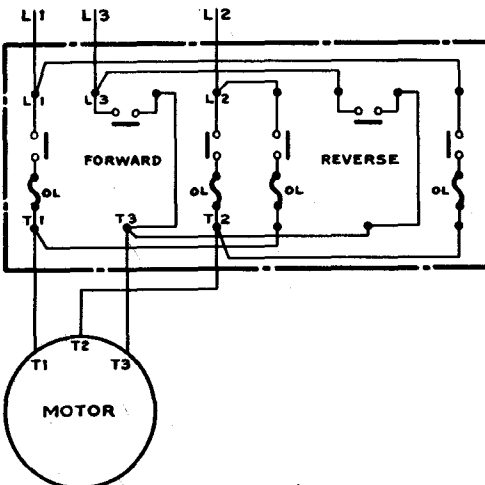

CLASS 2510, TYPE W21
REVERSING STARTER

1748-B4



WIRING DIAGRAMS

A. C. REVERSING MAGNETIC STARTERS

CLASS 8736

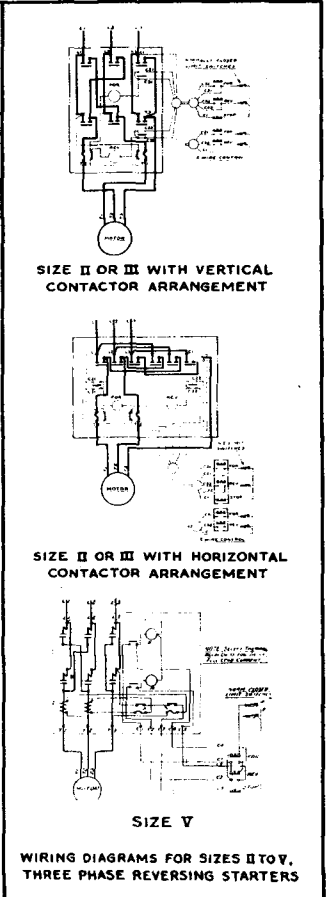
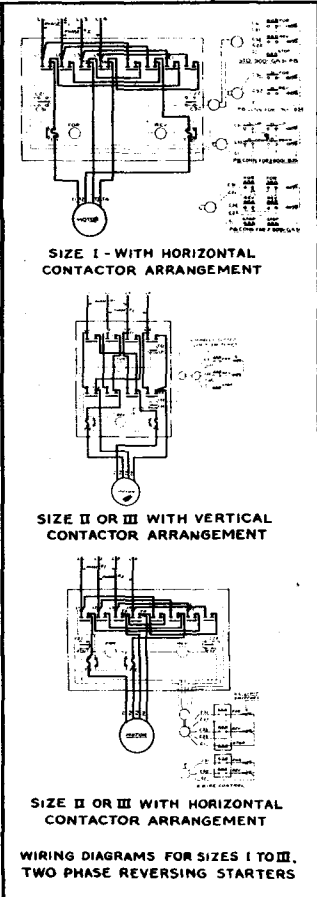
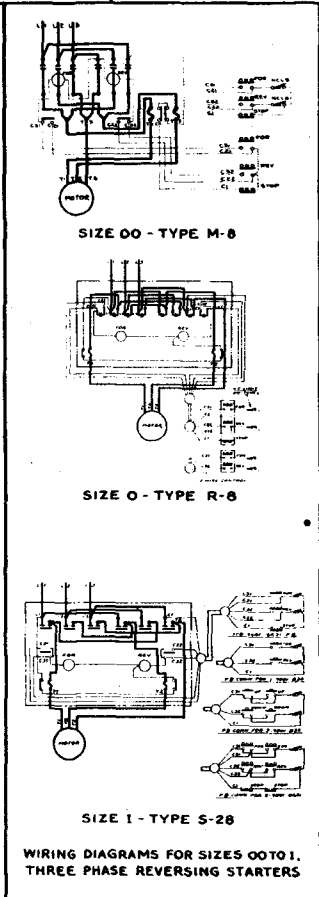
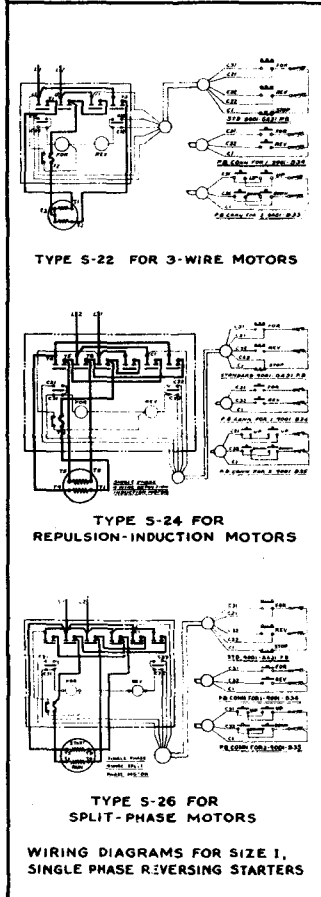
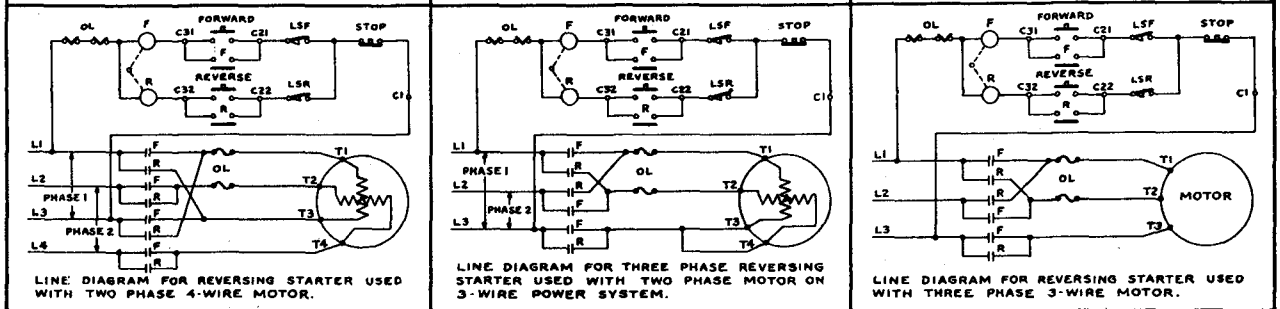
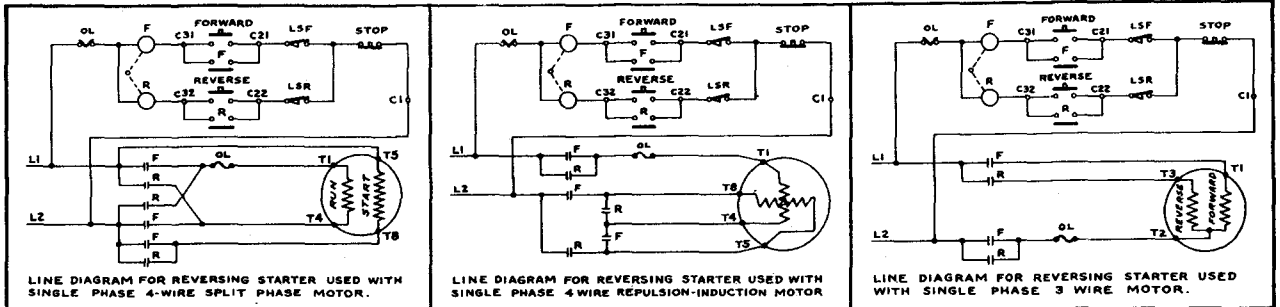

DRUM CONTROLLER - SLIP RING INDUCTION MOTOR

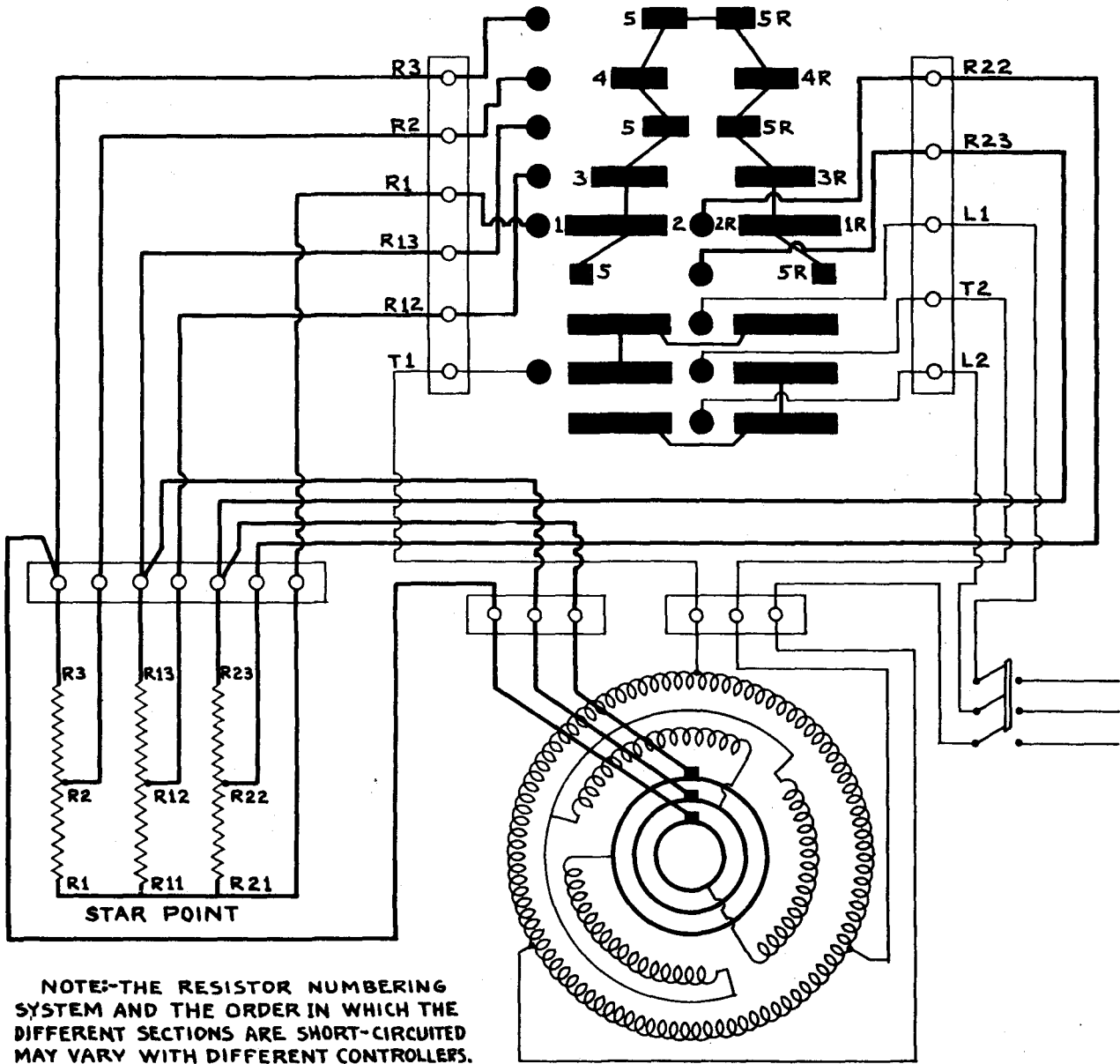

NOTE-THE RESISTOR NUMBERING SYSTEM AND THE ORDER IN WHICH THE DIFFERENT SECTIONS ARE SHORT-CIRCUITED MAY VARY WITH DIFFERENT CONTROLLERFS.

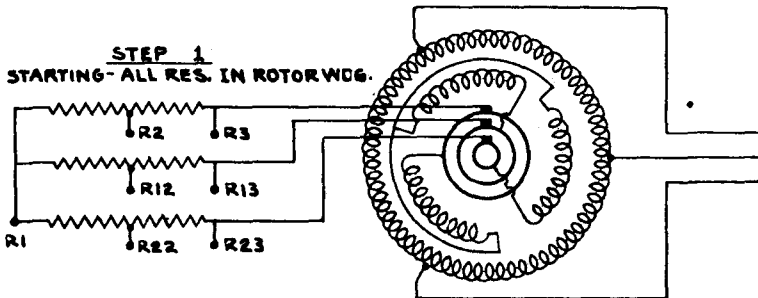

TRACE CIRCUIT THROUGH EACH STEP SHOWN.

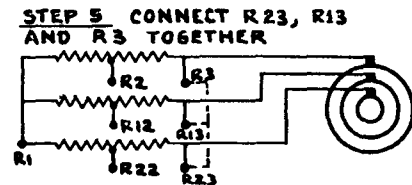
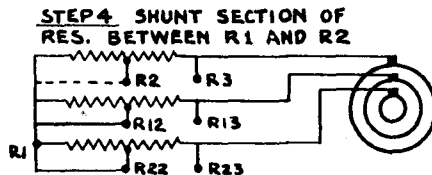
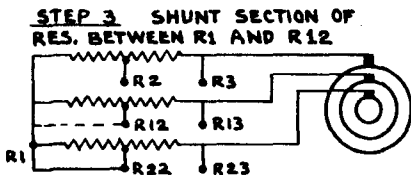
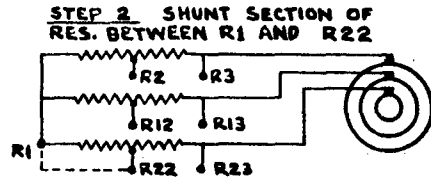

DRUM CONTROLLER (5 SPEED).

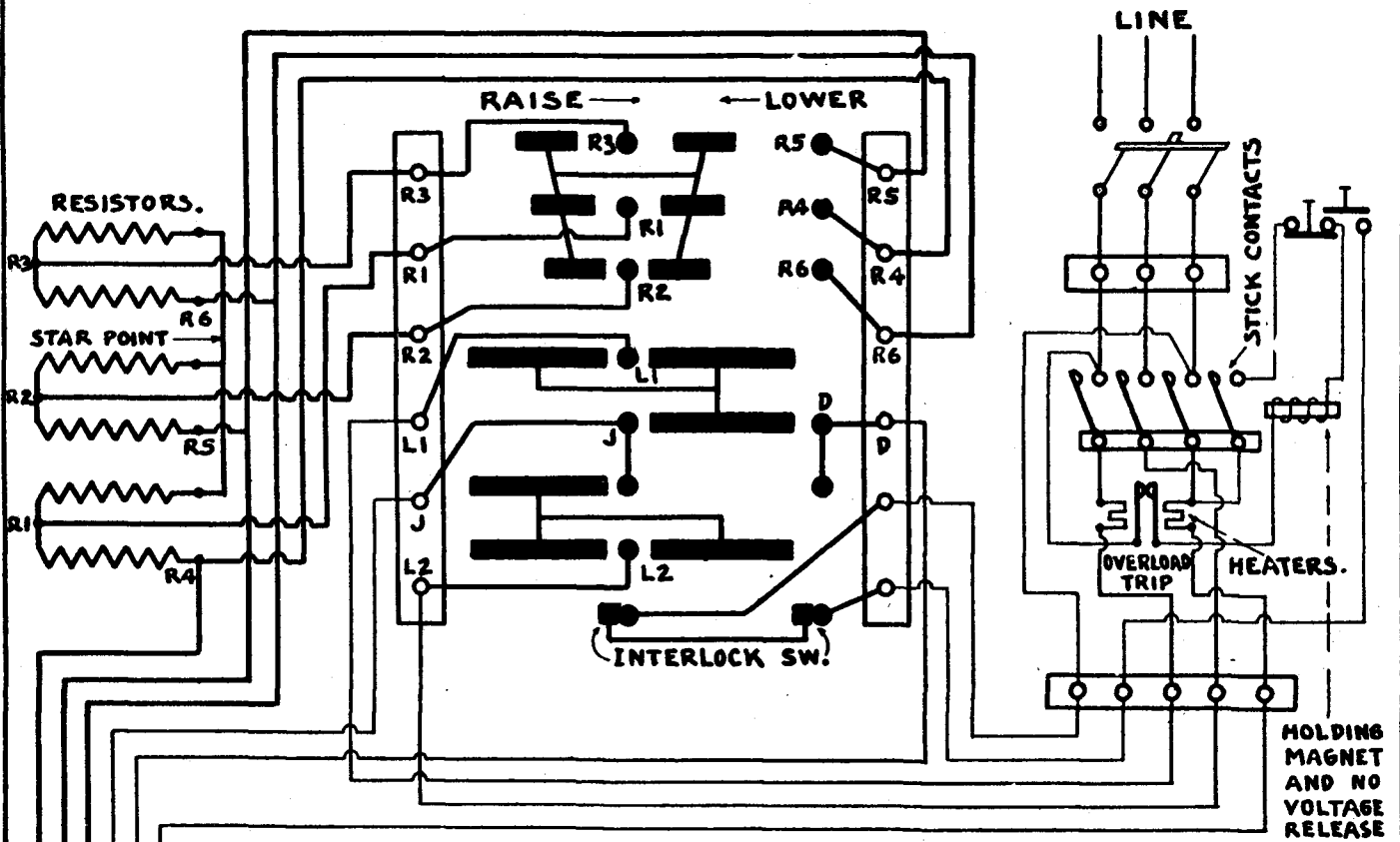

L1	} LINE LEADS	1-7-6	} FOR 220E.	4-7	} FOR 440E.
L2		2-4-8		5-8	
L3		3-5-9		6-9	

THREE PHASE SLIPRING INDUCTION MOTOR.

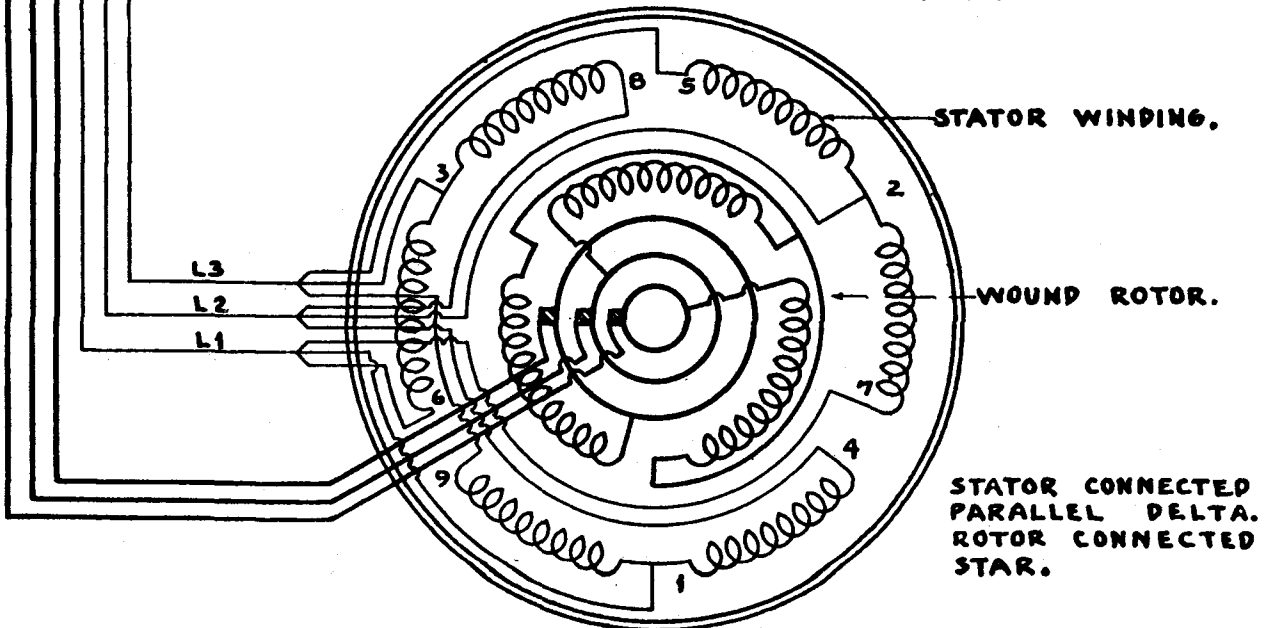

STATOR CONNECTED
PARALLEL DELTA.
ROTOR CONNECTED
STAR.

FIG. 1 FOR STARTING DUTY - (10 STEPS)
CONNECT AS BELOW.

MAX. RATING		
TYPE	MAX. SECONDARY	
	VOLTS	AMPS
YX	1000	200
ZY	1000	400

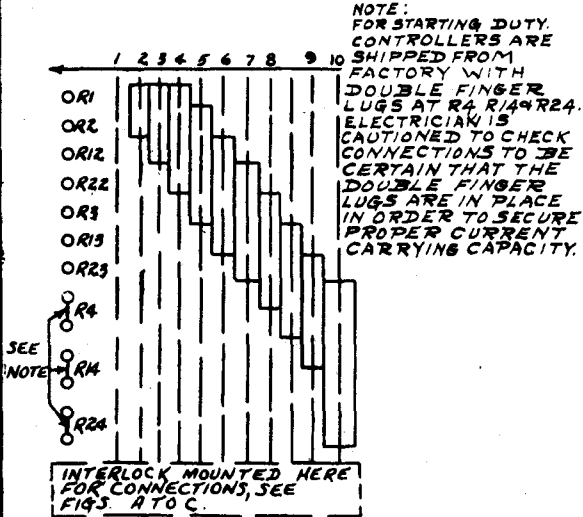
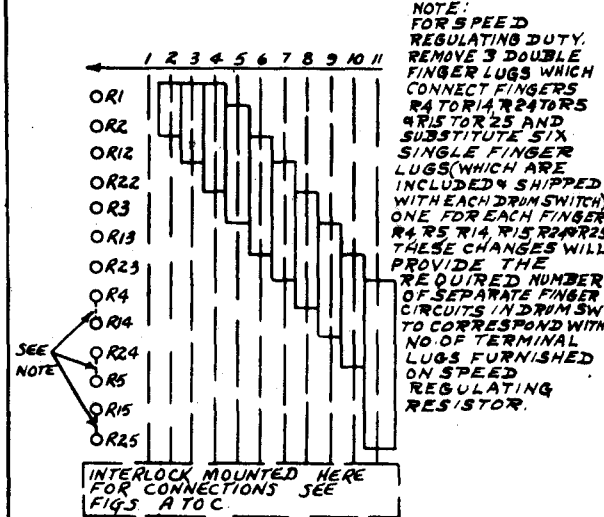

FIG. 2 FOR SPEED REGULATING DUTY - (11 STEPS)
CONNECT AS BELOW.

MAX. RATING		
TYPE	MAX. SECONDARY	
	VOLTS	AMPS
YX	1000	100
ZY	1000	200



WHEN INTERLOCK IS USED CONNECT TO MEET REQUIREMENTS IN ACCORDANCE WITH ONE OF THE DIAGRAMS BELOW

72822 D2

FIG. A FOR LOW VOLTAGE PROTECTION ON ALL POINTS EXCEPT POINT #1 WHICH PROVIDES LOW VOLTAGE RELEASE.

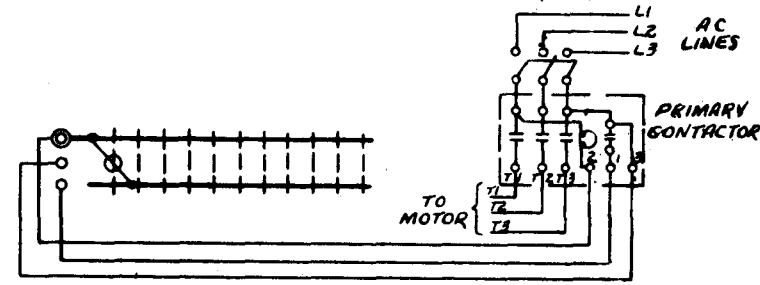

FIG. B FOR INTERLOCKING WITH PRIMARY MAGNETIC CONTACTOR COMPELLING STARTING FROM "OFF" POSITION - PROVIDES LOW-VOLTAGE PROTECTION ON ALL POINTS.

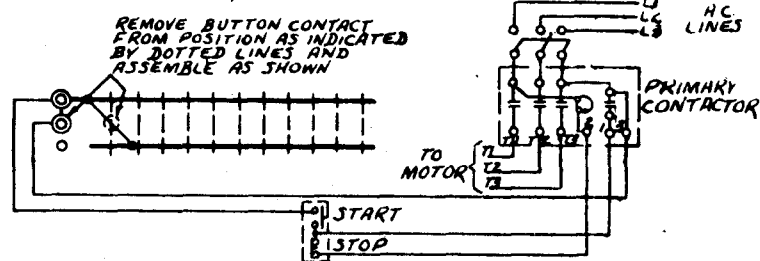
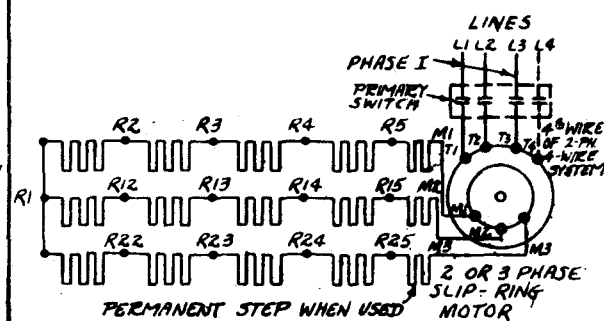
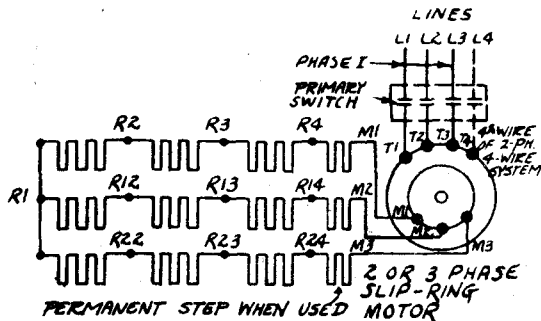
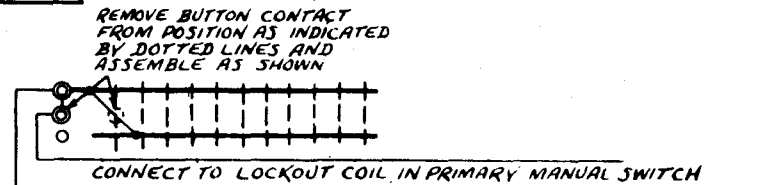

FIG. C FOR INTERLOCKING WITH PRIMARY MANUAL SWITCH



CONNECT RESISTOR TERMINALS SHOWN ABOVE TO CORRESPONDING FINGERS IN DRUM CONTROLLER

CONNECTIONS FOR AC NON-REVERSE SLIP-RING MOTOR DRUM CONTROLLER			
A	OMA 10-33	DRAWN BY M. MANIKOWSKI	9-20-34
B	OMA 10-34	TRACED BY R.D. McKeon	10-1-35
C	OMA 10-35	CHECKED BY [Signature]	9-20-35
D	OMA 10-36	APPROVED BY [Signature]	10-1-35
E	OMA 10-37		
F	OMA 10-38		

CUTLER-HAMMER, INC. MILWAUKEE NEW YORK

SELSYNS*

For Remote Signaling, Control, and Indication

SELSYN DEVICES

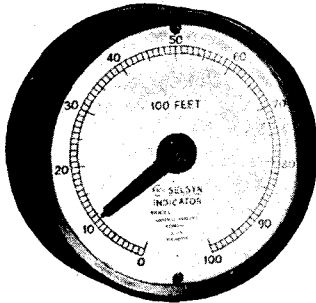

Standard-type level indicator

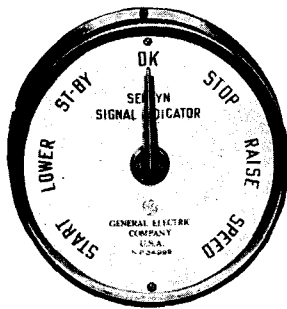

Standard-type signal indicator

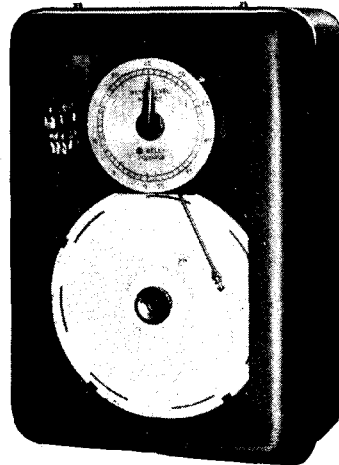

Combined indicator and recorder

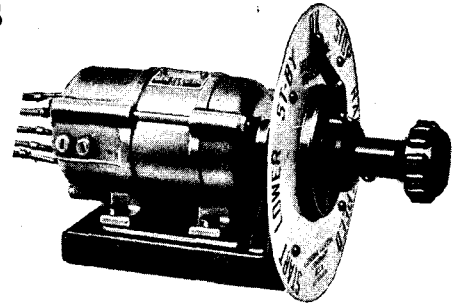

Selsyn transmitter

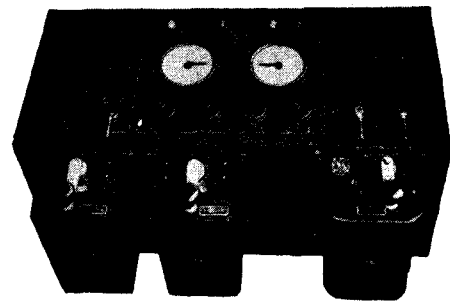

Control bench, with Selsyn indicators for double-basculer bridge

DESCRIPTION AND OPERATION

"SELSYN" is a General Electric trademark for self-synchronous devices. These devices are similar to 3-phase induction motors, but have two definite field poles, the windings of which are connected to a single-phase, alternating-current source of excitation. Two of these units are used in a simple Selsyn system. One is operated at the sending point as a generator and is called the transmitter; the other is operated at the receiving point as a motor and is known as the receiver. The secondary windings of the transmitter are connected to those of the receiver, as shown in the diagram below.

When the primary excitation circuit is closed, an alternating-current voltage is impressed on the primary of both the transmitter and the receiver. Since the receiver rotor is free to turn, it assumes a position similar to that of the transmitter rotor. As the transmitter is turned (either manually or mechanically), the receiver rotor follows at the same speed and in the same direction.

The reason for this self-synchronous action is because the single-phase current in the primary induces voltages in the three legs of each secondary. These three voltages are not equal in magnitude, and vary with the position of the rotor. When the two rotors are in exactly corresponding positions, the voltages induced in the transmitter secondary

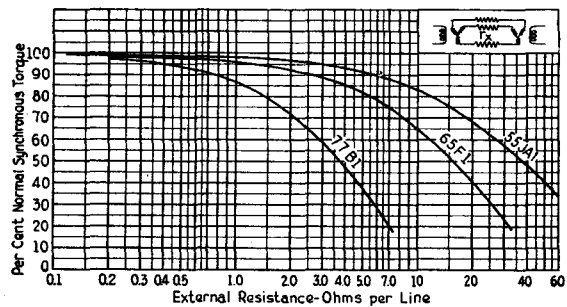

Torque-resistance curves

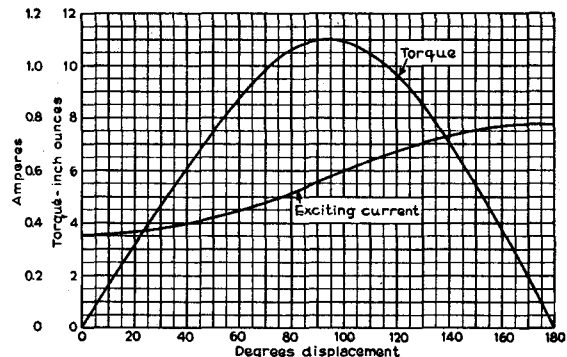

Type 2J55 Selsyn torque curve

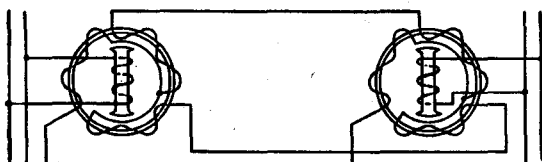

are equal and opposite to those induced in the receiver secondary; that is, they are balanced, so that no current flows in the secondary windings.

If, however, the transmitter rotor is moved from the original position, the induced voltages are no longer equal and opposite, and current flows in the secondary windings. This current flow sets up a torque which tends to return the transmitter rotor to its original position.

SELSYNS

FEATURES

Selsyns are strong and compact. There is no complicated assembly of parts that requires adjustment and there are no delicate parts to get out of order. An important characteristic of the Selsyn is its comparatively high torque, which prevents the indicator pointer from oscillating when it swings into position. An internal mechanical damper is furnished with the Selsyn receiver in order to prevent oscillation when synchronizing, and to overcome any tendency of the receiver to run as a motor. Features which make this system desirable for the service to which it is applicable are:

Reliability. All parts are designed for long life. High-grade ball bearings are used in the rotors to insure accuracy and to reduce maintenance. Collector rings and brushes are used to assure an uninterrupted flow of current.

Accuracy. Selsyns are exceptionally accurate because of a careful balance of electric and mechanical parts, and the use of low-friction bearings.

Continuous Indication. Operation of the indicator (motor) is definite and at all times in agreement with the transmitter (generator). The movement is smooth and continuous.

Instantaneous Response. The indicator responds immediately to the changes of position of the transmitter. There is no hesitation in starting. The transmitter moves, and the indicator follows instantly.

Self-synchronous. If power fails, the indicator is automatically reset in agreement with the transmitter on resumption of power. Necessity of removing the cover and resetting the rotor by hand and then checking back and forth with the transmitter is obviated.

Convenient Location. The indicator may be located wherever desired. It is small and compact, and may be mounted on a panel, pedestal, wall or desk, in brief, in the most advantageous position.

Ease of Installation. It is necessary only to bolt the devices in place and run a few wires.

Multiple Indication. When used for indication, one transmitter may be used with several properly sized indicators so that indication and signals can be made simultaneously at several places.

Selective Operation. For indication and signaling, one transmitter, if desired, can send to a number of indicators, one at a time. This is accomplished by a selector switch mounted with the transmitter.

Scope. Selsyns can be used to indicate either linear or angular movement. They can also be used to control, from a distant point, the motion of a device by controlling its actuating element.

Serviceability. The Selsyn system installed on the control boards of the Panama Canal locks is operating as efficiently today as when it was first operated in 1914.

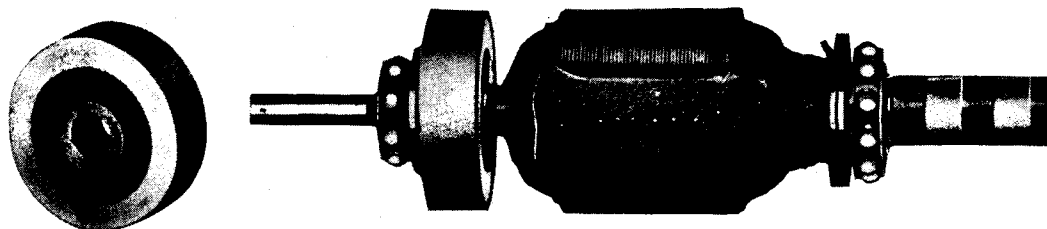

Wound rotor, with damper for Selsyn Model 2JD55JA1. Left: View of damper removed

TWO CLASSES OF SELSYNS

There are two general classes of requirements which Selsyns must meet: in some cases, it must be an exceptionally quiet unit of very high accuracy; but for general-purpose applications, an inexpensive, fairly accurate unit not having to meet stringent noise requirements may be acceptable. To meet the first requirement, the following Selsyns have been developed:

Instrument High Accuracy Type

2J55JA1. This model develops a maximum safe continuous operating torque of 2.7 in.-oz., which occurs at 20 degrees displacement. This unit has a primary winding suitable for 110-volt

excitation and a secondary winding developing 55 volts. The accuracy of this unit is tested at the factory and must be within the limits of ± 1 degree. The bearings are high-quality ball bearings, lubricated at the factory, and require but little attention in the field. The unit is totally enclosed, dustproof, and very compact, although extremely sturdy.

2JD55JA1. This model is identical with the 2J55JA1 except that it is equipped with an oscillation damper. This oscillation damper has a braking effect on the oscillations which may develop as a result of overshooting.

JUMPING RING LADDER ARC

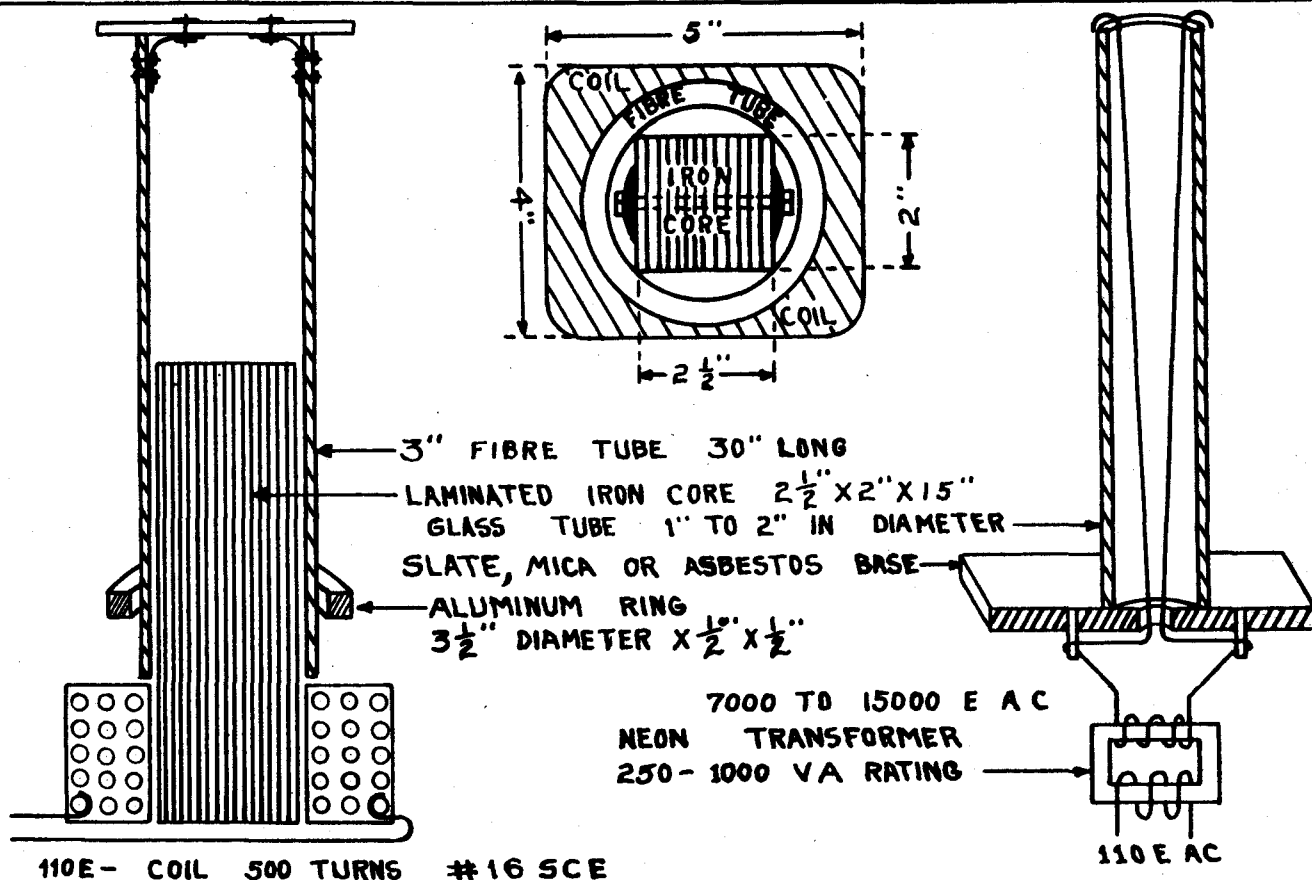

The electrically-operated display units shown above may be used to good advantage as window displays to attract the attention of prospective customers. The operation of these units is so novel and mysterious that any persons passing by a window where one or both are displayed will automatically stop to investigate. In doing so, they will naturally see other articles displayed, helping the owner to better advertise his merchandise. You might also make money by constructing these display units and selling or renting them to merchants or store keepers at a real profit.

The jumping ring should be mounted in a wooden box in such a manner that the transformer, switch and connections are below the top of the box, in order to conceal these parts. An intermittently-operated switch may be connected in series with the coil to give continuous operation. When the circuit is closed, the ring will be forcefully repelled by reason of heavy currents induced in it due to transformer action when the coil is energized. The circuit should remain closed for a few seconds, causing the ring to remain suspended without any apparent reason. It is this evident defiance of the law of gravitation which arouses the interest of a passer-by.

The ladder arc operates on the principle that electric arcs drawn in air between vertical wires will be driven upward by the rising heated air and by magnetic action. In the arrangement shown above, the arc is drawn at the bottom of the tube and travels rapidly to the top where the increasing arc length finally causes it to snap out. When this occurs, the arc is immediately re-established at the base and the cycle is repeated. Location of this device in a manner that will permit free circulation of air through the tube will result in improved operation by increasing the rate at which the arc travels.

The size of the transformer to be used with this device can be determined by experiment; however, a 1000 VA (9000 V) neon sign transformer will operate quite satisfactorily on a tube two inches in diameter. If a one-inch tube is used, a 300 to 500 VA transformer will be satisfactory. If the wires expand enough when heated to interfere with operation, a small coil spring may be inserted in each wire at the

HYDRAULICS.

PRESSURE IN A LIQUID

If a funnel, whose open end is covered with a stretched rubber diaphragm and whose other end is attached to a U tube partially filled with liquid, be immersed in a container of the same liquid, a difference in liquid level in the U tube will be observable, and this difference, which is a measure of the pressure applied to the diaphragm, will increase as the funnel moves deeper into the liquid. If the funnel be turned in any direction at any selected depth, conditions in the U tube will not change. This shows that a liquid exerts a pressure proportional to the depth, and that the pressure is the same in all directions.

TRANSMISSION OF PRESSURE

That the pressure in a liquid acts equally in all directions may be seen by the arrangement shown in Fig. B. When the entire vessel is filled with liquid. Upward motion of the piston P will cause all the spring loaded plungers to move by exactly the same amount. This property of liquids to transmit applied pressure equally in all directions was first discovered by Pascal and the statement that "pressure applied to a liquid at rest is transmitted equally in all directions" is known as Pascal's Law.

TOTAL FORCE = PRESSURE X AREA

Figure C shows two cylinders, one of small and one of large diameter, connected by a pipe and fitted with watertight pistons. If this system is filled with water and a force be applied to the small piston, the pressure created will be transmitted to the larger one. If the area of the large piston be ten times that of the other, ten times the force will be required on the large piston to prevent it from rising, that is, total force = pressure x area. This is the principle of the hydraulic press and hydraulic lift. This arrangement does not represent a gain in energy for A must move ten units of distance for each one unit traversed by B.

VENTURI METER

When a liquid such as water is flowing through a pipe, a drop in pressure takes place in the direction of flow as shown by the difference in height of the water columns in h_1 and h_3 . If a constriction be placed in the pipe as at 2, the increased velocity at this point will produce a further pressure drop as shown, a loss in head that is proportional to the amount of water flowing. This arrangement of constricted pipe and pressure indicators which provides a means of measuring the flow is called a venturi meter. When properly calibrated, the difference in pressure indicated by the difference in level of the liquid in the stand pipes h_1 and h_2 may be used as a means of determining the velocity of the liquid through the pipe, or the quantity of fluid flowing in a given time.

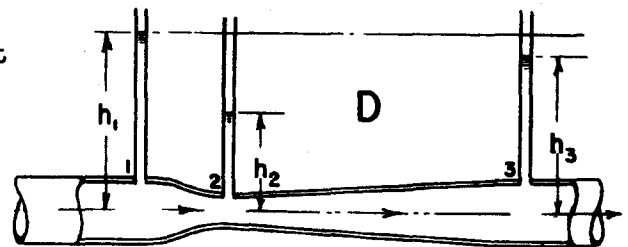
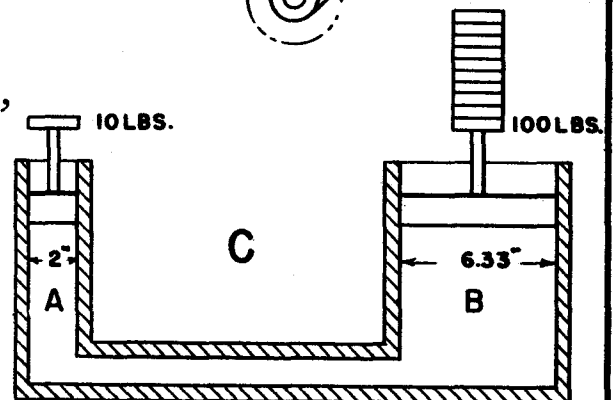
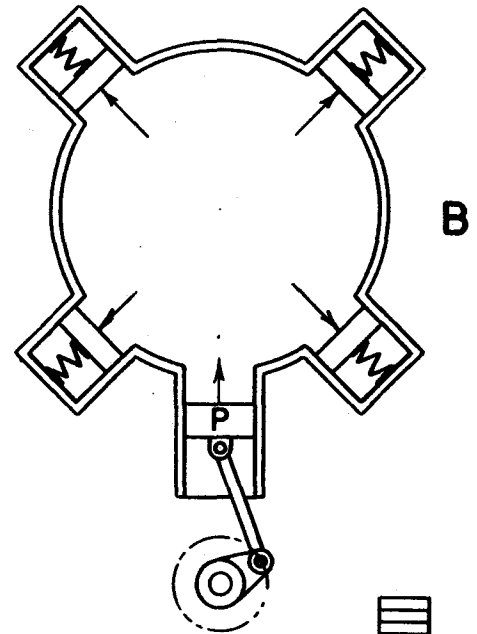
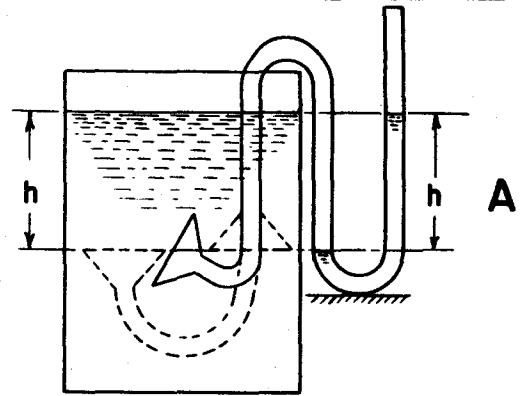

VARIABLE SPEED DRIVES.

CONE PULLEY DRIVE

Although most machines are designed to operate at constant speed, there are many types of drive that require a smooth variation in speed within the range for which the equipment was designed. Several drives of the continuously variable type have been developed, one of the simplest being the cone and pulley arrangement shown. The driving member and the driven member are connected by a movable belt which, in the diagram above, continuously increases the speed of the driven pulley as the belt is moved from left to right.

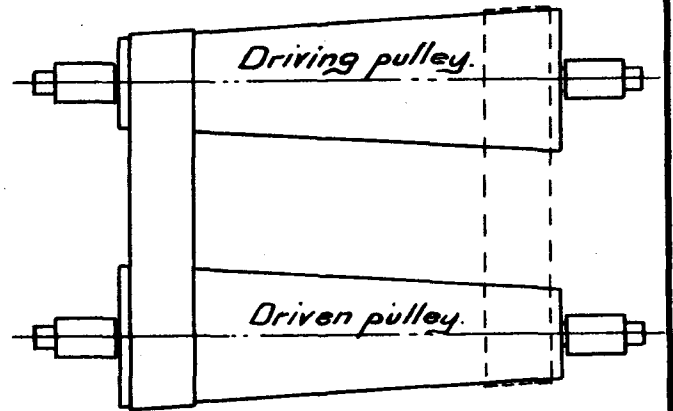

CONE PULLEY DRIVE.

DISC AND ROLLER DRIVE

This type of drive covers a much wider range of speed than the cone pulley arrangement shown above. Friction between the driving disc and the driven roller provides a means of speed variation that changes with the roller position. As the driven roller is moved from the center, its speed rises and attains a maximum when the outer edge of the driven disc is reached. Note that the driven roller reverses its direction when it passes across the center of the driven disc. Thus a wide speed change in either direction of rotation is secured.

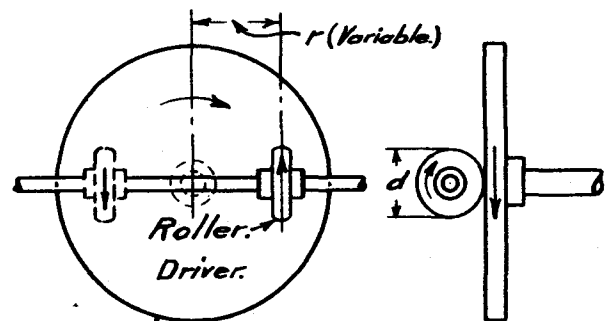

$$\frac{2r \text{ (R.P.M. of driver)}}{d} = \text{R.P.M. of roller.}$$

DISK AND ROLLER DRIVE.

DISK AND BALL DRIVE.

In principle, the disc-and ball drive is the same as the disc-and roller; however, the latter is a superior mechanical arrangement and the drive is more positive. The ball is partially enclosed in a cage so supported that it may be slid across the driving disc, the energy being transferred through the ball to the driven roller.

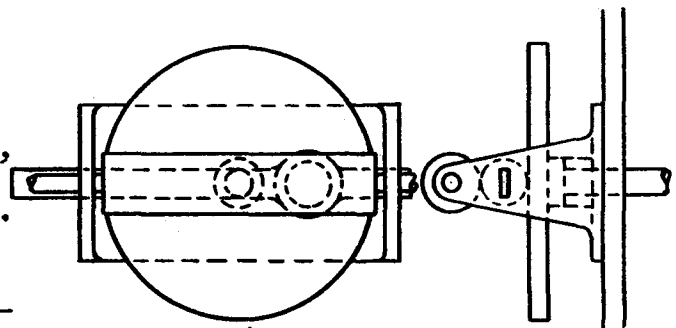

When the disc is driven at constant speed, this type of drive may be employed to provide wide speed changes on the driven roller with good speed regulation on each setting. The speed may be changed quickly and by any amount merely by sliding the ball across the disc. Reversal of rotation takes place when the ball passes the center of the driven disc.

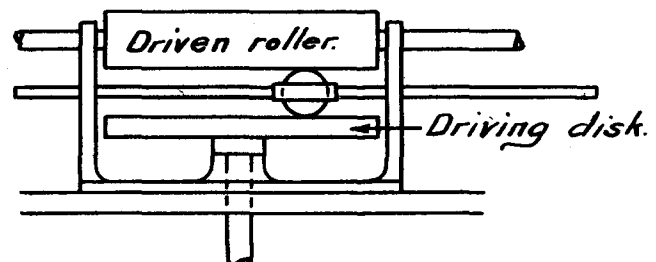

DISK AND BALL DRIVE.

DIFFERENTIAL DRIVES.

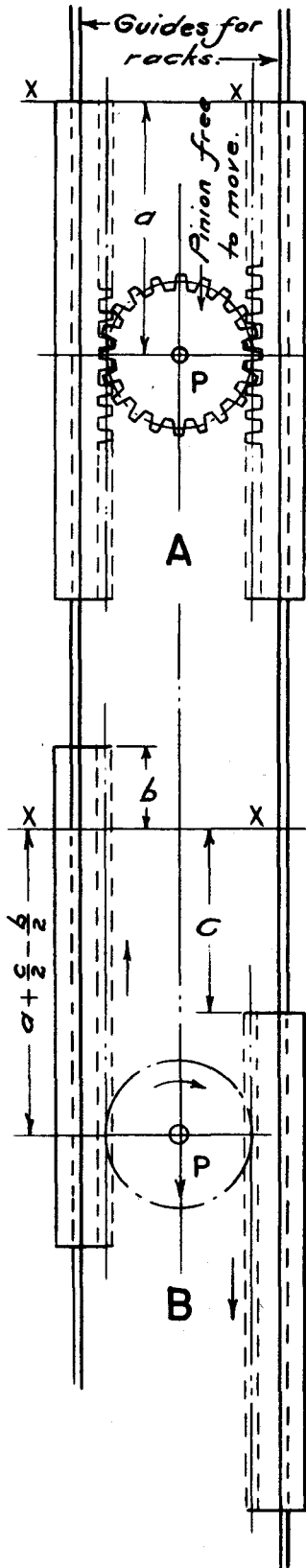

Although gears and gear drives are usually associated with transmission of power from one shaft to another, there are many applications in which the gear assembly is designed to fulfil some other purpose as well. For example, one gear may be so arranged with respect to others that, in moving, it may travel through a distance that may represent the sum, or the difference, of the motions of the gears with which it is meshed.

Figures A B C D are designed to show how the revolution and travel of the pinion P is affected by the motions of the two racks with which it is meshed.

If in figure A the racks R are moved up at the same speed, the pinion P will not revolve but will move bodily in the same direction and by the same amount.

Figure C shows what happens when one rack is held stationary and the other moves down. Here the pinion P will both revolve and move downward, the motion of the pinion being equal to one-half the distance through which the rack R is moved.

In figure B both racks are moved, one traveling upward while the other moves downward; moreover, the right hand rack is presumed to move through twice the distance traversed by the left hand rack. Under these conditions the pinion will move downward through a distance that is proportional to the difference in the distances traveled by the racks.

If the downward moving rack traverses a greater distance than the upward moving one, the pinion motion will be downward and the distance moved by it will depend upon the difference in the two rack motions.

If the racks move equal distances but in opposite directions, the pinion will revolve but it will not move up or down. This condition is shown in D.

Evidently the racks may be moved at any speed and through any distance with respect to each other and the pinion will travel through a distance and in a direction that is proportional to the algebraic sum of the rack motions.

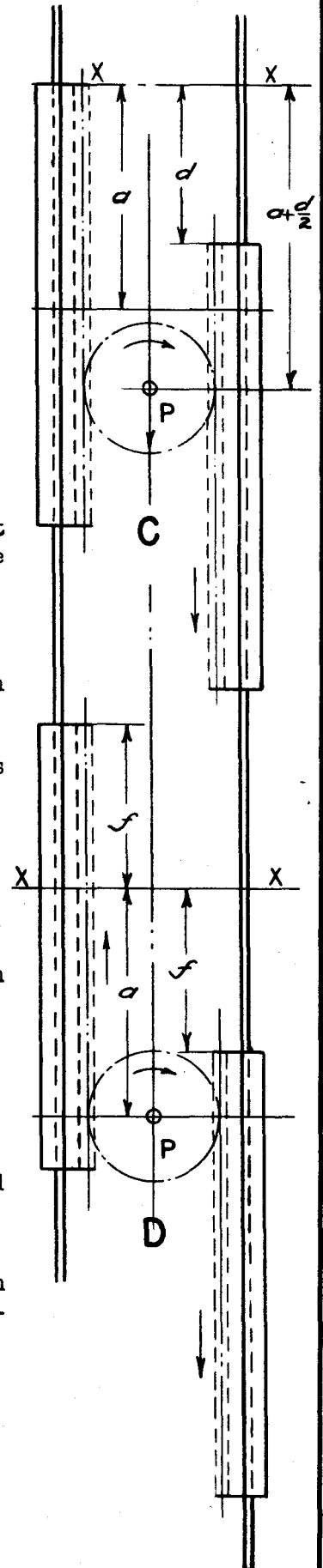

GEARS AND CAMS.

DIFFERENTIAL GEARING

If the racks previously illustrated be assumed bent in a circle and mounted on shafts 1 and 2, the rack and pinion motion is communicated to gear 4 through gear 3. This gear assembly will provide, in gear 4, a number of revolutions that is proportional to the algebraic sum of the revolutions of gears 1 and 2.

If shaft and gear 1 be turned through one revolution forward while shaft and gear 2 is turned at the same rate through one revolution backward, pinion P will revolve but will not move gear 3, for the algebraic sum of these two motions is zero. For any other motions of gears 1 and 2 shaft 4 will move, and the motion will always be PROPORTIONAL to the motions of shafts 1 and 2.

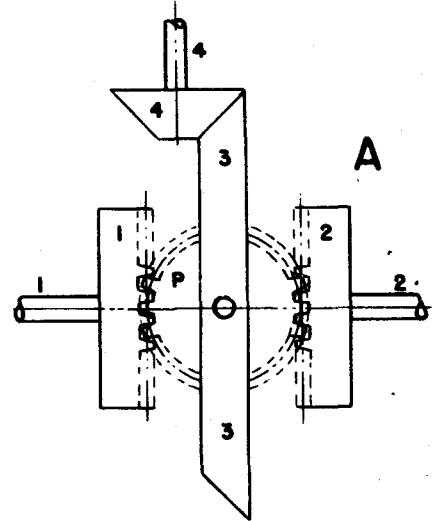

EPICYCLIC GEARING

In the ordinary gear train, two toothed wheels, rigidly keyed to separate shafts, are meshed together. If Y in figure B is assumed to be connected to the driving mechanism and revolving counter-clockwise, gear X will rotate clockwise with a velocity proportional to the gear ratio; in this case 2:1.

In the epicyclic gear train one gear rolls around the other. For example, if the toothed wheel X is allowed to revolve freely on its axis and is attached to the arm shown in Fig. B, and if this arm be revolved about the fixed gear Y, it will be found that in describing one revolution about Y that X has turned through a number of revolutions equal to epicyclic type, a greater change in r.p.m. may be obtained with a given set of gears.

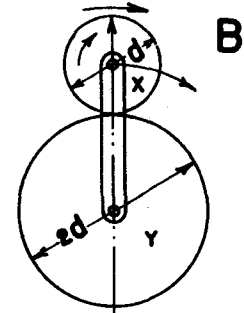
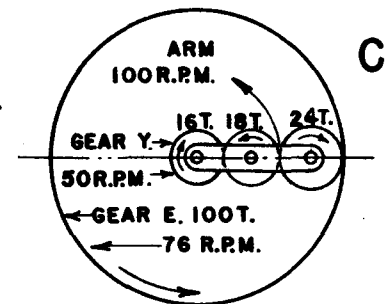
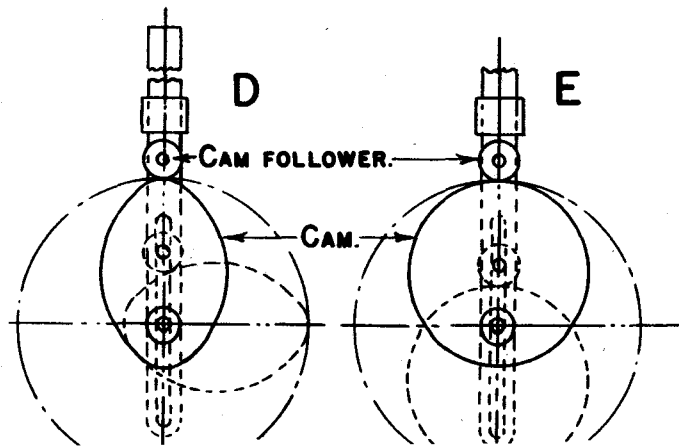

Figure C shows another epicyclic train in which Y is the driven gear and E is the external ring gear. If the separate gears possess the number of teeth indicated, and the arm A turns at 100 r.p.m. clockwise, the external ring gear will rotate through 76 r.p.m. counter clockwise. Besides being more compact, this type of gear assembly is better adapted to certain gear problems. The differential gear trains shown in A above is really an epicyclic arrangement.



CAMS AND THEIR APPLICATION

Translation of rotary to reciprocating motion may be accomplished by means of rack and pinion gearing, crankshaft and connecting rods, or by cams and cam followers. If the cams shown be rotated beneath the followers indicated, the latter will be caused to move up and down with a velocity proportional to the shape of the cam, thus by suitably shaping the cam, the follower may move with a velocity that, with a constant r.p.m. of the cam shaft, is governed only by the shape of the cam itself.



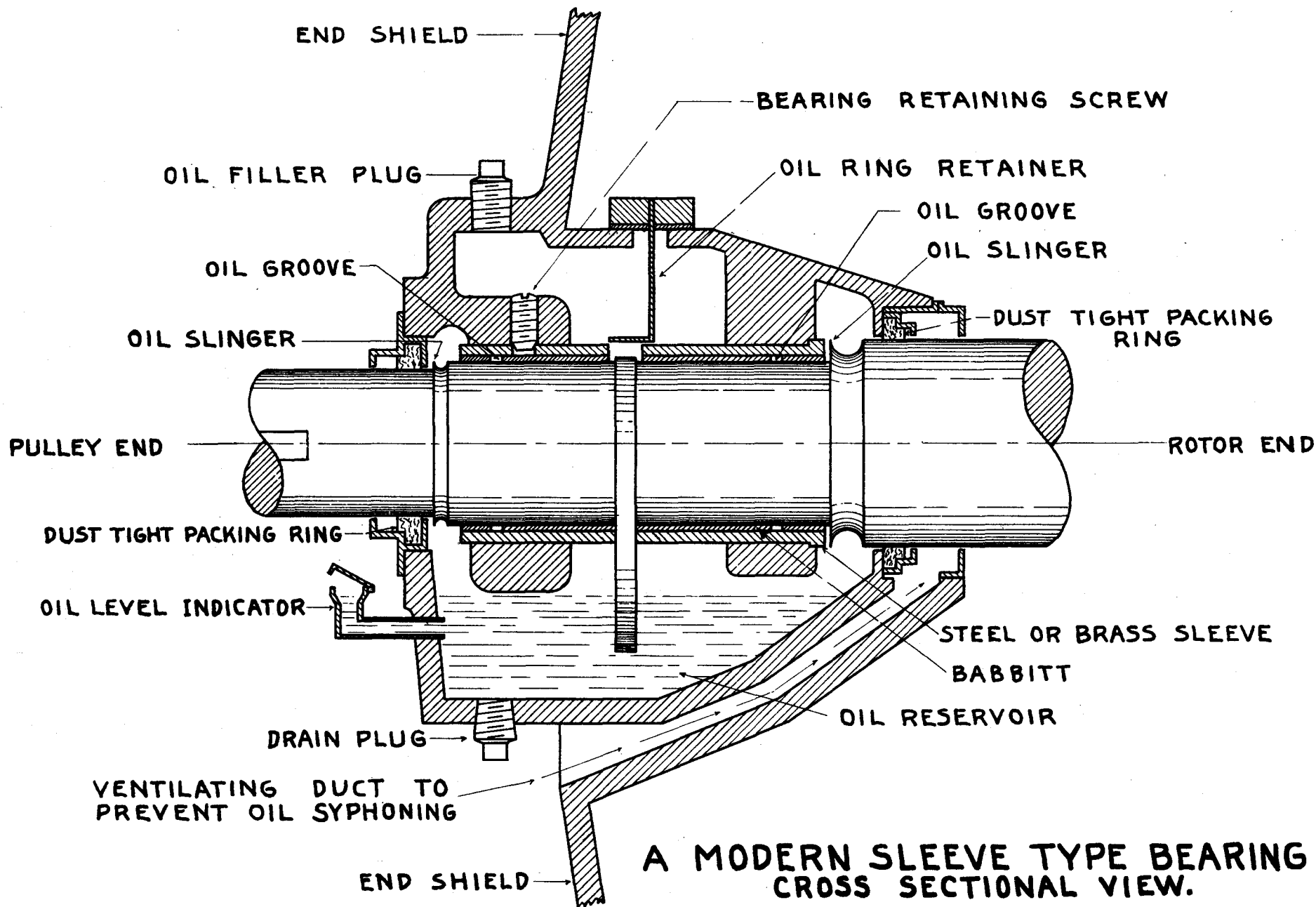

**A MODERN SLEEVE TYPE BEARING
CROSS SECTIONAL VIEW.**

A.C. MotorNameNumber

1. Clean any dust, dirt or oil from frame and metal parts
2. If ventilating ducts in winding are clogged, clean carefully
Do not damage insulation.
3. Check shaft, duct seal at both sides of bearing, Good.....Bad.....
4. Oil leaks at bearings, Leaky.....No Leaks.....
5. Oil Well Covers O.K.....Defective.....Missing.....
6. Oil Well Drain O.K.....Leaky.....Oil Good.....Poor.....
7. Oil level as shown by indicator Full.....low.....
8. With motor running does wither bearing heat Pulley end.....Opposite end.....
9. Bearing retaining screw (See bearing diagram) Tight.....Loose.....
10. Shaft end play Measure and state amount.....
11. Oil Rings Turn freely.....Sticking.....
12. If pulley or gear Tight.....Loose..... Motor vibrates Yes.....No.....
13. Key way Good.....Worn.....Key Good.....Worn.....
14. With motor running note any unusual noise Quiet.....Noisy.....
15. Run motor single phase and note sound and behavior.
16. Connections and Lugs Loose.....Tight.....Unsoldered.....
17. Bare wires touching frame.....none.....one or more.....
18. Condition of stator winding.....(A) Condition of insulation Good.....Bad.....
(B) Oily.....Dry..... (C) Caked Grease Yes.....No..... (D) Bare conductors
Yes.....No..... (E) Poor taping Yes.....No..... (F) Loose connections
Yes.....No..... (G) Clearance between rotor and stator or poles, (pulley end)
check with air gap gauge and mark measurements Top.....Bottom.....
Right side.....Left side.....
19. If machine has wound rotor check for: (A) Condition of insulation Good.....
Bad..... (B) Oily.....Dry..... (C) Caked grease and dirt on windings Yes.....
No..... (D) Bare conductors Yes.....No..... (G) Solder thrown from connections
Yes.....No..... (H) If machine has commutator, is brush setting correct Yes.....
No..... (I) Brush pig tails Loose.....Tight..... (J) Brush gear, Mechanical
condition of holders Good.....Bad..... (K) Brushes, Poor Contact Yes.....
No..... (L) Brush sticks in holder Yes.....No..... (M) Brushes too loose in
holders Yes.....No..... (N) Brushes too long Yes.....No..... Too short
Yes.....No..... (O) Slip rings pitted or worn.....Out of Round.....Dirty.....
Poor insulation..... (P) Brush Spring tension Even.....uneven.....too much....
O.K.....Too little..... (Q) Slip rings to rotor connections O.K.....Poor.....
(R) If machine has commutator is it O.K.....Dirty.....High Mica..... (S) Band
wires tight.....Loose..... (T) Squirrel cage rotor bars Tight.....Loose or
thrown solder.....

STARTING EQUIPMENT

20. (A) Loose connections Yes.....No..... (B) Contactors clean and well fitted....
Pitted.....Dirty.....Worn..... (C) Spring tension on contactors Equal.....
Unequal..... (D) Do all contactors make contact at the same time Yes.....No..... (E)
Does magnet holding arm, line up squarely with magnet poles Yes.....No.....
(F) What type of overload relay is used Thermo.....Magnetic.... (G) Condition
of trip contacts Good....Bad.... (H) If time relay is used is it mechanical....
or magnetic..... (I) If time relay is used is its condition Good.....Bad.....
(J) Are interlocking contact switches in Good....or Bad....condition (K) Does
starter use a mechanical interlock Yes.....No.....(L) Are any mechanical parts
loose Yes.....No..... (M) Are starting or holding magnets Noisy....Excessive
Magnetic hum,...Quiet.... (N) are shading coils used on magnets Yes.....No.....
(O) Make a note of anything unusual in starter operation.

CONSTRUCTION DETAILS FOR SIMPLE GROWLER

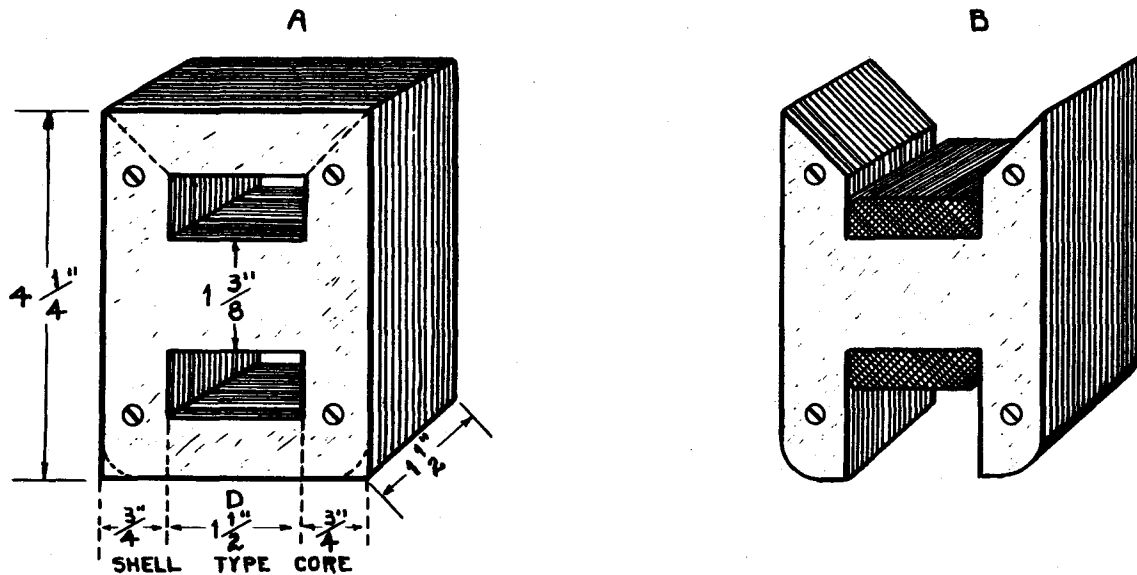









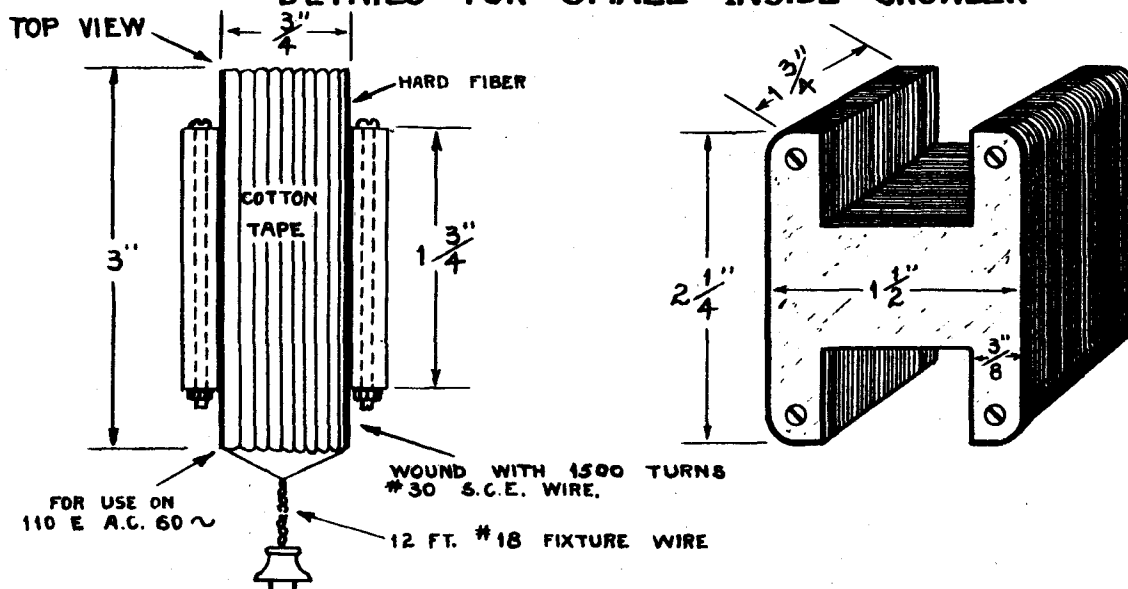

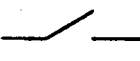
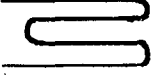

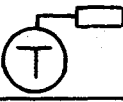



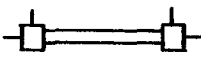

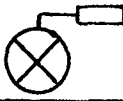

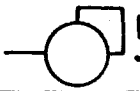

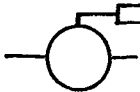

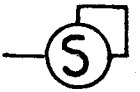

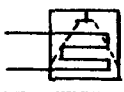

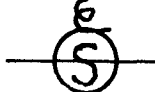

To make the above growler, secure the core of a burned-out, 100 watt radio-power transformer or bell transformer and remove the old winding, preserving the core insulation if possible. Next, trim the laminations along the dotted lines so that, when reassembled, they will have the form shown in "B", and approximate the dimensions given in "A". With some cores, it will be necessary to snip a section from the middle leg of the transformer in order to obtain the proper distance (D) between the sides. After the laminations have been cut, the core is restacked and clamped with the same bolts and brackets that were used in the original assembly; then the cut edges of the laminations are ground or filed to the desired smoothness. The core is then insulated with suitable material (filler board, fiber, fish paper, etc.,) and the winding installed.

The winding used will depend upon the voltage and frequency employed. Assuming a 60 cycle frequency, the number of turns for the different voltages are as follows: For 32E, 170 turns of #18 SCE; 110E, 500 turns of #22 SCE; 220E, 1000 turns #25 SCE.

Construction details for an inside growler, suitable for fractional h.p. motors, is given below.

DETAILS FOR SMALL INSIDE GROWLER

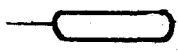

STANDARD REFRIGERATION SYMBOLS	
 DISCONNECT SWITCH	 PIPE COIL
 THERMOSTAT (SELF CONTAINED)	 FORCED CONVECTION COOLING UNIT
 THERMOSTAT (REMOTE BULB)	 IMMERSION COOLING UNIT
 PRESSURESTAT	 ICE MAKING UNIT
 HAND EXPANSION VALVE	 HEAT INTERCHANGER
 AUTOMATIC EXPANSION VALVE	 CONDENSING UNIT AIR COOLED
 THERMOSTATIC EXPANSION VALVE	 A. C. MOTOR
 EVAPORATOR PRESS. REGULATING VALVE THROTTLING TYPE	 D. C. MOTOR
 EVAPORATOR PRESSURE REGULATING VALVE, THERMOSTATIC THROTTLING TYPE	 ONE LINE } FUSE COMPLETE }
 EVAPORATOR PRESSURE REGULATING VALVE, SNAP-ACTION VALVE	 COOLING TOWER
 COMP. SIDE EVAPORATOR PRESS. REGULATING VALVE, THROTTLING TYPE	 EVAPORATIVE CONDENSER
 HAND SHUT OFF VALVE	 SOLENOID VALVE
 DRIER	 PRESSURESTAT WITH HIGH PRESSURE CUT-OUT
 STRAINER	 COMPRESSOR
 HIGH SIDE FLOAT	 SCALE TRAP
 LOW SIDE FLOAT	 CONDENSING UNIT WATER COOLED
 GAUGE	 THERMAL BULB
 FINNED TYPE COOLING UNIT	

TROUBLE DIAGNOSIS

Do not attempt to make any service adjustment on the system if temperatures are still satisfactorily maintained and pressures are within the normal operating range.

The following notes given details and hints that will be of help in locating trouble.

UNIT WILL NOT START:

- Power shut off.
- Poor contact at wall socket.
- House fuse blown out.
- Burned out heater in overload relay.
- Defective electric switch.
- Defective motor.
- Broken wire.
- Refrigerator too cold.
- Motor fush blown out.

FREEZES WATER TO ICE, BUT FOOD COMPARTMENT NOT COLD ENOUGH:

- Heavy frost on evaporator.
- No air circulation in cabinet due to arrangement of food.
- High service factor caused by putting hot foods in refrigerator.
- Door gasketing worn out - worn hinges.

EVAPORATOR DEFROSTS BETWEEN CYCLES:

- Temperature control set too warm.
- Refrigerator in a cold room.
- Short of refrigerant.

RUNS TOO LONG - OFF A SHORT TIME.

- Control valve not functioning properly.
- Temperature control set too cold.
- Short of refrigerant.
- Air in condenser.
- Dirty condenser.
- Warm water in ice trays.
- Improper air circulation around unit.
- Poor door gasket, admitting heat
- Cabinet too close to radiator or stove.
- Plugged strainers and restricted liquid line.

HIGH POWER CONSUMPTION:

- Air in condenser.
- Short of refrigerant.
- Too much refrigerant.
- Control valve not functioning properly.
- Cabinet too close to radio or stove.
- Cabinet in direct rays of the sun.
- Low voltage. Tight belt.
- Dust in condenser fins.
- Loose belt.

OVERLOAD CUTS OUT CONTINUOUSLY:

- Wrong line voltage, or current.
- Low voltage.
- Tight compressor.
- High resistance short circuit in motor.
- Poor connection in junction box.
- Too much refrigerant in the system.
- Too much oil in the compressor.
- High back pressure.
- Defective electric switch.
- High head pressure.
- Air in system.
- Centrifugal switch contact poor.
- Tight belt.
- Dust in condenser fins.

CABINET COLD BUT WATER WILL NOT FREEZE:

- Control valve not functioning properly.
- Too much ice in tray sleeve.
- Temperature control not set properly.
- Cabinet in too cold a place where unit does not run enough.

RUNS ALL THE TIME - NO REFRIGERATION:

- Control valve not functioning properly.
- Air in condenser.
- Short of refrigerant.
- Inefficient compressor.
- Air leaking into cabinet.
- No circulation of cool air through the condenser.
- Loose belt.

LEAKS - CAUSED BY

- Cracked tubing.
- Cracked connections.
- Loose connections.
- Loose cylinder head.
- Loose service valves.
- Blown gaskets.
- Broken seal bellows.
- Burned out seal bearings.
- Sand hole in casting.
- Corroded solder joints in evaporator.

FROSTED SUCTION LINE:

Low side float: leaky needle valve,
Stuck open float, moisture in the
system.

High side float: Overcharge of
chemical.

Leaky needle valve.

Automatic Expansion Valve: Out of
adjustment, moisture in the system.

Thermostatic Expansion Valve: Out of
adjustment, power bulb loose in holder:
Moisture in system.

NOISY UNIT:

Loose belt.

Loose pulley or flywheel.

Belt squeak.

Loose fan.

Too much refrigerant.

Too much oil.

Not enough oil.

Weak springs on flapper valve.

Surging power supply.

Oil missing from around bellows in
seal, causing it to vibrate.

Spring or rubber cushion missing.

Frame striking cabinet.

Vibrating tubing. red

Shipping bolts (painted aluminum) not
yellow

removed.

Loose bolts on frame.

TWO TEMPERATURE REFRIGERATORS

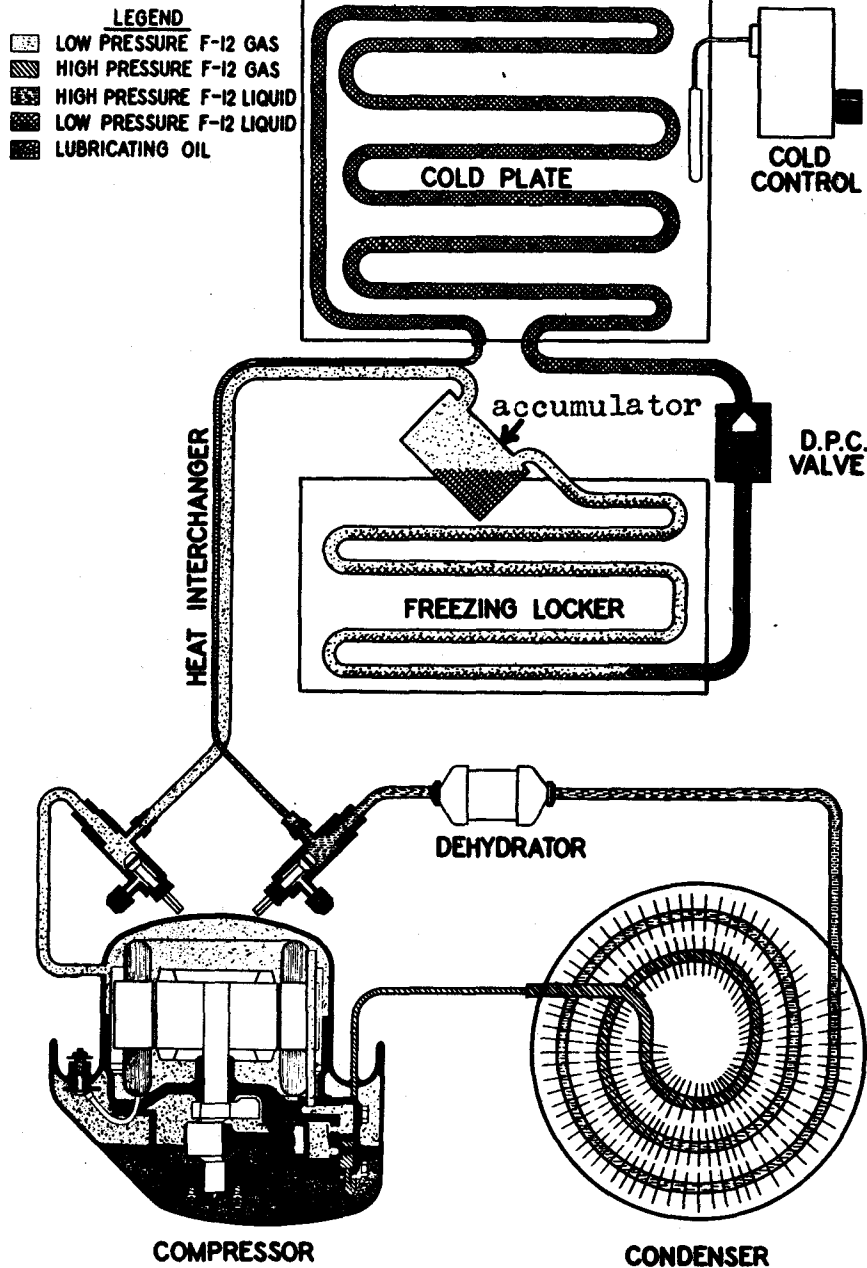

There have been several two temperature domestic refrigerators placed on the market. They employ the use of two separate evaporators with quite a wide variation in temperature maintained in each. One evaporator is usually placed in the wall of the cabinet in the main food compartment. The refrigerant temperature in this evaporator is maintained at approximately 28 F. The other evaporator is located in a frozen food compartment and contains the ice cube trays. The refrigerant temperature in this evaporator is maintained at about -5 F.

The above diagram illustrates the principle of operation of these units. After the refrigerant is liquefied in the condenser it passes thru the dehydrator and capillary tube where it is reduced in pressure to conform to approximately a 28 boiling point as it enters the food compartment evaporator. Part of the

liquid will evaporate here to maintain the food compartment temperature. The remainder of the liquid and low pressure gas passes thru the Differential Pressure Control (D.P.C.) valve into the freezing compartment evaporator. This valve further restricts the flow of the refrigerant and produces about a 20 lb. pressure drop. The liquid in the second evaporator under a lower pressure thus has its boiling point reduced to about -5 F. and maintains a lower evaporator temperature. This inique arrangement gives us two different temperatures in the same refrigerating system.

From the second evaporator where the remaining liquid evaporates the low pressure gas passes thru the accumulator and suction line to the evaporator. As noted in the diagram the accumulator is located at the outlet of this second evaporator. The accumulator traps any liquid which may be carried thru with the gas and thus prevents it from entering the suction line until it has completely evaporated.

CYCLE OF REFRIGERATION

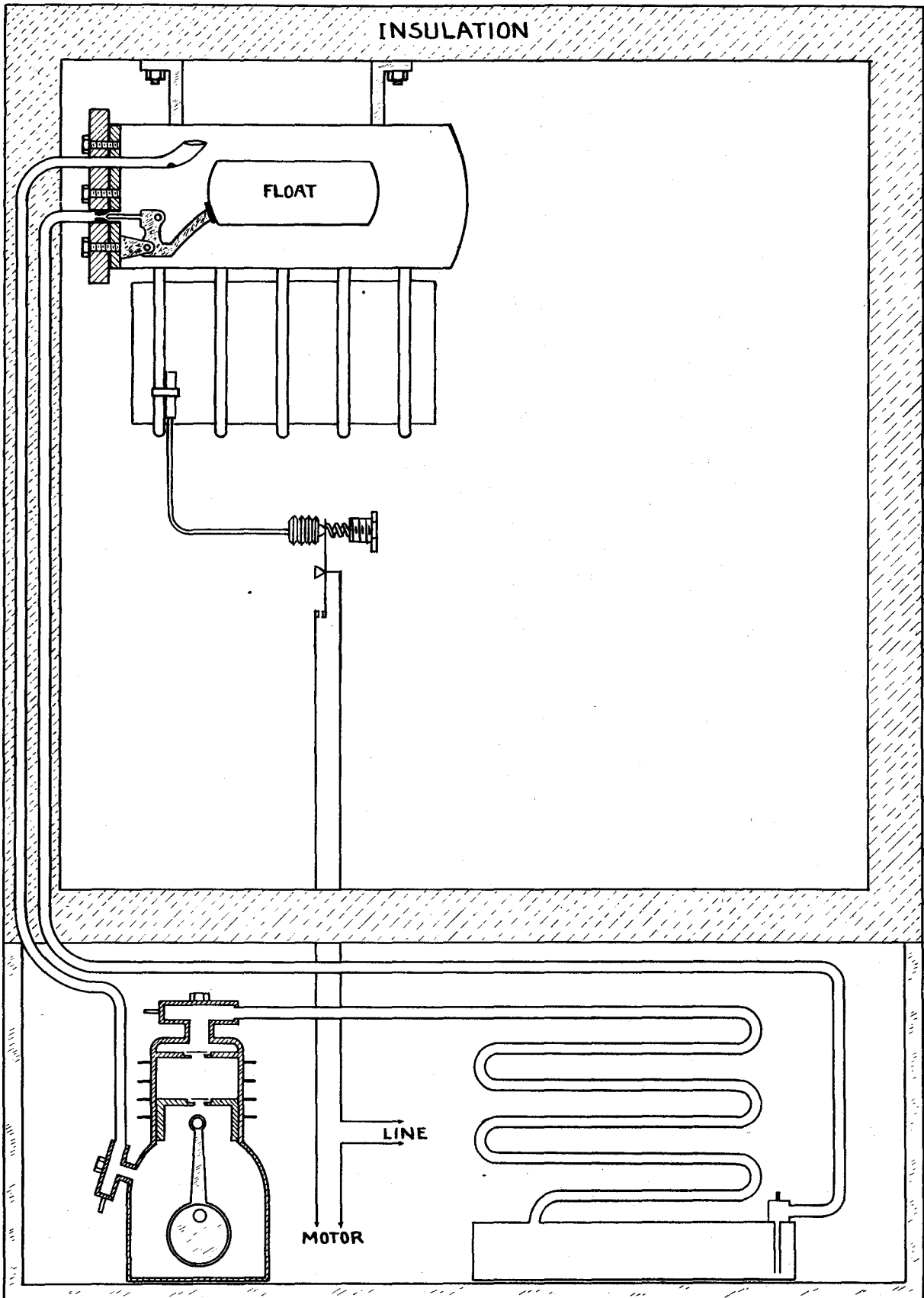

COMPRESSOR

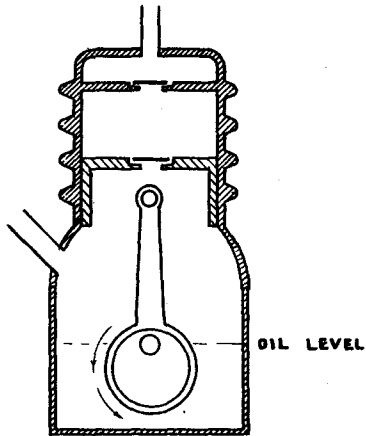

RECIPROCATING, SINGLE CYLINDER, SINGLE ACTING, REED SUCTION VALVE, REED DISCHARGE VALVE, SPLASH OIL SYSTEM.

COMPRESSOR

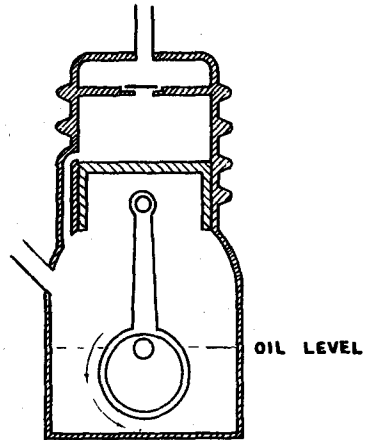

RECIPROCATING, SINGLE CYLINDER, SINGLE ACTING, PORT SUCTION VALVE, REED DISCHARGE VALVE, SPLASH OIL SYSTEM.

NORGE "ROLLATOR"

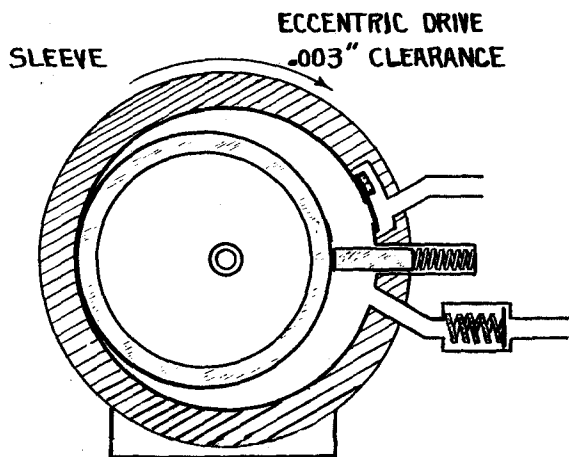

SYLPHON BELLOWS SHAFT SEAL

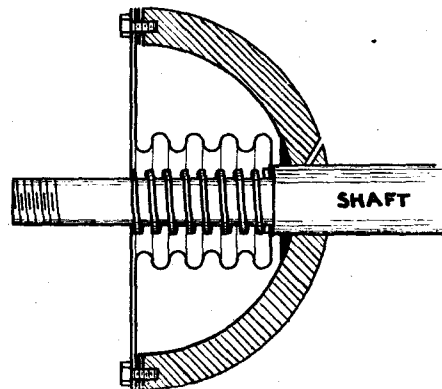

ROTARY VANE

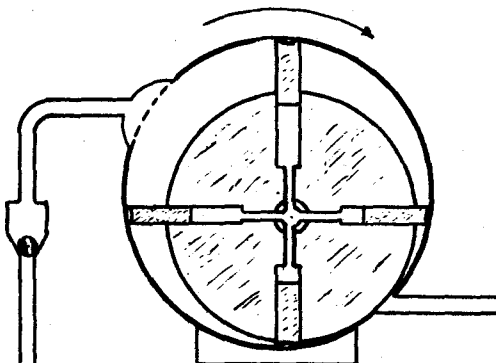

MAJESTIC ROTARY

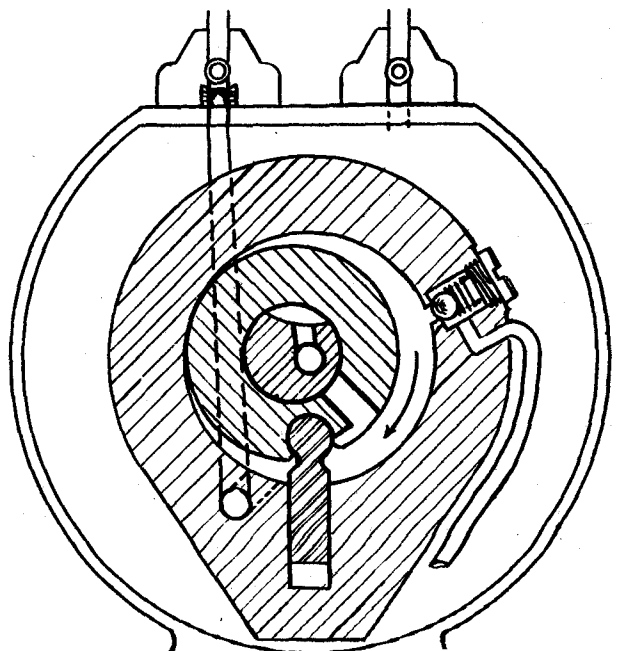

CONDENSERS .

PLAIN TUBE

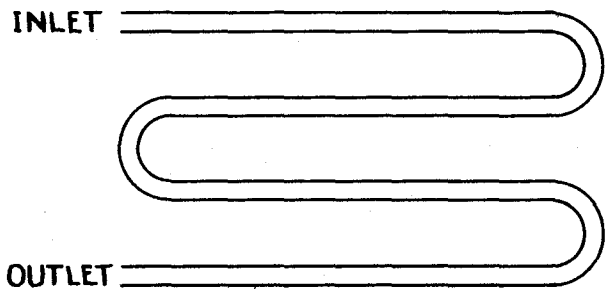

AIR COOLED TYPE

FIN TUBE

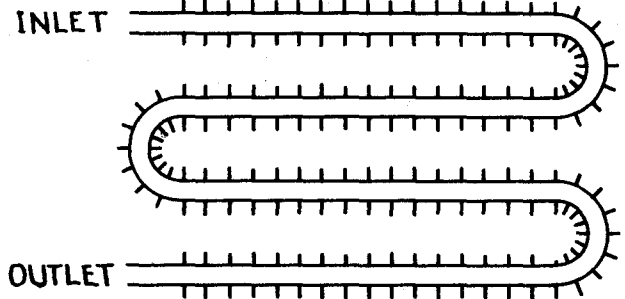

AIR COOLED TYPE

RADIATOR

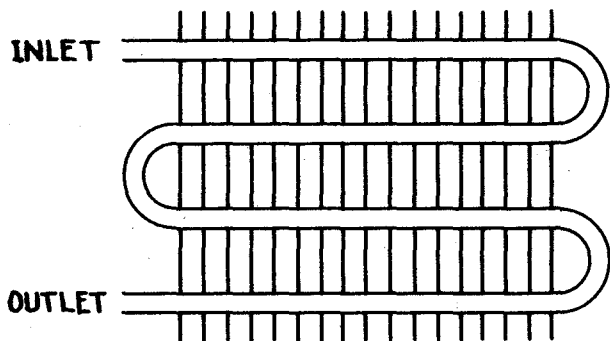

AIR COOLED TYPE

DOME TYPE

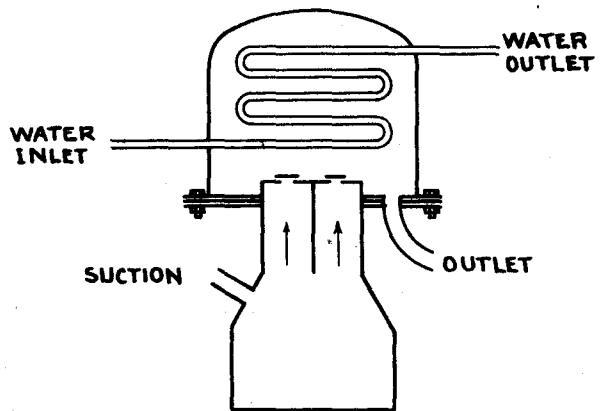

WATER COOLED

SHELL AND TUBE

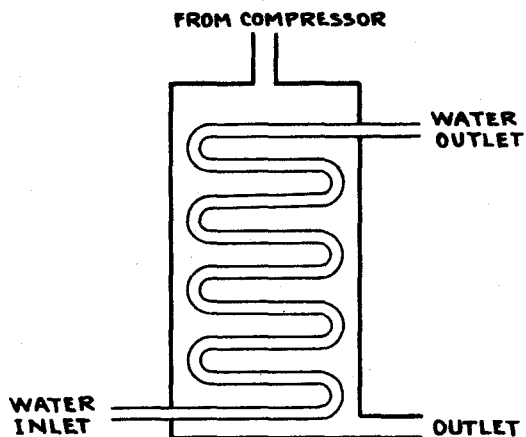

WATER COOLED

COYNE

DOUBLE TUBE OR COUNTER FLOW

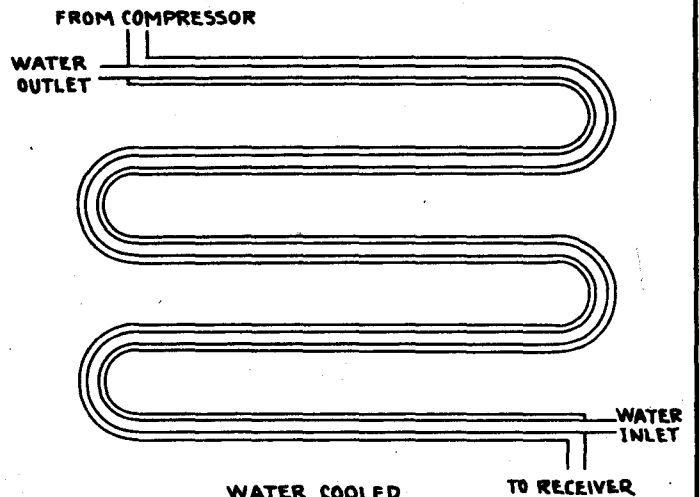

WATER COOLED

TO RECEIVER

LOW SIDE FLOAT-HIGH SIDE FLOAT

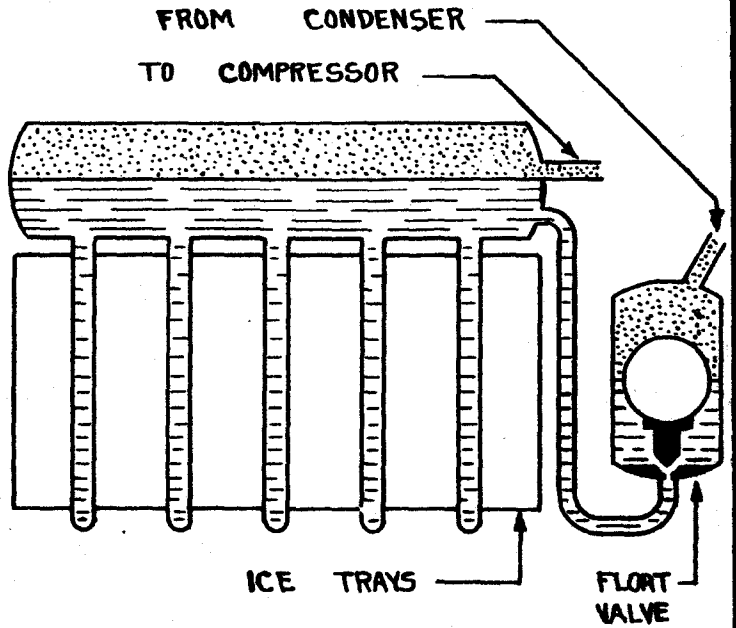
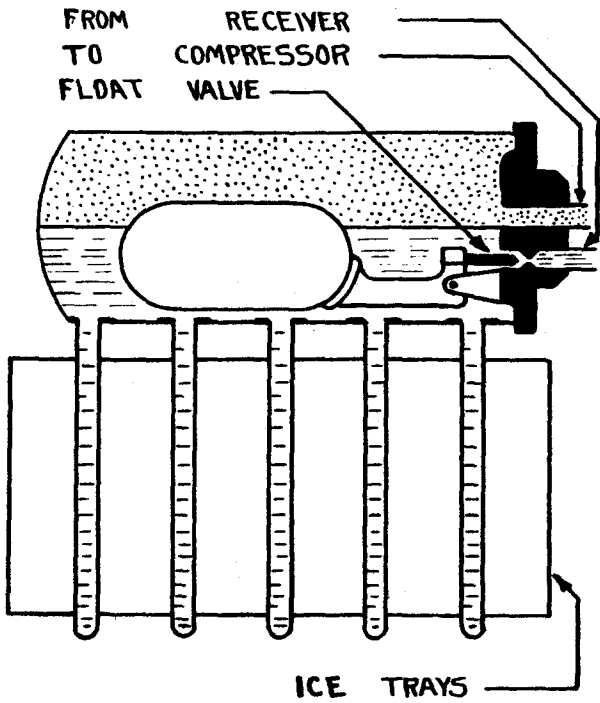

DRY DIRECT EVAPORATOR

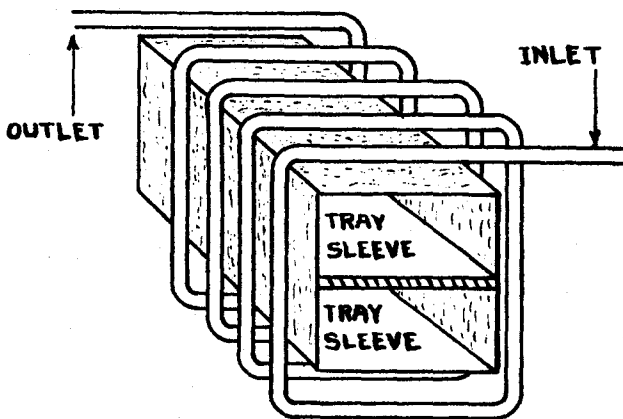

DRY INDIRECT EVAPORATOR

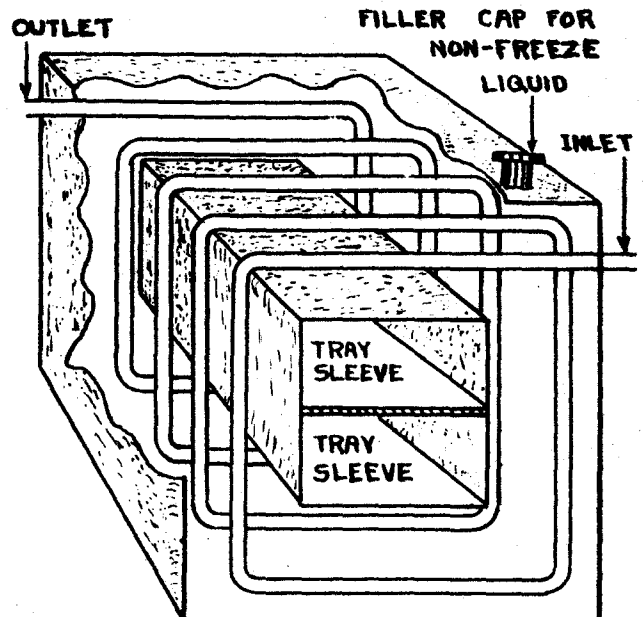

Low Side Float Valves

Float Valve Showing Needle Construction

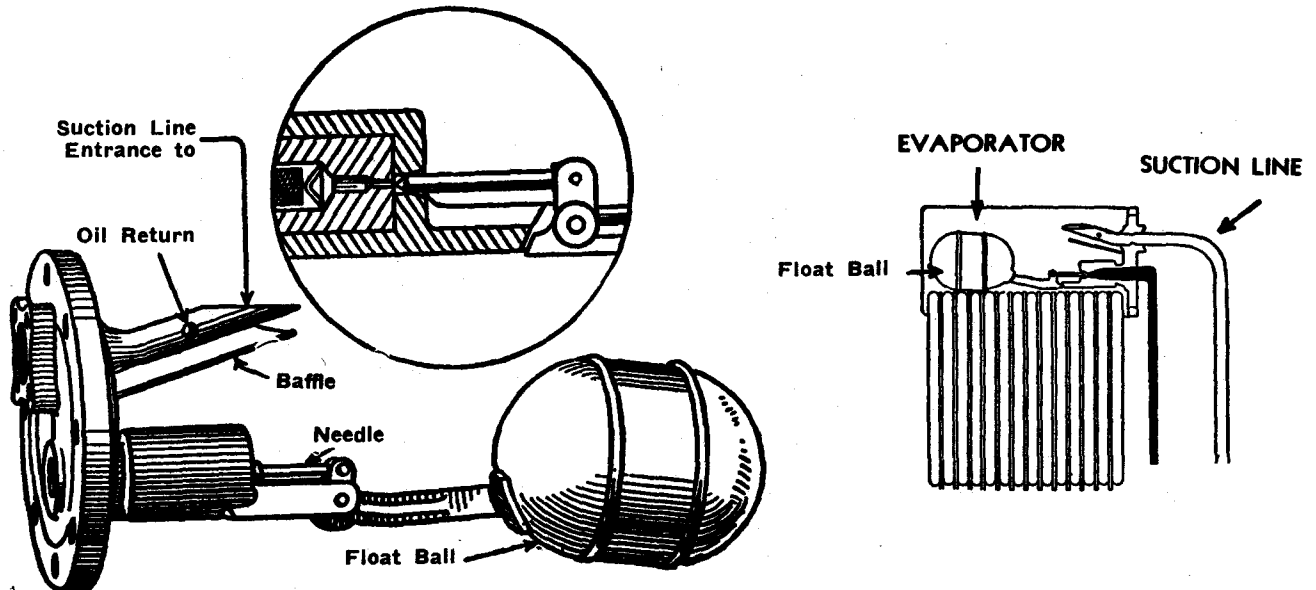

OIL BOUND EVAPORATORS

An oil bound evaporator may be caused by the compressor slugging through an excess amount of oil. The float assembly is designed to return a certain amount of oil which naturally circulates through the system, but when the amount of oil coming through becomes excessive it is not returned fast enough and the oil tends to replace the refrigerant. The trouble in the compressor may be caused by oil baffles being out of place or the trouble may be in the design of the compressor. In this case the condition may be remedied by placing an oil separator or trap in the compressor outlet.

The trouble may also be caused by an overcharge of oil in the system.

If the float is out of calibration so that the float rides too low, oil will tend to accumulate in the evaporator, and this condition may also cause the evaporator to become oil logged.

After the cause of this trouble has been remedied, the oil may be returned from the evaporator by placing hot water in the ice cube trays. A more positive means would be to remove the evaporator and dump the oil out. If this is done the oil level in the compressor should be checked to make sure it has sufficient oil.

When overhauling a low side float system, the proper amount of oil should be placed in the evaporator.

The normal oil charge carried in these evaporators should be obtained from manufacturers specifications whenever these are available. Otherwise a good general rule to follow is to add from 4 to 6 ounces of oil to the average household evaporator. For larger evaporators increase this amount in proportion to the size of the float header.

TROUBLE CHART FOR LOW SIDE FLOATS

TROUBLE	SYMPTOM	REMEDY
1. Plugged strainer or valve orifice	Starved evaporator — little or no refrigeration	Clean or replace strainer — Clean or replace orifice
2. Oil bound evaporator	Evaporator only partially frosted — Loud thumping noises in evaporator	See notation under diagram on front of sheet
3. Corroded valve needle or seat	Valve leaking and causing frost-back on suction line at the start of the running cycle	Replace needle valve and seat
4. Worn needle or seat	Float rides too high causing frost-back on suction line	Replace needle valve and seat
5. Worn pivot	Float rides too low, thus collecting oil and causing evaporator to become oil bound	Replace worn parts or entire float assembly
6. Float not level	Liquid level in float chamber will be changed causing either frost-back on suction line or oil logging — If float is tipped to side float arm may bind at pivot	Use spirit level to adjust hanger straps supporting float chamber.
7. Sticking float	Frost-back on suction line if stuck open, little or no refrigeration if stuck shut	Dress float pivot with a file or replace
8. Moisture in system	In SO ₂ systems, a corroded needle valve will result with same symptoms as in #4. If Methyl or Freon systems ice will form at needle valve plugging up the orifice and giving same symptoms as for #1	SO ₂ systems — clean system thoroughly and dehydrate — Methyl and Freon system — apply heat (a cloth dipped in hot water) to melt the ice, then install a dehydrator in liquid line.
9. Punctured float ball.	Float will sink, opening valve wide and causing liquid to flood thru evaporator and down suction line to compressor — Loud hissing noise at valve and cold suction line — no refrigeration — high suction pressure, low head pressure	Replace float ball
10. Undercharge of refrigerant	Float rides low keeping valve open — High pressure gas comes thru with liquid — loud hissing noise — suction pressure high — head pressure low — no refrigeration — suction line temperature normal	Locate and repair leak, then add the proper amount of refrigerant.

EXPANSION VALVES

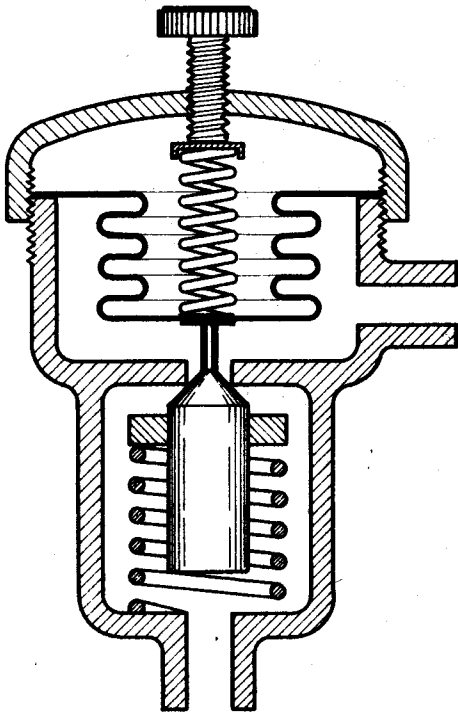

AUTOMATIC EXPANSION VALVE

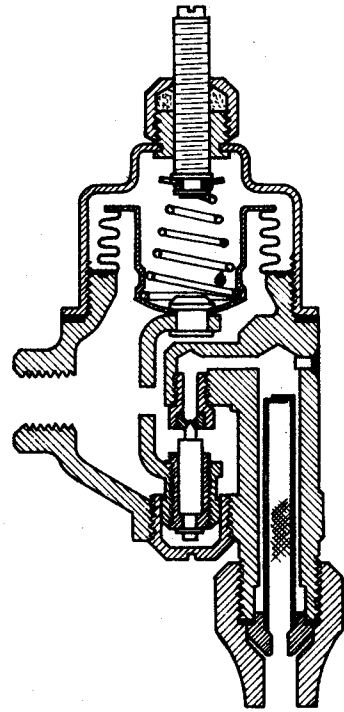

DETROIT LUBRICATOR
AUTOMATIC EXPANSION VALVE

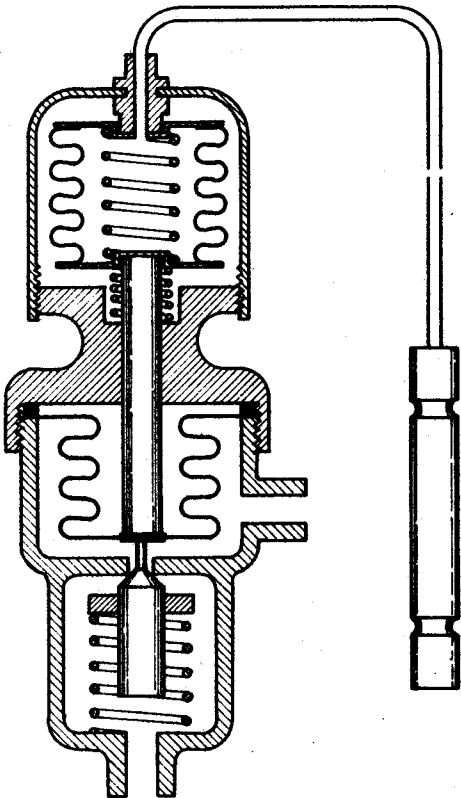

THERMOSTATIC EXPANSION VALVE

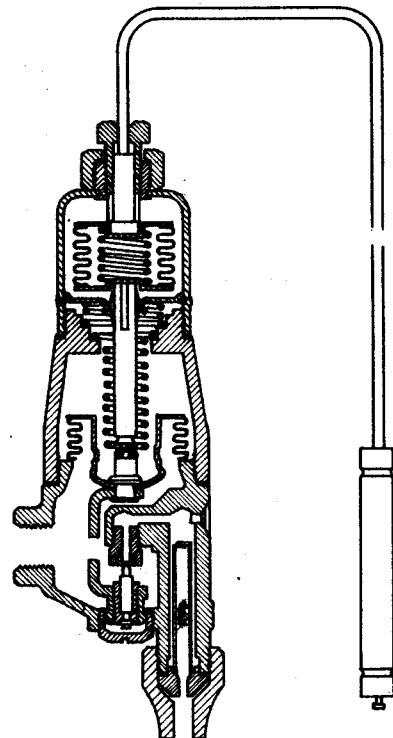

DETROIT LUBRICATOR
THERMOSTATIC EXPANSION VALVE

ELECTRIC SWITCHES

VOLATILE LIQUID THERMOSTAT
COLD CONTROL

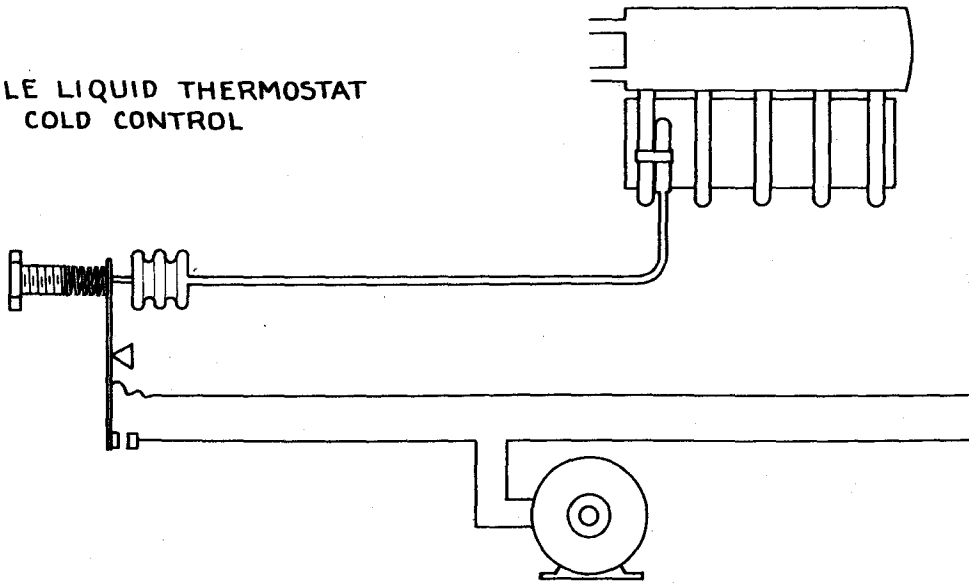

PRESSURE TYPE SWITCH
"PRESSURESTAT"

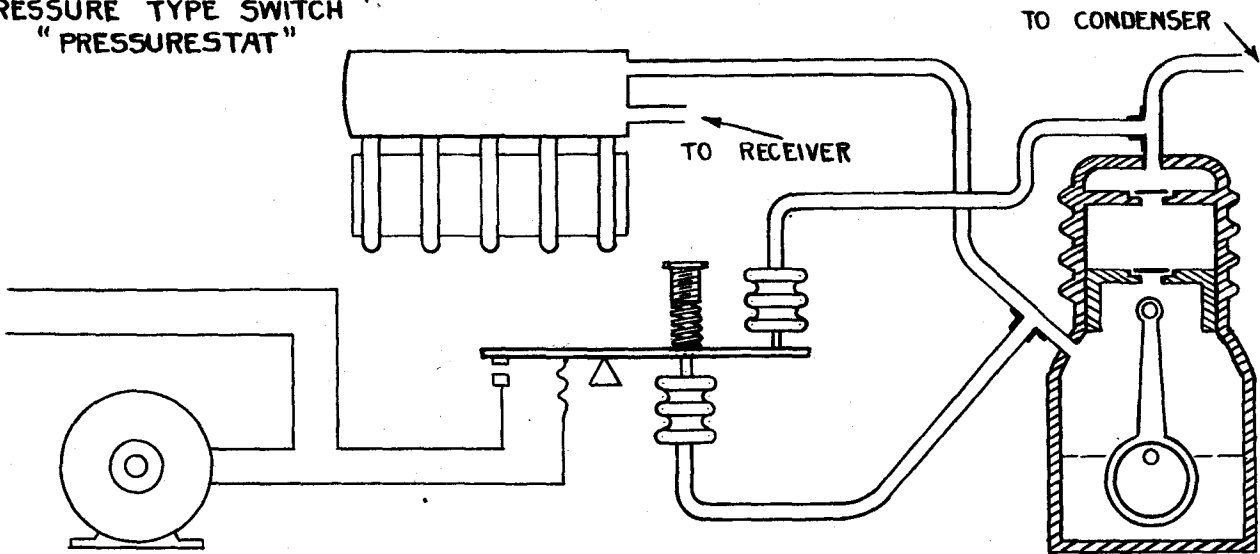

BI-METAL THERMOSTAT

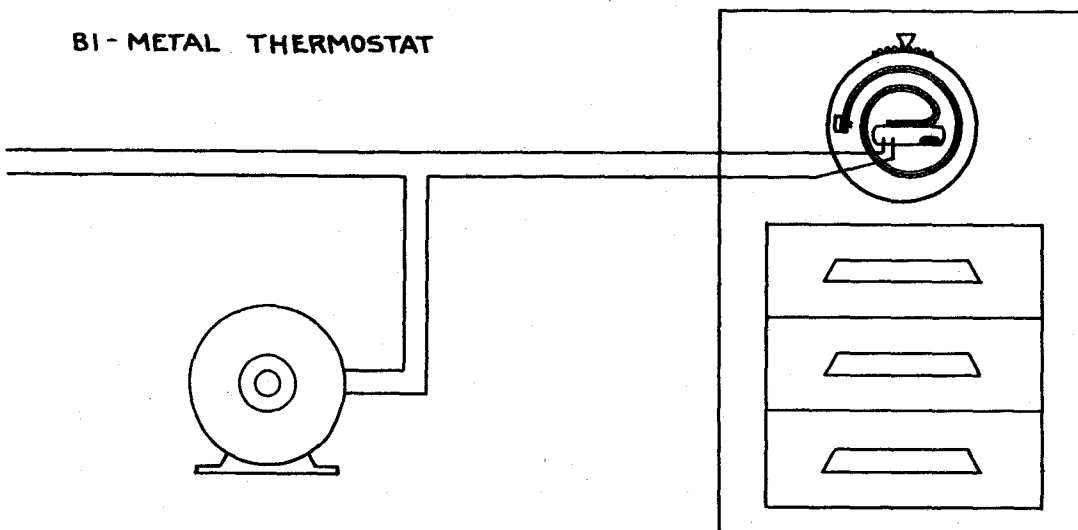

APPROXIMATE PRESSURE CONTROL SETTINGS

TYPE OF EVAPORATOR	APPLICATION	SULPHUR DIOXIDE		METHYL CHLORIDE		FREON-12	
		OFF	ON	OFF	ON	OFF	ON
Flooded-direct	Commercial or Domestic refrigerators	8"	6#	5#	17#	10#	25#
Flooded or dry-direct	Ice cube maker	14"	0#	0#	11#	4#	17#
Flooded-indirect	Ice cream cabinet	14"	6"	0#	6#	4#	12#
Flooded-indirect (Sweet water bath with ice accumulation on coils)	Beverage or water cooler	0#	6#	11#	19#	17#	27#
Dry-indirect (sweet water bath with ice accumulation on coil)	Beverage or water cooler	2"	6#	10#	19#	16#	27#
Dry-direct fin coil (non-frost)	Walk-in-cooler; Reachin-cooler; Show case	6"	10#	6#	24#	12#	33#
Forced draft unit coolers	Walk-in-cooler; Reachin-cooler;	0#	12#	12#	27#	18#	36#
Dry-direct fin coils	Ice-cream trucks and ice cream hardening rooms	16"	2"	3"	9#	2#	15#
Dry-indirect (Eutetic Brine Solution)	Ice-cream trucks	18"	14"	6"	0#	1#	4#
Dry direct fin coils	Air Conditioning (Comfort Cooling)	9#	21#	23#	40#	32#	52#

High Side Float Valves

Flooded System Using High Side Float Valve

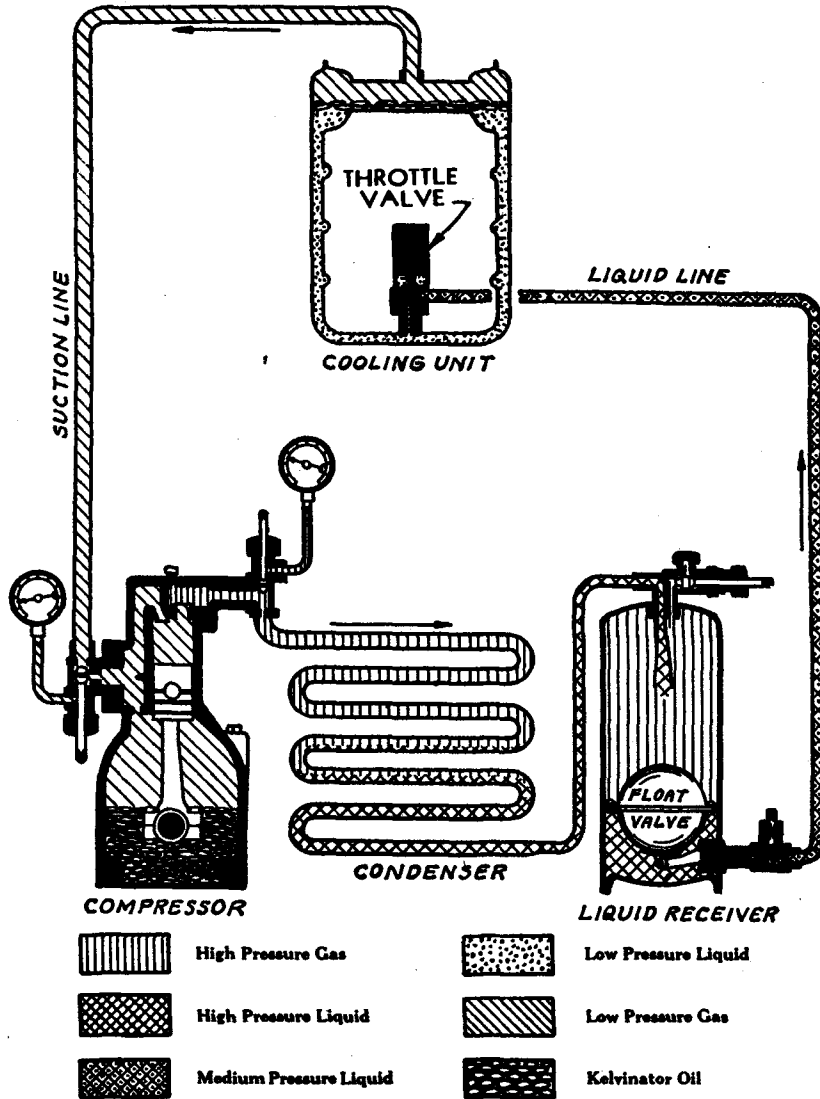

THROTTLING VALVE

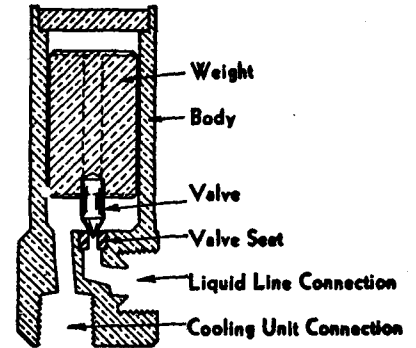

REPLACEMENT HIGH SIDE FLOAT

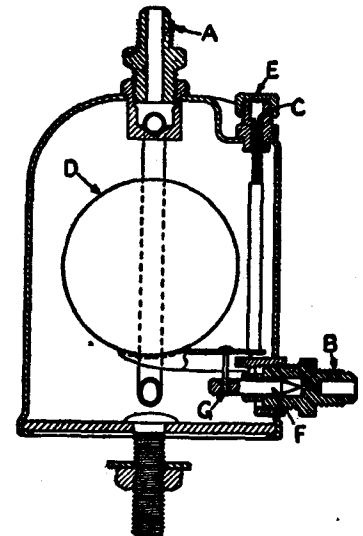

KEY TO LETTERS IN REPLACEMENT FLOAT DIAGRAM

- A. Liquid inlet from condenser or receiver
- B. Liquid outlet to evaporator
- C. Float lock screw
- D. Float ball
- E. Purge connection cap
- F. Needle valve
- G. Needle valve lever

TROUBLE CHART FOR HIGH SIDE FLOATS

<u>TROUBLE</u>	<u>SYMPTOM</u>	<u>REMEDY</u>
1. Overcharge of refrigerant	Frosted suction line -- suction pressure above normal -- head pressure above normal	Purge out a little refrigerant
2. Undercharge of refrigerant	Evaporator only partially frosted -- suction pressure low -- head pressure low	Locate and repair leak, add refrigerant
3. Leaky valve	Frosted suction line at beginning of running cycle	Replace needle valve and seat or entire float assembly
4. Float stuck closed	No refrigeration -- suction pressure very low, head pressure very high if no receiver tank is used. With receiver tank head pressure will be low	Replace float assembly
5. Float stuck open	Very little or no refrigeration suction line cold-base of compressor may be cold also. High suction pressure -- low head pressure	Replace float assembly
6. Punctured float ball	Same as #4	Same as #4
7. Air bound float	Little or no refrigeration. High head pressure -- low suction pressure	Purge air from float chamber
8. Throttle valve stuck closed (seldom occurs)	Same as #4	Replace throttle valve
9. Throttle valve stuck open	Frosted liquid line between float chamber and evaporator	Replace throttle valve
10. Moisture in system	May be same as either #8 or #9	Apply heat to throttle valve and install dehydrator in liquid line

REFRIGERATION CYCLE & DIAGRAM OF CONNECTIONS FOR COMMERCIAL APPLICATION

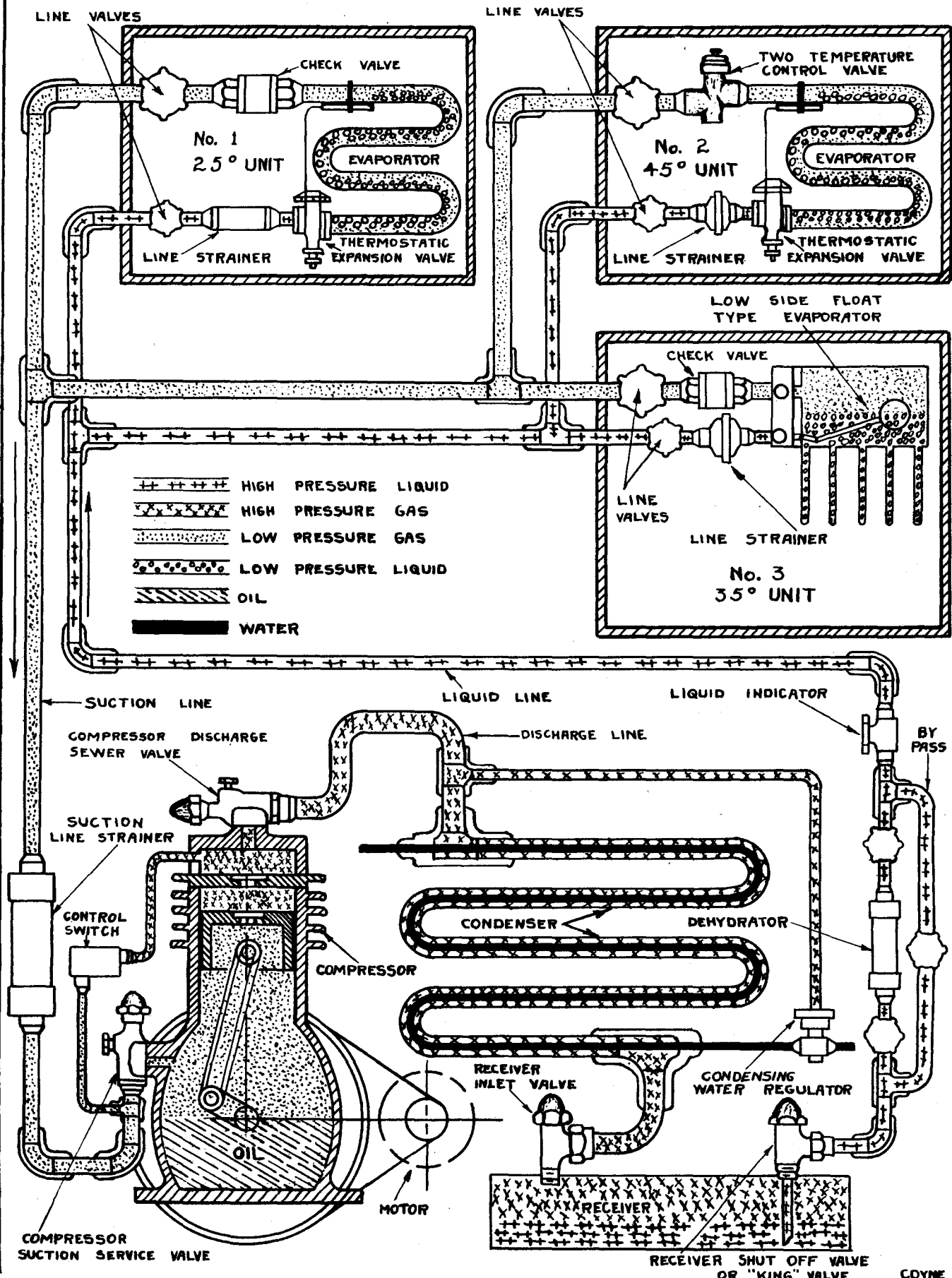

The Capillary Tube

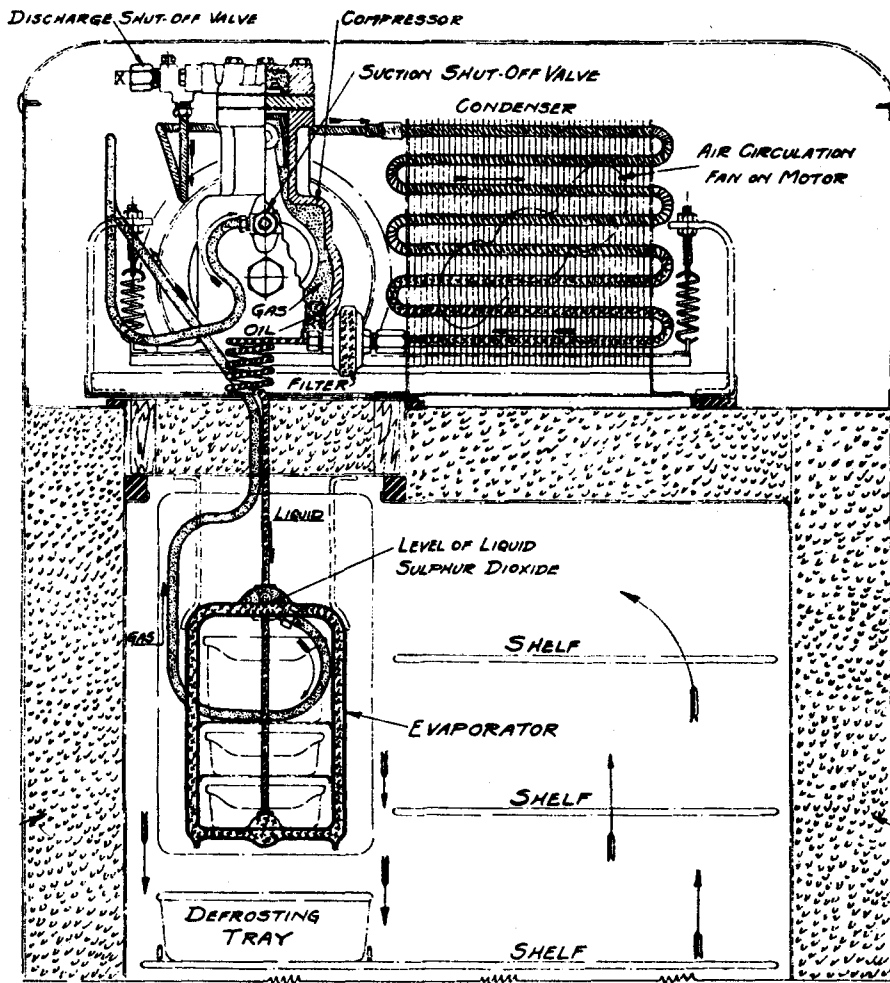

CAPILLARY TUBING



CAPILLARY TUBING FITTING



FRIGIDAIRE RESTRICTOR

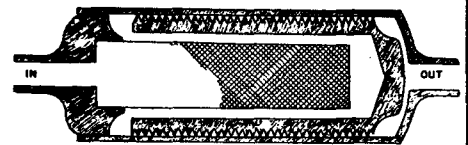

The capillary tube liquid control device is used with flooded type evaporators. In some few cases it is used with the continuous tube or dry type evaporators in which case an accumulator must be used at the outlet end of the evaporator to trap and evaporate any liquid which may be slopped thru the evaporator and thus prevent it from frosting the suction line.

The capillary tube consists of a length of tubing of very small inside diameter tubing (about $1/64$ "). This tube is designed to feed the necessary amount of refrigerant to the evaporator and also to produce the correct pressure drop from the high to the low side. The longer the tube and the smaller the diameter, the more restriction is offered to the flow of liquid. A good filter is always located ahead of this tube to prevent it from becoming clogged. The Frigidaire restrictor consists of a threaded plug inside a brass-shell so arranged that the liquid has to follow the path of the thread. This provides exactly the same action as a capillary tube.

TROUBLE CHART FOR CAPILLARY TUBE SYSTEMS

<u>TROUBLE</u>	<u>SYMPTOM</u>	<u>REMEDY</u>
Undercharge of refrigerant	Evaporator only partially frosted--head pressure low--suction pressure low. Unit probably will run continuously.	Located and repair leak--Add refrigerant
Overcharge of refrigerant	Poor refrigeration--high head pressure--high suction pressure--suction line frosted--long running time	Purge out a little refrigerant
Plugged Capillary Tube	No refrigeration--head pressure very high if no receiver tank is used--head pressure below normal if unit has receiver tank. Unit runs continuously unless head pressure is very high when overload relay will kick out	Remove capillary tube and blow out from outlet end--A stubborn tube may sometimes be cleared by straightening tube and inserting a fine wire. If these methods fail, replace tube. Clean or replace filter
Air in system	High head pressure--Refrigeration normal unless head pressure is very high--suction pressure normal unless head pressure is very high--long running time	Purge air thru D S V

3/4 TON FREON ROOM COOLING UNIT

AIRTEMP - MADE BY CHRYSLER

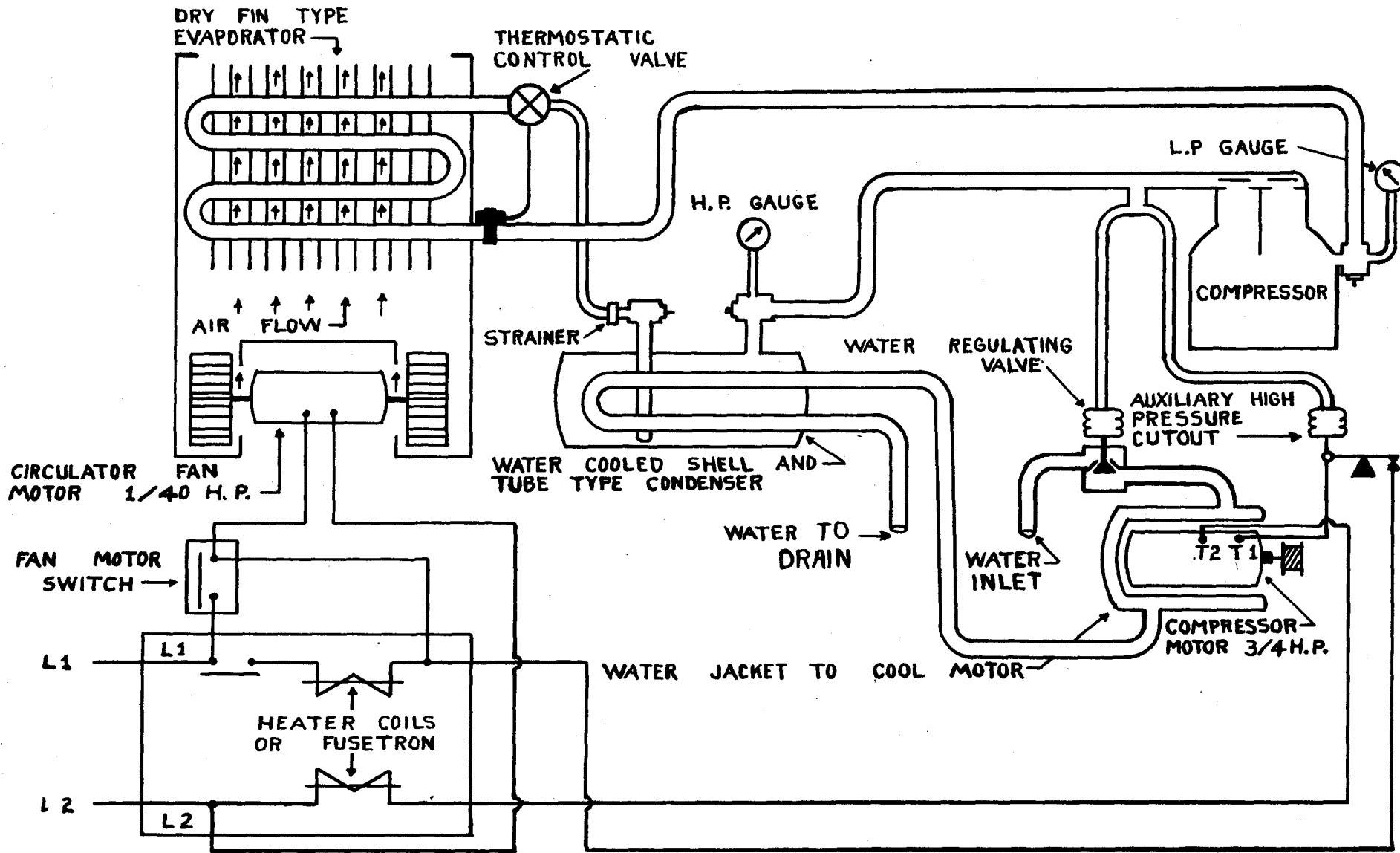

COMPLETE AIR CONDITIONING SYSTEM

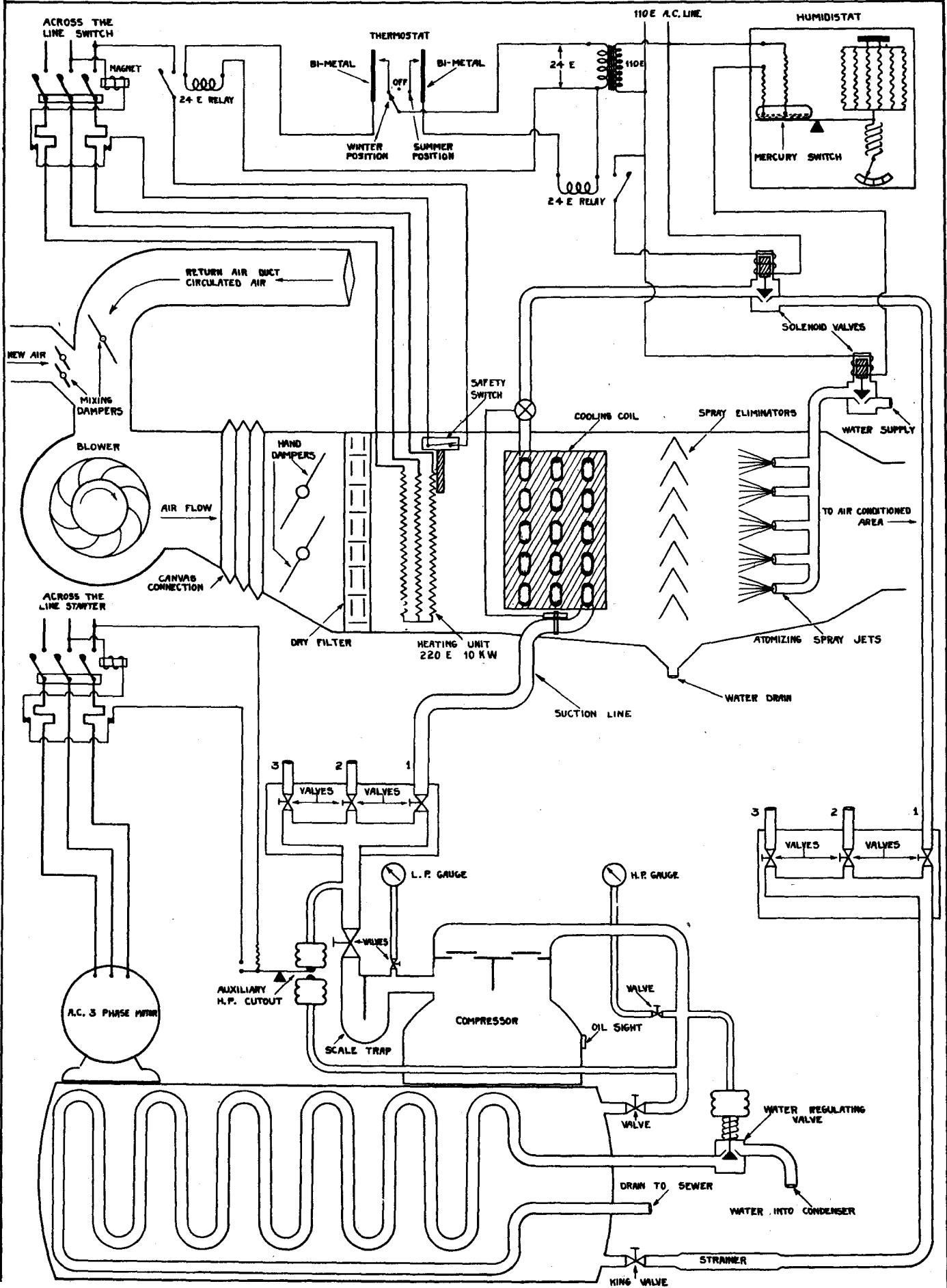

Flow Diagram of Decalorator American Blower Corporation

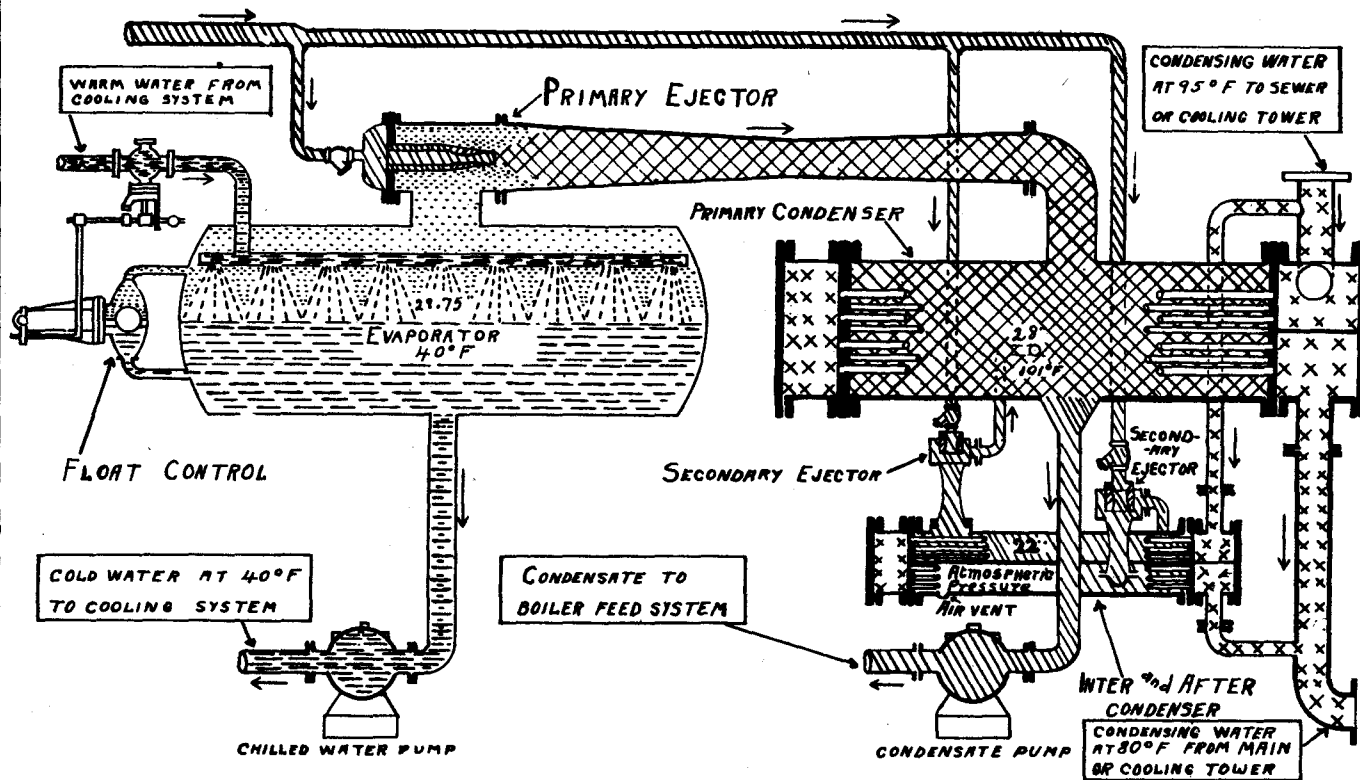

Chilled or decolorized water is produced in a Decalorator by the practical application of a well-known physical law. Water under high vacuum will vaporize at low temperatures. To produce evaporation, the sensible heat of the liquid is given up in the form of latent heat in the vapor. Chilling of the liquid is consequent to this conversion of heat.

In a Decalorator water is chilled by the maintenance of a high vacuum in a vessel into which the water is sprayed. Condensers of the power plant type operating in conjunction with highly efficient steam ejectors produce the vacuum.

A vacuum of 29.75" mercury (referred to 30" Barometer) is maintained in the Evaporator (Flash Chamber). The water to be cooled is introduced into the Evaporator in the form of a fine spray. Thus, sufficient water surface is present to cause a practically instantaneous evaporation of a small quantity of the water. This instantaneous evaporation is termed "flashing".

In this particular example, only about 1% of the water is "flashed" into vapor, absorbing its heat of vaporization from the remaining 99%, thereby chilling the main body of water to the required temperature of 40 degrees Fahrenheit. The decolorized, or chilled water is then pumped from the Evaporator by means of the chilled water pump and distributed to the points of use.

Referring to the Flow Diagram, it will be seen that a steam jet and Venturi tube (Primary Ejector) connect the Primary Condenser and the Evaporator. To condense the "flashed" vapor evolved in the Evaporator and the steam introduced through the Primary Ejector with water at ordinary temperatures, it is necessary to compress the vapor and entrained air from 29.75" to 28" mercury column. This compression is accomplished by the Primary Ejector steam. The steam and "flashed" vapor are condensed in the Primary Condenser. The condensate is removed by the condensate pump and returned to the Boiler Feed System. The water which has been vaporized in the Evaporator is replaced thru the valve operated by the Float Control.

The air present in the Primary Condenser after condensation of the steam and "flashed" vapor is eliminated from the system in the secondary condenser group. By means of the first of the secondary ejectors, the air is compressed from 28" to 22" mercury column and from 22" to atmospheric pressure by the other secondary ejector. The propelling steam introduced through the two secondary ejectors is condensed in the inter-and-after-condensers.

Steam at any pressure may be used in the operation of Decalorators. Although steam consumption decreases with increased steam pressure, it is economical to operate at low pressures when a supply of low pressure heating steam (14 lbs. gauge) is readily and cheaply available.

The items of equipment composing a Decalorator are of standard design and are in common usage. They have been used in similar service under similar conditions for many years. Their combined application in the Decalorator is in no way a departure from accepted practice.

DIAGRAM OF THE MILLS MODELS 26 & 30 ICE CREAM FREEZER.

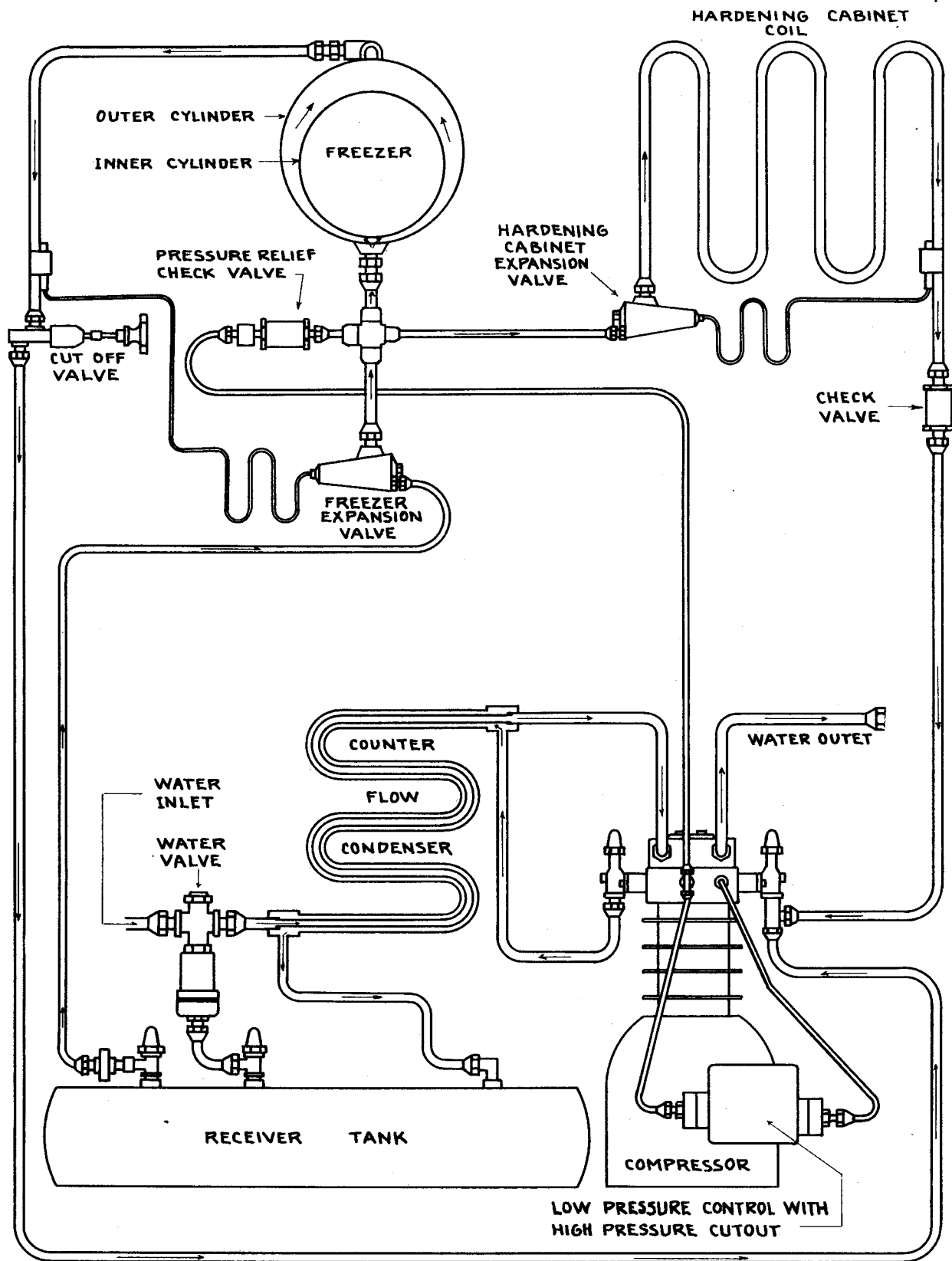

PRESSURE SWITCH SETTINGS FOR NON-FROST FIN COILS

AIR TEMPERATURE REQUIRED	SULPHUR DIOXIDE		METHYL CHLORIDE		FREON-12	
	OFF	ON	OFF	ON	OFF	ON
35° F.	6" vac.	9 lbs.	7 lbs.	23½ lbs.	13 lbs.	32 lbs.
38° F.	4" vac.	10 lbs.	9 lbs.	25 lbs.	15 lbs.	33 lbs.
40° F.	3" vac.	10 lbs.	10 lbs.	25 lbs.	16 lbs.	33 lbs.
42° F.	1" vac.	11 lbs.	11 lbs.	26 lbs.	17 lbs.	34 lbs.
45° F.	0 lbs.	11 lbs.	12 lbs.	27 lbs.	19 lbs.	35 lbs.
50° F.	3 lbs.	14 lbs.	15 lbs.	31 lbs.	23 lbs.	40 lbs.

PRESSURE SWITCH SETTINGS FOR BLOWER COILS

AIR TEMPERATURE REQUIRED	SULPHUR DIOXIDE		METHYL CHLORIDE		FREON-12	
	OFF	ON	OFF	ON	OFF	ON
35° F.	0 lbs.	9 lbs.	11 lbs.	23 lbs.	17 lbs.	31 lbs.
38° F.	½ lbs.	10 lbs.	12 lbs.	24 lbs.	19 lbs.	32 lbs.
40° F.	2 lbs.	10 lbs.	14 lbs.	25 lbs.	21 lbs.	33 lbs.
42° F.	3 lbs.	11 lbs.	15 lbs.	26 lbs.	22 lbs.	35 lbs.
45° F.	4 lbs.	13 lbs.	17 lbs.	29 lbs.	24 lbs.	38 lbs.
50° F.	6 lbs.	16 lbs.	20 lbs.	33 lbs.	28 lbs.	43 lbs.

THERMOSTATIC CONTROL SETTINGS

APPLICATION	CUT-OUT	CUT-IN
Flooded or dry indirect evaporators (Brine tanks)		
Bulb attached to side of tank	17° F.	29° F.
Bulb attached to suction line outlet	16	27
Bulb immersed in brine, not touching evaporator	17	25
Bulb immersed in brine, touching evaporator	11	26
Flooded-direct (copper evaporator)		
Bulb on frosted tube	14	28
Dry-direct (copper evaporator)		
Bulb on in	20	40
Bulb on ice tray sleeve	20	28
Bulb on last turn of coil	15	28
Flooded-direct (porcelain evaporator)		
Bulb on side	15	28
Bulb on header	15	30
Dry-direct (porcelain evaporator)		
Bulb on side	15	28
Stainless steel evaporators		
Bulb on side	7	23

mp. eg. hr.	Sulphur Dioxide SO ₂	Methyl Chloride CH ₃ Cl	Freon-12 CCl ₂ F ₂	F-114 (Frigidaire) C ₂ ClF ₄	Carrene CH ₂ Cl ₂	Herveen (Substitute for F-114)
20	17.9"	6.1"	.5 lbs.	22.9"	-----	-----
15	16.1"	2.3"	2.4 lbs.	21.8"	-----	-----
10	13.9"	.2 lbs.	4.5 lbs.	20.6"	28.1"	-----
5	11.5"	2.0 lbs.	6.8 lbs.	19.3"	27.8"	11.0"
0	8.8"	3.8 lbs.	9.2 lbs.	17.8"	27.5"	8.0"
5	5.8"	6.2 lbs.	11.9 lbs.	16.1"	27.1"	5.5"
0	2.6"	8.6 lbs.	14.7 lbs.	14.3"	26.7"	0 lbs.
5	.5 lbs.	11.2 lbs.	17.7 lbs.	12.1"	26.2"	2 lbs.
10	2.4 lbs.	13.6 lbs.	21.1 lbs.	10.1"	25.6"	4 lbs.
15	4.6 lbs.	17.2 lbs.	24.6 lbs.	7.7"	24.9"	6 lbs.
20	7.0 lbs.	20.3 lbs.	28.5 lbs.	5.0"	24.3"	8 lbs.
25	9.6 lbs.	24.0 lbs.	32.6 lbs.	2.1"	23.5"	10 lbs.
30	12.4 lbs.	28.1 lbs.	37.0 lbs.	0.5 lbs.	22.6"	12 lbs.
35	15.5 lbs.	32.2 lbs.	41.7 lbs.	2.1 lbs.	21.7"	14 lbs.
40	18.8 lbs.	36.3 lbs.	46.7 lbs.	3.9 lbs.	20.7"	16 lbs.
45	22.4 lbs.	41.7 lbs.	52.0 lbs.	5.9 lbs.	19.5"	18 lbs.
50	26.2 lbs.	46.3 lbs.	57.7 lbs.	8.0 lbs.	18.2"	20 lbs.
55	30.4 lbs.	53.6 lbs.	63.7 lbs.	10.2 lbs.	16.7"	21.5 lbs.
60	34.9 lbs.	57.8 lbs.	70.1 lbs.	12.6 lbs.	15.1"	23 lbs.
65	39.8 lbs.	64.4 lbs.	76.9 lbs.	15.1 lbs.	13.4"	28 lbs.
70	45.0 lbs.	72.3 lbs.	84.1 lbs.	17.9 lbs.	11.5"	32 lbs.
75	50.9 lbs.	79.4 lbs.	91.7 lbs.	20.8 lbs.	8.4"	37 lbs.
80	56.5 lbs.	87.3 lbs.	99.6 lbs.	24.0 lbs.	7.3"	45 lbs.
85	62.9 lbs.	95.6 lbs.	108.1 lbs.	27.4 lbs.	5.0"	-----
90	69.8 lbs.	102.3 lbs.	116.9 lbs.	31.0 lbs.	2.4"	-----
95	77.1 lbs.	113.4 lbs.	126.2 lbs.	34.8 lbs.	0.19 lbs.	-----
100	85.1 lbs.	118.3 lbs.	136.0 lbs.	38.8 lbs.	1.6 lbs.	-----
105	93.5 lbs.	128.6 lbs.	146.5 lbs.	43.1 lbs.	3.1 lbs.	-----

STANDARD SERVICE VALVE.

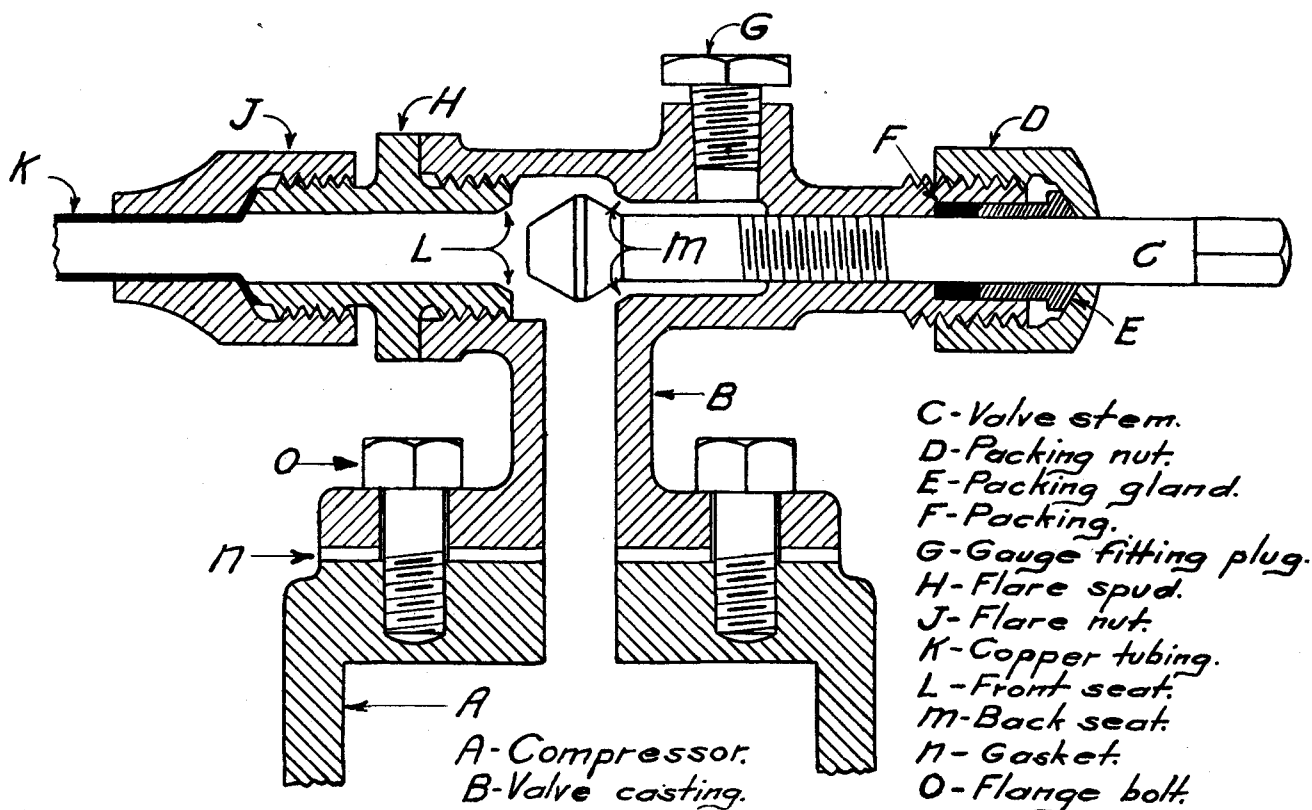

In order to simplify service operations such as adding or removing refrigerant, adding or removing oil, removing air (purging) or removing defective parts, most refrigeration systems are equipped with service valves. Service valves consist of the following:

1. Suction service valve (SSV)
2. Discharge service valve (DSV)
3. Receiver shut-off valve or king valve (KV)
4. Other shut-off valves in the system

In order to determine the pressure existing in the high and low sides of the system, gauges are installed in the service valve connections, the pressure gauge in the DSV and the compound gauge in the SSV.

When manipulating service valves, never front seat the DSV and operate the compressor unless the gauge fitting port is open, as this action may result in blowing a gasket and on large compressors may even blow the head off the compressor. If a gauge is installed in the DSV, the gauge will be ruined if the compressor is operated with the valve frontseated.

When manipulating service valves, do not turn the valve stem too tight. Merely turn it snugly to the seating position.

If the valve leaks at the packing, proceed as follows:

1. Stop the unit and back-seat the valve.
2. Remove the packing nut and gland.
3. Remove the old packing.
4. Repack the valve with graphite string or packing washers, then replace the gland and nut. Tighten the packing nut and if necessary add more packing.

When service valves are stuck or difficult to turn, loosen the packing gland as this will sometimes remedy the trouble. The packing glands on some valves require the use of special gland wrenches to loosen or tighten them.

Some units are not equipped with standard service valves, but the operation of the valve can usually be determined by observing the position and external construction of the valve casting. Two such examples of special service valves may be found on the Majestic and Crosley conventional units.

On the Majestic unit, the DSV and SSV are constructed differently. The gauge connection on both valves is on the end of the valve where the tubing connection is located on standard service valves. To shut off the gauge connection, the valve has to be front-seated and this is the normal running position. The SSV on the Majestic unit contains a check valve and when this valve is back-seated the suction line from the evaporator is shut off. The construction of the DSV is such that with the valve back-seated, the discharge port from the compressor is shut off. Therefore, it is imperative to NEVER UNDER ANY CIRCUMSTANCES OPERATE THE MAJESTIC COMPRESSOR WITH THE DSV BACK-SEATED. Since the gas is not able to escape thru the back-seated valve, it will continue to build up pressure in the compressor housing until the bellows in the shaft seal bursts.

In the Crosley conventional unit, the construction of both the DSV and SSV is the same. The gauge connections on the service valves are in the same position as they are on standard service valves, but the flanged connection to the compressor housing is on the end of the valve instead of on the side. The procedure for installing gauges on these valves is exactly the same as for standard service valves. It is, however, impossible to make a compressor efficiency test, since when the SSV is front-seated, both the gauge connection and the suction line connection are shut off from the compressor and the gauge will, therefore, not register the vacuum being drawn in the compressor housing. With this compressor UNDER NO CIRCUMSTANCES OPERATE THE COMPRESSOR WITH THE DSV FRONT-SEATED.

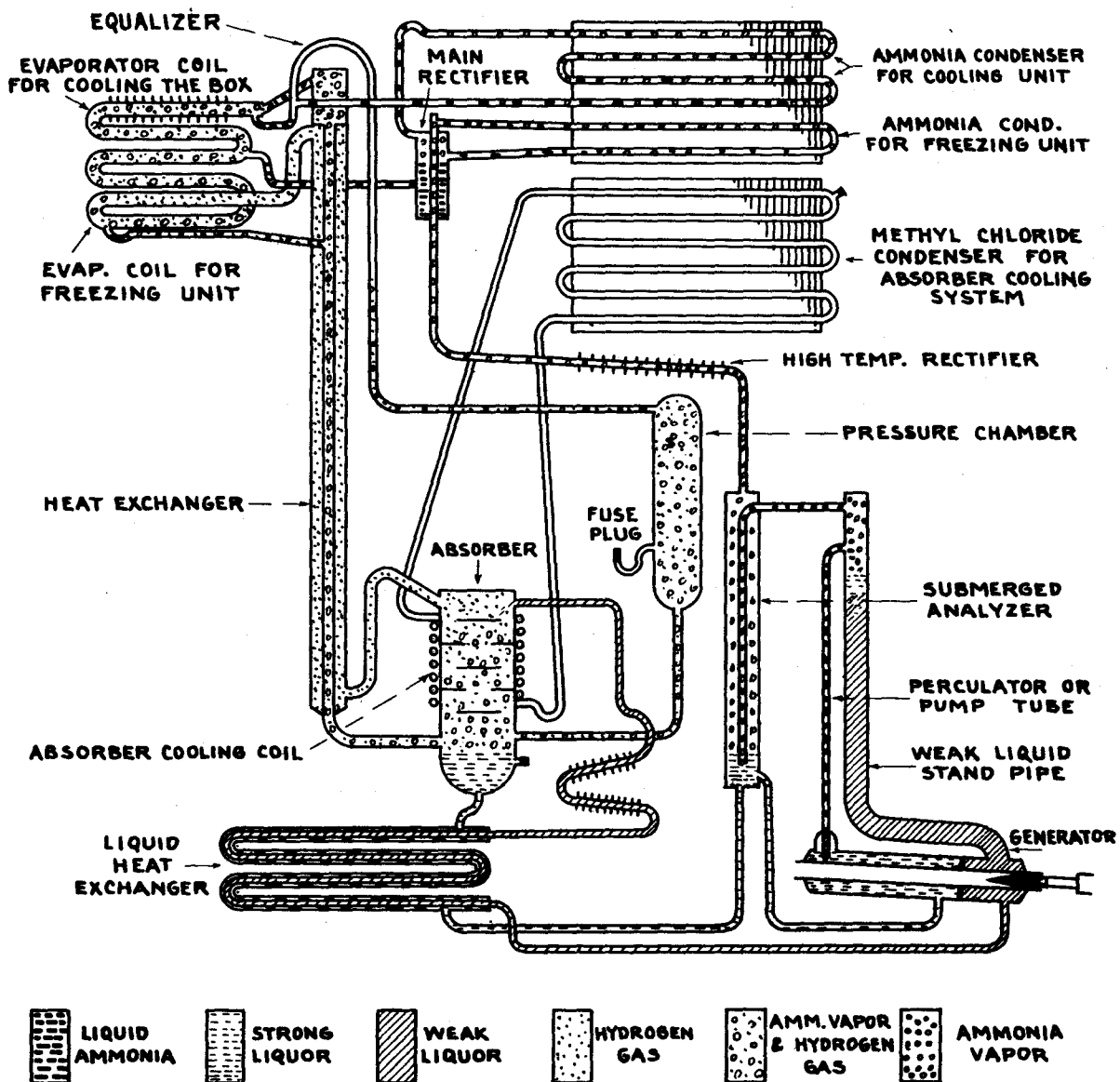

ELECTROLUX AIR-COOLED UNIT

The air-cooled Electrolux is practically the same as the water-cooled unit with the exception of the medium for cooling. This unit has two air-cooled condensers as shown. The lower one is charged with methyl chloride which is used to absorb the heat from the absorber and release it at the condenser where it is carried away by convection.

By using air-cooled condensers, there is no need of a water supply as in the water-cooled unit. Caution in moving should be exercised to prevent tipping beyond 45 degrees.

Careful study of the diagram, using the Code at the bottom, will explain the operation of the unit.

INSTALLATION OF GAUGES AND COMPRESSOR EFFICIENCY TESTS

The proper procedure for installing gauges is as follows:

1. Stop the unit.
2. Back-seat the service valve.
3. Remove the gauge fitting plug.
4. Insert a half-union (usually 1/8" IPT by 1/4" SAE flare thread)
5. Connect the gauge to the half-union with a short length of tubing. Leave the flare nut at the gauge loose.
6. Crack the service valve and hold open until a strong odor of gas is noticed at the loose connection. This is to purge the air out of the gauge tube.
7. Tighten the loose connection and start the unit.
8. Crack the valve away from its back-seat to get a gauge reading. If the gauge needle vibrates too much, turn the valve stem slowly to the left until a fairly steady reading is obtained.

The procedure for removing the gauge is as follows:

1. Stop the machine.
2. Back-seat the service valve.
3. Remove the gauge and half-union.
4. Insert the gauge fitting plug and check for leaks.

Compressors with Shut-off Valves

Some compressors are equipped with a discharge shut-off valve in the head instead of the regular discharge service valve. The gauge fitting port will be in the compressor head. To install a pressure gauge on this type of compressor, proceed as follows:

1. Stop the unit.
2. Install a compound gauge in the SSV first.
3. Front-seat the SSV. If there is no vacuum on the base of the compressor, start the unit and operate until the compound gauge shows a vacuum. This procedure is to prevent gas in the low side from surging up thru the compressor valves and out the gauge fitting port in the head when the plug is removed.
4. Close the discharge shut-off valve in the head.
5. Remove the gauge fitting plug and install the pressure gauge.
6. Be sure to open the shut-off valve again before starting the compressor. Otherwise the gauge may be ruined.

COMPRESSOR EFFICIENCY TESTS

Shaft Seal Leak Test

To test the shaft seal and other compressor parts for refrigerant leaks to the atmosphere, place hot water in the ice cube trays to build up about a 40 lb. pressure in the low side of the system. Then test for refrigerant leaks using 26% ammonia for sulphur dioxide systems and a halide torch for methyl chloride and freon systems.

Valve Test

1. Stop the unit.
2. Install a compound gauge in the SSV and a pressure gauge in the DSV. The high side pressure should be at least 40 lbs. before starting this test.
3. Front-seat the SSV and start the unit. The compound gauge should begin to show a vacuum that rapidly increases to at least 25 inches. If the compressor pulls a vacuum slowly at first, it may be due to the fact that gas is boiling up out of the oil which may be saturated with refrigerant. During this pump-down procedure, the compressor may slug oil. This will be indicated by a knocking noise in the compressor valves. If this noise becomes too violent, stop the compressor for a few minutes until the oil foam settles, then start up the unit again.
4. When the vacuum will finally increase no farther, stop the unit. Crack the SSV to build the crankcase pressure back up to zero lbs. Then front-seat the valve again.
5. Start the unit and time it to see how long it takes to pull a vacuum the second time. It should pull down to at least a 25" vacuum in less than 1/2 minute.
6. Stop the unit and allow it to remain idle for 5 minutes. The vacuum reading should remain steady during this off-period.

If during the above test, the compressor pulls the vacuum very slowly or will not pull a vacuum greater than 15 inches, the reed suction valve is usually leaking. If the compressor pulls a vacuum but will not hold it, the reed discharge valve is leaking.

Excessive clearance between the top of the piston and the bottom of the valve plate may also cause the compressor to be inefficient. This can be due to using a gasket material that is too thick or to worn wrist pins and bearings. When the piston is at top dead center, the clearance between the piston and valve plate should be from .007 to .010 of an inch.

Ring Test

1. Stop the unit and install a pressure gauge in the DSV.
2. Start the unit and allow it to operate for a few minutes so that the pistons, rings and valves will have a good film of oil on them.
3. Stop the unit and front-seat the DSV.
4. Start the unit. Caution---be sure to keep your hand on the switch. When the pressure gauge registers 125 lbs. pressure, stop the unit. If the rings are in good condition, this pressure will be attained rapidly (in a few revolutions). If the rings are leaking, the high pressure gas will blow back to the compressor base and the pressure will not attain 125 lbs. rapidly or perhaps not at all.
5. After the test, back-seat the DSV immediately to place the unit in normal operating condition.

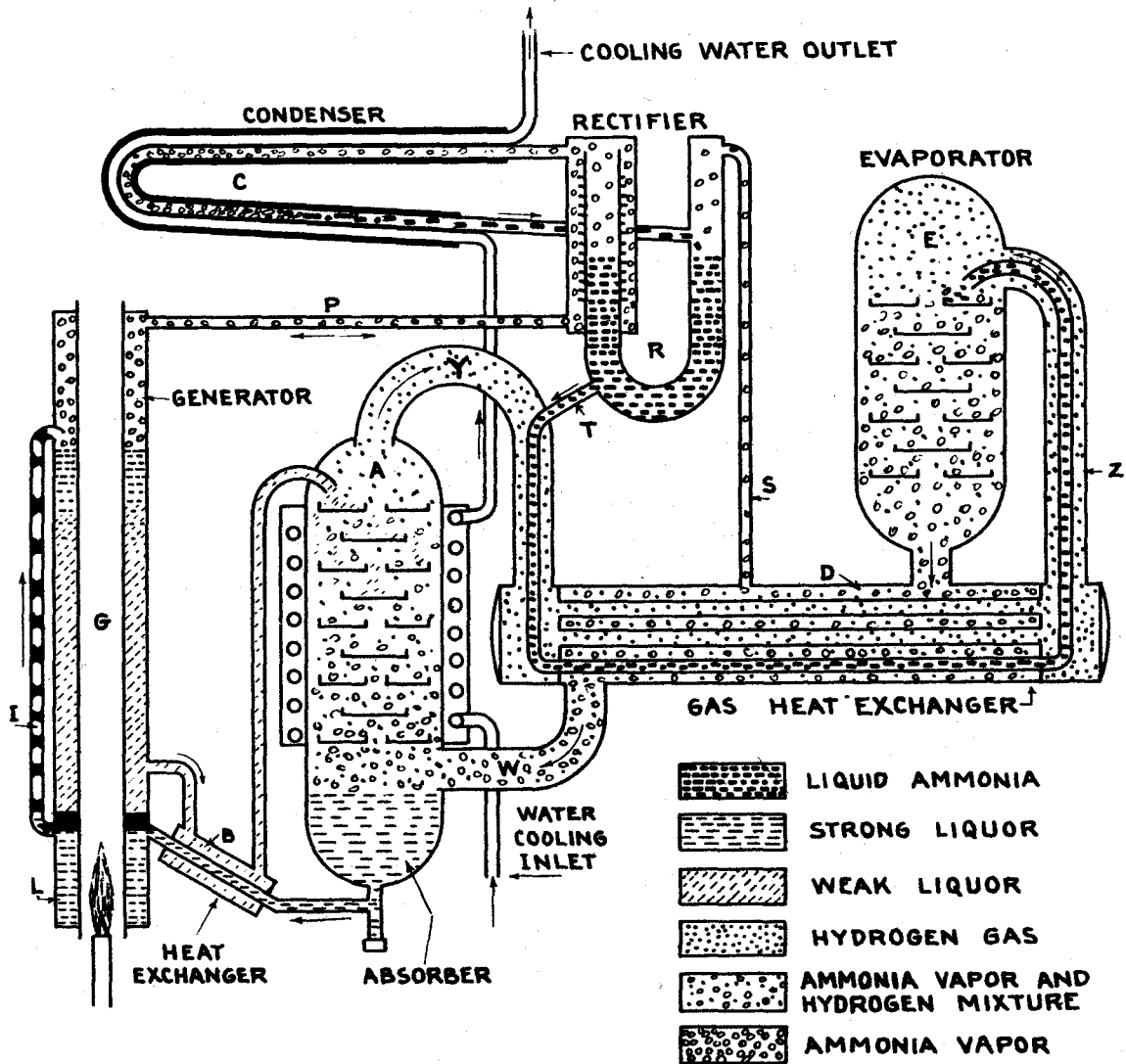

ABSORPTION TYPE REFRIGERATION UNIT - ELECTROLUX WATER-COOLED.

This unit has no moving parts and is operated by means of heat energy. The refrigerating effect is governed by the amount of heat applied to the generator. It is sealed under a pressure of 200 lbs. and in normal operation attains a pressure of about 225 lbs. per sq. in.

Water is used as a medium to carry away the heat, making it necessary to have water pressure in any home where this unit is to be used. In shipment or moving, it is important to keep the cabinet as level as possible. If tipped over 45 degrees, the chemicals are apt to mix and thus make it inoperative.

Careful study of the diagram, using the Code at the bottom, will explain the operation of the unit.

CHARGING AND DISCHARGING REFRIGERANT

General Procedure for Discharging a Refrigeration System

1. Stop the unit, and install a compound gauge in the SSV.
2. Back-seat the DSV, remove the gauge fitting plug and install a half union.
3. Connect one end of the charging line tightly to this half union and the other end loosely to the drum.
4. Purge the air from the line by cracking the DSV. When a strong odor of gas is evident at the loose connection, all of the air has been removed, then close the drum valve and tighten the connection.
5. Open the service drum valve.
6. Front-seat the DSV.
7. Place the chemical drum in a pail of cold water and start the unit. On flooded systems place hot water in the ice cube trays.
8. When the compound gauge shows a good vacuum and there is no frost on the evaporator or receiver, the unit is discharged.
9. Stop the unit, close the service drum valve and remove the charging line.
10. Place a gauge fitting plug or a pressure gauge in the DSV and back-seat the valve.

Pumping Out Air

Before charging a completely discharged unit, care must be taken to see that all air is removed. The procedure for removing the air is as follows:

1. With the unit idle, front-seat the DSV.
2. Remove the gauge fitting plug from the DSV.
3. Install a compound gauge in the SSV.
4. Start the unit and allow it to operate until a good vacuum is obtained (25 to 28 inches), then stop the unit. The air will be pumped out thru the gauge fitting port in the DSV and into the atmosphere. Hold a rag over the open DSV fitting during this operation to prevent any oil that is slugged thru the discharge valve from being pumped onto the walls or floor.
5. Insert a gauge fitting plug or pressure gauge in the DSV and back-seat the valve.

General Procedure for Charging by the Gaseous Method (Low Side Charging)

1. Stop the unit.
2. Install a pressure gauge in the DSV.
3. Back-seat the SSV and install a tee fitting (1/4" SAE flare one end 1/8" IPT).
4. Install a compound gauge on tee.
5. Connect the charging line between remaining branch of tee and drum.

CHARGING AND DISCHARGING REFRIGERANT (Continued)

6. Loosen flare nut at gauge and purge air out of line by cracking the drum valve. Then close drum valve and tighten flare nut.
7. Front-seat the SSV and start the unit.
8. Open the drum valve slowly to keep the pressure down to about 5 or 10 lbs. above normal low side pressure.
9. When the drum begins to get cold and the pressure drops, place the drum in a pail of warm water.

Place or hang drum on a scale so the proper amount of refrigerant by weight may be added. When adding refrigerant to an undercharged unit, place SSV in neutral position then open and close the drum valve intermittently and observe the operating pressures and the evaporator frost line during the time the drum valve is closed. When the operating pressures are normal and the evaporator is completely frosted, the unit is fully charged. Then add from 1/4 to 1/2 lb. to give the system a little reserve (except on high side float and capillary tube systems).

Detailed Procedure for Charging Various Types of SystemsHigh Side Float Systems

The amount of refrigerant charge is very critical in this type system. When charging a completely discharged system, front-seat the SSV and charge the refrigerant in at a pressure slightly above normal low side pressure. Charge in the proper amount of chemical by weight plus about 2 oz. to compensate for gas losses in purging. When adding refrigerant to an undercharged system, connect the drum, purge the charging line, and place the SSV in the neutral position. Then start the unit and open and close the drum valve at intervals of one or two minutes depending upon the head pressure. If head pressure increases more than 10 or 15 lbs. above normal, close drum valve until it settles down again. Continue this procedure until the suction line frosts out from the evaporator a few inches. Operate the unit for 10 or 15 minutes to allow any oil that has accumulated in the evaporator to return to the compressor. If the frost disappears from the suction line, add a little more refrigerant. When properly charged the suction line should frost 3 or 4 inches out from the evaporator.

During the above charging procedure, maintain a pressure in the refrigerant drum about 20 lbs. higher than the low side pressure in the unit. This can be accomplished by placing the drum in a pail of warm water.

Any condition indicating air in the system should be corrected by purging thru the purge valve on the float chamber. On floats lacking such a purge valve, air may be purged thru the DSV on the compressor. Quite a bit of refrigerant gas will be lost when purging at the DSV; therefore, enough refrigerant should be added to compensate for this loss.

Capillary Tube Systems

The amount of refrigerant charge in a capillary tube system is equally as critical as it is in high side float systems. The operating characteristics of these two systems are very similar, therefore, the procedure for charging is the

CHARGING AND DISCHARGING REFRIGERANT (Continued)

Low Side Float Systems

When charging a low side float system, use the general method of charging thru the low side by front-seating the SSV and drawing in the proper amount by weight.

When adding refrigerant to an undercharged system, add refrigerant intermittently until the loud hissing noise in the evaporator has ceased and it is frosting properly. Then add from 1/4 to 1/2 lbs. to give the system a reserve of liquid in the receiver tank. The charge in this type system is not so critical. Any excess refrigerant will be stored in the receiver tank.

Expansion Valve Systems

Use the same general procedure for these systems as for low side float systems. When adding refrigerant to an undercharged unit, charge intermittently until the entire evaporator is frosted. Then add from 1/4 to 1/2 lbs. to give the unit a reserve of liquid in the receiver.

After any charging procedure observe the operating pressures during a running cycle to see that they are approximately correct.

Charging by the Liquid Method
(High Side Charging)

This method of charging is usually used for charging commercial systems and for some hermetically sealed domestic units. Care must be taken to see that the refrigerant drum is absolutely clean and contains no sediment or foreign material as this would be carried into the system with the liquid.

The machine should remain idle during the charging procedure. When charging a completely discharged unit, all air should be evacuated from the unit. This may be done by operating the unit with the DSV front-seated and blowing the air out through the open gauge fitting port in the DSV. On hermetically sealed units, it is usually necessary to use an auxilliary compressor to draw out the air. Before charging an under-charged unit, it should be stopped and allowed to remain idle until the head pressure has dropped to the maximum saturated vapor pressure of the refrigerant.

With the machine still idle, the procedure for charging is as follows:

1. Place the refrigerant drum in hot water at 125° F. for a few minutes until the drum pressure is from 10 to 25 lbs. higher than the head pressure of the unit to be charged.
2. Connect a short charging line to the drum.
3. Back-seat the DSV and install a half union.
4. Connect the drum to the DSV, purge the connection and tighten.
5. Place the DSV in the neutral position.

CHARGING AND DISCHARGING REFRIGERANT (Continued)

6. Invert the drum and open the drum valve (Do not open the drum valve before the drum is inverted). Then the weight of the liquid plus the vapor pressure above it will force the liquid refrigerant out of the drum, through the condenser and into the receiver. When the liquid is flowing out of the drum, a hissing noise will be heard, When this subsides the drum is empty or the pressures have become equalized. In this case apply heat by again placing the drum in hot water.
7. When the system is fully charged, close the drum valve first to allow the liquid to drain out of the charging line into the system. Then back-seat the DSV and remove the drum and charging line.

When charging a completely discharged unit, charge in the proper amount by weight. When charging an under-charged unit, add a few pounds, then close the drum valve and place the service valves in normal operating position. Operate the unit for a few minutes to observe the operating pressures and the frost-line on the evaporator. When these are normal, the unit is fully charged. Most commercial units have sufficient receiver capacity to hold a few pounds of reserve refrigerant; in which case, an amount equal to about 10% of the regular charge may be added to compensate for gas losses in purging the minor service operations.

Transferring Refrigerants from One Drum to Another

Refrigerant may be transferred in the liquid form from a large supply drum to smaller drums by the following procedure:

1. Place the supply drum in hot water (not to exceed 125° F.) to raise its pressure.
2. Place the small drum in a pail of cold water (preferably ice water). Set the pail with its contents on a scale and record its weight.
3. Invert the supply drum, raising it above the small drum, and connect the two together with a flexible charging line looped in such a manner as not to interfere with the weight recorded on the scale.
4. Open both drum valves and allow the desired amount of chemical to enter the small drum (Not to exceed its rated capacity).
5. Close supply drum valve first and allow the tube to drain out into the small drum before closing its valve.

Cleaning Service Drums

The service man should carry two drums for every refrigerant he uses, one to be used as a supply drum and the other as a service drum. To keep the supply drum clean and free from oil it should never be used to discharge a unit. In many cases, when a refrigeration system has been in use for a time, it will contain sludge and deposits of foreign material. The service drum should be used to discharge a dirty system. Dirty refrigerant may be reclaimed by pumping it out of the service drum in vapor form through a chemical dehydrator charged with silica gel or calcium oxide.

CHEMICAL CHART

Chemical Or Trade Name	Chemical Formula	Boiling Point At Atmospheric Pressure	A.E.V. Settings For Domestic Units	High Side Pressure For Air Cooled Units At 70°F Room Temperature	Latent Heat of Vaporization In B.T.U.'s Per Lb. At 5°	Inflammable Or Safe	Offensive Odor	Method Of Testing For Leaks	Dehydration Method
1. Sulphur Dioxide	SO ₂	14°	6"	65*	169	Safe	Yes	26% Ammonia Swab	Heat
2. Methyl Chloride	CH ₃ Cl	-11°	6"	85*	178	Inflam.	No	Halide Torch	Chemical
3. Freon or F ₁₂	CCl ₂ F ₂	-22°	14"	105*	69	Safe	No	" "	"
4. Ammonia	NH ₃	28°	20"	175*	565	Inflammable Explosive	Yes	Sulphur Taper	Heat
5. Isobutane	C ₄ H ₁₀	10°	3"	60*	159	Inflam.	No	Liquid Soap	Chemical
6. Ethyl Chloride	C ₂ H ₅ Cl	54°	20"	30*	177	Inflam.	No	Halide Torch	"
7. Carrene	CH ₂ Cl ₂	105°	28"	8"	149	Safe	No	" "	"
8. Methyl Formate	C ₂ H ₄ O ₂	86°	26"	11*	231	Safe	No	Liquid Soap	Heat
9. Carbon Dioxide	CO ₂	-108°	300"	900*	115	Safe	No	" "	Chemical
10. Freon-11	CCl ₃ F	75°	24"	5*	93			Halide Torch	Chemical

HIGH SIDE PRESSURES.

Temp. of Air in Degrees F.	SO ₂ L.S.P.=6"Vac.	CH ₃ Cl L.S.P.=5"	Freon-F ₁₂ L.S.P.=15"
40°	38*	54*	75*
50°	46*	64*	85*
60°	55*	74*	97*
70°	68*	86*	110*
80°	81*	102*	128*
90°	95*	117*	145*
100°	100*	135*	156*
110°	125*	152*	190*

On water-cooled condensers the water regulating valve should be set to maintain approximately a 20° temperature differential between the inlet and the outlet water. Barring abnormal low-side pressures, this will maintain normal head pressures.

Normal head pressures will vary between the values given in the chart for air cooled condensers for 70° and 80° temperatures.

CHARGING AND DISCHARGING REFRIGERANT (Continued)

A dirty cylinder may be cleaned by first evacuating it, then removing the valve and flushing it out with carbon-tetra-chloride or some other solvent. To thoroughly dry it out, it should be baked in a bake oven for four to five hours at 240° F. while drawing a vacuum on it at the same time. If the drum contains a fusible plug, this should be removed during the baking process.

Safety Rules

1. Handle refrigerant drums carefully. Do not drop them or tip them over.
2. Never allow a refrigerant drum to be exposed continuously to the sun.
3. When applying heat to a service drum, submerging it in hot water (not to exceed 125° F.) is preferable. Never under any circumstances apply a torch to any refrigerant container unless a pressure gauge is installed where it will register the pressure created by the heat. Safe pressures will vary according to the refrigerant as follows:

(a)	Maximum safe pressure for	SO ₂	135 lbs.
(b)	" " " "	CH ₃ Cl	175 lbs.
(c)	" " " "	CCl ₂ F ₂	190 lbs.
4. Never exceed the maximum rated capacity when filling a refrigerant cylinder.
5. Be careful when opening up any part of a refrigeration system (especially low side float evaporators). Even though the system has been discharged, vapor may still be boiling up out of the oil and may create enough pressure to blow refrigerant saturated oil into your face. Wear goggles.
6. Never try to stop a liquid refrigerant leak with your hand or fingers. The rapidly expanding liquid will absorb heat from your hand or any part of your body that it comes in contact with. A bad case of frost-bite may result.
7. Do not open the service drum valve more than 4 or 5 turns as it may screw clear out and cause a bad accident besides losing all the refrigerant in the drum.

BALANCING THE PRESSURE TO REMOVE DEFECTIVE PARTS

On the majority of conventional type refrigerators, the entire refrigerant charge can be pumped into the liquid receiver. When this is possible, the following parts can be removed without discharging the system:

1. Liquid line
2. Liquid control valve (except a high side float or a capillary tube)
3. Strainers in the liquid line
4. Dehydrators in the liquid line
5. Evaporator
6. Suction line
7. Compressor

The procedure is as follows:

1. Close the king valve and start the unit.
2. Run the compressor until the evaporator is entirely defrosted and about 2 25" vacuum is obtained on the compound gauge.
3. Crack the king valve and bring the low side pressure back up to zero or one lb. pressure.
4. Close the king valve again and front-seat the DSV.

The pressure is now balanced from the DSV back thru the low side of the system to the king valve and any part between these two points may be removed.

Purging Air from a Unit

An indication of air in the system is given by high head pressure and the failure of this pressure to drop back several pounds when the unit stops.

The air will be trapped in the condenser and receiver tank. Some units have a purge valve on the receiver tank. On this type unit the procedure for purging is as follows:

1. Stop the unit and allow it to remain idle for about two minutes.
2. Crack the purge valve and allow air and gas to slowly escape until the bottom of the receiver tank begins to get cool. Then close the purge valve.
3. Start the unit and operate for a few minutes. If the presence of air is still indicated, repeat the purging procedure.

On units which contain no purge valve, remove the gauge fitting plug or gauge from the DSV and purge system by cracking the DSV.

Some refrigerant will be lost during the purging procedure. After purging, the unit should be checked for proper refrigerant charge.

REMOVING AND INSTALLING A COMPRESSOR

To remove a compressor, proceed as follows:

1. Stop the unit and install a compound gauge.
2. Balance the pressure on the compressor
 - (a) Front-seat the SSV.
 - (b) Start the unit and operate until it shows a good vacuum.
 - (c) Stop the unit and crack the SSV until the vacuum builds up to zero lbs. pressure. Then front-seat the SSV again.
 - (d) Front-seat the DSV.
3. Remove the service valve flange bolts and break the valves away from the compressor body.
4. Remove the compressor base bolts and lift it off the machine base.
5. Take off the fly-wheel at once.

In case the compressor won't pump, proceed as follows:

1. Front-seat the SSV and DSV.
2. Remove the gauge fitting plugs or gauges and allow any refrigerant in the compressor to escape into the air. (If the unit is charged with sulphur dioxide the odor will be very objectionable if the SO₂ is purged into the air. In this case pour some 26% ammonia on a rag and hold close to the fittings where the gas is being purged off. The ammonia will neutralize the SO₂ and kill most of the odor.)
3. Then proceed as in steps 3, 4, and 5 above.

On compressors with a discharge shut-off valve in the head instead of the regular DSV, the general procedure is the same as for a unit with standard service valves. The only exception is, that instead of removing the DSV from the compressor head, the whole cylinder head must be removed from the compressor. The head with its shut-off valve closed is then left on the discharge line to the condenser to trap the refrigerant in the rest of the system while the compressor is being repaired.

Some refrigerators having this type of shut-off valve are as follows:

- | | |
|------------------------------|---------------|
| 1. Some models of Frigidaire | 3. King Kold |
| 2. Some models of Zerozone | 4. Cold Coast |

To re-install a compressor proceed as follows:

1. Put on the fly-wheel.
2. Bolt the compressor in place on the machine base.
3. Use new service valve gaskets, dipped in compressor oil, and bolt the service valves in place.
4. Install a compound gauge on the SSV.
5. Remove the gauge fitting plug from the DSV.
6. Start the compressor and operate until the vacuum will increase no farther. Air in the system will be pumped out thru the open gauge fitting port in the DSV.
7. To remove any remaining air, crack the SSV and allow gas to pass from the suction line thru the compressor and out thru the gauge fitting port in the DSV to the atmosphere. When a strong odor of gas is evident, replace the gauge fitting plug or the pressure gauge, back-seat both valves

OVERHAULING A COMPRESSOR

When overhauling a compressor extreme care must be taken to keep all work absolutely clean and free from moisture. The general procedure is as follows:

1. Clean a space on the work bench.
2. Secure a container in which all bolts and small parts can be placed as they are removed.
3. Center-punch mark the compressor parts before disassembling.
4. Drain out the old oil.
5. Examine all valves and valve seats very carefully. Any valve seats that are not in perfect condition should be lapped until a perfectly smooth clean surface over the entire seat is obtained. They may be lapped on a lapping block using an approved lapping compound or plain Bon Ami and oil. For lapping recessed seats in pistons a disc valve may be used and the lapping compound will be the same as that mentioned above. If this procedure does not restore the valve seat to perfect condition the whole valve plate or piston should be replaced.
6. Replace or lap all valves that are not in perfect condition.
7. Replace or re-surface the shaft seal.
8. Replace worn wrist pins or bearings.
9. Wash all parts thoroughly in carbon-tetra-chloride or some other solvent.
10. Lubricate all valves, valve seats, and seal surfaces before reassembling the compressor.
11. When assembling a compressor, it is standard practice to use new gaskets on all parts and to oil both sides of the gasket with clean compressor oil before putting it in place.
12. Be sure to tighten the bolts on the compressor head and housing evenly otherwise leaks, cracked castings or broken bolts may result.
13. After the compressor is assembled, add the correct amount of oil to the crankcase.
14. Connect a short piece of tubing from the DSV to the SSV.
15. Take the compressor to the testing bench, connect it to a motor and operate it for at least an hour.
16. After the running period, check the condition of the compressor with a regular efficiency test. The DSV should be connected to an air pressure hose which will enable the compressor to pump against a head pressure of from 40 to 80 lbs.
17. Check the shaft seal for leaks. This may be done by connecting an SO₂ refrigerant drum to the SSV. This will subject the crankcase and seal to about 40 lbs. pressure. Any leaks may be located by using an ammonia swab. The test may also be made by connecting an air pressure hose to the SSV to build up a 40 lb. pressure in the crankcase. Place the compressor in a pail of water until the shaft seal is submerged. The appearance of bubbles will indicate a leak in which case the seal must be resurfaced again or replaced.
18. If the compressor break-down was due to moisture, it should be taken to the bake oven and dehydrated.
19. Remove the service valves and plug the suction and discharge ports with cork or wooden plugs, Remove the fly-wheel, then return the compressor to the unit and re-install.

In the case of rotary compressors, leaky or defective check valves should be replaced. Broken vane springs should also be replaced.

CHARGING OIL THROUGH THE S.S.V.

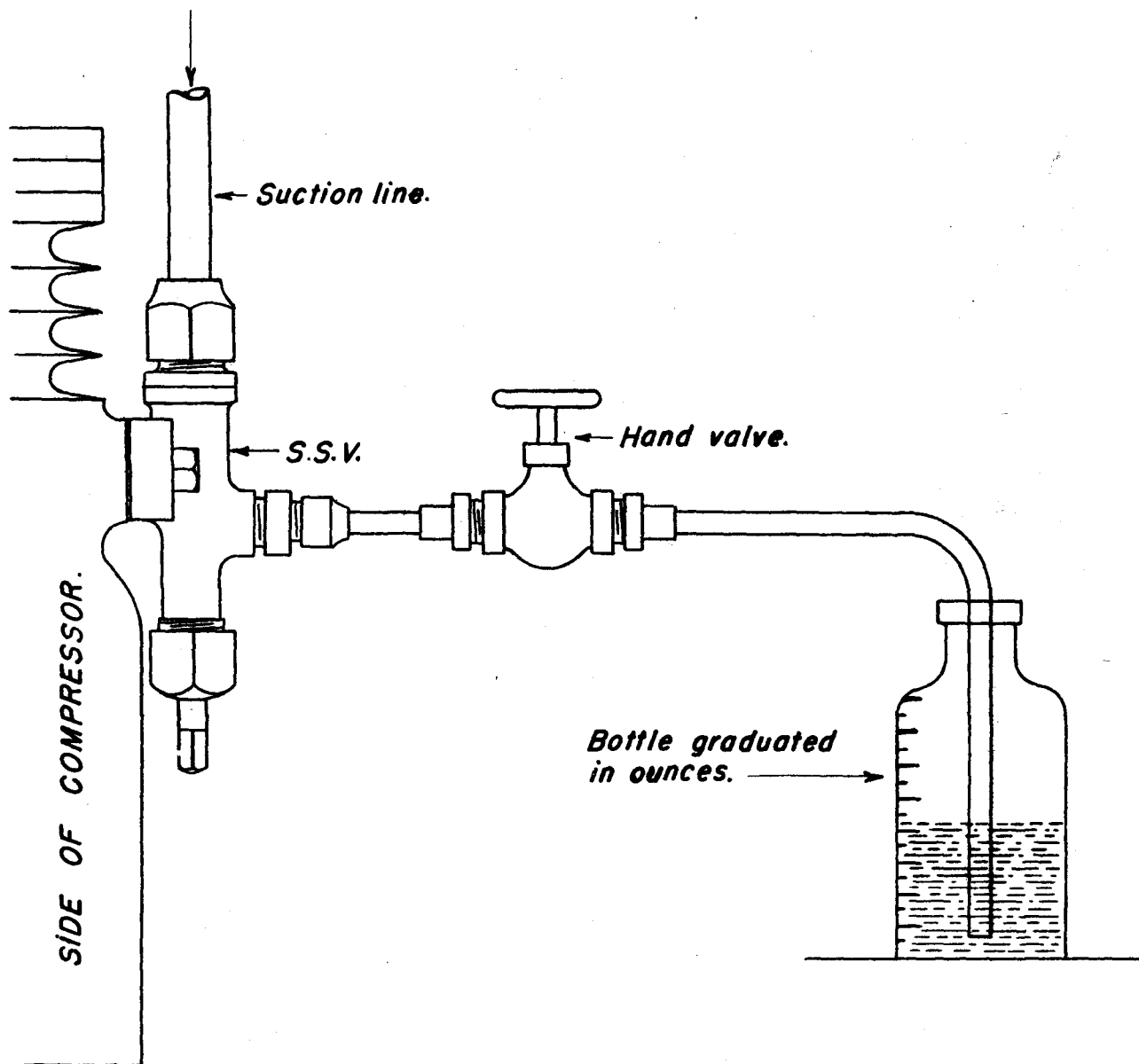

The procedure for charging oil thru the SSV is as follows:

1. Back-seat the SSV and connect a 1/4" copper tube (with a hand valve in this line) from the SSV to the bottom of the oil container.
2. Crack the SSV, open the hand valve and purge the air by blowing it out thru the oil.
3. Close the hand valve, front-seat the SSV and pump a vacuum on the crankcase.
4. Stop the unit, slowly open the hand valve and allow the desired amount of oil to be drawn in.
5. Close the hand valve. Back-seat the SSV and remove the hand valve and tubing.

CHEMICAL DEHYDRATOR.

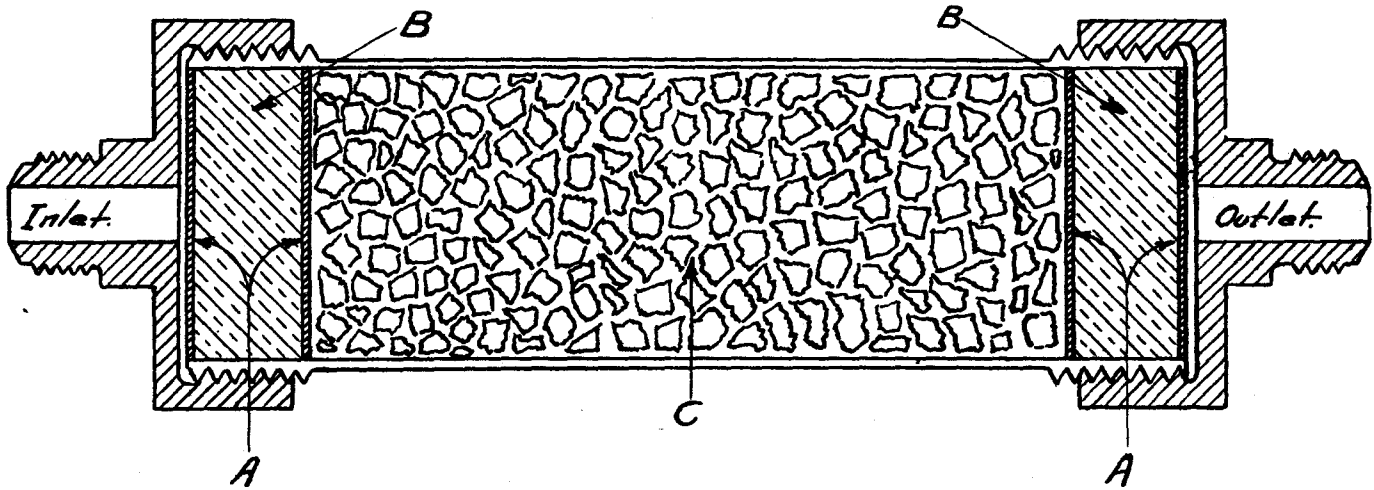

*A-Bronze wire mesh screens. B-Felt filter pads.
C-Drying agent.*

Chemical dehydrators are used in Methyl Chloride and Freon systems to remove moisture. The dehydrator is usually installed in the liquid line at the king valve. It is filled with moisture absorbing chemical which may be one of the following: calcium chloride, calcium oxide, drierite (calcium sulphate) activated alumina, or silica gel.

A comparison of these various dehydrating chemicals is given below

	ADVANTAGES	DISADVANTAGES
Calcium Chloride	Cheap Available in all locations Will absorb large amounts of water	Corrosive to the system if it is left in the system any length of time and if it gets out into the piping system. Will corrode iron and steel parts and also solder joints.
Calcium Oxide	Cheap Efficient Has acid neutralizing value	Breaks down to finely divided particles on absorption of moisture. These particles might get through the filter and into the lines clogging other strainers or filters.
Drierite (Calcium Sulphate)	Reasonable in cost Efficient Can be re-activated by heating	Breaks down into small particles but not as objectionable from this standpoint as calcium oxide.
Activated Alumina	Reasonable in cost Will not break down into finely divided particles Can be re-activated by heating	Not quite as efficient as other driers Does not have as much moisture absorbing capacity as some other agents.
Silica Gel	High Efficiency High moisture absorbing capacity Will not break down Can be re-activated by heating	High Cost

Calcium chloride is sometimes used as a temporary drier to quickly absorb the moisture. It must not be left in the system for longer than a day.

CO-EFFICIENT OF HEAT TRANSFER FROM AIR TO AIR FOR BUILDING CONSTRUCTIONCEILING AND FLOORS

<u>CONSTRUCTION</u>	<u>"K" FACTOR</u>
Plaster ceiling, no flooring55
Plaster ceiling, 4 in. joist, 1 in. flooring44
Plaster ceiling, 4 in. joist, 1 in. flooring, 2 in. filled insulation. . .	.14
4 in. concrete. No flooring or ceiling.51
8 in. concrete. No flooring or ceiling.41
4 in. concrete, 1 in. flooring. Plaster direct to underside concrete. . .	.34
4 in. concrete, 1 in. flooring. Suspended metal lath and plaster ceiling. .	.19

PARTITIONS

Single glass partition75
Double glass partition50
Single wall metal partition.91
Double wall metal partition.53
1 in. wood door in partition43
Metal lath and plaster to one side of studding55
Metal lath and plaster both sides of studding.33
Metal lath and plaster both sides, 1/2 in. insulation between studs.18
Metal lath and plaster both sides, 2 in. filled insulation12
4 in. hollow tile, no plaster.39
4 in. hollow tile, plaster both sides.33
4 in. brick, plaster both sides.37

EXTERIOR WALLS

Wood siding, sheathing, 2 in. X 4 in. studs, wood lath and plaster26
Wood siding, sheathing, 2 in. X 4 in. studs, wood lath and plaster, filled insulation11
Wood siding, sheathing, 2 in. X 4 in. studs, wood lath and plaster, 1/2 in. insulation between studs15
Brick veneer, sheathing, studding, plaster on wood lath.25
Stucco, 1 in. wood sheathing, studding, plaster on wood lath30
Stucco on 8 in. hollow tile, 3/4 in. plaster on metal lath, furred23
Stucco on 8 in. concrete, 3/4 in. plaster on metal lath, furred.30
8 in. brick, no interior finish.39
8 in. brick, 3/4 in. plaster on metal lath, furred26
12 in. brick, 3/4 in. plaster on metal lath, furred.22
Brick veneer 8 in. hollow tile, no interior finish26
Brick veneer, 8 in. hollow tile, plaster on metal lath, furred20
Brick veneer, 8 in. concrete, no interior finish36
Brick veneer, 12 in. concrete no interior finish33
6 in. concrete, no exterior, no interior finish.58
12 in. concrete, no exterior, no interior finish41
Window glass	1.13
Double window glass.45
1 in. door to outside (25/32 in. thick).69
1 1/2 in. door to outside (1-5/16 in. thick)52
2 in. door to outside (1-5/8 in. thick).46

LIST OF REFRIGERANTS USED IN HOUSEHOLD REFRIGERATORS. THIS DOES NOT APPLY TO ALL COMMERCIAL UNITS.

TRADE NAME OF UNIT	REFRIGERANT USED	TRADE NAME OF UNIT	REFRIGERANT USED
Atwater Kent	- Sulphur Dioxide	M & E	- Sulphur Dioxide
Absopine	- Methyl Chloride	Mayflower	- Sulphur Dioxide
Alpinice	- Sulphur Dioxide	Mitycold	- Sulphur Dioxide
Allison	- Ethyl Chloride	Modern	- Sulphur Dioxide
Apex	- Sulphur Dioxide	Motorfrigerator	- Ethyl Chloride
Audiffren	- Sulphur Dioxide	Nizer	- Sulphur Dioxide
Auto-Electric	- Methyl Chloride	Niagara	- Sulphur Dioxide
Buckeye	- Sulphur Dioxide	National	- Sulphur Dioxide
Bohn	- Sulphur Dioxide	Napier	- Methyl Chloride
Baker	- Methyl Chloride	Norge	- Sulphur Dioxide
Belding Hall	- Sulphur Dioxide	O'Keefe & Merritt	- Methyl Chloride
Brenner	- Sulphur Dioxide	Parker	- Sulphur Dioxide
Brunswick	- Methyl Chloride	Peerless	- Methyl Chloride
Bryant	- Sulphur Dioxide	Polaraire	- Sulphur Dioxide
Calectro Frost	- Sulphur Dioxide	Polaris	- Sulphur Dioxide
Carefree	- Sulphur Dioxide	Powerhold	- Ethyl Chloride
Claygo	- Sulphur Dioxide	Royal	- Sulphur Dioxide
Crosley	- Sulphur Dioxide	Remonte	- Sulphur Dioxide
Conservador		Rice	- Methyl Chloride
(Fairbanks Morse)	- Sulphur Dioxide	Romeson	- Sulphur Dioxide
Cold Spot	- Sulphur Dioxide	Rotax	- Sulphur Dioxide
Childare	- Methyl Chloride	Stewart Warner	- Sulphur Dioxide
Cavalier	- Sulphur Dioxide	Sanitary	- Sulphur Dioxide
Calvert	- Sulphur Dioxide	Snow Bird	- Sulphur Dioxide
Chilrite	- Sulphur Dioxide	Sparton	- Sulphur Dioxide
Champion	- Sulphur Dioxide	Sanat	- Sulphur Dioxide
California Pride	- Sulphur Dioxide	Savage	- Methyl Chloride
Cir-cul-air	- Sulphur Dioxide	Silica Gel	- Sulphur Dioxide
Clinton	- Methyl Chloride	Sunbeam	- Sulphur Dioxide
Climax	- Methyl Chloride	Servel	- Methyl Chloride
Coldak	- Ethyl Chloride	Simplex	- Ethyl Chloride
Copeland	- Isobutane	Smith	- Sulphur Dioxide
Copeland		Sure Cold	- Sulphur Dioxide
(Later than 1933)	- Methyl Chloride	Socold	- Sulphur Dioxide
Electro Kold	- Sulphur Dioxide	Starfreeze	- Sulphur Dioxide
Electro Vacuum	- Sulphur Dioxide	Staycold	- Sulphur Dioxide
Electro Frost	- Sulphur Dioxide	Stewart	- Sulphur Dioxide
Electric	- Sulphur Dioxide	Stroh	- Sulphur Dioxide
Eskimo	- Methyl Chloride	Stroh Commercial	- Methyl Chloride
Evercold	- Sulphur Dioxide	Superior	- Sulphur Dioxide
Everite	- Sulphur Dioxide	Temprite	- Sulphur Dioxide
El-Frig-Ette	- Sulphur Dioxide	Tricold	- Methyl Chloride
Excelsior	- Methyl Chloride	Trucold	- Sulphur Dioxide
Federal	- Sulphur Dioxide	Trupar	- Sulphur Dioxide
Femcold	- Methyl Chloride	Truscon	- Methyl Chloride
Frankenberg	- Sulphur Dioxide	Universal Cooler	- Sulphur Dioxide
Frezel	- Sulphur Dioxide	Universal Cooler	- Freon
Frezel Commercial	- Methyl Chloride	Universal Cooler	
Frigair	- Sulphur Dioxide	(1/4 H.P. Over)	- Methyl Chloride
Frigidaire	- Sulphur Dioxide	Ward	- Methyl Chloride
Frigidaire	- F12 or F114	Wayne	- Sulphur Dioxide
Frigid Zone	- Sulphur Dioxide	Welsbach	- Ethyl Chloride
Frig-O-Matic	- Sulphur Dioxide	Frost Kist	- Sulphur Dioxide

TRADE NAME OF UNIT	REFRIGERANT USED	TRADE NAME OF UNIT	REFRIGERANT USED
Maricold	- Sulphur Dioxide	Frozone	- Methyl Chloride
Mechana-Kold	- Methyl Chloride	Grunow	- Methylene Dichloride
Gilfillian	- Sulphur Dioxide	Ice-O-Matic	- Methyl Chloride
Gibson	- Sulphur Dioxide	International	- Ethyl Chloride
Grennell	- Sulphur Dioxide	Iron Mountain	- Sulphur Dioxide
Gen. Elec.	- Sulphur Dioxide	Isko	- Sulphur Dioxide
G.F. 1934 & 1935	- Methyl Formate	Iroquis	- Ethyl Chloride
Gen. Necessities	- Methyl Chloride	Jack Frost	- Sulphur Dioxide
Glemn	- Methyl Chloride	Jewell	- Sulphur Dioxide
Gen. Utilities	- Methyl Chloride	Kelvinator	- Sulphur Dioxide
Haines	- Sulphur Dioxide	Kellog	- Sulphur Dioxide
Hart & Burmeister	- Sulphur Dioxide	Kulair	- Sulphur Dioxide
Hostess	- Sulphur Dioxide	King Boreas	- Sulphur Dioxide
Hoven	- Methyl Chloride	Keokuk	- Sulphur Dioxide
Holmes	- Ethyl Chloride	Keyrex	- Sulphur Dioxide
Holbrook	- Sulphur Dioxide	King Kold	- Sulphur Dioxide
Howe	- Methyl Chloride	Leonard	- Sulphur Dioxide
Hvid & Snow Queen	- Methyl Chloride	Lectric Ice	- Sulphur Dioxide
H.C.M.	- Sulphur Dioxide	Lincoln	- Sulphur Dioxide
Iceaire	- Sulphur Dioxide	Liberty	- Methyl Chloride
Iceberg	- Methyl Chloride	Linde	- Sulphur Dioxide
Iceland	- Sulphur Dioxide	Lihyeo	- Sulphur Dioxide
I. C. S.	- Sulphur Dioxide	Majestic	- Sulphur Dioxide
Icelect	- Sulphur Dioxide	Mohawk	- Methyl Chloride
Icemaster	- Methyl Chloride	Westinghouse	- Sulphur Dioxide
Icerator	- Methyl Chloride	1937 & 1938	- Freon
Ideal	- Methyl Chloride	Whitehead	- Methyl Chloride
Illinois	- Sulphur Dioxide	Zero Air	- Sulphur Dioxide
Ice Maid	- Ethyl Chloride	Zerozene	- Sulphur Dioxide
Indian	- Methyl Chloride	Zero-Ice	- Sulphur Dioxide
		Z-ro	- Ethyl Chloride
Mills	- Methyl Chloride	Dr. Price	- Sulphur Dioxide

LIST OF TOOLS AND SUPPLIES NEEDED FOR REFRIGERATION SERVICE

1 Set of flaring tools. 1 Tube Cutter. 1 Set of Tube Benders
 (Spring type) 1 Set open end wrenches (3/8" to 1-1/2")
 1 Set 12 Point Box Socket Wrenches 1 6" Screwdriver
 1 10" Screwdriver 1 pr. 8" side cutting pliers 1 Wheel puller
 1 Set Allen "Set Screw" wrenches 1 small Pipe wrench (8")
 1 6" thin model adjustable wrench 1 10" thin model adjustable wrench
 1 Ratchet valve wrench 1 Set valve stem adapters
 1 Packing gland wrench 1 Blow torch 1 Heavy duty soldering iron
 1 Halide leak detector torch 1 Pencil type refrigeration thermometer
 Refrigeration Service Manuals 1 Compound gauge (30" in vac. to 60#)
 1 I. C. C. service drum 1 Gas mask 1 Bottle 26% ammonia
 1 Small can white lead 1 Sheet 1/32" lead gasket material
 1 Sheet 1/32" asbestos gasket material 1 Sheet 1/64" asbestos gasket material
 Dehydrated seamless tubing 1/4, 5/16, 3/8, 1/2 and 5/8
 Assortment of brass tubing fittings such as L's, Tee's, unions, crosses.
 Special fittings: Half Unions, 1/8" pipe, to 1/4" pipe, Half ells, 1/8" pipe to
 1/4" tube 1/8" Street Ells 1/8" Pipe Tees.
 1/8" close nipples 1 pocket mirror 1 flashlight
 1 Pressure gauge 300#

REFRIGERATION

SERVICE LOADS FOR VARIOUS TYPES OF REFRIGERATORS

Temperature difference in degrees Fahrenheit.	USE OF CABINET			
	Florist	Grocery or normal market.	Busy market or fresh killed animals	Restaurant or short order
40 degrees	40.0	65.0	95.0	120.0
50 "	50.0	80.0	120.0	150.0
60 "	60.0	95.0	145.0	180.0
70 "	70.0	114.0	167.0	210.0
80 "	80.0	130.0	190.0	240.0
90 "	90.0	146.0	214.0	270.0

In B.T.U.'s per cubic foot of gross interior per 24 hours. Used in calculating the size unit and evap. for commercial application, for use in selecting evap. coils.

Heat leakage through cabinet walls, windows in B.T.U.'s per sq. ft. of outside wall surface per 24 hours. If wood is not used on both sides of cabinet deduct $\frac{1}{2}$ inch of cork insulation.

Temperature difference in degrees Fahrenheit.	Thickness of insulation (cork or equivalent.)				Glass	
	$2\frac{1}{2}$ "	3"	$3\frac{1}{2}$ "	4"	Double	Triple
					Thickness	
40 degrees	84.0	72.0	64.0	60.0	440.0	280.0
50 "	105.0	90.0	80.0	75.0	550.0	350.0
60 "	126.0	108.0	96.0	90.0	660.0	420.0
70 "	147.0	126.0	112.0	105.0	770.0	490.0
80 "	168.0	144.0	128.0	120.0	880.0	560.0
90 "	189.0	162.0	144.0	135.0	990.0	630.0

On non-frost coils the heat transfer is 300 B.T.U.'s per 24 hours per square foot of evaporator surface.

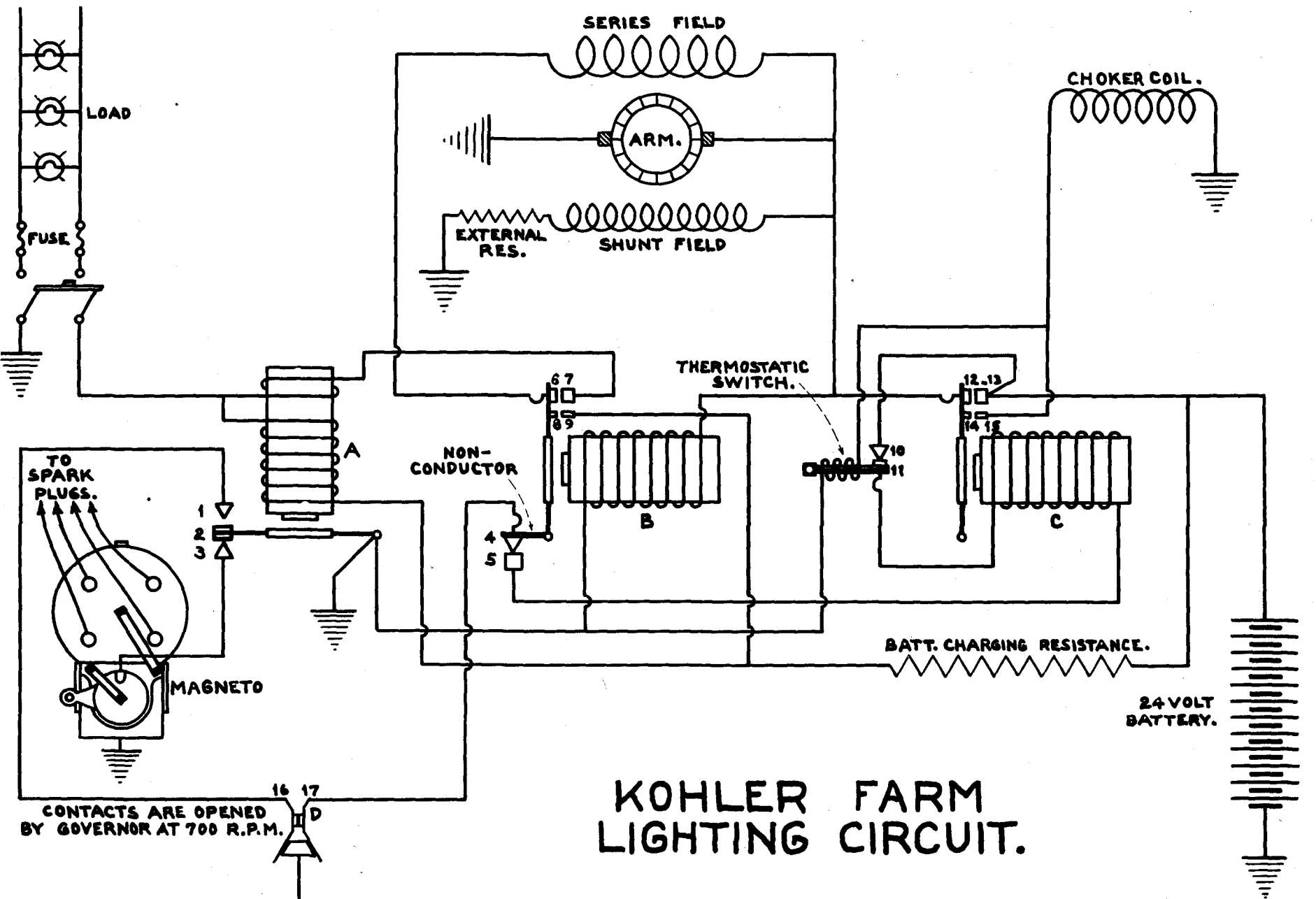

KOHLER FARM LIGHTING CIRCUIT.

CONTACTS ARE OPENED BY GOVERNOR AT 700 R.P.M.

Magnet Charger.

LIST OF MATERIAL.

- 2 SOFT IRON CORES (ROUND) 4" x 2".
- 2 SOFT IRON TOPS 3 3/4" x 3 3/4" x 1/2".
- 1 SOFT IRON KEEPER 8 3/4" x 3 3/4" x 3/4".
- 4 FIBER OR BAKELITE WASHERS 3 3/4" DIA. 2" HOLE 3/16" THICK.
- 4 FLAT-HEAD MACHINE SCREWS 3/8" DIA. 1 1/4" LONG.
- 4 HEXAGON-HEAD MACHINE SCREWS 3/8" DIA. 1 1/2" LONG.
- 500 TURNS #14 S.C.E. MAGNET WIRE ON EACH CORE LAYER WOUND.
- 9 1/2 LBS. COPPER WIRE ARE REQUIRED FOR THE WINDINGS WHICH ARE CONNECTED IN SERIES.

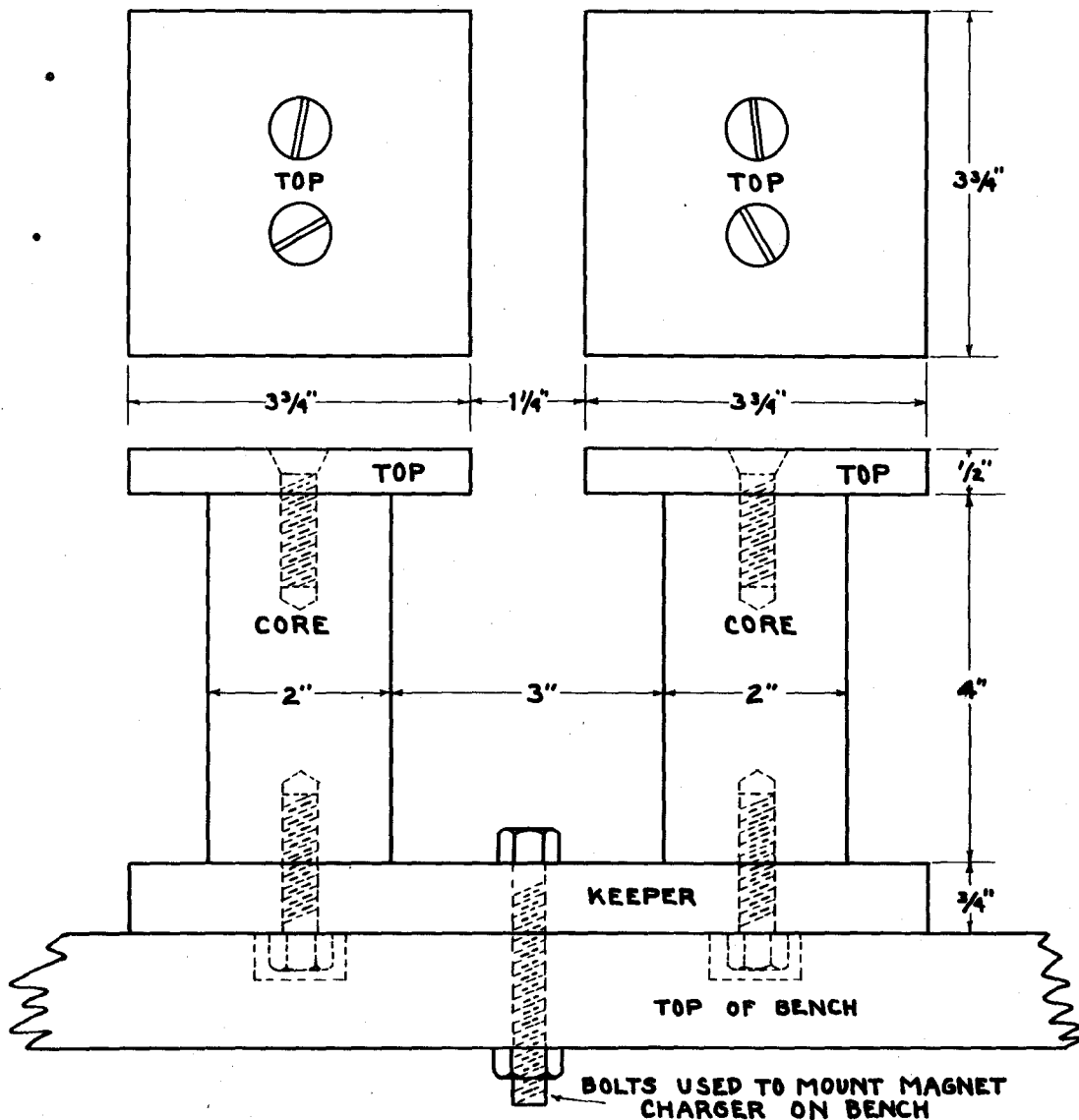
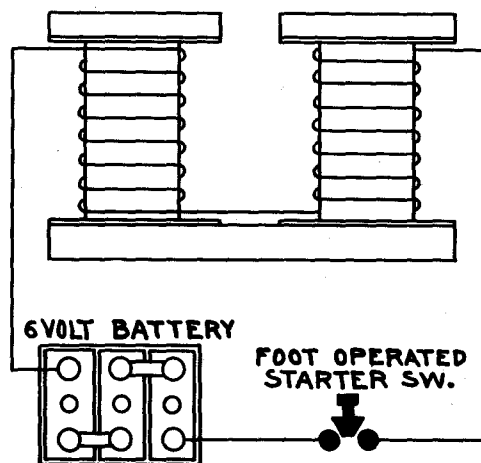

THE INTERNAL COMBUSTION ENGINE - CRANKANGLES AND FIRING ORDERS

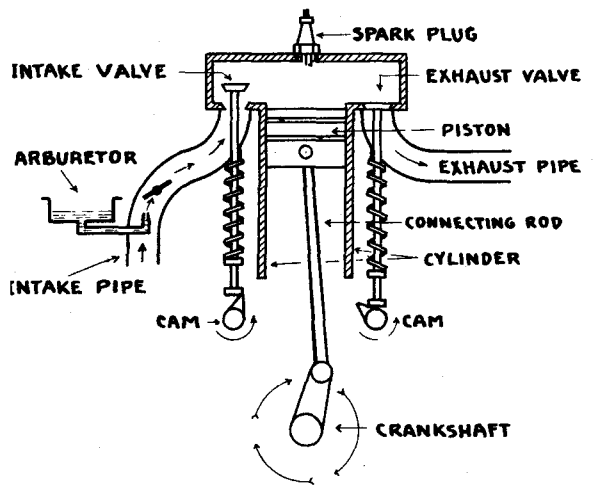

OPERATING PRINCIPLE OF A SIMPLE ONE CYLINDER INTERNAL COMBUSTION ENGINE.

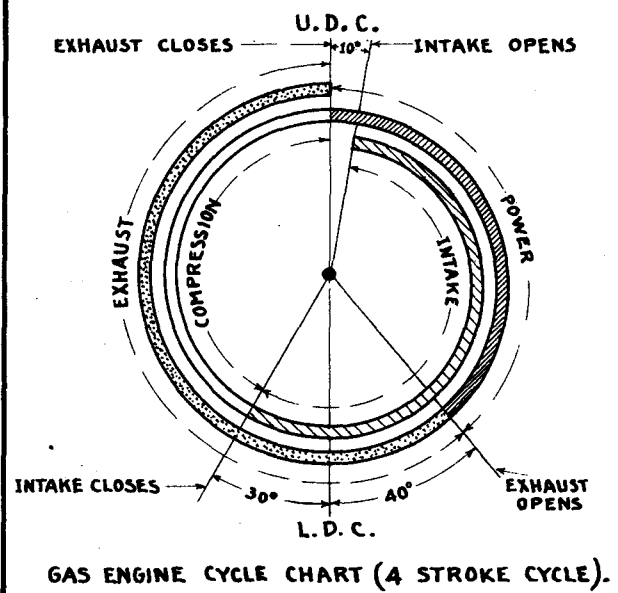

GAS ENGINE CYCLE CHART (4 STROKE CYCLE).

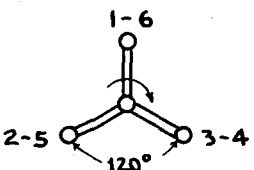
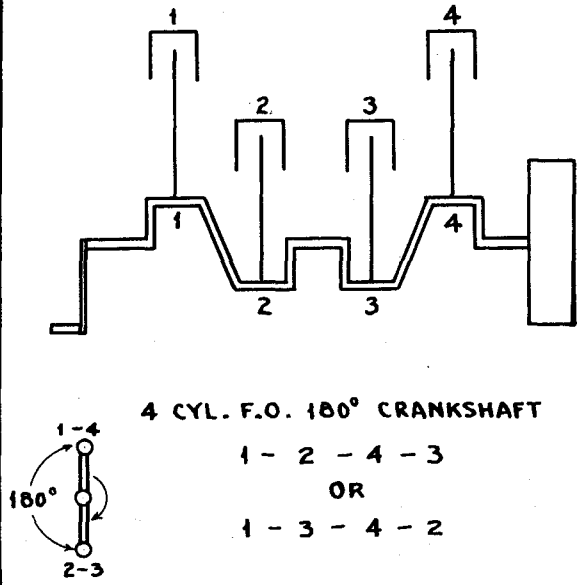

6 CYL. F.O. R.H. CRANKSHAFT
 1 - 5 - 3 - 6 - 2 - 4

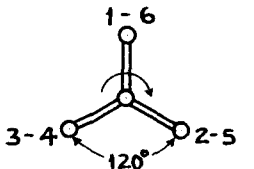

6 CYL. F.O. L.H. CRANKSHAFT
 1 - 4 - 2 - 6 - 3 - 5

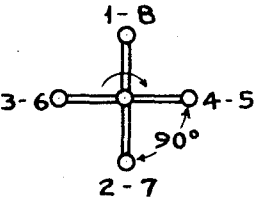

STRAIGHT "8"
 1 - 3 - 2 - 5 - 8 - 6 - 7 - 4
 OR
 1 - 6 - 2 - 5 - 8 - 3 - 7 - 4

V 8 180° CRANKSHAFT
 RIGHT BLOCK 1 - 2 - 4 - 3
 LEFT BLOCK 4 - 3 - 1 - 2
 OR
 RIGHT BLOCK 1 - 3 - 4 - 2
 LEFT BLOCK 4 - 2 - 1 - 3

FORD V 8 90° CRANKSHAFT

4	8
3	7
2	6
1	5
R	L

FIRING ORDER
 1-5-4-8-6-3-7-2

V 12 120° CRANKSHAFT
 RIGHT BLOCK 1 - 5 - 3 - 6 - 2 - 4
 LEFT BLOCK 6 - 2 - 4 - 1 - 5 - 3
 OR
 RIGHT BLOCK 1 - 4 - 2 - 6 - 3 - 5
 LEFT BLOCK 6 - 3 - 5 - 1 - 4 - 2

V 16 90° CRANKSHAFT
 R. BLOCK 1 - 5 - 2 - 6 - 8 - 4 - 7 - 3
 L. BLOCK 8 - 4 - 7 - 3 - 1 - 5 - 2 - 6

OVERLAP CHART FOR 4 STROKE CYCLE ENGINES. POWER STROKE 140° LONG.

4 CYL.

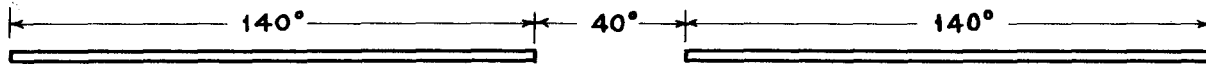

6 CYL.

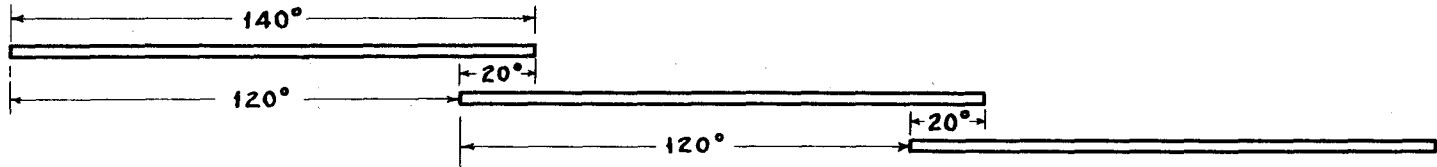

STRAIGHT "8"
90° VEE "8"

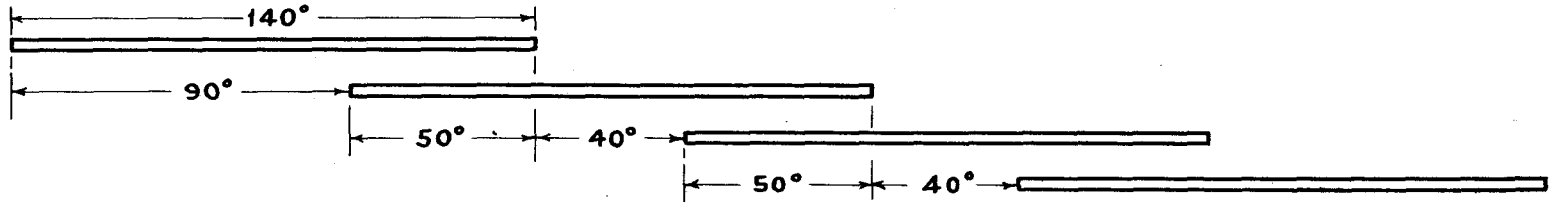

60°
VEE "12"

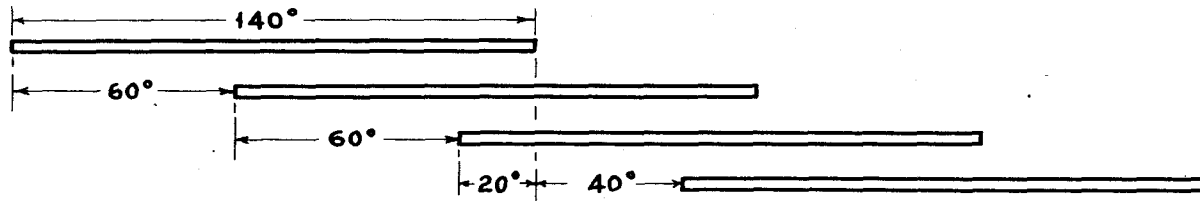

45°
VEE "16"

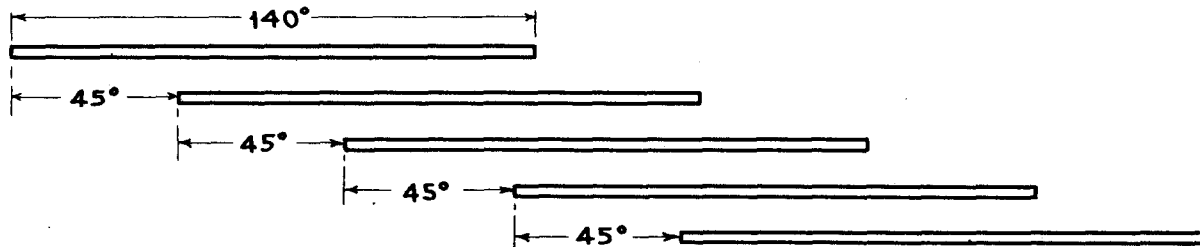

TESTING IGNITION COILS.

COIL TEST CHART

NO. OF COIL	NUMBER OF PRIM. TERMINALS	SECONDARY		CURRENT THROUGH PRIM.	VOLTAGE DROP ACROSS SEC.		SPARK JUMP.
		CONNECTED TO PRIM.	GROUNDED TO COIL CASE		V. M.	WINDING	

A SIMPLE IGNITION SYSTEM

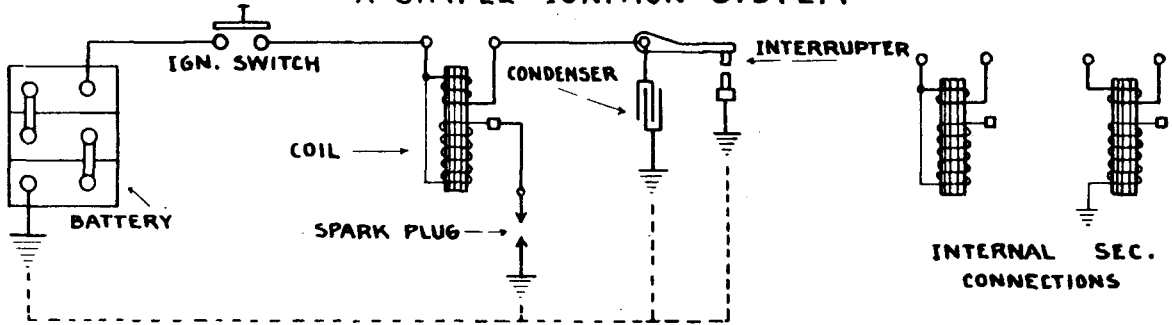

TESTING PRIM.

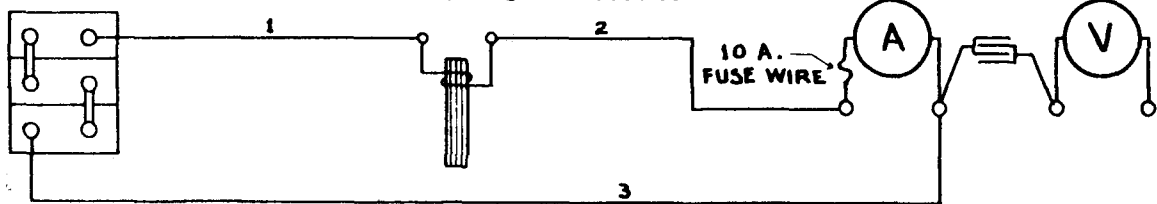

TESTING SEC.

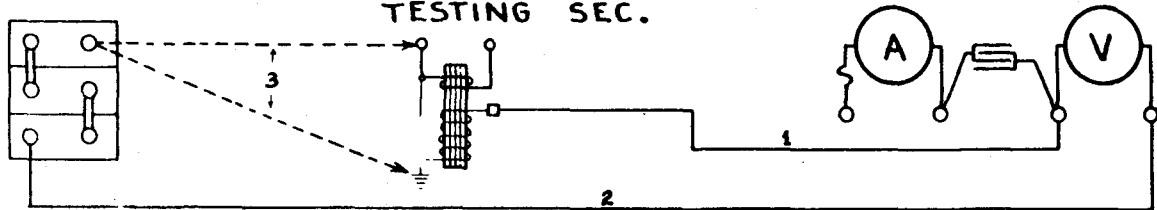

SPARK JUMP TEST

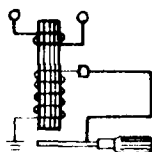
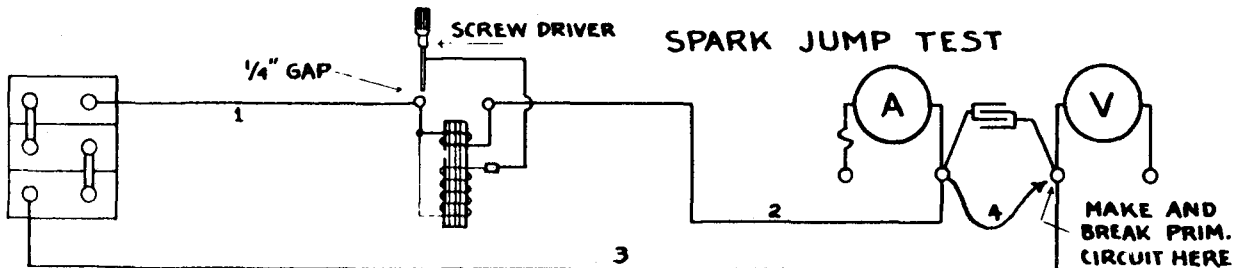

SEC. HOOK-UP IF SEC. IS GROUNDED

STARTING MOTORS

STARTING MOTOR TEST CHART

MAKE OF MOTOR	NO. OF POLES	NO. OF BRUSHES	CHECK CONDITION OF					ON TEST BENCH			DIAGRAM
			FIELDS	ARM.	BRUSHES	BRUSH HOLDER	BEARINGS	AMPS. RUNNING FREE	LOCK TORQUE TEST		
									AMPS.	FT. LBS.	

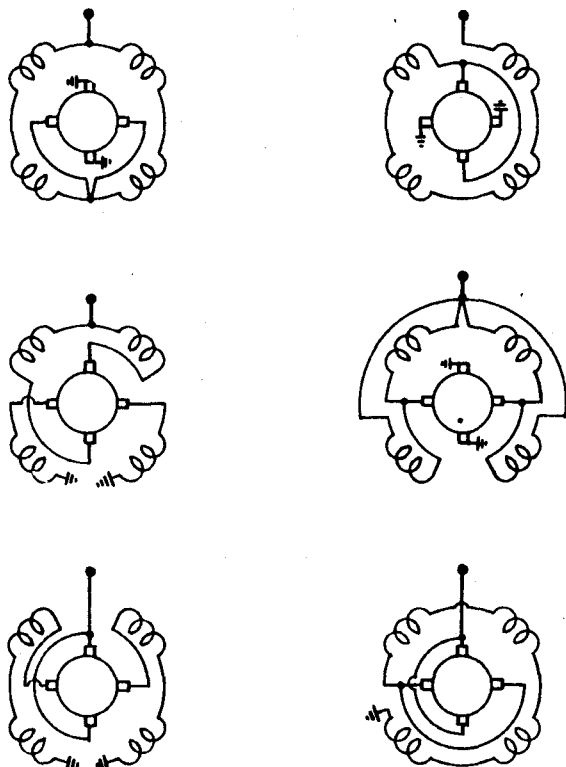
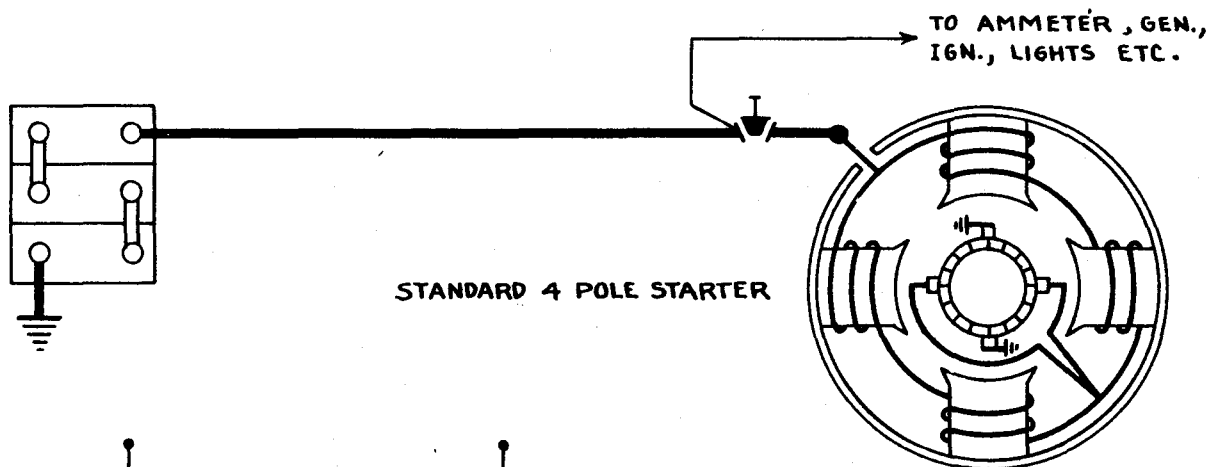

STARTING MOTOR FIELD CONNECTIONS

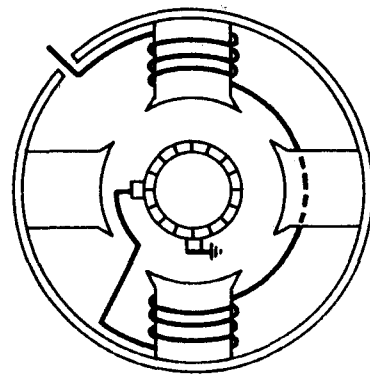

CONSEQUENT POLE STARTER (4 POLE)

THIRD BRUSH GENERATORS

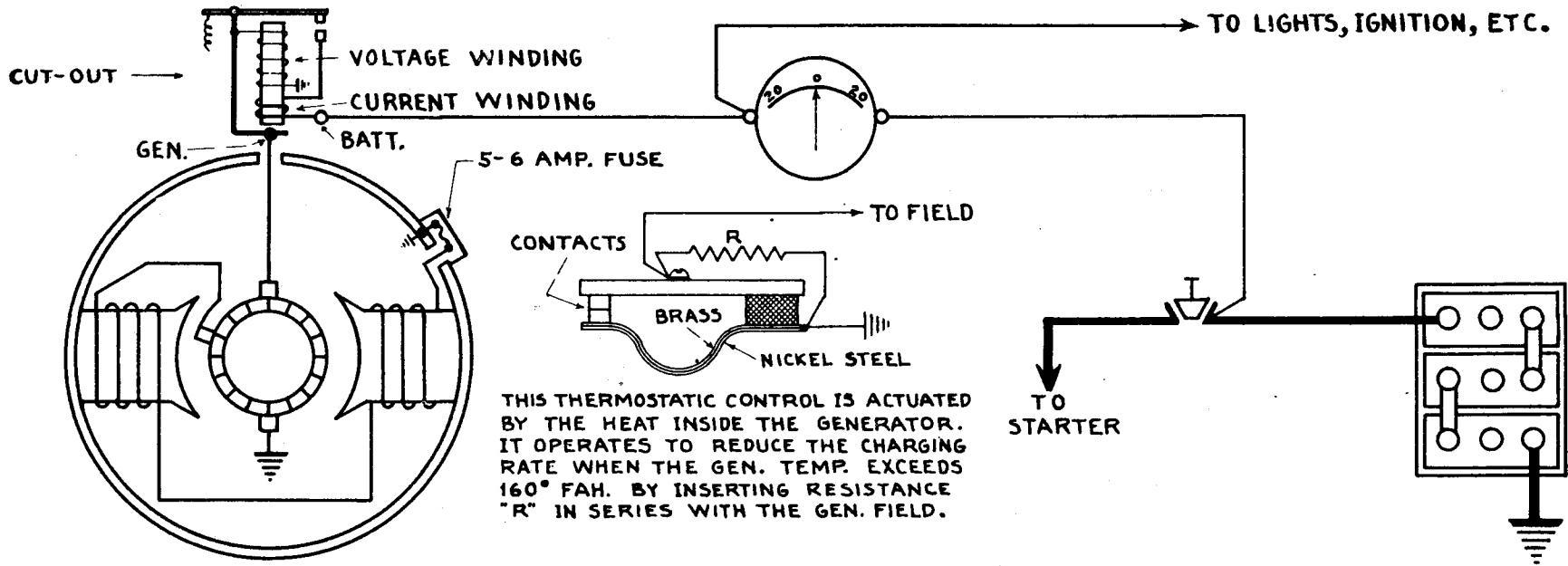

ROTATION AND FIELD CONNECTIONS

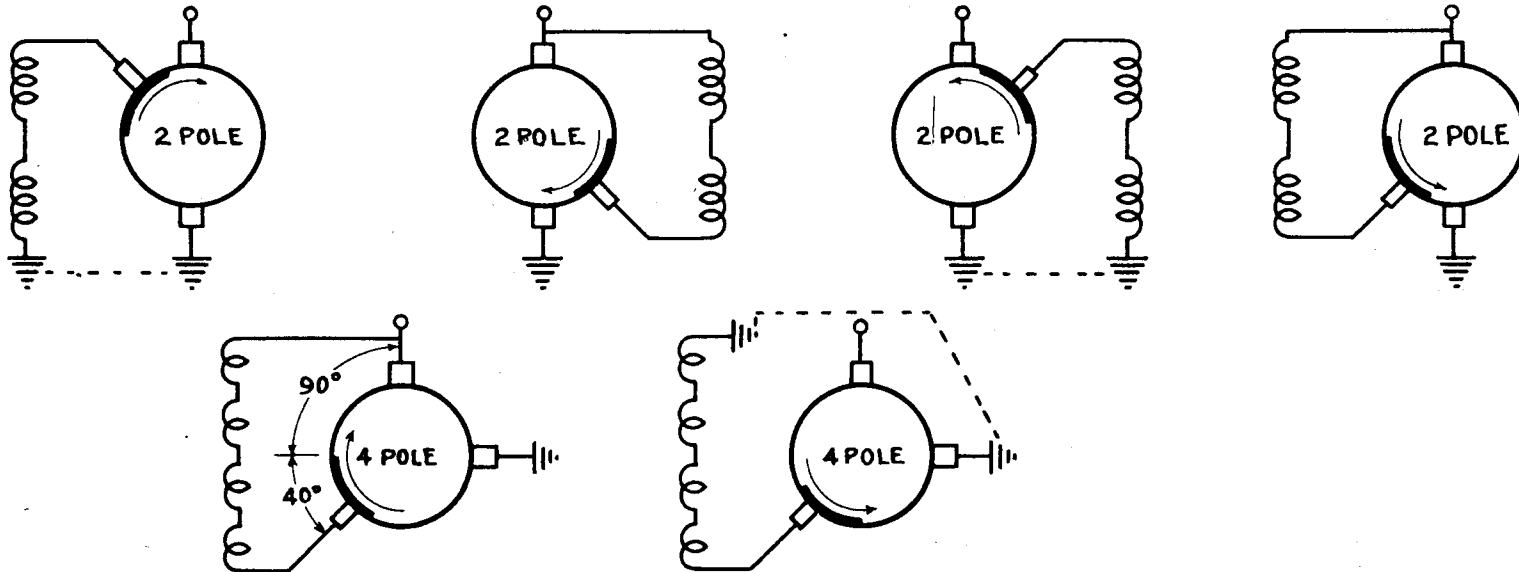

GENERATOR TEST CHART

No. of Generator- - - - -				
Make of generator - - - - -				
No. of poles- - - - -				
No. of brushes- - - - -				
Protection {	Thermostatic- - - - -			
	Fuse- - - - -			
	None- - - - -			
Field {	Open- - - - -			
	Grounded- - - - -			
	E_D across each coil - -			
	Insulation- - - - -			
	Condition of field- - -			
	Armature {	Grounded- - - - -		
Shorted - - - - -				
Opens - - - - -				
Insulation- - - - -				
Brushes {	Worn- - - - -			
	Oil soaked- - - - -			
Brush Holders {	Grounded- - - - -			
	O.K.- - - - -			
Bearings {	Worn- - - - -			
	O.K.- - - - -			
Amps running free- - - - -				
Output Test {	3rd brush retarded	1000 r.p.m.-		
		1500 r.p.m.-		
	3rd brush advanced	1000 r.p.m.-		
		1500 r.p.m.-		

Draw a diagram of each generator tested on back of this sheet.

HIGH TENSION MAGNETO

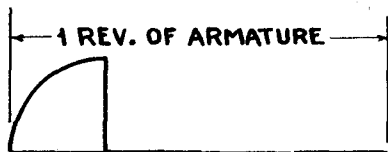

WITH SPARK
ADVANCED
PRIMARY IS
INTERRUPTED WHEN AT MAX. VALUE

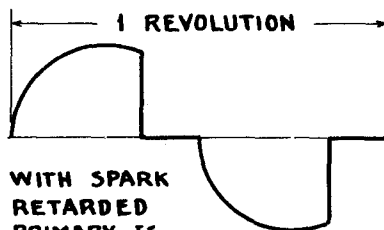

WITH SPARK
RETARDED
PRIMARY IS
INTERRUPTED AFTER REACHING MAX. VALUE

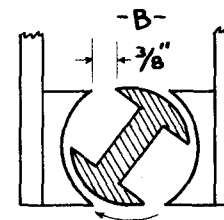
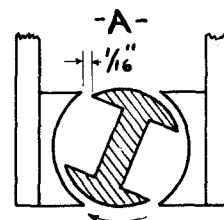

POSITION OF ARMATURE CORE AT TIME OF SPARK
-A- SPARK ADVANCED. -B- SPARK RETARDED.

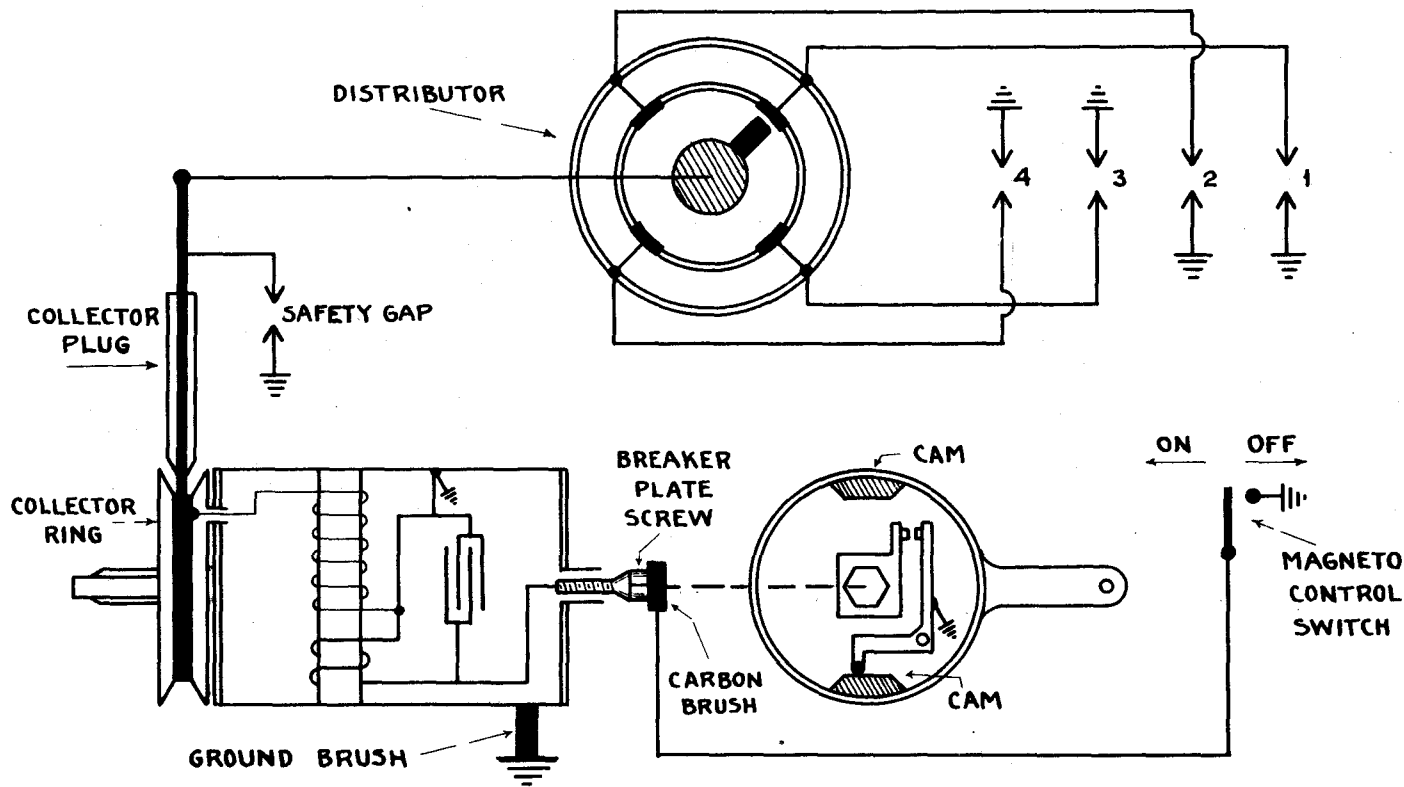
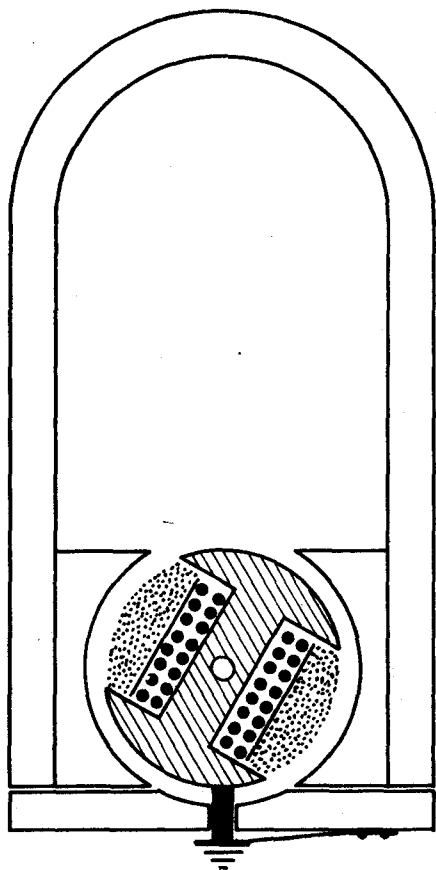

TWO-POLE SCINTILLA ROTATING MAGNET MAGNETO

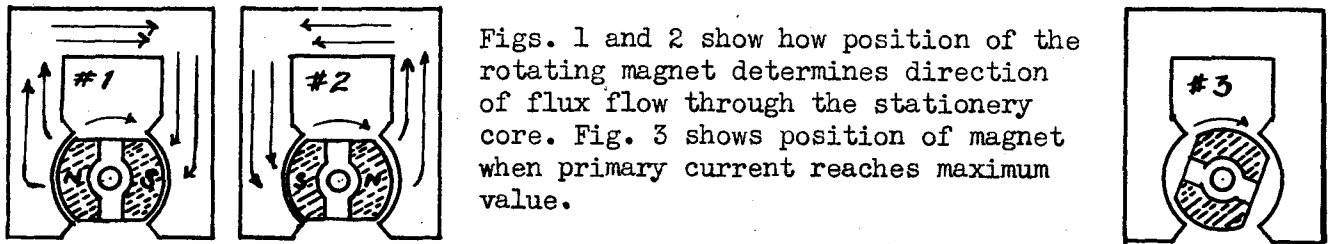
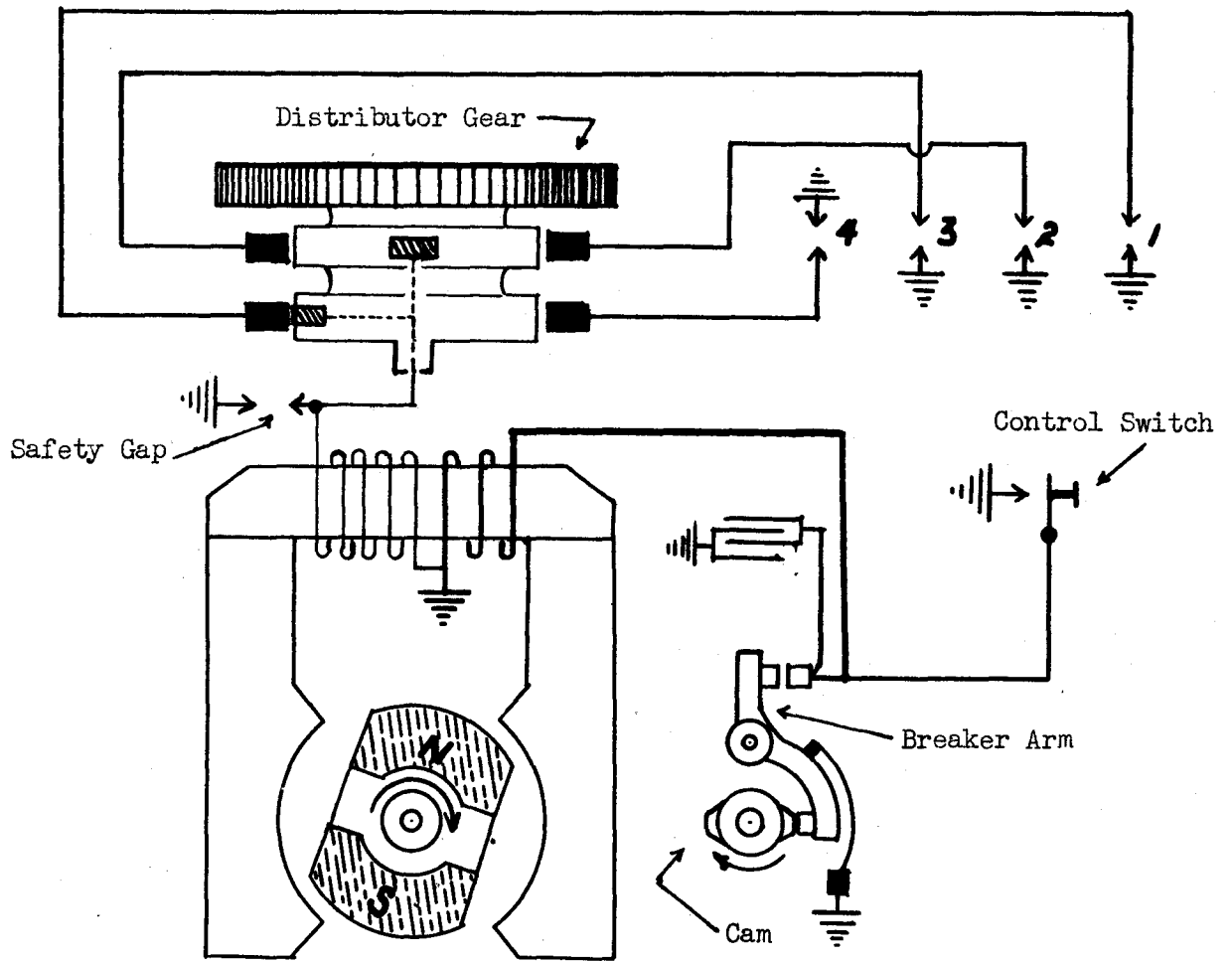

Figs. 1 and 2 show how position of the rotating magnet determines direction of flux flow through the stationary core. Fig. 3 shows position of magnet when primary current reaches maximum value.

PRINCIPLE OF OPERATION

Current is generated in the primary winding by rotating a permanent magnet which produces an alternating magnetic field in the stationary core which supports primary and secondary winding.

For one revolution of the 2-pole rotating magnet, the magnetic flux will change direction 2 times or once every 180°. The primary current will reach maximum value in the primary circuit just as the magnetic flux in the stationary core reverses in direction.

At this point, the 2-lobe cam opens the breaker points and interrupts the primary circuit causing a rapid collapse of the primary magnetic field, which in turn induces a high voltage in the secondary winding.

WICO MAGNETO TYPE E.K. (For Single Cylinder Engines)

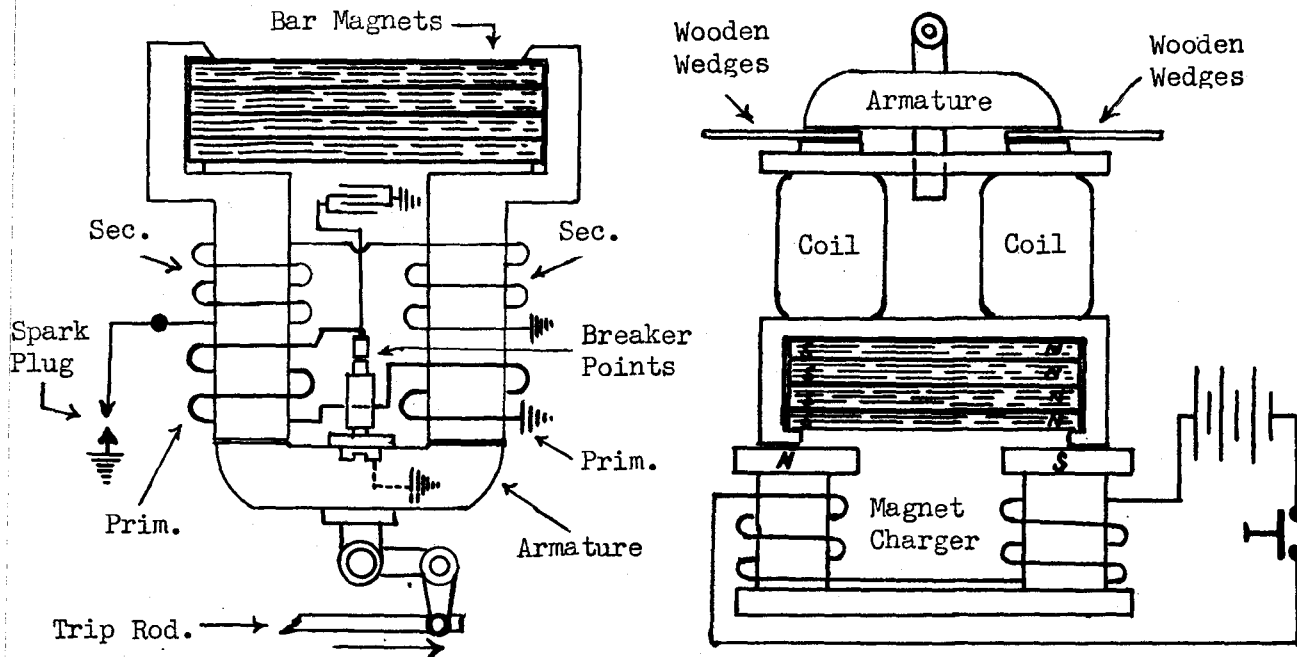

WICO MAGNETO CYCLE OF OPERATION

(TYPE EK)

1. When laminated steel armature is in contact with ends of the stationary cores, a complete magnetic circuit is formed which is energized by a set of bar magnets at opposite end of stationary cores.
2. When armature is pulled away from the ends of the stationary cores, the magnetic circuit is broken, and the magnetic field generated by the bar magnet collapses, cutting across the two primary windings, causing a current to flow in these two windings. This current builds up the primary magnetic field.
3. As the primary current reaches maximum value, which will be when the armature clears the ends of the stationary cores $\frac{3}{32}$ of an inch, the breaker points, one of which is actuated by the moving armature, break the primary circuit, causing the primary magnetic field to collapse and cut across and generate a high voltage in the two secondary windings to which the spark plug is connected. A condenser connected across the breaker points speeds up the collapse of the primary magnetic field and at the same time reduces arcing across the breaker points.

CHARGING MAGNETS

1. Remove outer sheet brass housing.
2. Wedge armature open with wooden wedges $\frac{1}{16}$ of an inch thick.
3. Determine N and S end of bar magnets.
4. Set entire magneto across magnet charger as shown in diagram with N end of bar magnets on South pole of magnet charger.
5. Turn on charger current and charge for 20 to 30 seconds. Strike magnets lightly while charging.
6. Remove wooden wedges.
7. Remove magneto from charger, and re-install outer sheet brass housing.

TESTING MAGNETOS

MAKE OF MAGNETO	No. OF CYL.	ROTATION	CHECK CONDITION OF				ARMATURE			MAGNETS LBS. PULL	
			BREAKER	COLLECTOR RING	BEARINGS	INSULATION	CURRENT THRU. PRI.	VOLTAGE DROP ACROSS SEC.			SPARK JUMP
								V. M.	WINDING		

TEST CIRCUITS

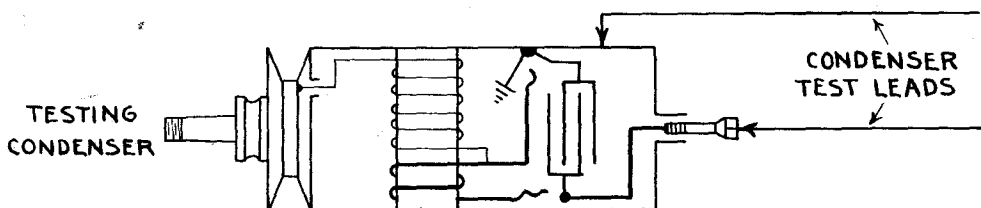
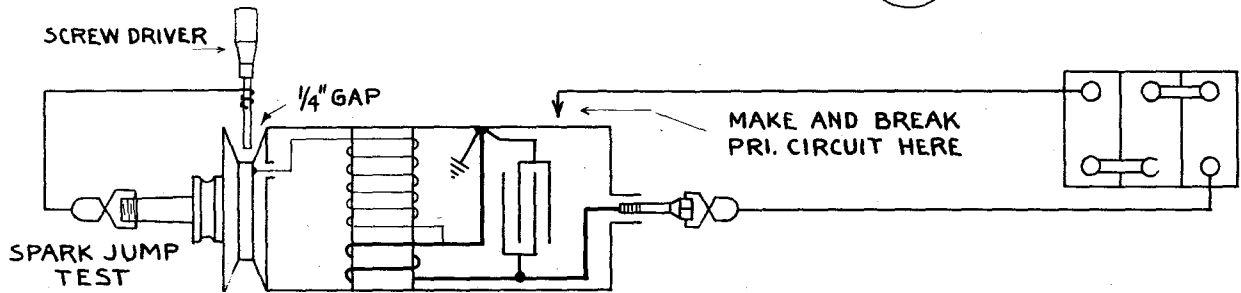
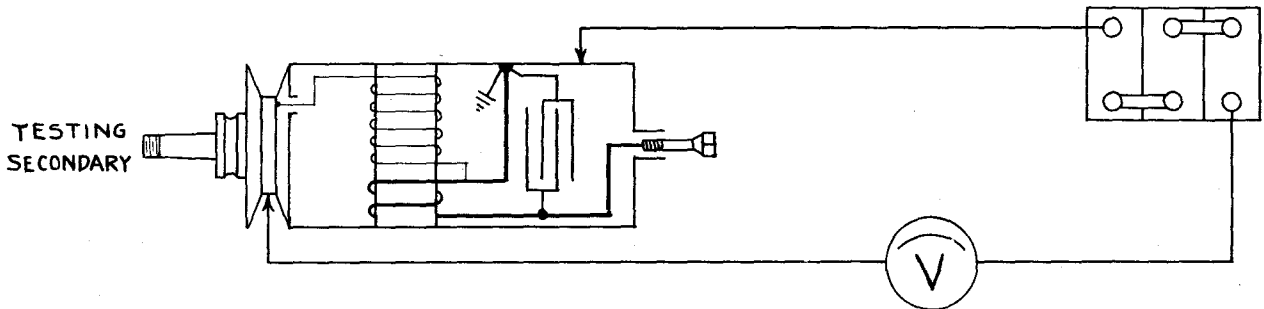
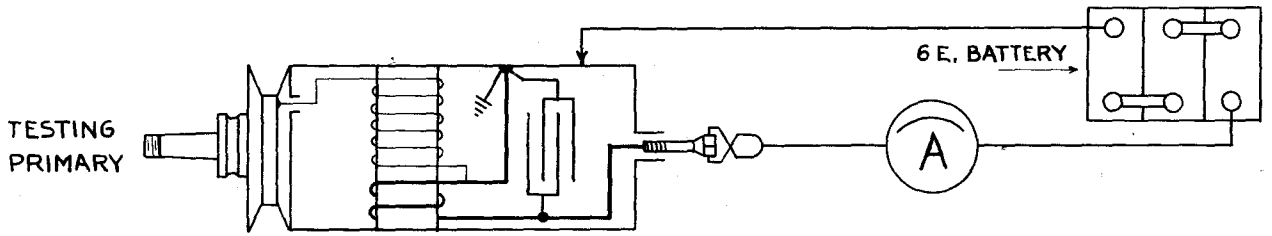

IN ORDER TO TEST COND. PRI. WINDING MUST BE DISCONNECTED AS SHOWN.

BATTERY IGNITION

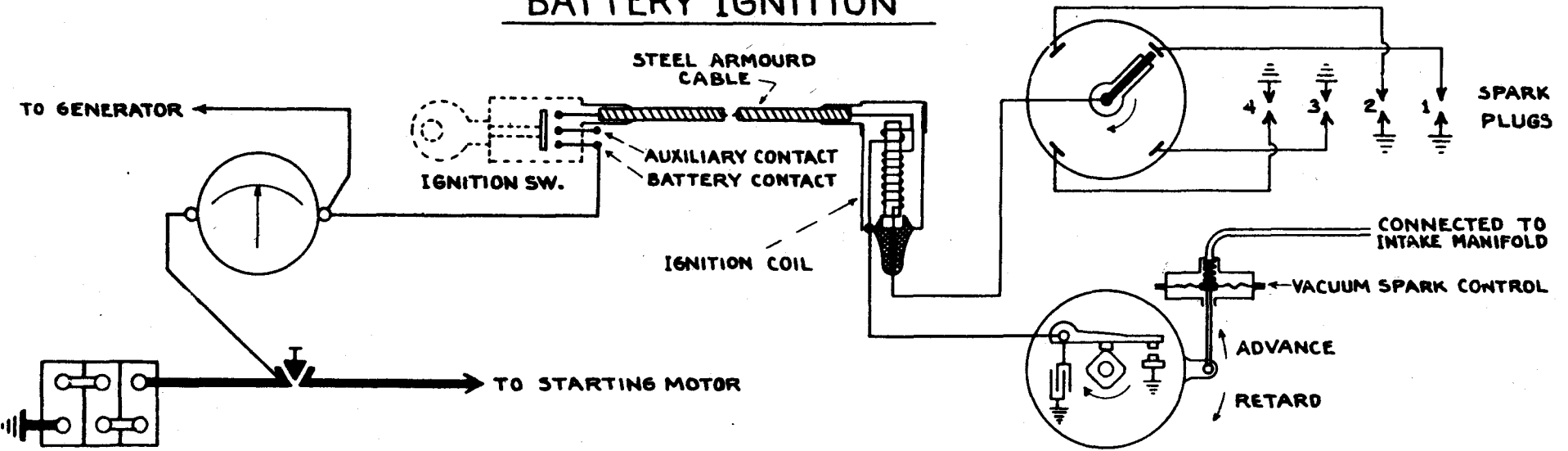

The top diagram shows the connections for a high-speed distributor using one coil on an eight-cylinder engine. Below is shown the same type breaker using two coils and a slightly different arrangement of the secondary rotor arms and distributor cap contacts.

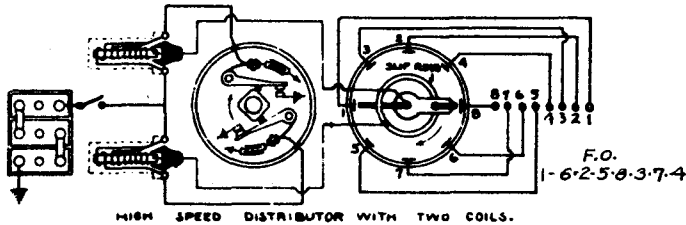
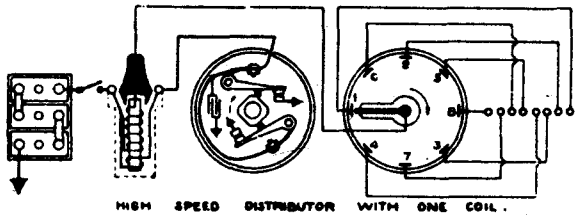

HIGH SPEED DISTRIBUTOR

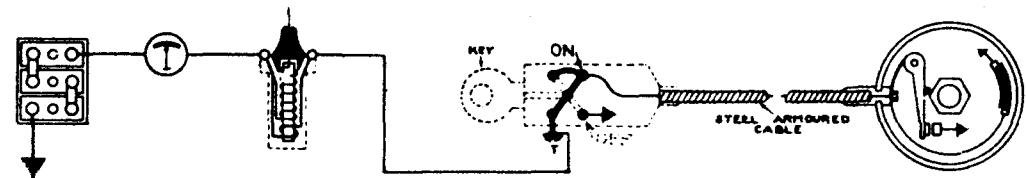
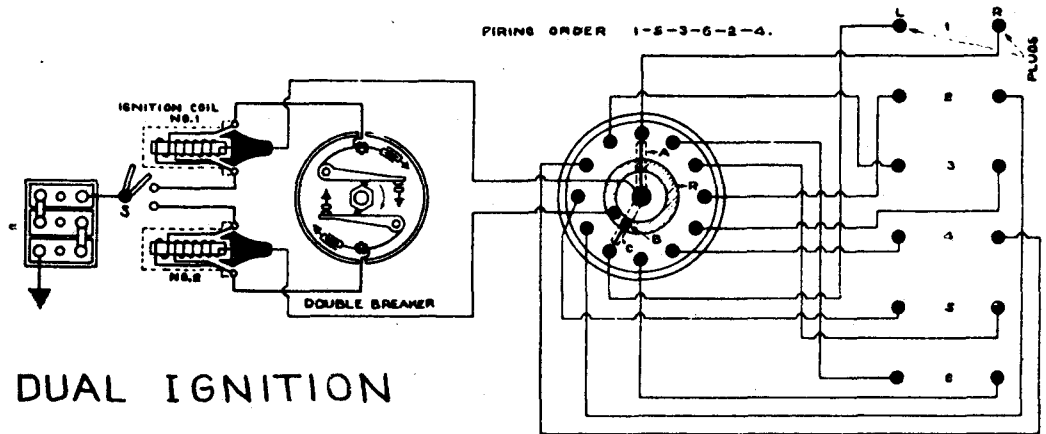

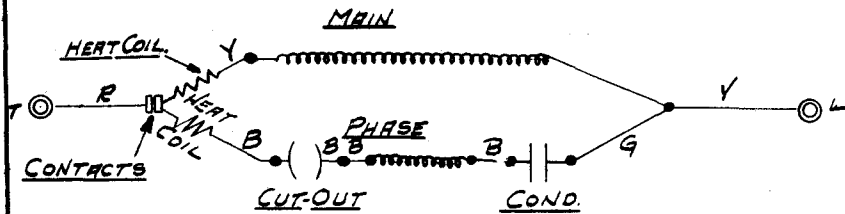

R RED
G GREEN
Y YELLOW
B BLACK
 ● - SOLDER CONNECTIONS
 ○ - EYELET

DRAWN BY <u>R. PERSONS</u> DATE <u>10-28-36</u>	
TRACED BY <u>R. PERSONS</u> DATE <u>10-28-36</u>	
CHECKED BY <u>RO II</u> DATE <u>10-29-36</u>	
R O II 12. 2-36	
CHANGES	
RED LEAD MOVED	12-1-36 J.P.W.
GREEN LEAD MOVED	2-1-37 J.P.W.
MAIN HEATER COIL ROD-ED-	2-1-37 J.P.W.

FOR FRAME ASSEMBLY

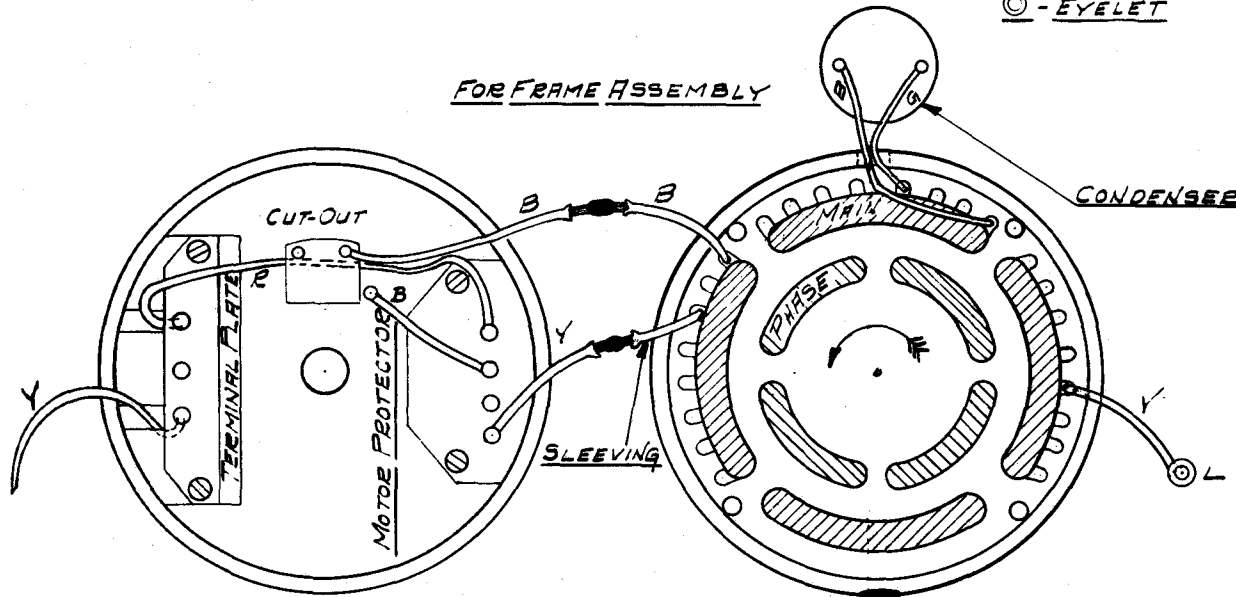

CUT-OUT COVER
VIEW OF INSIDE

FIELD RING CUT-OUT
COVER END
I.E. BUSHING HOLE END

FOR FIELD WINDING

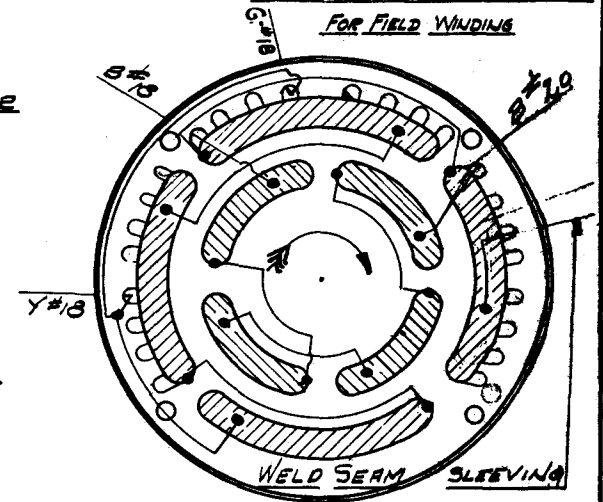

FIELD RING
END OPPOSITE BUSHING HOLE

FIELD DIAG OF CONNS.

FOR KS60

110 VOLTS

THE EMERSON ELECTRIC MFG. CO.

ST. LOUIS, U. S. A.

SCALE 3/8" = 1" No 72894-B

PLACE ALL COILS IN SLOTS
WITH ENDS AT END OF FIELD
RING OPPOSITE TO BUSHING HOLE.

GENERAL IGNITION TIMING RULES

1. Turn engine over slowly until #1 piston is at T.D.C. of the COMPRESSION STROKE, or IGNITION TIMING MARKS line up with TIMING POINTER with #1 piston on COMPRESSION stroke. To determine compression stroke:
 - Method 1. Remove #1 spark plug and feel for pressure with thumb as piston comes up on compression.
 - Method 2. Watch last valve (exhaust valve). As last valve begins to close #1 piston is approaching T.D.C. of the compression stroke.
 Location of ignition timing marks:
 - (A) FRONT FACE of flywheel (viewed through timing window in flywheel housing)
 - (B) ON RIM of crankshaft pulley at FRONT END of engine.
2. Have breaker unit completely installed. Primary lead, spark advance equipment, etc., all connected. BREAKER POINTS adjusted to manufacturer's specifications. (If no data is available set at .018")
3. If octane selector or fuel selector is provided, set at ZERO or MID SLOT. If manual spark advance is used, set manual spark advance control in RETARDED POSITION.

4. Connect 6 volt timing lite in PARALLEL with breaker points. (See Diagram.) Diagram shows two places where timing lite can be connected.

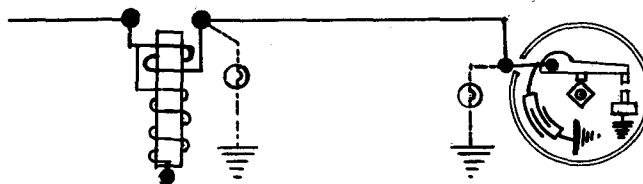

5. Turn ignition "ON".
6. If solid cam type unit: Loosen clamping screw under breaker housing and rotate housing AGAINST normal cam rotations until breaker points just begin to open (6 volt lite lights up) and distributor rotor lines up with distributor contact #1 if cap is numbered, if not numbered any contact segment that the rotor lines up with becomes #1. Tighten clamping screw.

If locked cam type: Loosen breaker cam and rotate WITH normal cam rotation until breaker points begin to open and distributor rotor lines up with distributor contact #1 if cap is numbered. If not numbered, any distributor cap contacts that rotor lines up with becomes #1. Tighten cam locking screw.

7. Install spark plug cables according to numbers on distributor cap or if not numbered according to firing order and rotor rotation.
8. Testing:
 - (A) Shop test: (If timing marks are provided) Connect neon timing lite in SERIES with spark plug #1. Start engine and run at SLOW idle. Hold neon lite so that its flash will illuminate timing pointer. If timing is not correct, correct by LOOSENING and ROTATING housing or cam according to type of unit. DO NOT MAKE CORRECTIONS WITH OCTANE SELECTOR OR FUEL SELECTOR. CORRECTIONS ON SOLID CAM TYPE UNIT MADE WHILE ENGINE IS RUNNING AT SLOW IDLE.
 - (B) Road test: With engine WARM, drive car at 7 - 8 m.p.h., then push throttle wide open. If engine is sluggish, spark is too late. If engine knocks very noticeably, spark is too early. Correct either condition with octane selector or fuel selector. A slight ping should be heard as car speed increases from 10 to 20 m.p.h. on a level road with wide open throttle.

AUXILIARY GENERATOR CONTROLS

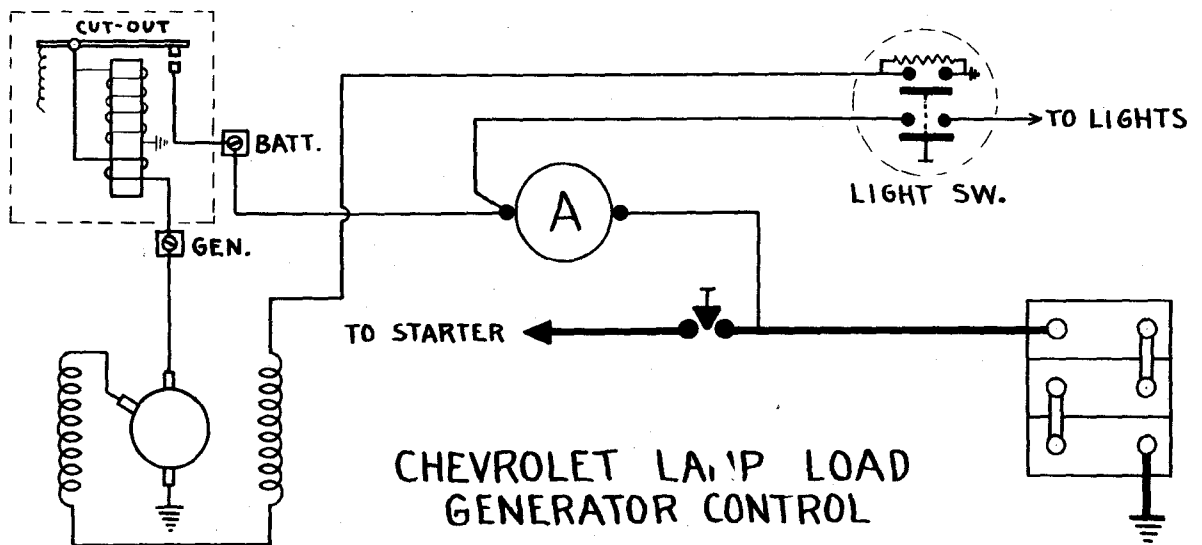
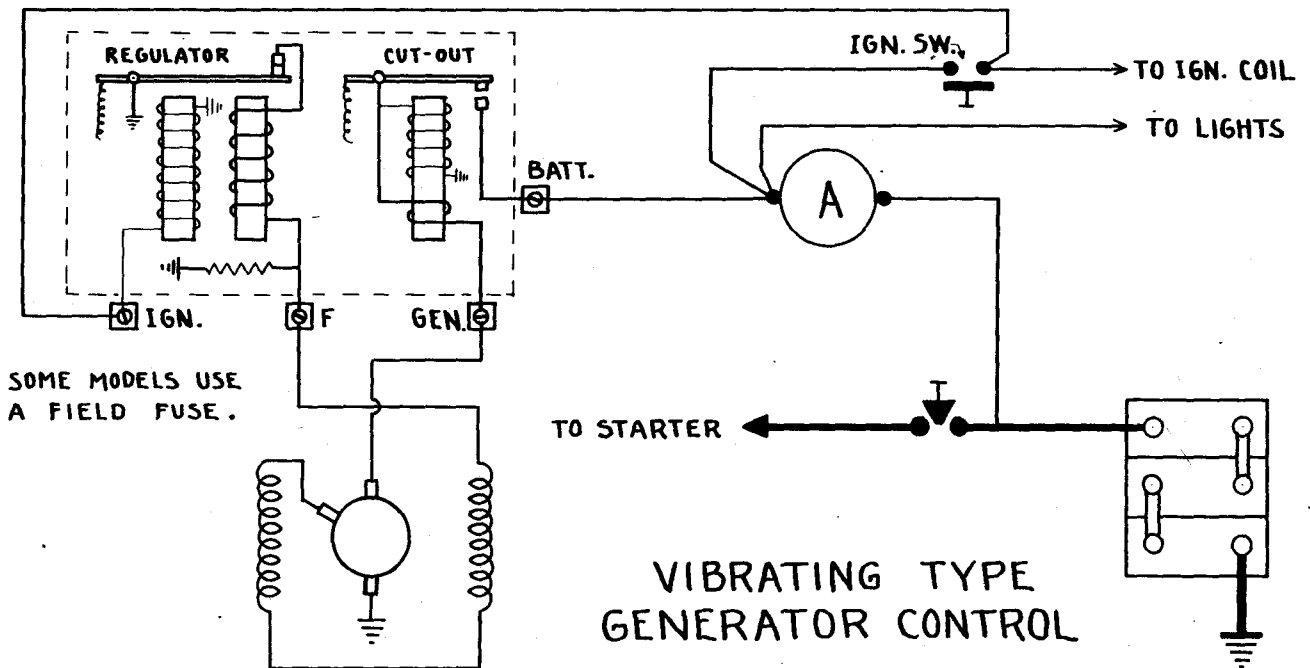
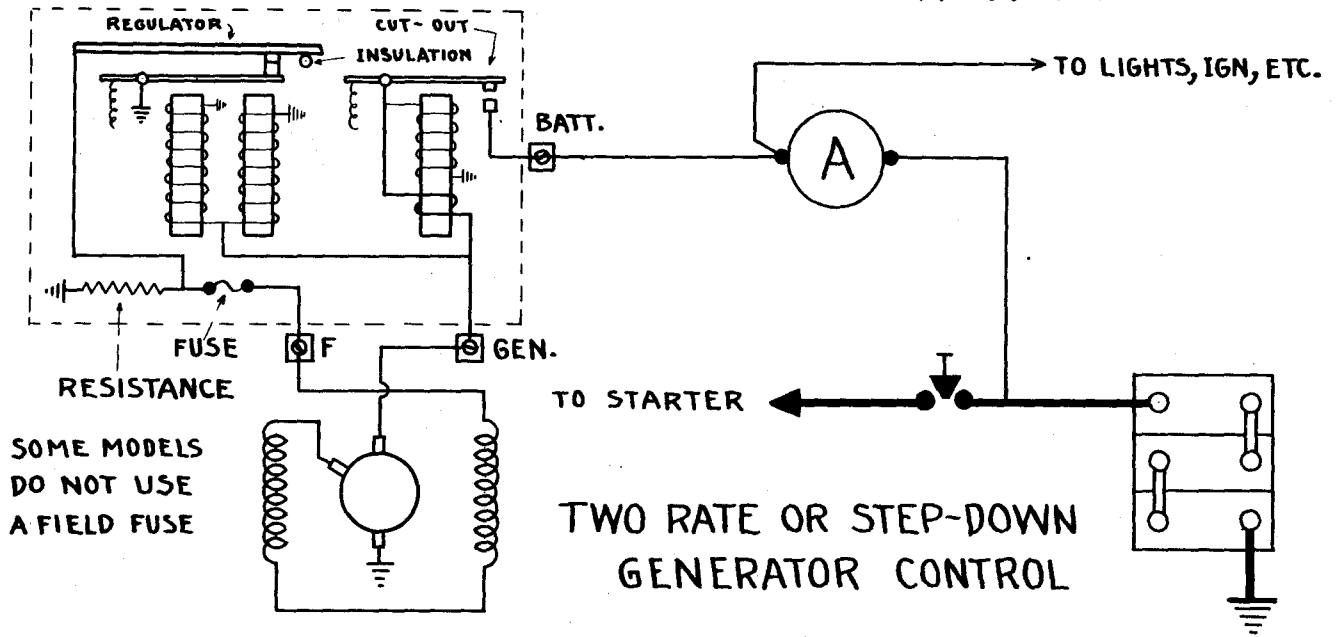

TESTING HOOK-UP FOR 2 RATE OR STEPDOWN GENERATOR

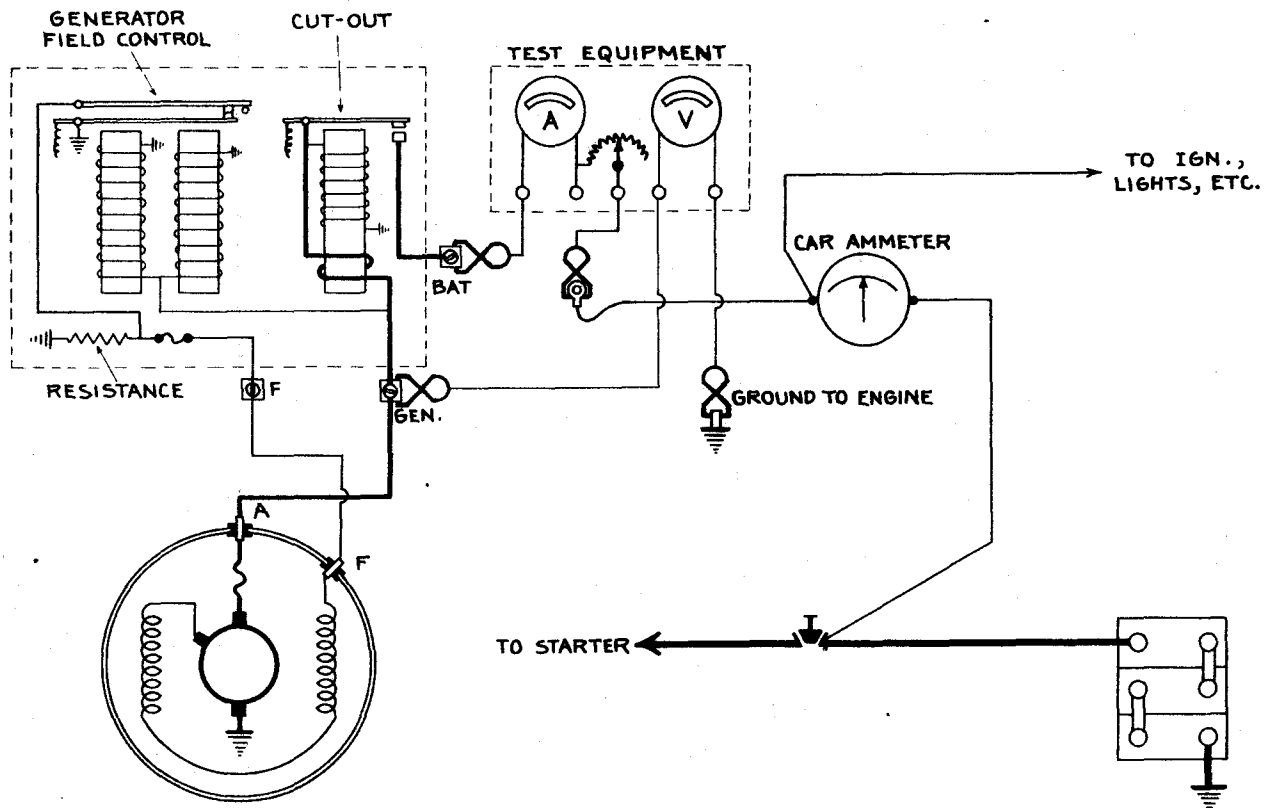

TESTING PROCEDURE - TWO-RATE GENERATOR REGULATOR

Read these instructions carefully and carry out in the order given.

1. Start engine and run until it is warmed up and running smoothly.
2. Ground field terminal on generator, and set engine throttle so that the ammeter on the car indicates maximum output.
3. Check voltage across generator and across battery. (Battery voltage must be checked from center to center of the battery posts.) The difference between the two readings must not exceed .75 of a volt. If the difference is more than .75 of a volt, check the generator circuit for high resistance connections.
4. Stop engine and remove ground from generator field terminal.
5. With engine stopped, disconnect lead from "Bat" or "Amm" terminal on generator cut-out, and connect testing ammeter and rheostat in series with "Bat" or "Amm" terminal and end of lead just disconnected. (See diagram.)
6. Connect one side of testing voltmeter to either "Gen" terminal on cut-out or "A" terminal on the generator. Ground the other side of voltmeter to clean metal surface on engine. (See diagram.)
7. Set ammeter switch for high scale. Voltmeter switch for low scale. Rheostat control, all resistance out.
8. Start engine, and set throttle so that testing ammeter indicates 12-15 amps. If ammeter has reversing switch, idle engine before reversing ammeter.
9. With ammeter indicating 12-15 amps, gradually cut in resistance with rheostat and watch voltmeter. When control contacts open the voltmeter, pointer will drop back slightly. Contacts should open at 8.25 - 8.65 volts. If a manual is available, obtain data from manual. (Important - Regulator cover must be in place when the above test is made, otherwise the test will not be accurate.)
10. If regulator contacts open too early, increase spring tension on regulator, and if too late, reduce spring tension.
11. Stop engine before disconnecting test equipment.

TESTING HOOKUP FOR VIBRATING TYPE GENERATOR CONTROL

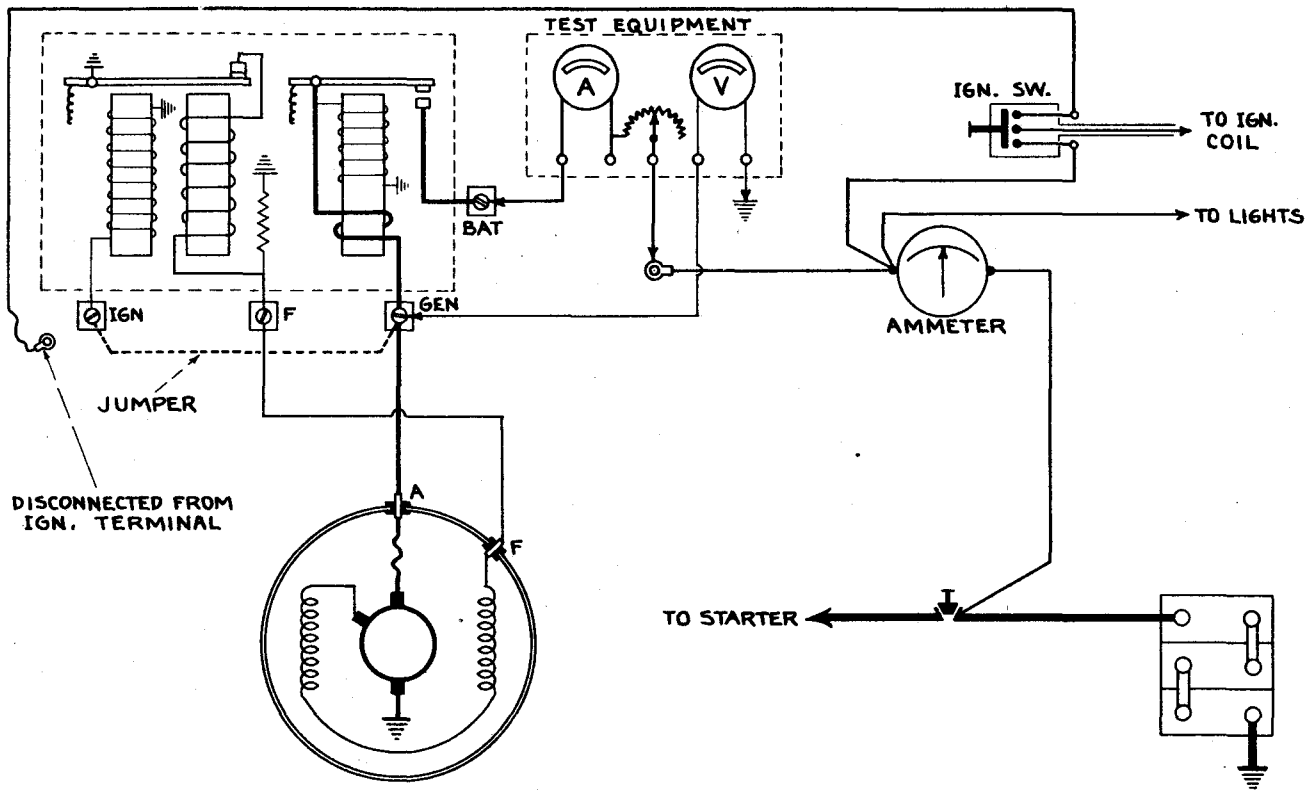

TESTING PROCEDURE - VIBRATING TYPE GENERATOR REGULATOR

Read these instructions carefully and carry out in the order given.

1. Start engine and run until it is warmed up and running smoothly.
2. Ground field terminal on generator, and set engine throttle so that ammeter on the car indicates maximum output.
3. Check voltage across generator and across battery. (Battery voltage must be checked from center to center of the battery posts.) The difference between the two readings should not exceed .75 of a volt. If the difference is greater than .75 of a volt, check generator circuit for high resistance connections.
4. Stop engine and remove ground from generator field terminal.
5. With engine stopped, connect ammeter, rheostat and voltmeter according to instructions given for two-rate generator control. (See diagram.)
6. If control has "Ign" terminal, disconnect regular lead from "Ign" terminal, and connect short jumper from "Ign" terminal to "Gen" terminal as shown in diagram.
7. Set ammeter switch for high scale. Voltmeter switch for low scale. Rheostat control, all resistance out.
8. Start engine and gradually increase speed until ammeter reads maximum output. If battery is fully charged, this may be less than 8 or 10 amps. In such cases, the lights should be turned on to increase the output of the generator or, with the ignition off, the engine should be turned over with the starter for about 10 seconds to partly discharge the battery.
9. With engine running, and ammeter indicating maximum output after the above instructions have been followed, gradually cut in resistance with rheostat until ammeter indicates 8-10 amps.
10. Check voltage indicated on voltmeter. If regulator is not, the voltage should be between 7.45 - 7.55 and 7.55 - 7.85 at room temperature. Average 7.55 - 7.6. (If a manual is available, set according to manual data.)
11. If voltage is too low, increase spring tension on regulator and if too high reduce spring tension.
12. Stop engine before disconnecting test equipment.

CURRENT-VOLTAGE GENERATOR REGULATOR (AUTO-LITE)

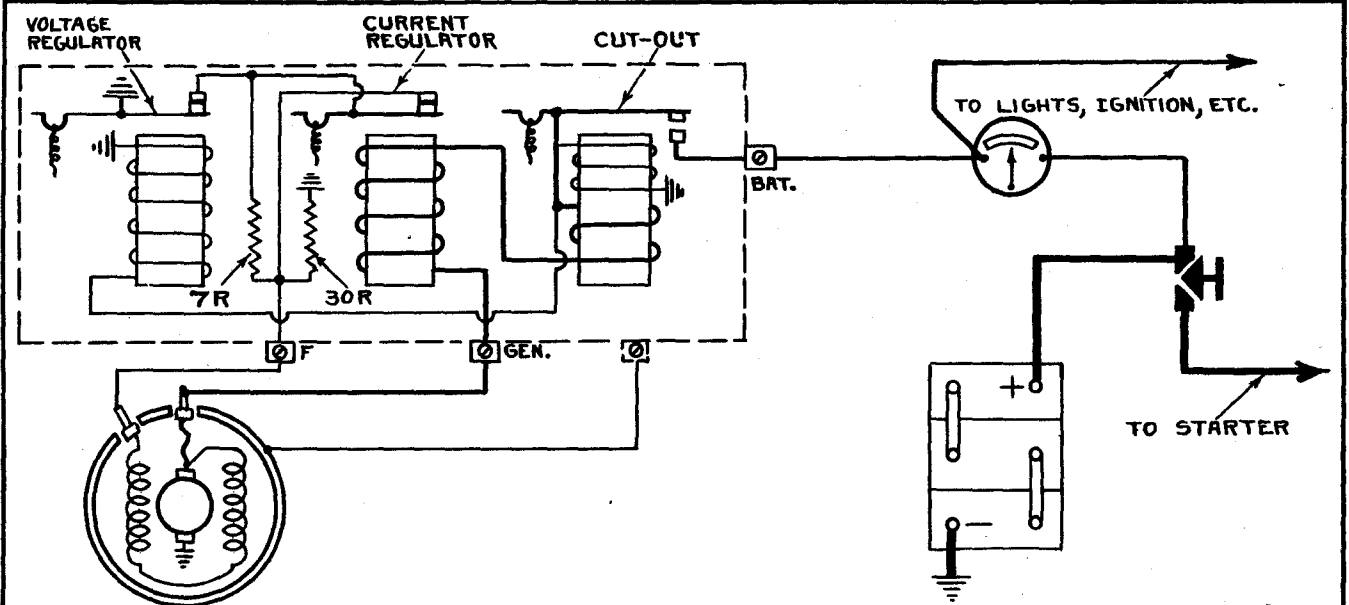

CURRENT-VOLTAGE GENERATOR REGULATOR (DELCO-REMY)

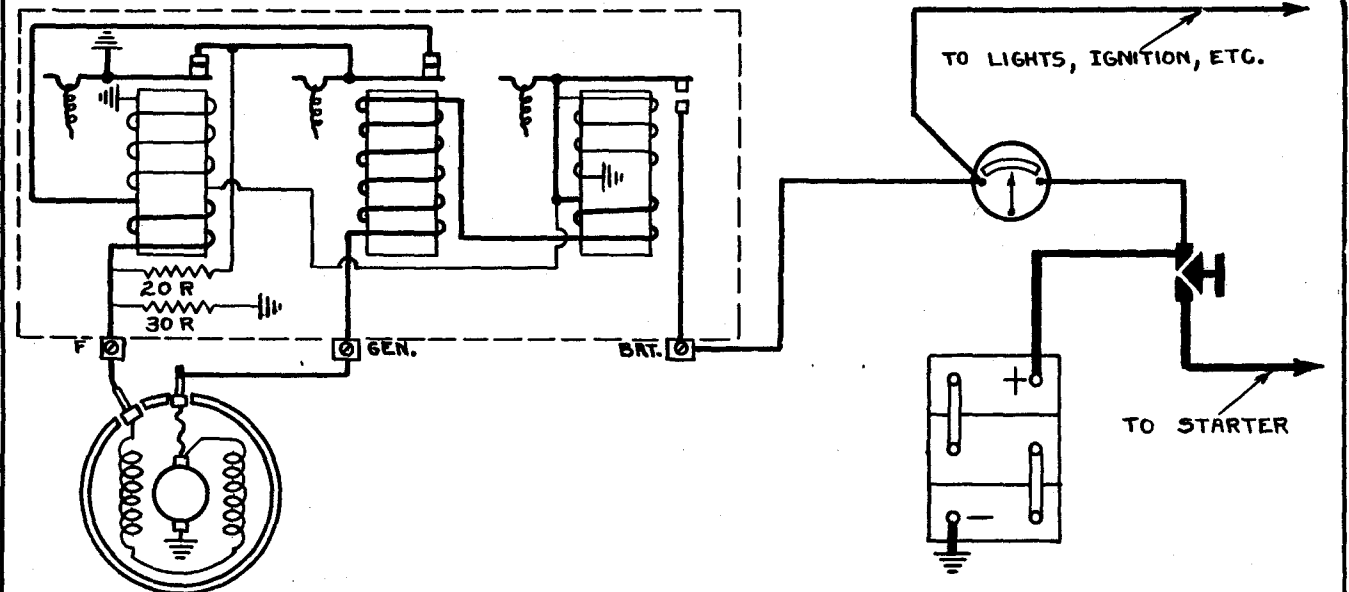

DELCO-REMY CURRENT-VOLTAGE GENERATOR REGULATOR

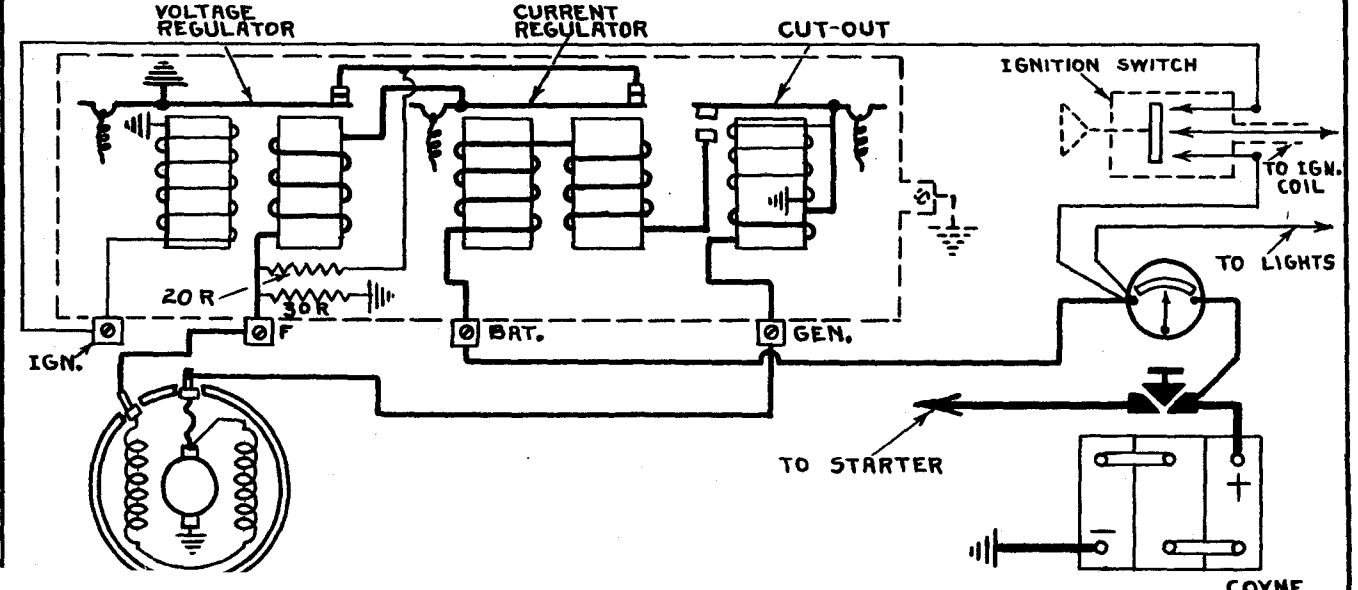

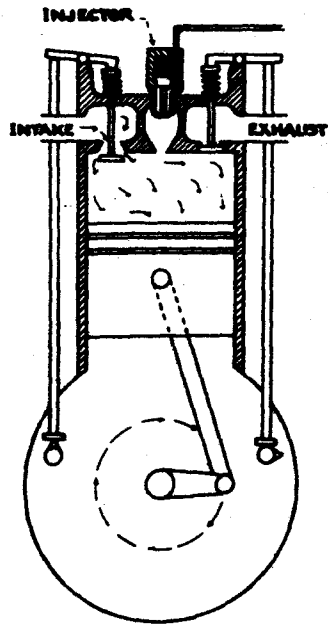

INTAKE STROKE

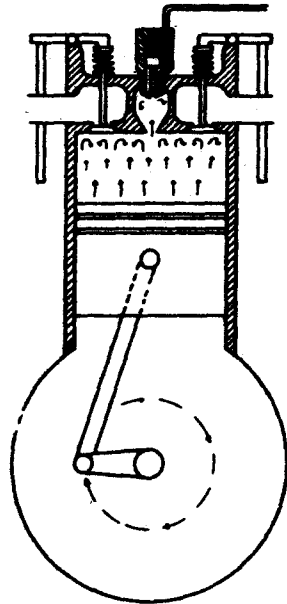

COMPRESSION STROKE

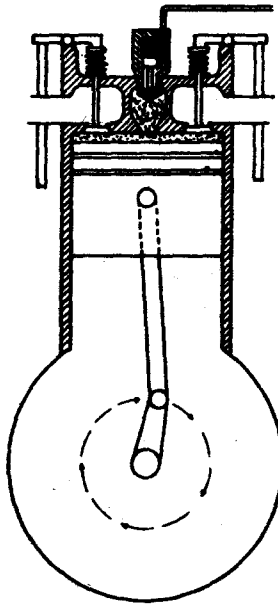

INJECTION AND START OF POWER STROKE

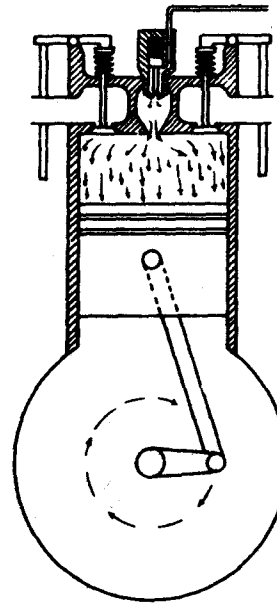

POWER STROKE

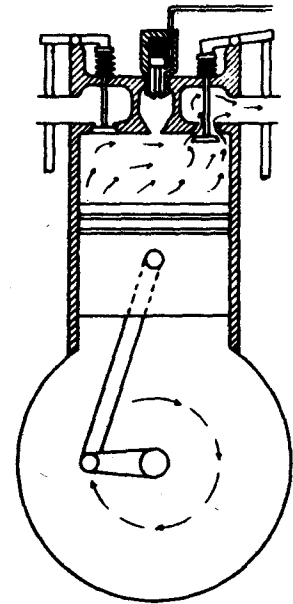

EXHAUST STROKE

4 STROKE CYCLE ENGINE

← STROKE CYCLE SINGLE CYLINDER DIESEL ENGINE

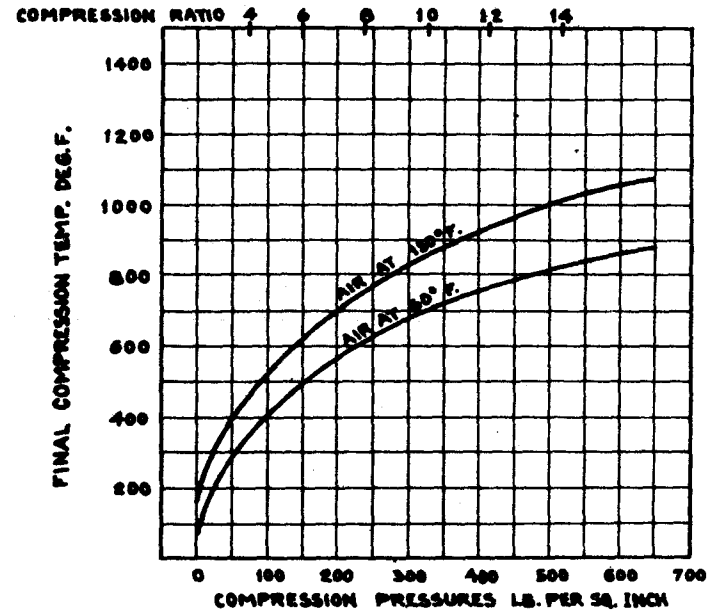
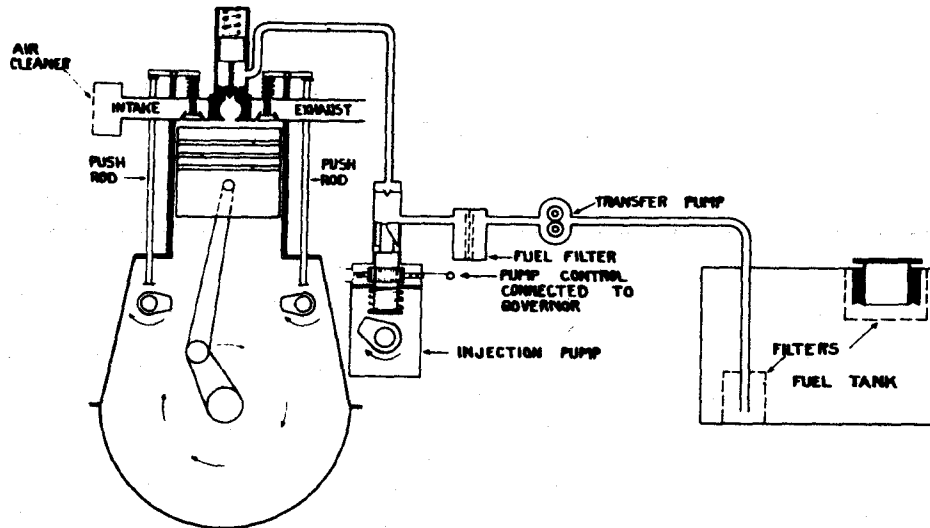

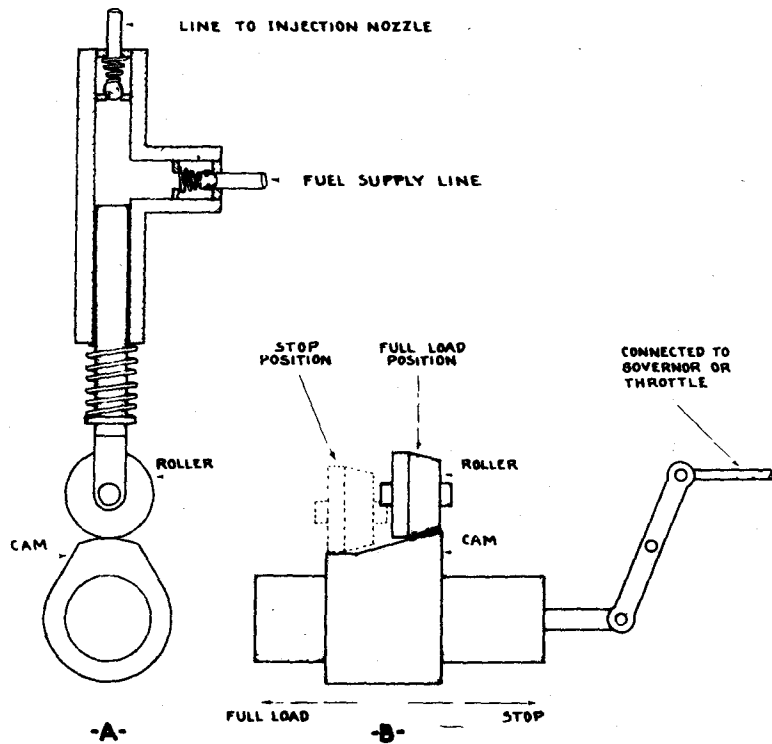

VARIABLE LIFT CAM TYPE FUEL CONTROL

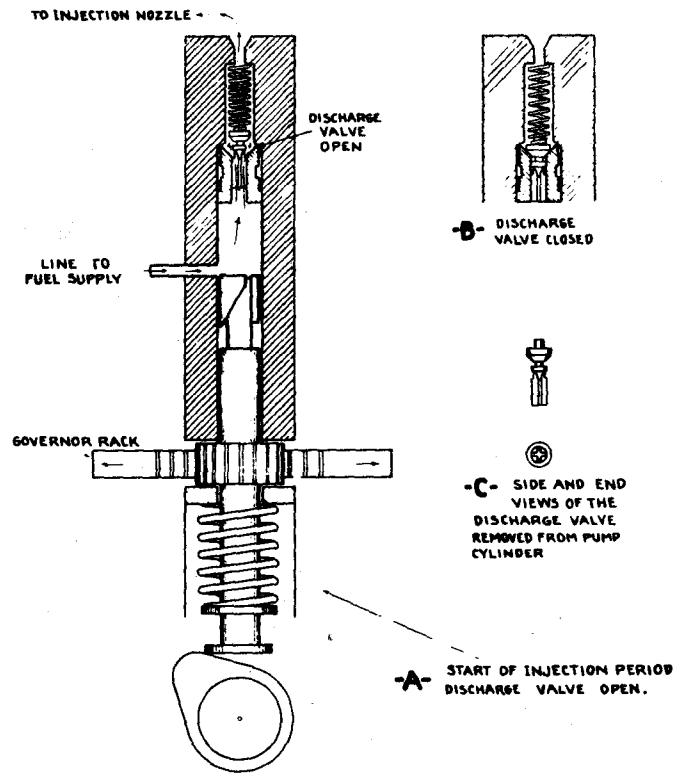

PORT TYPE FUEL CONTROL

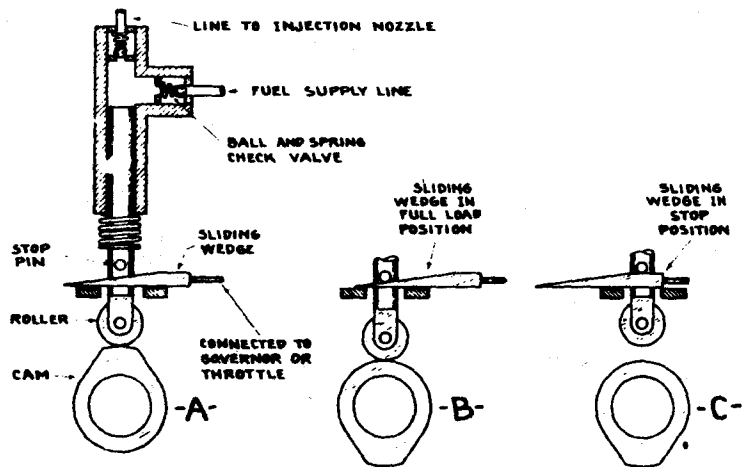

SLIDING STEEL WEDGE TYPE FUEL CONTROL

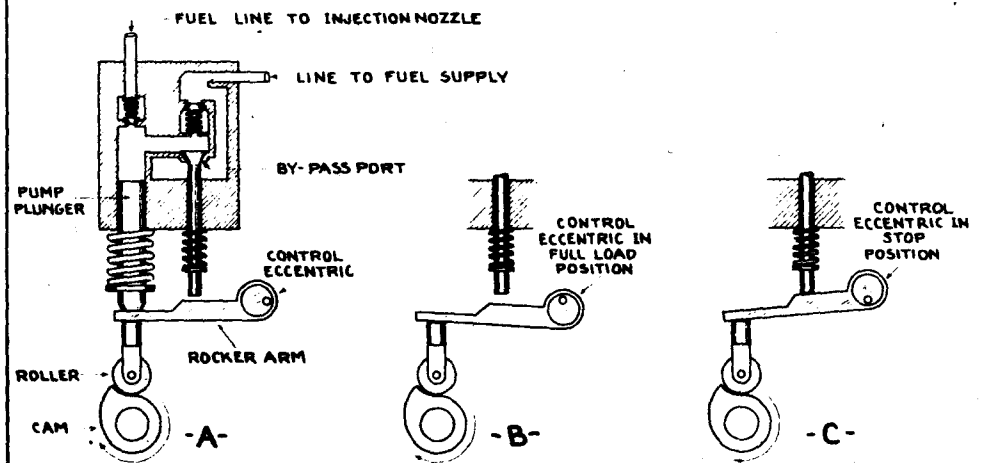

BY-PASS VALVE TYPE FUEL CONTROL

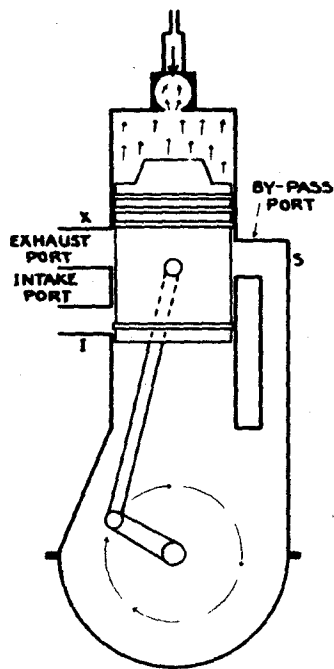

COMPRESSION STROKE
AIR IN CYLINDER BEING
COMPRESSED, VACUUM
BEING DRAWN IN
CRANK CASE.

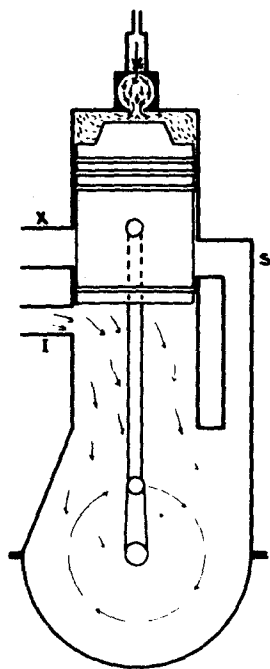

END OF COMPRESSION
STROKE AND START
OF POWER STROKE.

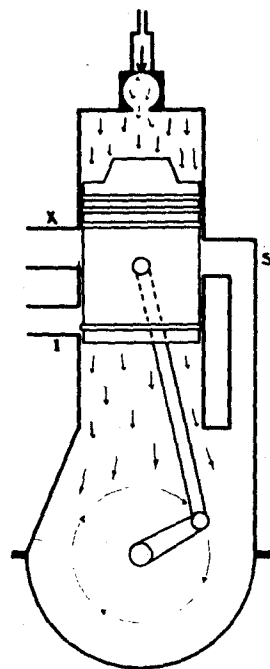

POWER STROKE
AIR IN CRANK CASE
BEING COMPRESSED
BY DOWNWARD MOVE-
MENT OF PISTON.

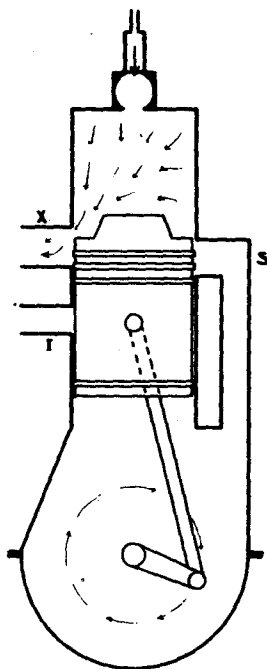

START OF EXHAUST
PERIOD - EXHAUST
PORT STARTING TO
OPEN.

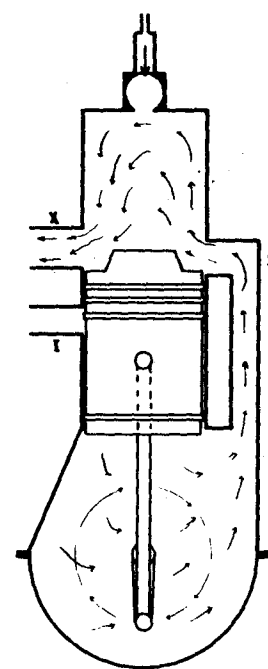

END OF POWER STROKE
BY-PASS PORT OPEN.

2 STROKE CYCLE 3 PORT TYPE ENGINE.

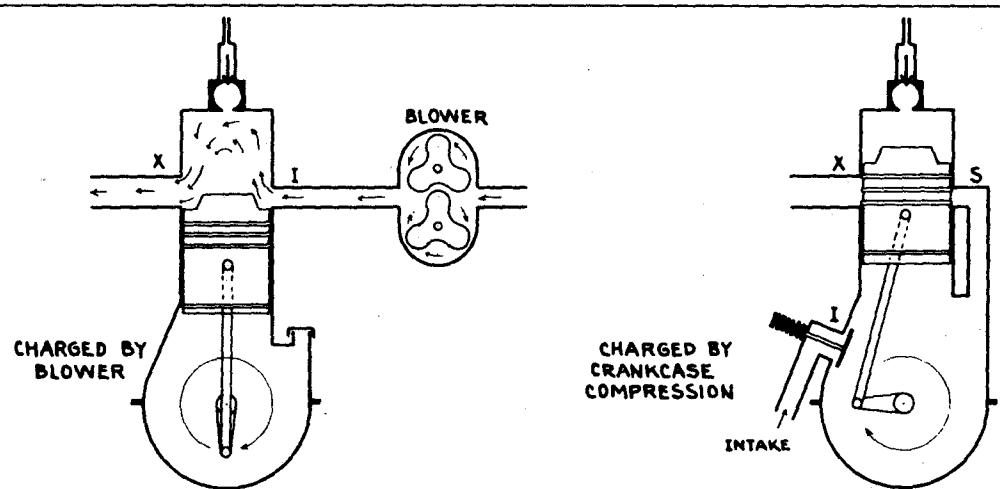
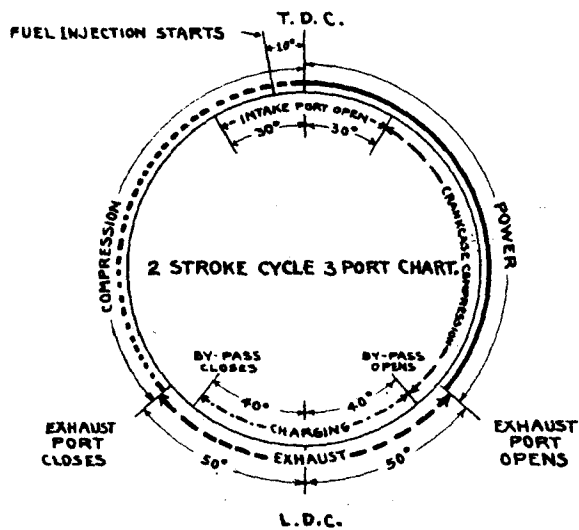

2 STROKE CYCLE 2 PORT ENGINE.

UNIFLOW TYPE 2 STROKE DIESEL ENGINE

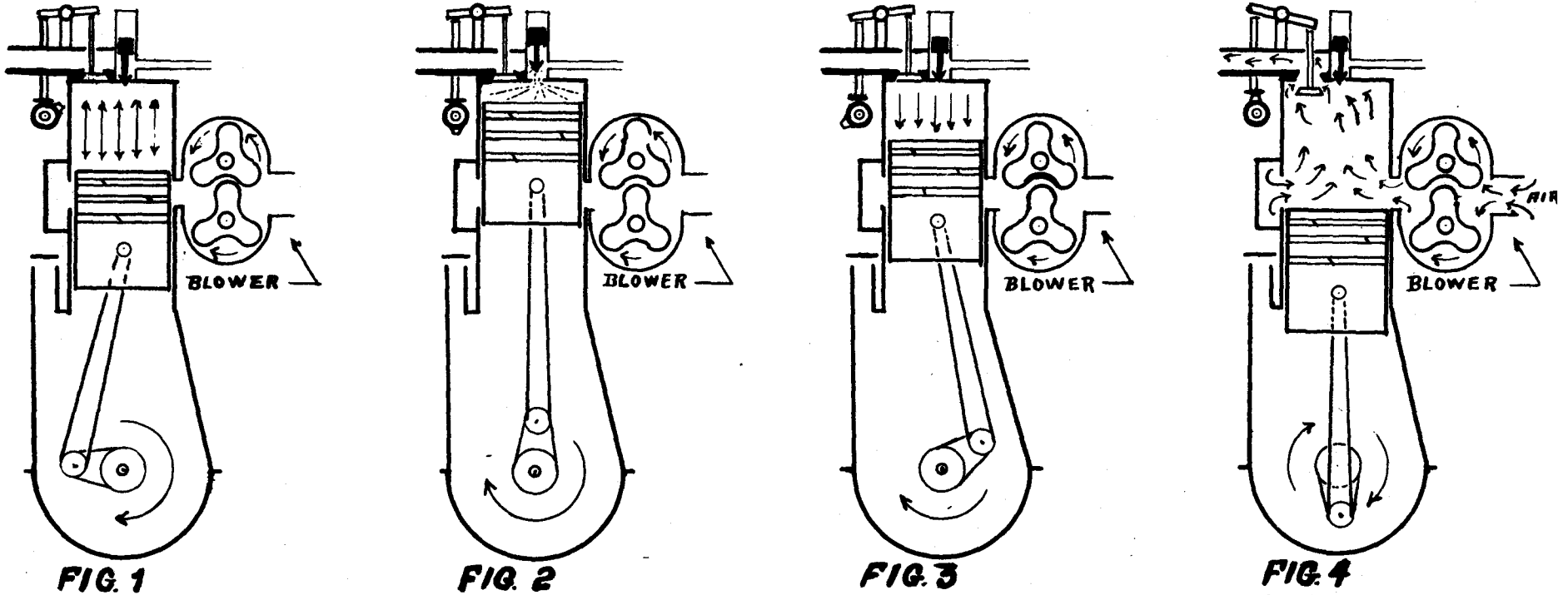

UNIFLOW DIESEL ENGINE CYCLE OF OPERATION

- Fig. 1 Start of compression stroke. Piston moves upward. Inlet air ports and exhaust valve closed.
- Fig. 2 End of compression stroke. Fuel injection starts 14 degrees B.T.D.C. and ends 2 degrees B.T.D.C.
- Fig. 3 Power stroke. Piston forced downward by pressure generated by burning fuel oil and air mixture.
- Fig. 4 Cam operated exhaust valve opens 85½° B.L.D.C. allowing exhaust gases to escape. 48° B.L.D.C. inlet air ports are opened allowing air under pressure to sweep into cylinder, forcing out remaining exhaust gases, and charging cylinder with air. Inlet air ports close 48° after L.D.C. and exhaust valve 55° after L.D.C. One revolution of crank shaft completes the cycle. (See timing chart at right)

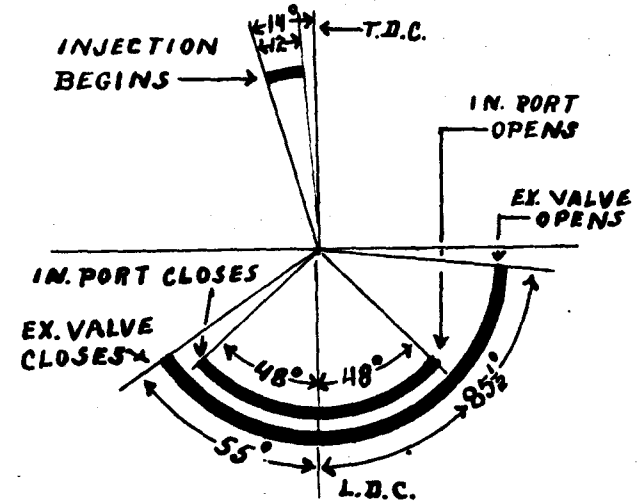

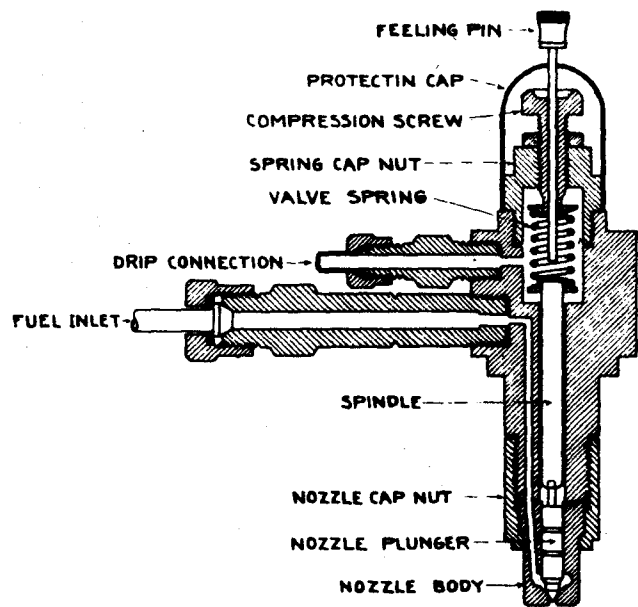

SINGLE HOLE CLOSED TYPE
BOSCH FUEL INJECTION NOZZLE

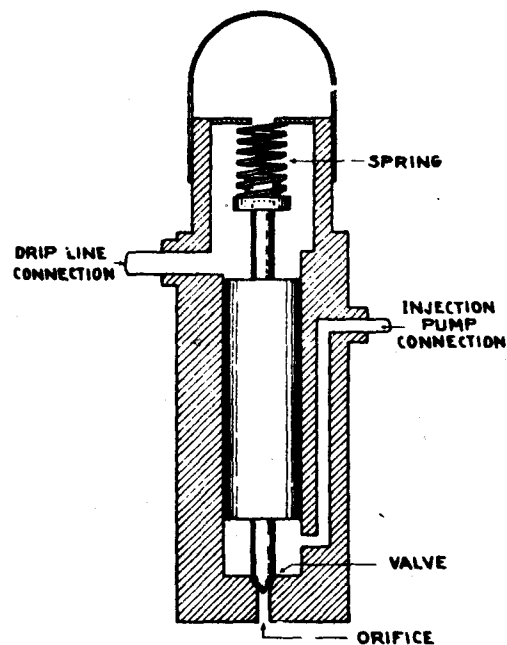

CLOSED TYPE INJECTION NOZZLE

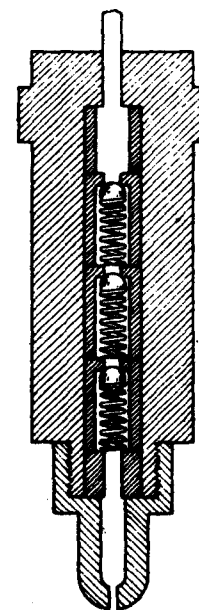

SINGLE ORIFICE
OPEN TYPE INJECTION NOZZLE

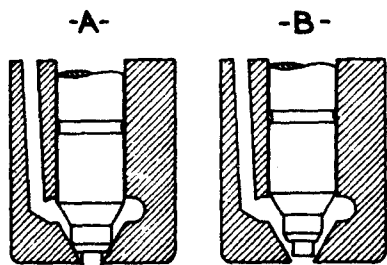

CLOSED

OPEN

PINTLE NOZZLE

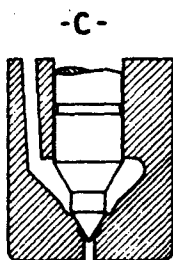

CLOSED

SINGLE HOLE NOZZLE

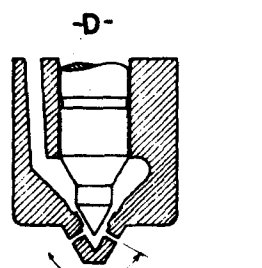

OPEN

MULTI HOLE NOZZLE

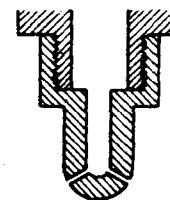

MULTI ORIFICE
OPEN TYPE INJECTION NOZZLE

BATTERY TEST CHARTS AND SCALES

SPECIFIC GRAVITY, VOLTAGE AND CADMIUM TEST CHART.

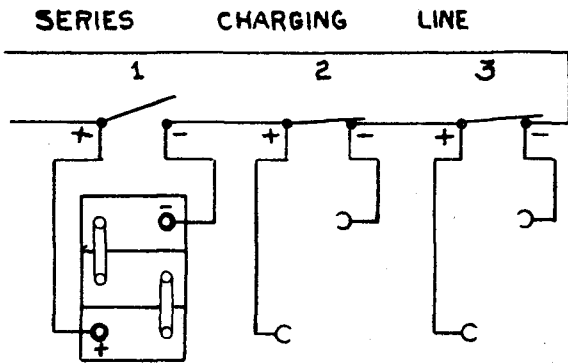

SPECIFIC GRAVITY	E	CADMIUM % CHGED.				REMARKS
		+	-	+	-	

CADMIUM TEST

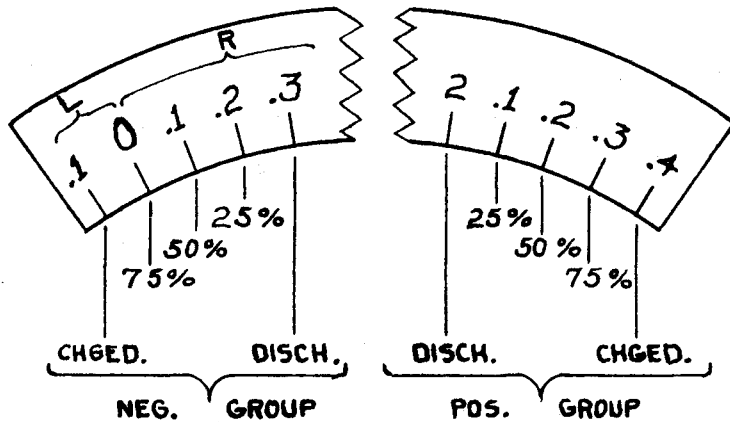
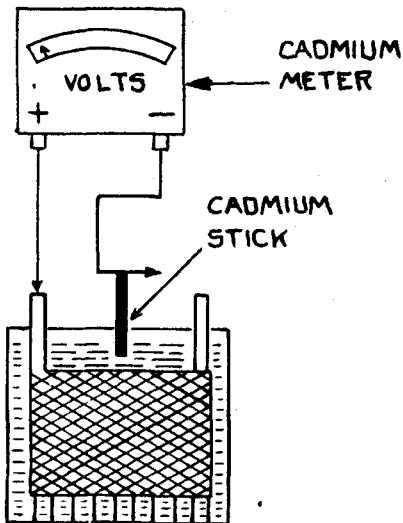

CADMIUM VOLTAGE AND PERCENTAGE SCALE $-.04E$ PER SCALE DIVISION

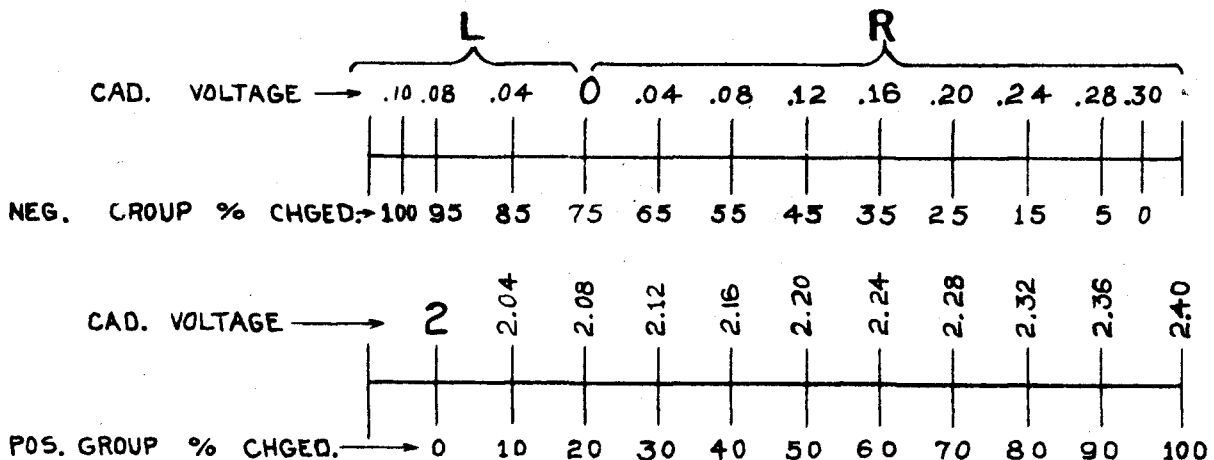

AUTOMOTIVE VOLTAGE TESTS (SEE TEST SHEET AND INSTRUCTIONS)

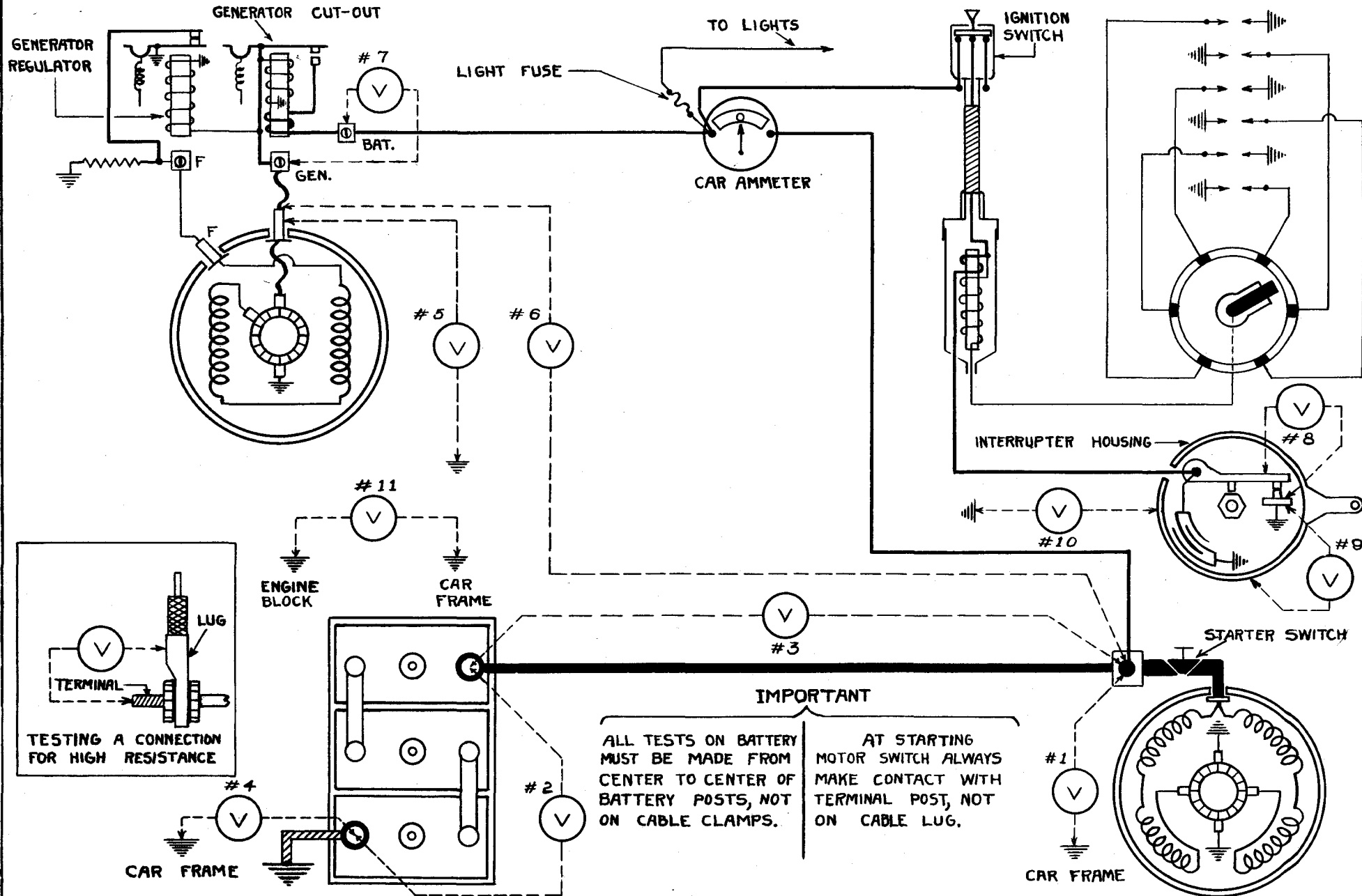

AUTOMOTIVE VOLTAGE TESTS (ENGINE WARM)

Make of Car or Engine _____

TESTING STARTING CIRCUIT & BATTERY:Voltage at V-1 (Starter switch open _____ Volts
(Starter switch closed _____ Volts)Voltage at V-2 (Starter switch open _____ Volts
(Starter switch closed _____ Volts)

Voltage drop at V-3 starter switch closed _____ Volts

Voltage drop at V-4 starter switch closed _____ Volts

Voltage drop at V-11 starter switch closed _____ Volts

TESTING GENERATOR CIRCUIT (Charging at 15-20 Amps.)

If auxiliary generator control is used, ground field terminal. Do not disconnect field lead from generator.

Voltage at V-5 _____ Volts Volt. drop at V-6 _____ Volts

Voltage at V-2 _____ Volts Volt. drop at V-7 _____ Volts

Difference _____ Volts Volt. drop at V-3 _____ Volts

Difference should not exceed .75E. Volt. drop at V-4 _____ Volts

TESTING INTERRUPTER ASSEMBLY:

Interrupter contacts must be CLOSED and ignition switch ON.

Voltage drop at V-8 _____ Volts (Should be zero)

Voltage drop at V-9 _____ Volts (Should be zero)

Voltage drop at V-10 _____ Volts (Should be zero)

STARTING CIRCUIT & BATTERY:Voltage at V-1

Starter switch open, voltage should be 6 volts or better. If less, battery is not fully charged or defective.

Starter switch closed, voltage should be 4.5 or better. If less, and battery is fully charged, check for:

1. Bad connections at battery terminals and battery ground.
2. Corroded starter cable or ground strap.
3. Undersized starter cable or ground strap.
4. Low battery capacity due to undersized battery or shedded plate.
5. Battery overloaded due to defective starter.

Voltage at V-2

Starter switch open, voltage should be 6 volts or better. If less, battery is not fully charged or defective.

Starter switch closed, voltage should be 4.8 volts or better. If less, and battery is charged, check for:

1. Low battery capacity due to undersized battery or shedded plates.

Voltage Drop at V-3 (Starter Switch Closed)

If more than .2 volts, check for:

1. Bad connections at motor or battery end of starter cable.
2. Corroded starter cable.
3. Undersized starter cable.

Voltage Drop at V-4 (Starter Switch Closed)

If more than .1 volts, check for:

1. Bad connections at battery or frame end of ground strap.
2. Corroded ground strap.
3. Undersized ground strap.

Voltage Drop at V-11 (Starter Switch Closed)

Should be zero. If more, engine is not securely grounded to car frame. This applies especially to rubber-mounted engines. Ground with flexible ground strap.

GENERATOR CIRCUIT (Charging at 15-20 Amps.)

If auxiliary generator control is used, ground generator FIELD terminal.

Voltage difference between V-5 and V-2 should not exceed .75 of a volt. If over, make tests V-6, V-7, V-3, and V-4.

Voltage drop at V-6. If over .75 of a volt, check for:

1. High resistance connection between generator and starter switch.
2. Undersized cable between generator and starter switch.
3. Bad cut-out contacts. (Make test V-7.)

Voltage drop at V-7. If over .2 of a volt, cut-out contacts are bad.

Voltage drop at V-3. Should be zero. If more, check for bad connections at both ends of starter cable.

Voltage drop at V-4. Should be zero. If more, check for bad connections at both ends of ground strap.

INTERRUPTER ASSEMBLY:

Interrupter contacts must be CLOSED and ignition switch must be ON.

Voltage drop at V-8. Should be zero. If more, interrupter contacts are rough.

Voltage drop at V-9. Should be zero. If more, grounding pig-tail between grounded contact and interrupter housing is broken.

Voltage drop at V-10. Should be zero. If more,

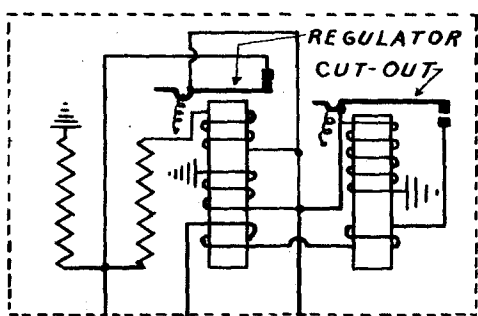

F B G

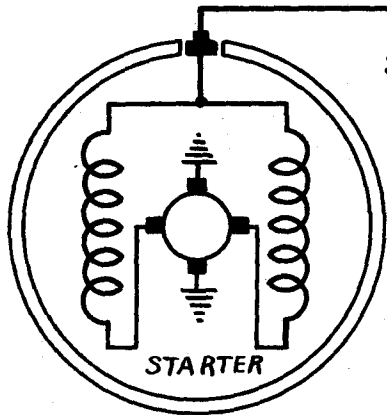
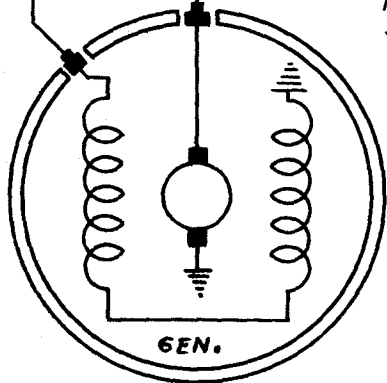

STARTING MOTOR
PUSH BUTTON
SWITCH

STARTING MOTOR SWITCH

TO TEMPERATURE INDICATOR

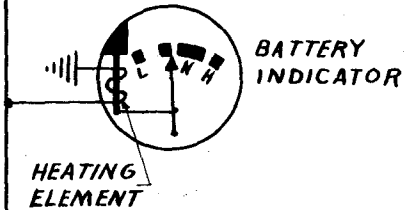

TO LIGHTS

TO HORNS

BALLAST RES.

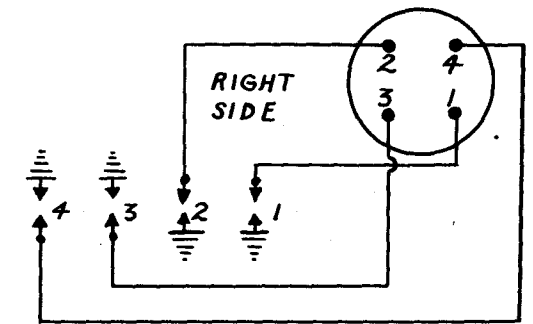
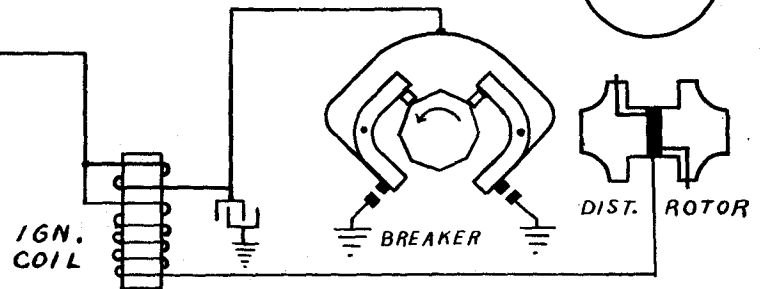
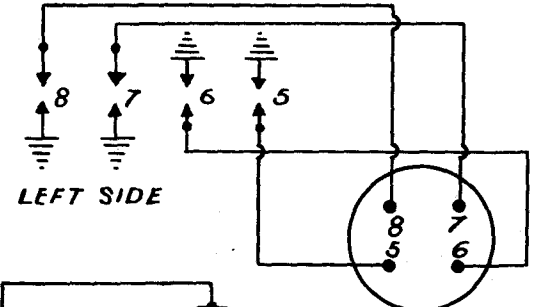
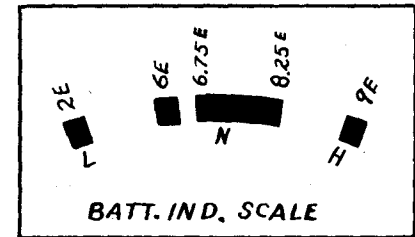

F.O. 1-5-4-8-6-3-7-2

FORD V8

SKETCHES SHOWING VARIOUS DIAL READINGS

DARK NEEDLE INDICATES STEADY HAND -- LIGHT NEEDLE INDICATES MOVING HAND

STEADY NEEDLE
BETWEEN 17-21

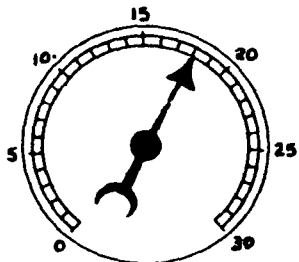

1. Normal motor.

STEADY NEEDLE
BETWEEN 14-16

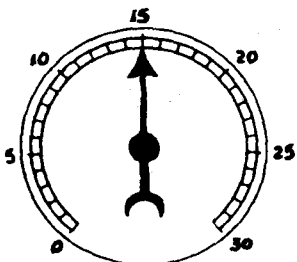

2. Poor rings or oil. Late ignition timing with possibly some needle motion.

STEADY NEEDLE
LOW VACUUM

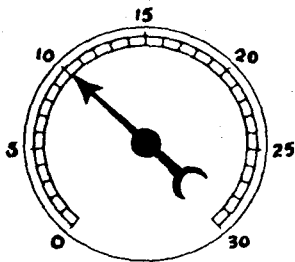

3. Loose valve guides. See also Nos. 2 and 4.

STEADY NEEDLE
LOW VACUUM

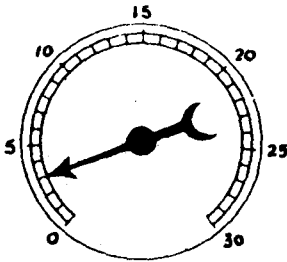

4. Intake manifold or heat riser leak. Also see Nos. 2 and 3.

IRREGULAR DROP
NORMAL VACUUM

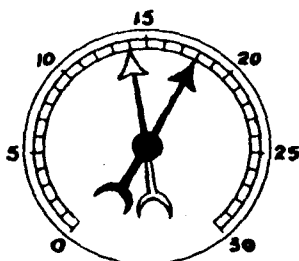

5. Gummy valve stems. Mixture too rich or too lean. Occasional plug miss. Internal carburetor trouble. Also see No. 8.

REGULAR DROP
NORMAL VACUUM

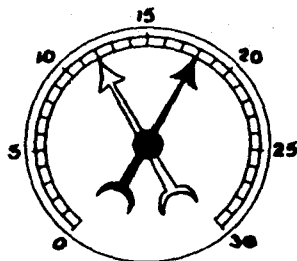

6. Valve held open. Valve chipped, or burnt, or leaks. Warped valve seat. Head gasket leak.

SLOW MOVEMENT
LOW VACUUM

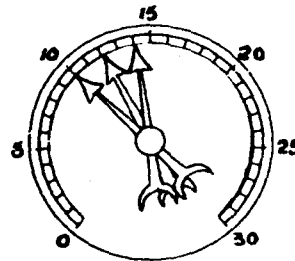

7. Late valve timing. Also see No. 8.

SLOW MOVEMENT
LOW VACUUM

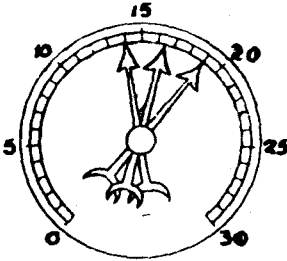

8. Carburetor out of adjustment. Plug gaps too close. Points not synchronized. See also No. 5.

OPERATING MOTOR BY QUICKLY
OPENING AND CLOSING THROTTLE

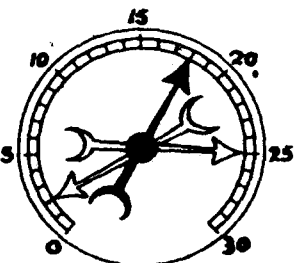

9. Needle drops to 2 when opening throttle, and rebounds to 25 when closing, indicates normal motor.

MOTOR RACING
OR IDLE

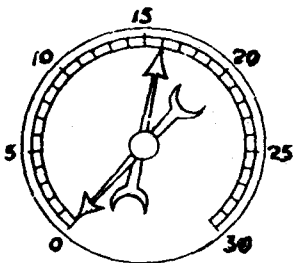

10. Needle drops to 0 when opening throttle, and does not rebound to 25 on closing. Poor rings, pistons, or oil.

MOTOR RACING

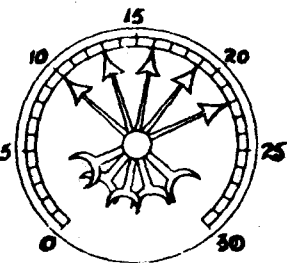

11. Normal reading at start, but gradually drops, indicates choked muffler.

12. Wide variations of needle increasing with motor speed indicate weak, or broken valve springs.

HY-RATE DISCHARGE TEST

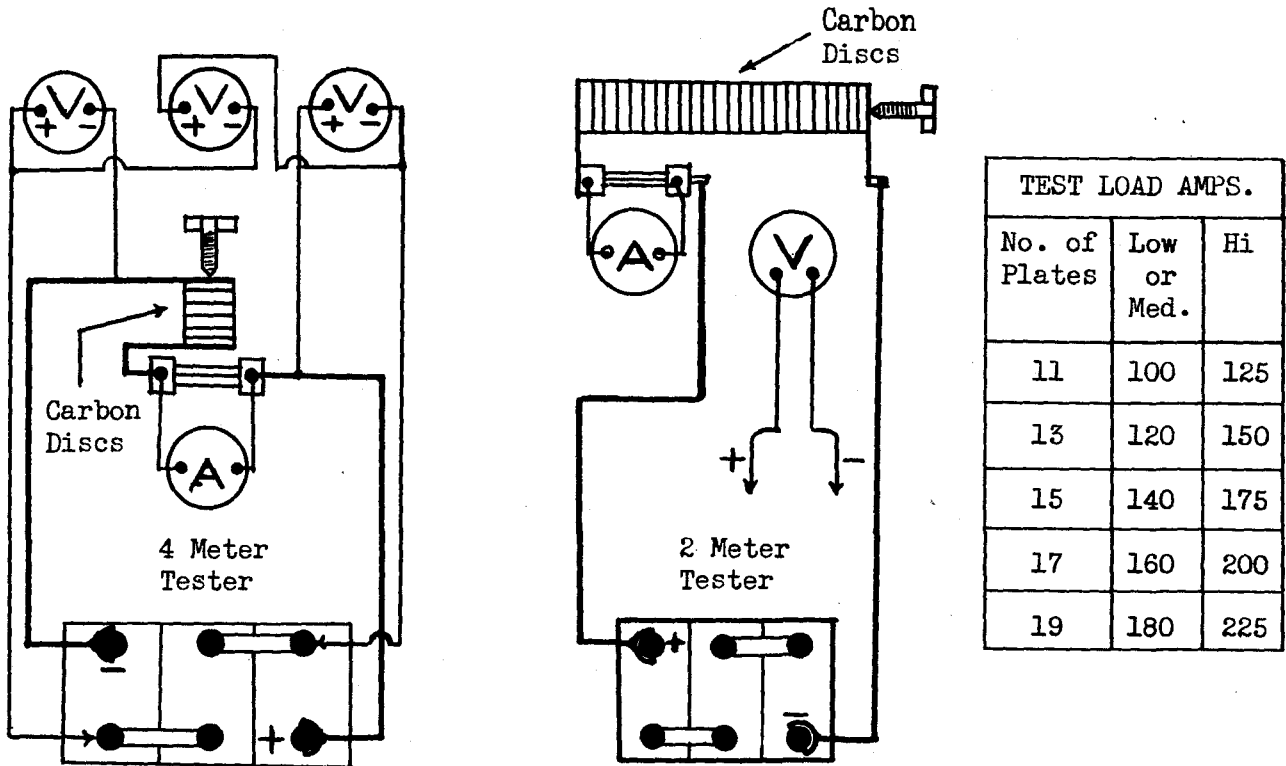

Hy-rate Discharge Test Chart

No. of Plates	Load Amps	Sp. Gr. of Electrolyte	Open Circuit E	Hy-rate test E	Condition of Cells

CONDITION OF BATTERY

If all cell voltages are equal within .15 of a volt and above 1.8 volts battery is charged.

If all cell voltages are equal within .15 of a volt, but below 1.8 volts battery is discharged.

If cell voltages are unequal by more than .15 of a volt or if all voltages are less than .6 of a volt, battery is defective.

PLATES PER CELL

	A	B	C
Plate thickness	$\frac{1}{8}$	$\frac{3}{32}$	$\frac{1}{16}$
9" Case	11	13	15
10 1/4" Case	13	15	17
11 3/4" Case	15	17	19
13 1/8" Case	17	19	21

NOTE

Thin wall cases may contain 2 more plates than number given above.

RADIO TRANSMISSION AND RECEPTION.

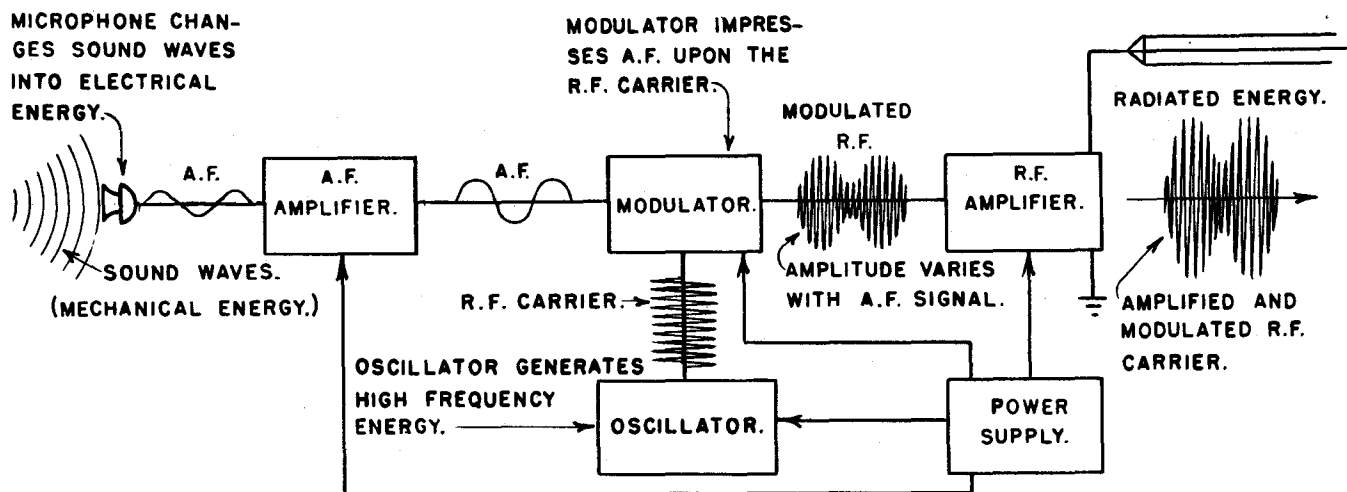

A device designed for the transmission of voice or music by radio must be provided with:

1. Some means whereby air pressure variations (sound) may be changed into equivalent electrical impulses. This is the function of the microphone.
2. A section designed to generate the radio frequency A.C. carrier energy. This is the function of the oscillator.
3. An arrangement which will impress the audio frequency energy upon the R.F. carrier. This is the function of the modulator.
4. Some device that will cause the modulated energy to be radiated into space. This is the function of the transmitting antenna.
5. A source of electrical energy; that is, a power supply.

If a relatively large amount of power is to be radiated, amplifying stages in both the R.F. and the A.F. sections will be required.

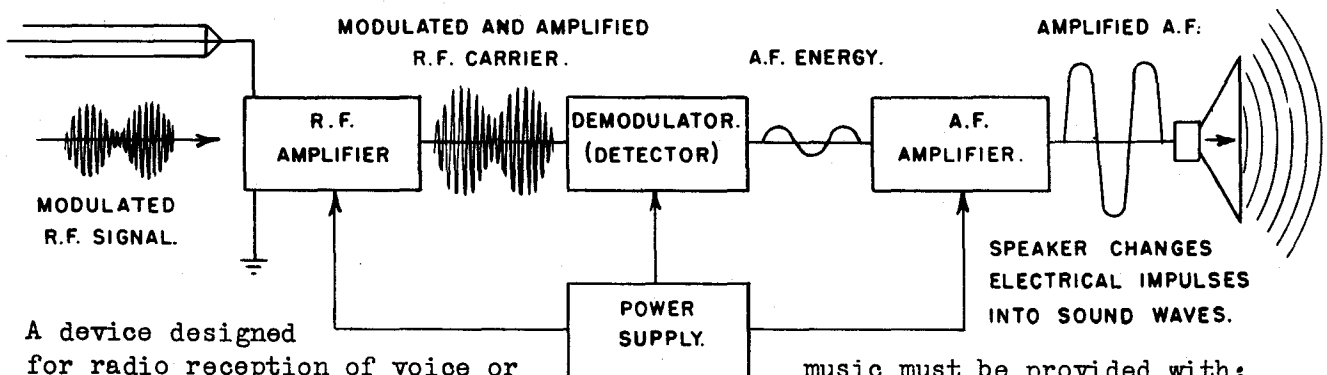

A device designed for radio reception of voice or music must be provided with:

1. A means of picking up the desired transmitted energy. This is the function of the receiving antenna, and tunable resonant circuits.
2. Some means of recovering the A.F. impulses from the modulated R.F. carrier. This is the function of the demodulator.
3. A device for changing electrical impulses into sound. This is the function of the loud speaker or headphones.
4. A source of electrical energy; that is, a power supply.

DEMODULATION BY DIODES.

After the modulated R.F. signal has been picked up by the antenna and amplified by the R.F. stages in the receiver, it becomes necessary to recover the A.F. signal from the R.F. carrier. The stage in the receiver designed to accomplish this is called the demodulator stage, or the detector stage.

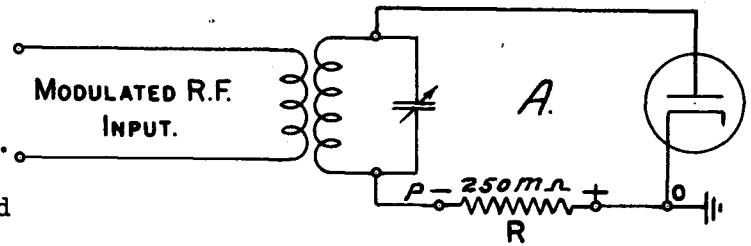

Basically, demodulation consists of two steps:

1. Rectification (either partial or total) of the modulated R.F. input.
2. Filtering of the R.F. variations from the rectified modulated output.

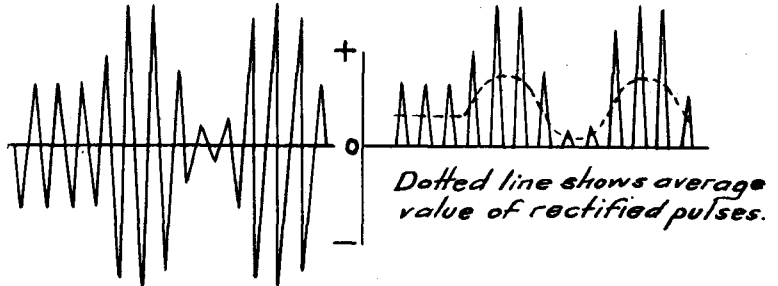

Reference point is 0 on all sketches.

The type of tube most widely used for demodulation purposes is the diode. This tube serves as a rectifier to remove the negative half of the modulated carrier. Although not as sensitive as triode demodulators, the diode handles relatively strong signals (10 to 30 volts) well and produces little distortion.

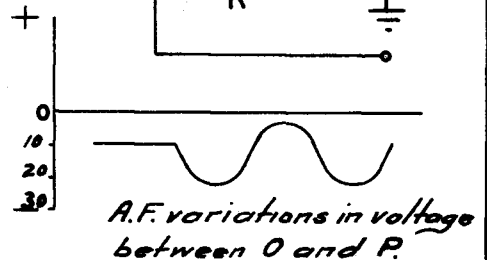
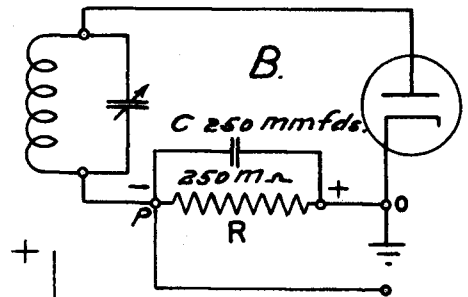

As the rectified current flows through the diode load resistor R, it produces a voltage drop that drives the point P negative with respect to O. By connecting a condenser across R as shown in Fig. B, the R.F. pulsations are filtered out.

The unmodulated R.F. carrier produces a steady negative voltage at point P, but when modulated energy is passed through R the potential at point P follows the A.F. variations in the modulated input. This action produces between O and P a voltage that varies in proportion to the amplitude of the modulation envelope. In this manner, the original A.F. signal is recovered.

By-passing of the A.F. signal across R is prevented by making the capacity of C so small that it has a high reactance to A.F. The much higher frequency R.F. currents are readily bypassed around the diode load resistor R.

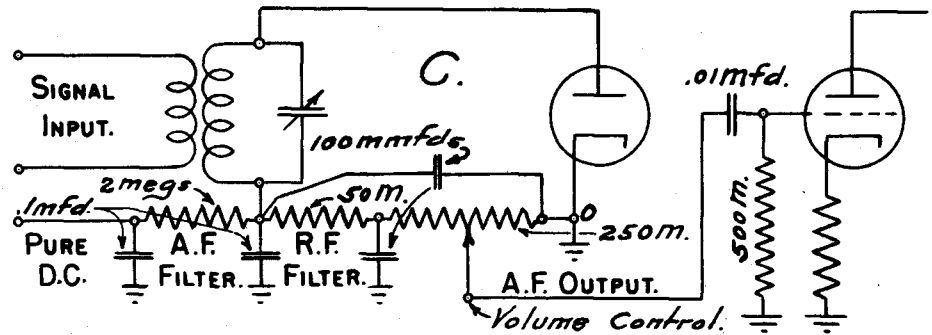





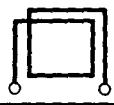

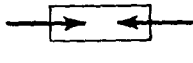

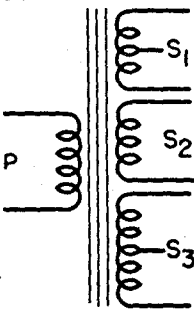

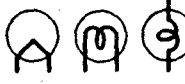



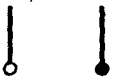

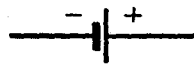

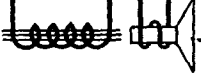

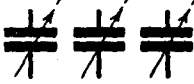
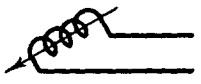



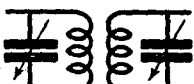

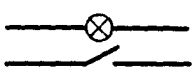
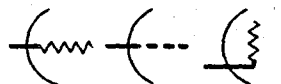







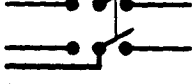

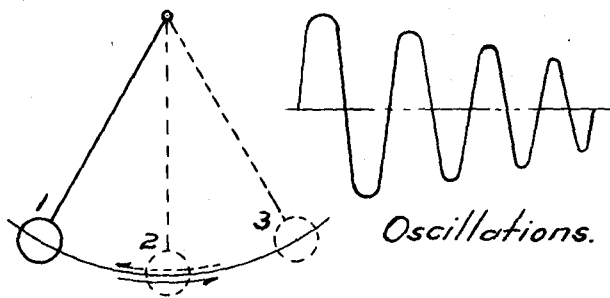

Diagram C shows the same basic circuit as A and B with the addition of a volume control and some additional filtering. Note how the voltage between O and P is applied to the grid circuit of the following A.F. amplifier tube. The A.F. filter is employed to remove the A.F. variations from the diode output so that a steady D.C. voltage, proportional to the carrier strength, may be obtained for purposes of automatic volume control.

SCHEMATIC SYMBOLS USED IN RADIO

 <p>ANTENNA (AERIAL)</p>	 <p>IRON-CORE CHOKE COIL</p>	 <p>SWITCH (ROTARY OR SELECTOR)</p>
 <p>GROUND (OR CHASSIS CONNECTION)</p>	 <p>R F TRANSFORMER (AIR CORE)</p>	 <p>CRYSTAL DETECTOR</p>
 <p>LOOP AERIAL (USUALLY BUILT INTO CABINET OF RECEIVER)</p>	 <p>A.F TRANSFORMER (IRON CORE)</p>	 <p>LIGHTNING ARRESTER</p>
 <p>CONNECTION</p>	 <p>POWER TRANSFORMER P: 115-VOLT PRIMARY S₁: CENTER-TAPPED SECONDARY FOR FILAMENTS OF SIGNAL CIRCUIT TUBES S₂: SECONDARY WINDING FOR RECTIFIER TUBE FILAMENT S₃: CENTER-TAPPED HIGH-VOLTAGE SECONDARY WINDING</p>	 <p>FUSE</p>
 <p>NO CONNECTION</p>		 <p>PILOT LAMP</p>
 <p>NO CONNECTION (WHEN CONNECTIONS ARE INDICATED BY DOTS)</p>		 <p>HEADPHONES</p>
 <p>CONNECTION (WHEN NO-CONNECTION CROSS-OVERS ARE INDICATED BY HALF- CIRCLES)</p>		 <p>FIXED CONDENSER (MICA OR PAPER)</p>
 <p>TERMINAL</p>	 <p>FIXED CONDENSER (ELECTROLYTIC)</p>	 <p>LOUDSPEAKER, P.M. DYNAMIC</p>
 <p>ONE CELL OR "A" BATTERY</p>	 <p>VARIABLE CONDENSER ROTOR PLATES</p>	 <p>LOUDSPEAKER, ELECTRODYNAMIC</p>
 <p>MULTI-CELL OR "B" BATTERY</p>	 <p>GANG TUNING CONDENSER</p>	 <p>PHONO PICK-UP</p>
 <p>RESISTOR</p>	 <p>TRIMMER AND PADDER CONDENSER</p>	 <p>FILAMENT</p>
 <p>POTENTIOMETER</p>	 <p>I.F. TRANSFORMER (DOUBLE-TUNED)</p>	 <p>CATHODE</p>
 <p>TAPPED RESISTOR OR VOLTAGE DIVIDER</p>	 <p>POWER SWITCH (S.P.S.T.)</p>	 <p>GRID</p>
 <p>RHEOSTAT</p>	 <p>SWITCH (S.P.D.T.)</p>	 <p>PLATE</p>
 <p>AIR-CORE CHOKE COIL</p>	 <p>SWITCH (D.P.S.T.)</p>	 <p>3-ELEMENT VACUUM TUBE</p>
 <p>AIR-CORE CHOKE COIL</p>	 <p>SWITCH (D.P.D.T.)</p>	 <p>ALIGNING KEY OF OCTAL BASE</p>

FUNDAMENTALS OF RADIO.



- 1- Energy stored in weight due to position.
- 2- Stored energy all converted to energy of motion.
- 3- Energy of motion all converted to energy of position.

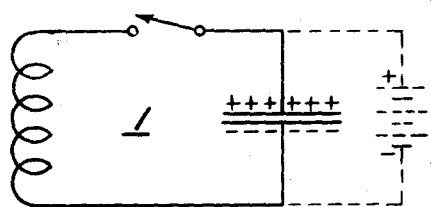

1-Electrostatic energy stored in condenser.

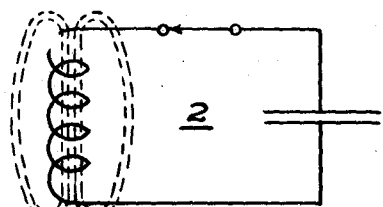

2-Electrostatic energy changed to electromagnetic energy.

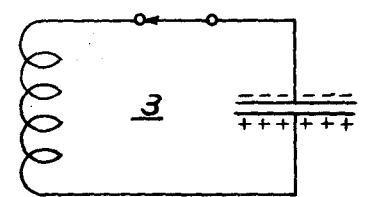

3-Electromagnetic to electrostatic.

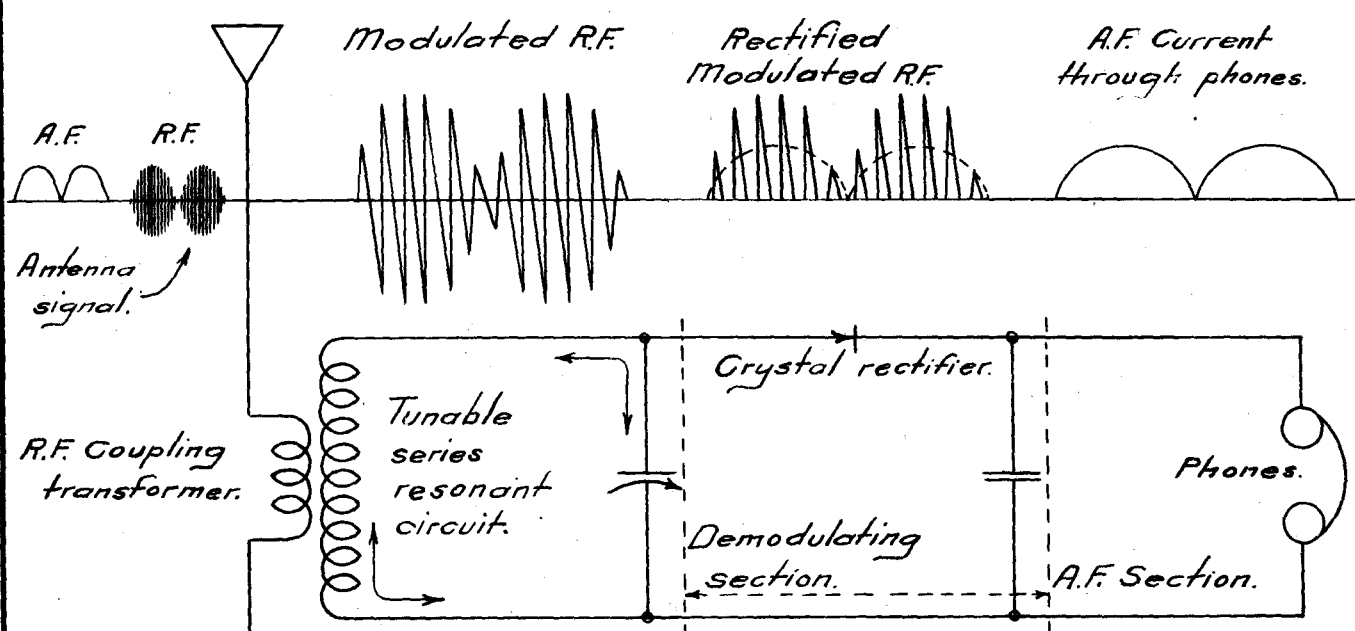
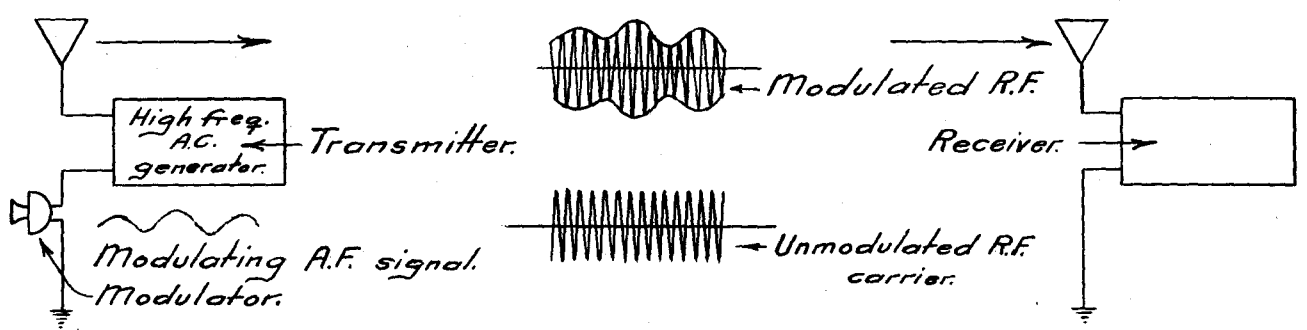

Note that the resonant circuit provides amplification as well as selection. The resonant circuit in a broadcast receiver should respond equally to a band of frequencies 10 K.C. wide.

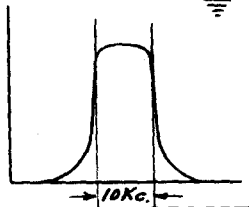

CONDENSER ACTION.

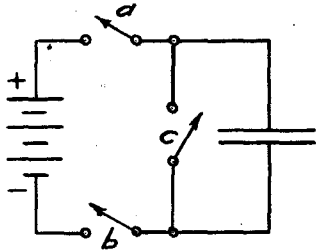

When the mechanical pressure on either side of the diaphragm or the electrical pressure on either side of the dielectric is the same, both diaphragm and dielectric are in an unstressed condition. Under such circumstances no energy can be stored in either system.

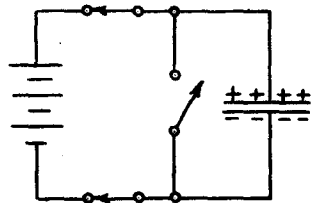
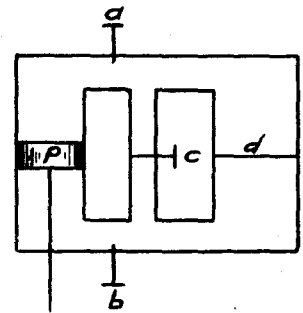

When the piston is moved up pressure at X increases, creating difference in pressure that stresses the diaphragm. When a difference in electrical pressure is applied to the condenser the dielectric is similarly stressed. Both systems now store energy.

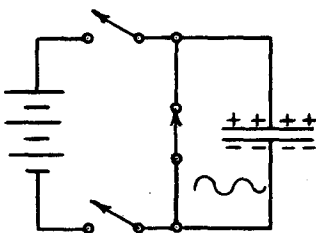
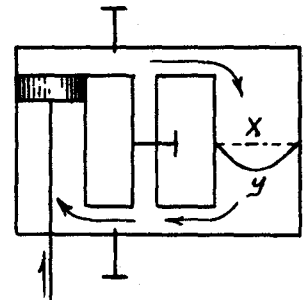

Providing a path through C relieves mechanical stress in the diaphragm and the electrical stress in the dielectric. The momentum of the liquid causes the diaphragm to reverse its position; thus in both systems oscillations are set up that finally reduce the stored energy to zero.

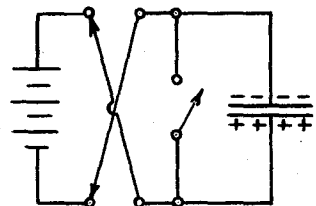
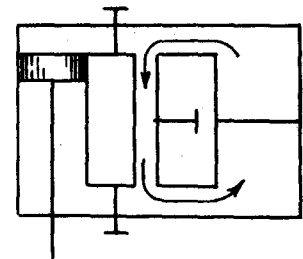

With the difference in pressure reversed, the diaphragm is stressed in the opposite direction. The stress in the dielectric is also reversed and the condenser is charged with the opposite polarity. Both systems again store energy.

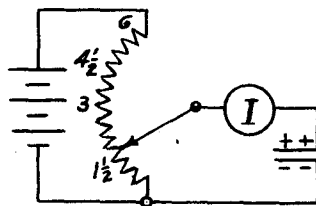
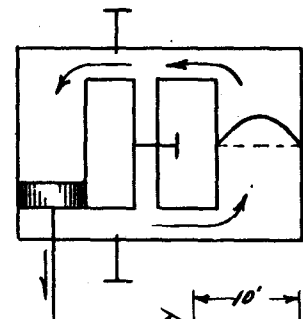

By moving the arm up and down the condenser is caused to charge and discharge repeatedly. Note that the condenser input is pulsating DC, where-as the condenser circuit is A C; thus current appears to flow through the condenser although it really pulsates in and out of it.

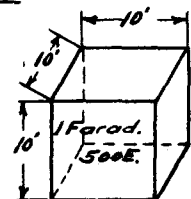

Electrical capacity depends upon:

1. Area of the dielectric and plates
2. Thinness of the dielectric
3. Dielectric material

Hydraulic capacity depends upon:

1. Area of diaphragm and cylinder
2. Thinness of the diaphragm
3. Diaphragm material

Capacity of electrical condensers is measured in Farads. When a condenser has one Farad capacity, it will absorb one coulomb of electricity when one volt is applied. The practical unit of capacity is the microfarad.

L.

INDUCTANCE.

L.

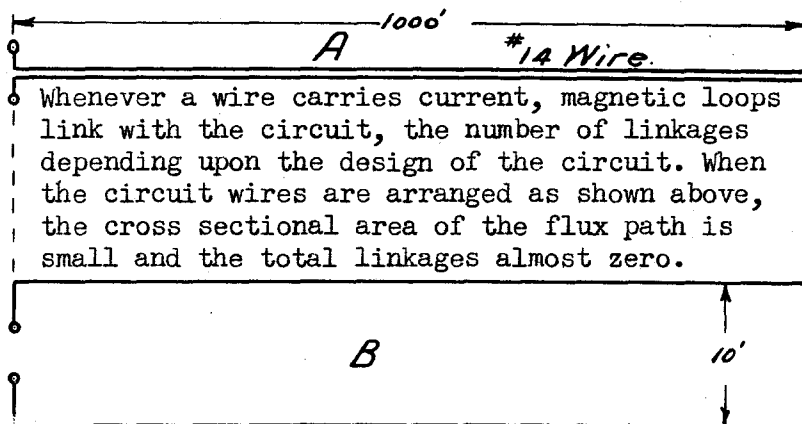

Whenever a wire carries current, magnetic loops link with the circuit, the number of linkages depending upon the design of the circuit. When the circuit wires are arranged as shown above, the cross sectional area of the flux path is small and the total linkages almost zero.

In B the wires are more widely spaced, the area enclosed by the circuit being greatly increased. This circuit will produce many more flux linkages per ampere than A.

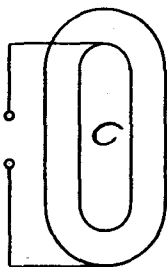

In C the same wire used in A and B is wound in the form of a coil. Per ampere, this circuit produces many more linkages than B because increasing the turns increases the total flux; furthermore, the increased flux now links with the circuit in increased number of times as each line of flux tends to link with all turns of the coil: thus the linkages between circuit and flux are greatly increased.

D is the same coil as C except that its shape has been changed in order to make the cross section of the flux path a maximum. This coil will produce more flux per amp. than C; therefore the flux linkages set up for a given current will be greater in D even though both coils have the same number of turns and use the same size wire. Since all circuits shown here use the same size and length of wire, the ability to produce flux linkages evidently depends upon the shape of the circuit.

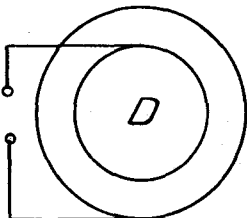

In E an iron core has been added to provide an easier path for the flux; this results in a tremendous increase in the flux and the number of linkages per ampere. Consideration of the several circuits shown indicates that the ability of a circuit to produce linkages depends upon the number of turns in the circuit, the area of the flux path, and the character of the flux path. When a circuit will produce 100,000,000 linkages for each ampere of current flowing in it, it has an inductance of one Henry. Whenever the current in an inductive circuit changes, the flux changes; this varying flux cuts the wires and induces in the circuit a voltage that opposes the change. In a circuit that has an inductance of one Henry, current changing at the rate of one ampere per second will produce in it a self-induced voltage of one volt.

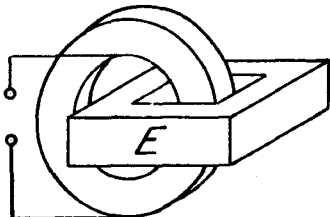

When the current flowing in a circuit does not vary, there is no inductive effect. Inductance may be very important, however, with regard to the opposition that it develops in circuits carrying varying D.C. or A.C. In circuits of this type, the effects of inductance may be much more important than those produced by the ohmic resistance of the conductors.

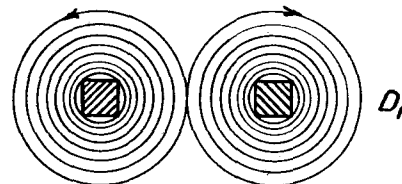
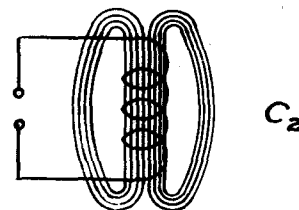
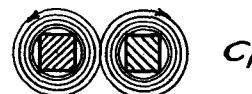
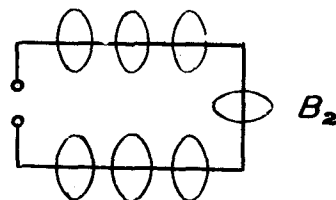
oo A₁

X_L

REACTANCE.

X_C

In a circuit carrying unvarying current, the only opposition to current flow is the resistance of the conductors. In a circuit carrying varying D.C. or A.C. other kinds of opposition, in the form of opposing voltages, may appear. These voltages may be responsible for the greater part of the opposition offered to current flow. For example, if a current such as A were forced through a coil of one Henry inductance the average value of the self induced voltage would be 240 volts; for current B, 480 volts,

These high values of voltage result from the high rate of current change in amperes per second. Curve A represents a rate of change of 240 amperes per sec; B, 480 amps per sec. Curve C, which depicts a pulsating D.C. current, would create the same self-induced voltage in a circuit of one Henry inductance as curve B.

INDUCTIVE REACTANCE: The counter voltage produced by a continually varying current flowing in an inductive circuit is termed inductive reactance. Its symbol is X_L and its value is given in ohms for mathematical convenience.

The relative between inductance (L) and inductive reactance (X_L) is given by the formula:

$$X_L = 2\pi fL$$

Note that X_L is proportional to the frequency, Doubling the frequency (f) will double the reactance because it doubles the rate of current change in amperes per second.

CAPACITIVE REACTANCE: If a current of the character depicted by these curves is applied to a condenser, the condenser will charge and discharge repeatedly, the number of charges per second depending upon the frequency. As these actions are taking place, the condenser develops a counter voltage that limits current flow. The opposition effect offered to the flow of a varying current by a condenser is called capacitive reactance. Its symbol is X_C and its value is given in ohms. X_C depends upon the condenser capacity in Farads (C) and the frequency (f) of the current as shown by the formula:

$$X_C = \frac{1}{2\pi fC}$$

Note that the greater the capacity of the condenser, and the higher the frequency, the lower will be the X_C .

Inductive and capacitive effects may be of considerable importance in D.C. circuits carrying varying currents such as those shown in curves C and D; for such a current may be regarded as consisting of two parts or components, the unvarying D.C. component, (shown by the dotted line) and the varying or A.C. component (shown by the curves). In many cases the value of the A.C. component is of more importance in determining the character of the circuit reactions than is the D.C. component. This is particularly true in radio circuits where the A.C. component may represent the signal voltage that the receiver is designed to select and amplify.

Sketch E shows how a counter voltage may be used to diminish current in a circuit, and why it is mathematically permissible to regard such an opposing voltage as a resistance.

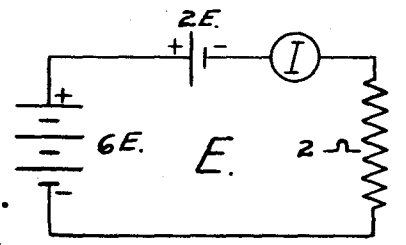
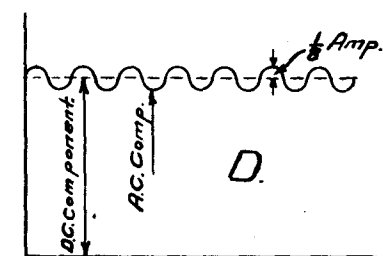
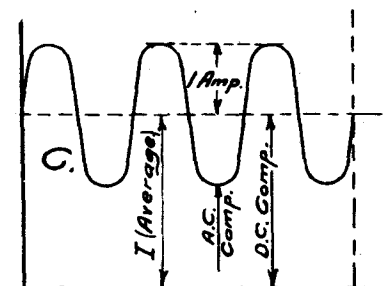
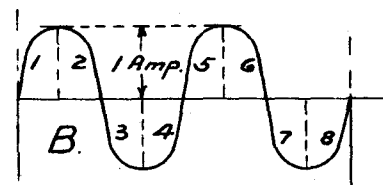
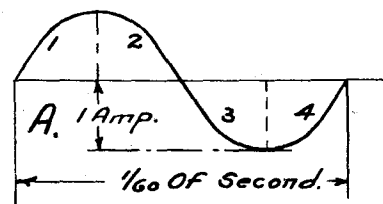

R AND L IN SERIES

If the arithmetical sum of E_R and E_L is compared with the applied line voltage. It will be found that the former is considerably greater than the latter; this is due to the fact that the voltage E_R and the voltage E_L do not reach their maximum values at the same instant. As shown by the curves and the vector diagrams these voltages are actually "out of phase" with each other by one-quarter of a cycle or 90 electrical degrees. It is because of this phase difference that the opposition effects encountered in the A.C. circuit cannot be added arithmetically but must be combined by means of formulas such as those shown in the sketches on this sheet.

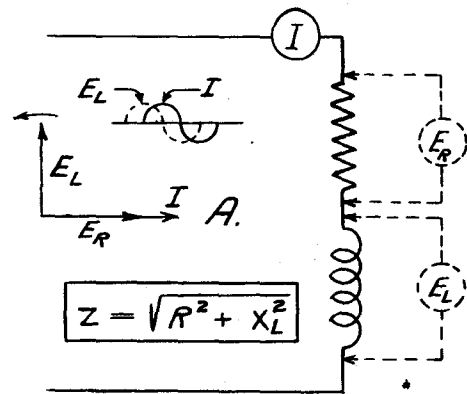

R AND C IN SERIES

The conditions shown in B are similar to those shown in A except that voltage E_C lags E_R by the same amount that E_L leads E_R in A. As the voltage across a pure resistance is always "in phase" with the current flowing through it. E_L leads the current by 90 degrees and E_C lags the current by 90 degrees. The term "out of phase" is used to indicate that two periodically varying quantities do not pass through corresponding values at the same instant. The formula shows how the sum of the effects of resistance and capacity reactance must be obtained. Note that these quantities have direction as well as value. This explains why they cannot be added arithmetically.

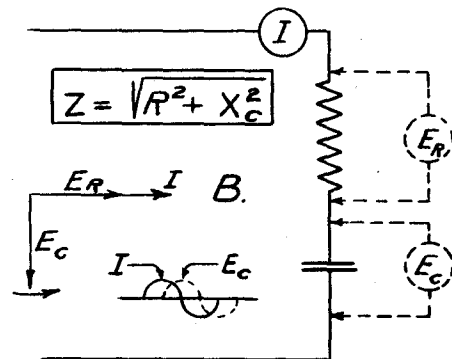

R, L AND C IN SERIES

In C the phase relations are shown for R, L and C in series. E_L leads E_R (or I, for E_R and I are always in phase with each other) by 90 degrees, while E_C lags behind by 90°; consequently voltages E_L and E_C are 180 degrees out of phase with each other and, if they are equal in value, will cancel. Under such conditions, the only opposition remaining in the circuit is due to R; this is the circuit condition required for series resonance. Note carefully the phase relations shown by the vector diagram and sine curves in C. Diagram D shows how it is possible, even in a D.C. circuit, to have voltages in the circuit that are greater than the applied voltage. Note that E_1 and E_2 are in direct opposition to each other; that is, they are 180 degrees out of phase.

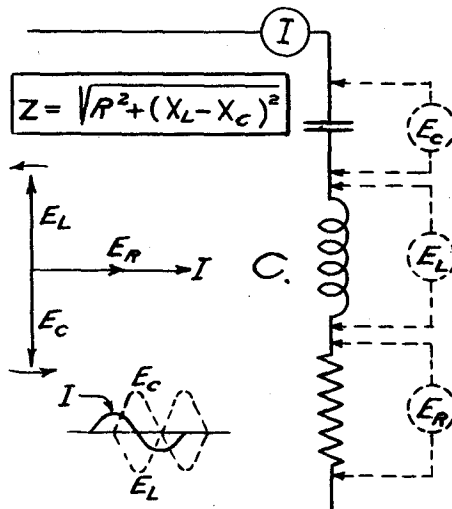

IMPEDANCE

Impedance is the total opposition to current flow encountered by an A.C. current of the A.C. component of a continually varying D.C. current; its symbol is Z and its value is measured in ohms. Impedance may consist of R only, X_L only, X_C only, or any combination of these opposition effects. The formulas for determining Z in terms of R, X_L and X_C are shown in the diagrams.

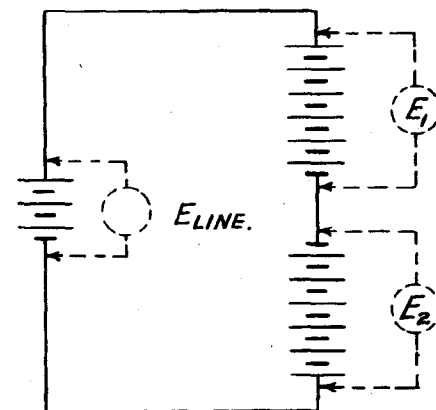

OHM'S LAW FOR A.C. $I = \frac{E}{Z}$ $Z = \frac{E}{I}$ $E = IZ$

RESONANT CIRCUITS.

SERIES RESONANCE

Whether a resonant circuit is the series or the parallel type depends upon the way in which the applied voltage is introduced with respect to L and C. In Fig. A the voltage applied to the circuit is obviously in series with L and C; therefore this circuit is the series type. If the voltage were introduced electromagnetically, as shown by the dotted section, the introduced voltage would still be in series with L and C. The characteristics of the series circuit at resonance are:

1. Current reaches a maximum value.
2. Opposition to current flow becomes minimum.

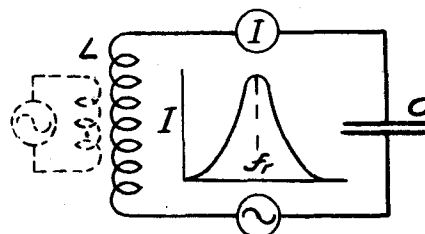

PARALLEL RESONANCE

The circuit shown in B is exactly the same as that shown in A except that L and C are now in parallel with respect to the applied voltage. This arrangement is therefore termed a parallel resonant circuit. Assuming the same values of L and C as used in Fig A, this circuit will become resonant at the same frequency as A. Although both types of circuit may resonate at the same frequency, the effects produced in circuit are very different, for the characteristics of the parallel resonant circuit are:

1. Line current falls to a minimum.
2. Opposition to Line I flow becomes maximum.

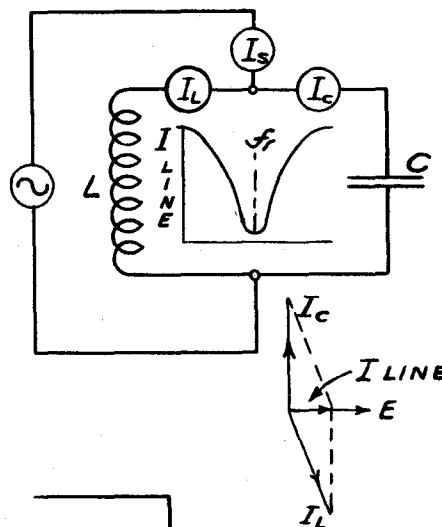

PARALLEL AND SERIES RESONANCE

Fig. C shows two electromagnetically coupled resonant circuits. Frequently used in radio work, this arrangement is employed to introduce a very high impedance into the plate circuit of one tube, the series circuit being employed to provide selection and amplification in the grid circuit of the following tube.

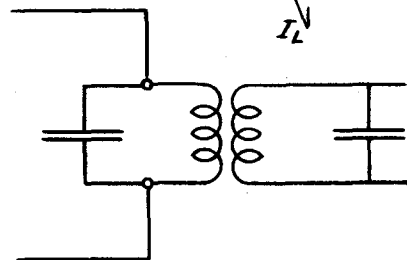

APPLICATION IN THE ANTENNA

Figures 1 and 2 show an application of both types of resonance in the antenna. In 1 a series circuit is used to tune the antenna to the desired frequency; for a given strength of signal this will increase the voltage applied across coil A. In Fig. 2 a parallel resonant circuit is employed to provide a very high impedance to unwanted frequencies. As the series circuit accepts frequencies to which it is tuned, and the parallel circuit rejects them, the former is called an acceptor and the latter a rejector circuit.

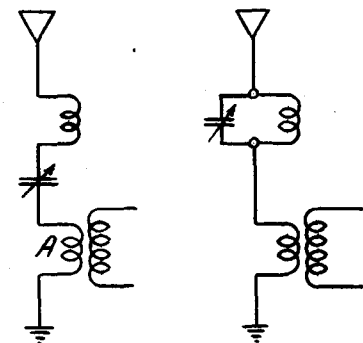

FREQUENCY AND RESONANCE

As the frequency is changed in a circuit containing L and C, the opposition offered varies as shown in Fig. E. As the frequency increases, the inductive reactance increases and the capacitive reactance decreases. At some particular frequency (depending upon the values of L and C) these two effects become equal and neutralize each other. When this happens the only opposition to current flow in the series circuit is the ohmic resistance of the conductors; the resonant point has been reached.

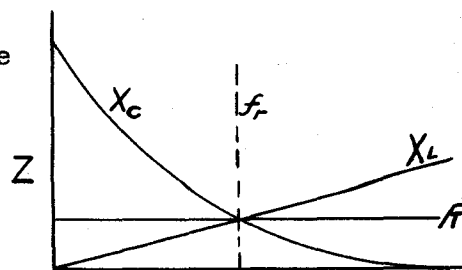

MECHANICAL AND ELECTRICAL RESONANCE.

Resonance in any system, mechanical or electrical, is always accompanied by a change in energy from one form to another. The swinging pendulum, the balanced wheel and spring, and the electrical combination of a coil and a condenser are common examples. If energy is introduced to such systems, it will change from one form to another at a definite frequency.

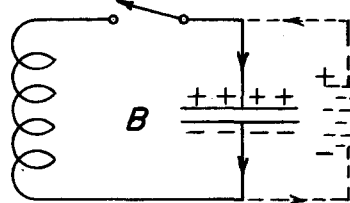
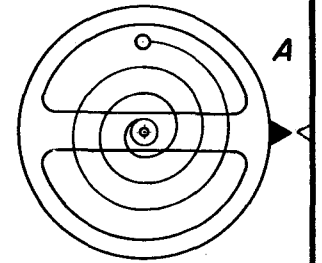
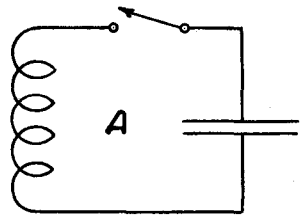

In Fig. A both systems are shown in the normal state, for no energy is stored in either. In Fig. B the wheel has been turned clockwise, thereby storing energy in the coiled spring. Applying a voltage to the condenser has a similar effect, causing the condenser to store electrical energy in the electrostatic form.

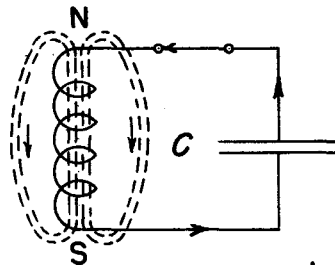
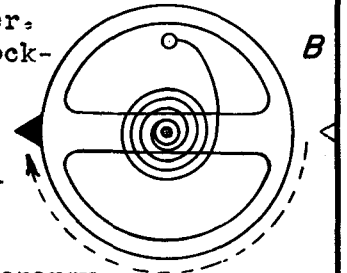

When the wheel is released (Fig. C) the energy stored in the spring is converted to momentum in the wheel. Similarly, when the switch is closed, the electrostatic energy in the condenser is converted into electromagnetic energy in the field built up around the coil as the condenser discharge flows through it.

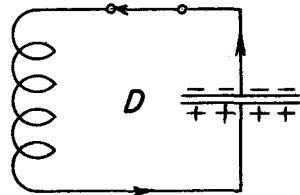
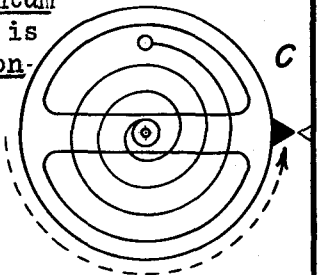

As the coiled spring unwinds and its energy is converted to momentum in the wheel, the latter moves past the normal position and tensions the spring in the opposite sense. Similarly, as the magnetic field collapses, its energy is converted into electrostatic energy in the condenser. Note that the spring is tensioned in the reverse direction, and that the condenser is charged with the opposite polarity. (Fig. D)

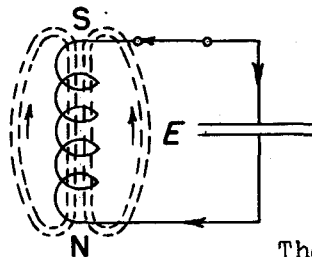
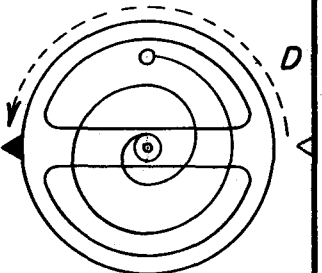

In Fig. E the wheel is a-gain moving past the normal position due to its momentum, and the magnetic field is about to collapse. Fig. F completes the cycle that started with Fig. B. Were it not for friction in the mechanical system, and resistance in the electrical system these oscillations, once started, would continue indefinitely.

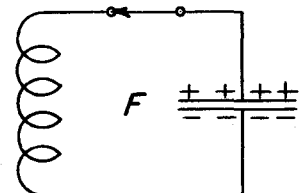
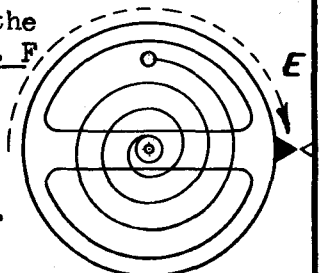

The frequency of the oscillation will, in the mechanical system, depend upon the weight and diameter of the wheel and the stiffness of the spring. In the electrical system the frequency of oscillation is determined by the inductance of the coil and the capacity of the condenser. If the externally introduced energy is of the same frequency as that of the system, small input impulses will create and sustain violent oscillation.

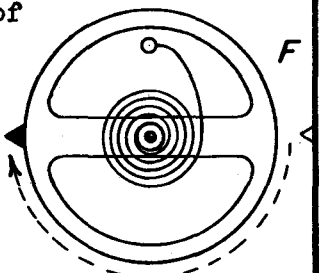

MECHANICAL AND ELECTRICAL RESONANCE.

Another example of an oscillating mechanical system is the pendulum. Moving the pendulum sidewise raises the weight W and stores energy in it by virtue of its position. Note that the pendulum is actually lifted thru distance D . In the electrical resonant system, this would be equivalent to charging the condenser.

When the pendulum is released it moves toward the original position. During this time, the energy of position is converted to energy of motion. By the time the position shown in B has been reached, the pendulum is moving at its most rapid rate, and all of its stored energy has been converted to energy of motion. The electrical equivalent of this would occur as the condenser discharged and built up the magnetic field around the coil.

Due to its momentum, the pendulum continues its motion, the energy of motion being gradually converted to stored energy due to its position. The electrical equivalent of this would occur as the magnetic field of the coil collapsed and charged the condenser.

If there were no windage or frictional effects, the swings on either side of the vertical position would be equal and, once set into motion, the system would oscillate for ever. In the electrical system, it is the resistance of the coil and the losses in the condenser that causes oscillation to cease.

If this mechanical system is disturbed in any way, it will immediately go into oscillation at a definite frequency, this frequency being determined by the length of the supporting string R . As shown in D, quartering the length of R will double the frequency. If the electrical system shown in E is subjected to an electrical impulse, it also will oscillate, the frequency of oscillation being determined by the setting of the variable condenser.

If the pendulum were subjected to several equal sets of externally applied impulses, each set having a different frequency, it will be found that only the set whose frequency closely approximates that of the system will be effective in producing oscillation. If the length of the string be varied, the system may be "tuned" to accept one set of frequencies and reject the others. In this way, the system may be made resonant to any frequency within its range.

By varying the capacity of the variable condenser, the electrical system shown in E may be tuned to respond to electrical impulses of a pre-selected frequency. If several sets of electrical impulses be applied to such a circuit, it will respond only to those that closely approximate the frequency for

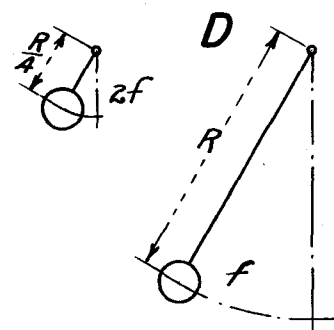
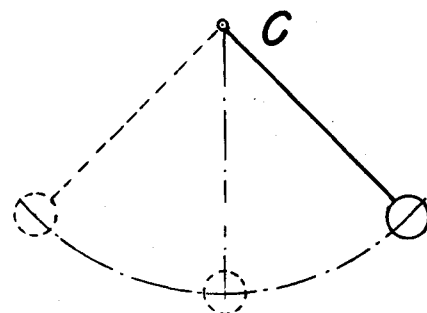
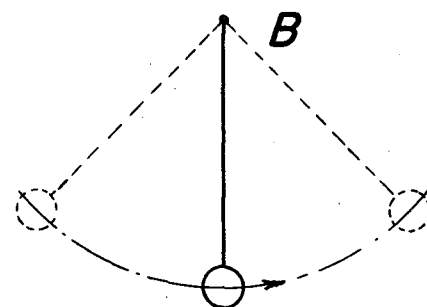
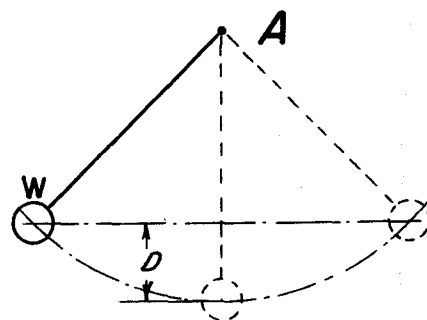

E

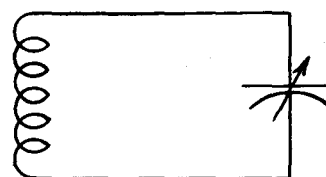

RESONANT CIRCUITS.

Series Resonant Circuit.

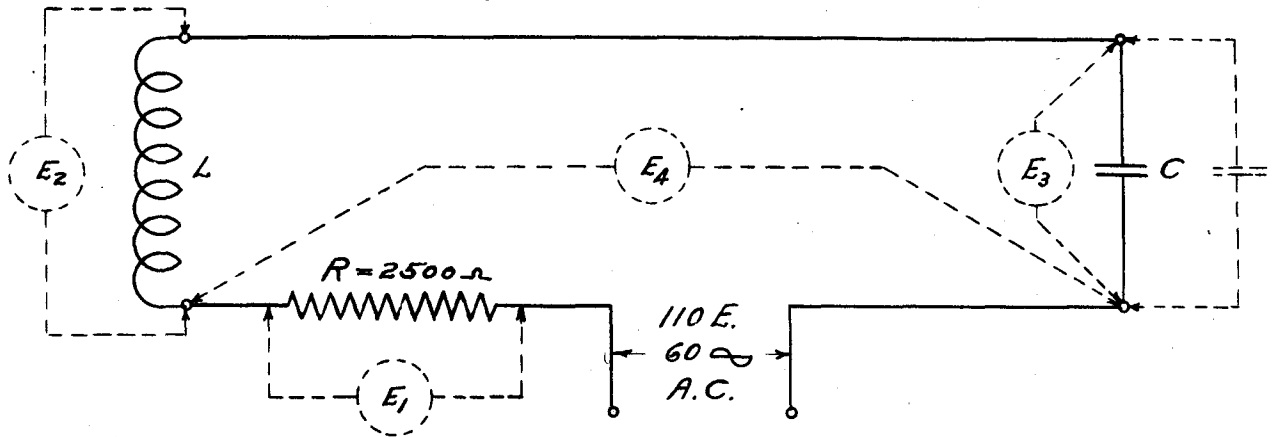

Cond. Capacity in Mfds.	$I = \frac{E_1}{R}$	E_2	E_3	E_4	$X_C = \frac{E_3}{I}$	$X_L = \frac{E_2}{I}$	$Z = \frac{E_4}{I}$

Parallel Resonant Circuit.

Cond. Capacity in Mfds.	$I = \frac{E_1}{R}$	E_2	Z

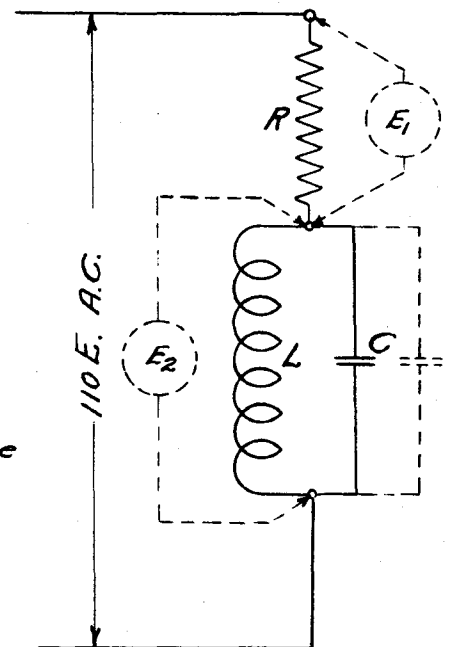

Ⓢ Equation $X_L = \frac{E_2}{I}$ is true only if ohmic resistance of coil is negligible; otherwise $\frac{E_2}{I} = Z_L$. When the ohmic resistance is measurable X_L may be found by first obtaining Z_L and then using formula $X_L = \sqrt{Z_L^2 - R_L^2}$ where R_L equals the ohmic resistance of the coil.

HANDY RADIO FORMULAE

Direct Current Relations

VOLTS =	$I R$	$\frac{W}{I}$	$\frac{\sqrt{R W}}{I}$
AMPERES =	$\frac{E}{R}$	$\frac{W}{E}$	$\frac{\sqrt{W R}}{E}$
OHMS =	$\frac{E}{I}$	$\frac{W}{I^2}$	$\frac{E^2}{W}$
WATTS =	$E I$	$I^2 R$	$\frac{E^2}{R}$

Resistance Relations

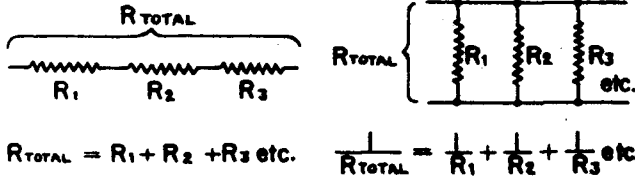

Two Resistances Only

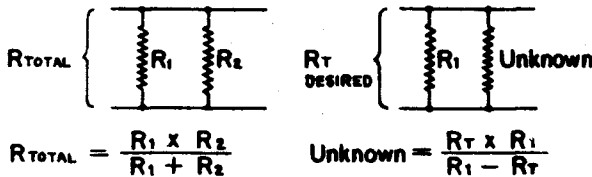

Capacity Relations

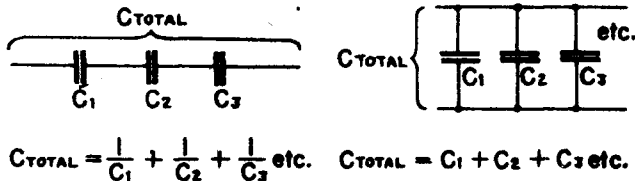

Two Capacities Only

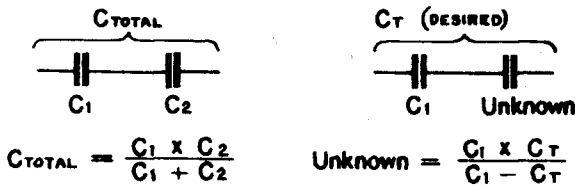

Simple Reactance

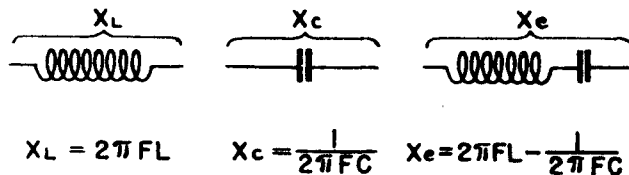

Complex Impedance

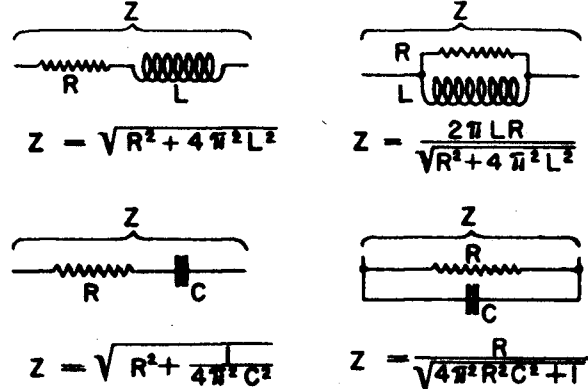

Resonance Formulae

$F = \frac{1}{2\pi\sqrt{LC}}$ $L = \frac{1}{4\pi^2 F^2 C}$ $C = \frac{1}{4\pi^2 F^2 L}$
 Where F is in cycles, L is in henries, and C in Farads

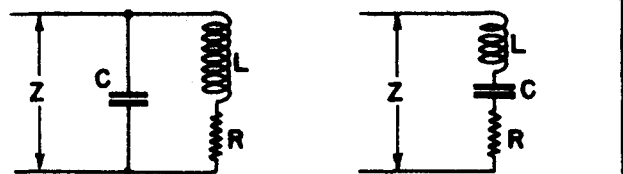

At Resonance:
 $Z = Q 2\pi FL$
 Where $Q = \frac{2\pi FL}{R}$
 At Resonance:
 $Z = R$

Coupling Coefficient

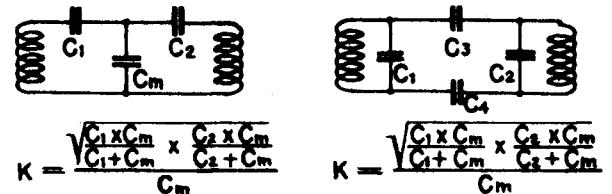
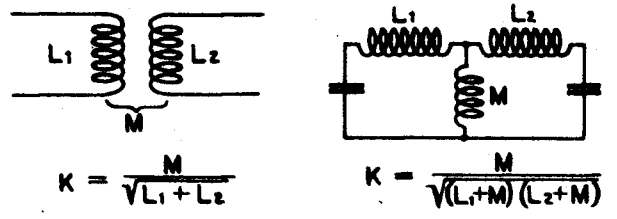

Where $C_m = \frac{C_1 \times C_2}{C_3 + C_4}$

Over-Coupled Circuit Frequencies

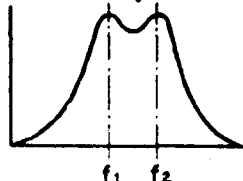
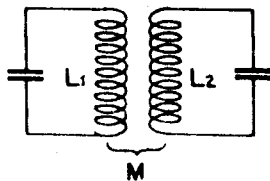

$f_1 = \frac{F}{\sqrt{1+K}}$
 $f_2 = \frac{F}{\sqrt{1-K}}$

Where F is the resonant frequency of each circuit independent of the other and K is the coupling-coefficient

AUTOMOBILE BATTERY GROUND CHART

YEAR	1934	1935	1936	1937	1938	1939	1940	1941	1942
Auburn	Pos.	Pos.	Pos.	Pos.	Neg.	Neg.	Neg.	Neg.	Neg.
Buick	Neg.	Neg.	Neg.	Neg.	Neg.	Neg.	Neg.	Neg.	Neg.
Cadillac	Pos.	Pos.	Pos.	Neg.	Pos.	Pos.	Pos.	Pos.	Pos.
Chevrolet	Neg.	Neg.	Neg.	Neg.	Neg.	Neg.	Neg.	Neg.	Neg.
Chrysler		Pos.	Pos.	Pos.	Pos.	Pos.	Pos.	Pos.	Pos.
Cord		Pos.	Pos.	Pos.	Pos.	Pos.	Pos.	Pos.	Pos.
DeSoto	Pos.	Pos.	Pos.	Pos.	Pos.	Pos.	Pos.	Pos.	Pos.
Dodge	Pos.	Pos.	Pos.	Pos.	Pos.	Pos.	Pos.	Pos.	Pos.
Duesenberg	Neg.	Neg.	Neg.	Pos.	Pos.	Pos.	Pos.	Pos.	Pos.
Ford	Pos.	Pos.	Pos.	Pos.	Pos.	Pos.	Pos.	Pos.	Pos.
Franklin	Pos.								
Graham	Pos.	Pos.	Pos.	Pos.	Pos.	Pos.	Pos.	Pos.	Pos.
Hudson	Pos.	Pos.	Pos.	Pos.	Pos.	Pos.	Pos.	Pos.	Pos.
Hupmobile	Pos.	Pos.	Pos.	Pos.	Pos.	Pos.	Pos.	Pos.	Pos.
Lafayette	Pos.	Pos.	Pos.	Pos.	Pos.	Pos.	Pos.	Pos.	Pos.
LaSalle	Pos.	Pos.	Pos.	Neg.	Pos.	Pos.	Pos.	Pos.	Pos.
Lincoln	Neg.	Neg.	Neg.	Neg.	Neg.	Neg.	Neg.	Neg.	Neg.
Lincoln Zeph.				Pos.	Pos.	Pos.	Pos.	Pos.	Pos.
Mercury									
Nash*	Pos.	Pos.	Pos.	Pos.	Pos.	Pos.	Pos.	Pos.	Pos.
Oldsmobile	Neg.	Neg.	Neg.	Neg.	Neg.	Neg.	Neg.	Neg.	Neg.
Packard	Pos.	Pos.	Pos.	Pos.	Pos.	Pos.	Pos.	Pos.	Pos.
Pierce-Arrow	Pos.	Pos.	Pos.	Pos.	Pos.	Pos.	Pos.	Pos.	Pos.
Plymouth	Pos.	Pos.	Pos.	Pos.	Pos.	Pos.	Pos.	Pos.	Pos.
Pontiac	Neg.	Neg.	Neg.	Neg.	Neg.	Neg.	Neg.	Neg.	Neg.
Studebaker	Pos.	Pos.	Pos.	Pos.	Pos.	Pos.	Pos.	Pos.	Pos.
Terraplane	Pos.	Pos.	Pos.	Pos.	Pos.	Pos.	Pos.	Pos.	Pos.
Willys		Neg.	Neg.	Neg.	Neg.	Neg.	Neg.	Neg.	Neg.

*Some special custom-built models have negative grounded.

Ohms Law for Direct Current

$E = I \times R$ Where:
 $I = \frac{E}{R}$ E = Voltage
 I = Current in Amperes
 $R = \frac{E}{I}$ R = Resistance in Ohms

Resistances in Series

$R_t = R_1 + R_2 + R_3 \dots R_n$
 Where: R_t is the total value of all resistors connected in series.
 $R_1, R_2, etc.,$ are the individual resistors.

Resistance in Parallel

The formula for resistances in parallel is:
 $R_t = \frac{1}{\frac{1}{R_1} + \frac{1}{R_2} + \frac{1}{R_3}} etc.$
 Where: R_t is the effective value of all the resistors connected in parallel.
 R_1, R_2, R_3 are the individual resistors.

This formula may be extended as far as one has resistances in parallel. For an example let us say we have four resistances of 5 ohms, 10 ohms, 20 ohms, and 30 ohms. Substituting in our formula we obtain:

$$R_t = \frac{1}{\frac{1}{5} + \frac{1}{10} + \frac{1}{20} + \frac{1}{30}}$$

$$= \frac{60}{12 + 6 + 3 + 2}$$

$$= \frac{60}{23} = 2.60 \text{ ohms total resistances.}$$

A convenient formula for only two resistances in a parallel circuit is:

$$R_t = \frac{R_1 \times R_2}{R_1 + R_2}$$

By referring back to the formula for resistances in parallel one may readily see how this equation is derived. As an example for

this formula let us use values of 10 ohms and 35 ohms. Substituting in our formula:

$$R_t = \frac{10 \times 35}{10 + 35} = \frac{350}{45} = 7.7 + \text{ ohms}$$

Capacity of Parallel Plates

When two conducting plates are parallel, close together, and of large area, the capacity is given by

$$C = 0.0885 \text{ times } \frac{KS}{t}$$

Where C = capacity in microfarads
 K = dielectric constant
 S = area of one plate in square centimeters
 t = distance between plates in centimeters

Reactance (Capacitive) of a Condenser

$$X_c = \frac{10^6}{2\pi fC}$$

Where: $\pi = 3.14$
 f = frequency
 C = capacity in microfarads

Example: What is the reactance of a 2-mf. condenser at 50 cycles?

$$\frac{10^6}{6.3 \times 50 \times 2} = 1,590 \text{ ohms}$$

Impedance of a Circuit

The impedance of a circuit consisting of a resistor and capacitor in series is:

$$Z = \sqrt{R^2 + X_c^2}$$

The impedance of a circuit consisting of a resistor in parallel with a condenser is:

$$Z = \frac{RX_c}{\sqrt{R^2 + X_c^2}}$$

Reactance (Inductive) of a Coil

$$X_L = 2\pi fL$$

Where $\pi = 3.14$
 f = frequency in cycles per second
 L = inductance in henries

Example: What is the reactance of a 20-henry choke at 50 cycles?

$$6.3 \times 50 \times 20 = 6,300 \text{ ohms}$$

Power Factor of a Condenser

$$Pf = \frac{R}{\sqrt{R^2 + \left(\frac{1}{\omega C}\right)^2}}$$

Where: R = the resistance of the condenser
 $\omega = 6.28$ times the frequency
 C = capacity in farads

On a bridge the resistance (R) is determined by dividing the reading of the series resistance (Rs) by the ratio of A/B (where the resistance of Cs is negligible).

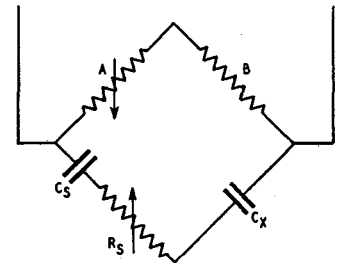

Dissipation Factor Q

The ratio Q of reactance to resistance is generally used as the factor of merit of a coil or condenser and is called the dissipation constant.

For a coil $Q = \frac{\omega L}{R}$

For a condenser $Q = \frac{1}{\omega RC}$

Equivalent Impedance of a Series Circuit

When an inductance, capacity and a resistance are connected in series, the combined effect is called the impedance of the circuit.

$$Z_o = \sqrt{R^2 + (X_L - X_c)^2}$$

Where: Z = impedance in ohms
 R = resistance in ohms
 X_L = reactance of inductance in ohms
 X_c = reactance of capacity in ohms

Equivalent Impedance of a Parallel Circuit

When an inductance, capacity and resistance are connected in parallel the equivalent impedance

$$Z_o = \frac{RX_L X_c}{\sqrt{(RX_L - RX_c)^2 + X_L^2 X_c^2}}$$

Frequency

Where: f = frequency in cycles
 $\pi = 3.14$
 L = inductance in microhenries
 C = capacity in microfarads (mf.)
 $f = \frac{10^6}{2\pi\sqrt{LC}}$

Example: To what frequency will a 0.0005 mf. (500 mmf.) condenser, in parallel with a 180-microhenry coil, tune?

$$\frac{10^6}{6.3\sqrt{180 \times 0.0005}} = 530,000 \text{ cycles} = 530 \text{ kilocycles} = 565 \text{ meters}$$

ANTENNA DIAGRAMS

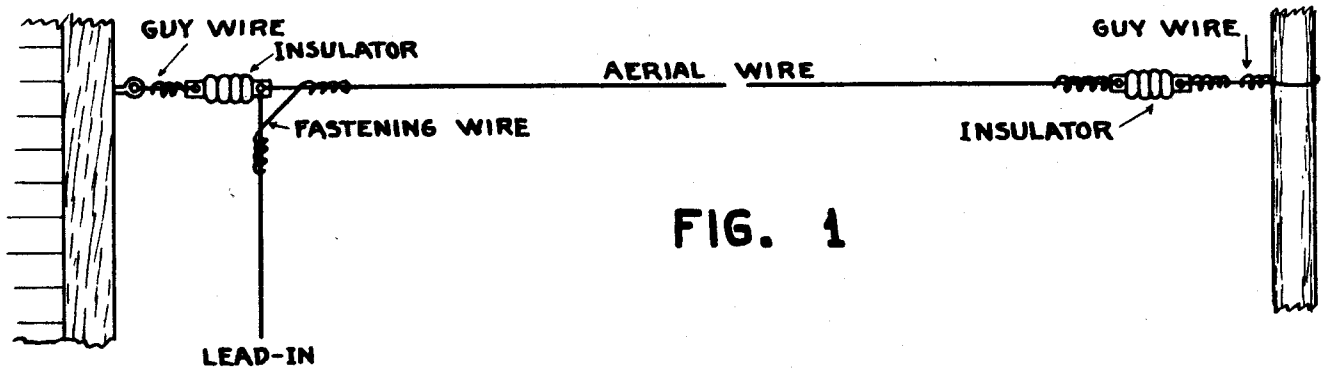

FIG. 1

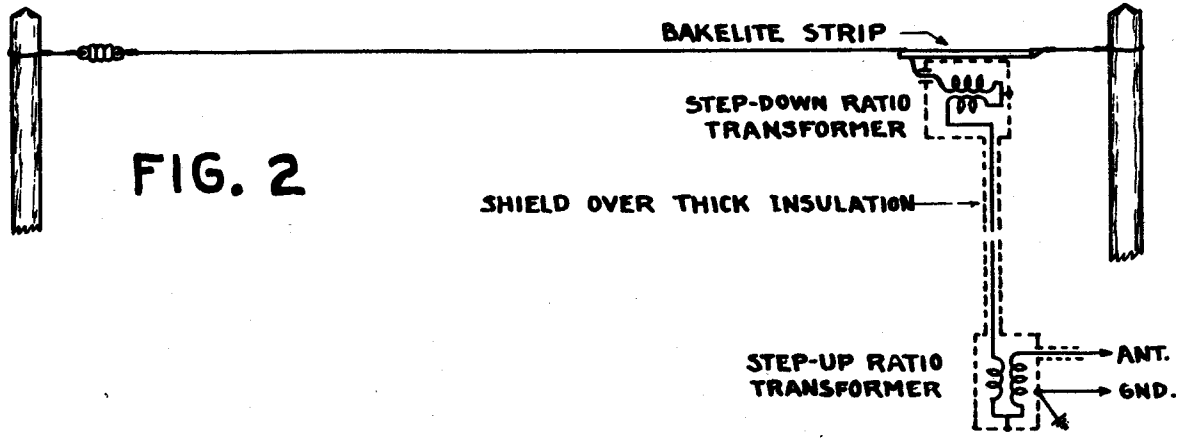

FIG. 2

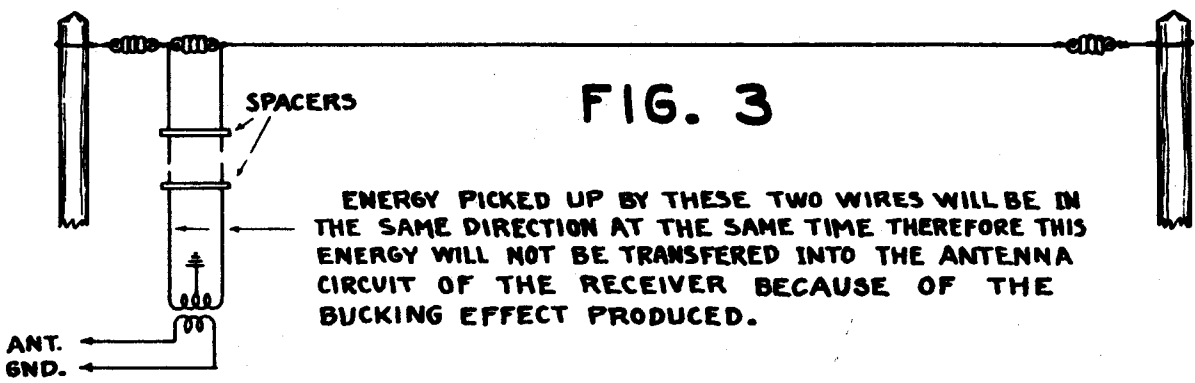

FIG. 3

ENERGY PICKED UP BY THESE TWO WIRES WILL BE IN THE SAME DIRECTION AT THE SAME TIME THEREFORE THIS ENERGY WILL NOT BE TRANSFERRED INTO THE ANTENNA CIRCUIT OF THE RECEIVER BECAUSE OF THE BUCKING EFFECT PRODUCED.

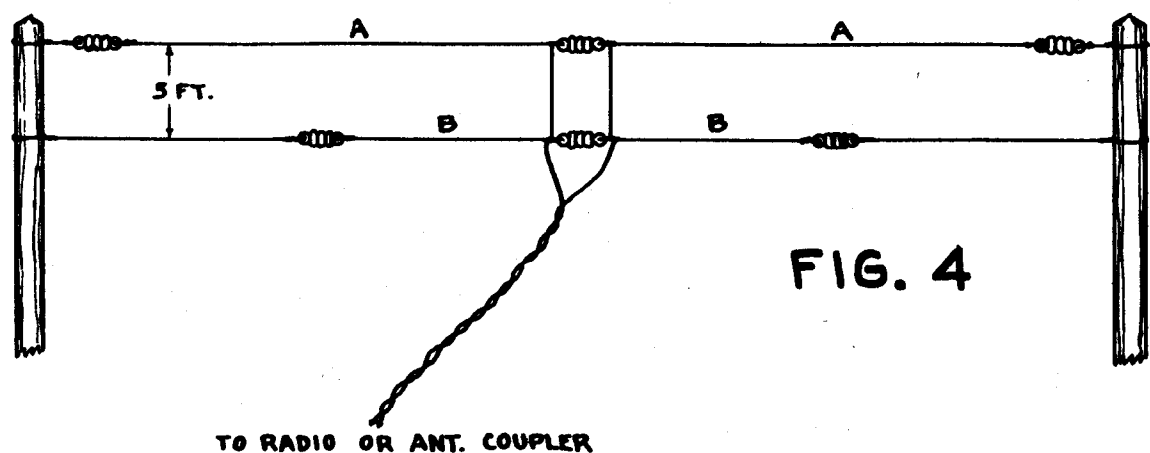

FIG. 4

TO RADIO OR ANT. COUPLER

ANTENNA INFORMATION

An antenna includes the wires or conductors, which extends outside of the receiver and which are effected by the signals coming from a radio transmitter. The common type of antenna consists of one or more wires elevated above the earth.

The antenna system consists of the horizontal wires or antenna proper and the vertical wires or "lead-in". Considering the horizontal portion, the capacity or condenser effect of the antenna increases almost directly with its length up to 100 feet but increases less rapidly for greater lengths. This might be expected since an increase of antenna length increases the area of the condenser which is formed by the antenna and ground. There is only a small change in capacity as the height of the antenna above the ground is increased above 30 feet. From a height of 30 feet up to a height of 120 feet, the decrease in capacity is only about 7%, but as the antenna is lowered under 30 feet, the capacity increases quite rapidly. This effect might also be expected because lowering the antenna brings the parts of this condenser closer together. The capacity of a vertical lead-in wire increases directly with the length of the lead-in. The capacity of the lead-in must be added to that of the antenna to obtain the total capacity of the whole antenna system.

In the following table is given the capacity in mmfds. of the horizontal portion of the antenna and also the capacity of the vertical lead-in. Preceding the hyphen is the capacity in mmfds. of the horizontal portion and following the hyphen is the capacity of the vertical lead-in.

CAPACITY OF HORIZONTAL AND VERTICAL PORTION OF A SINGLE WIRE ANTENNA

Antenna Height in Feet	LENGTH IN FEET OF HORIZONTAL PORTION OF ANTENNA				
	30 Feet Hor-Vert	45 Feet Hor-Vert	60 Feet Hor-Vert	75 Feet Hor-Vert	100 Feet Hor-Vert
20 Feet	59-40 mmfds.	83-40 mmfds.	111-40 mmfds.	139-40 mmfds.	182-40 mmfds.
30 Feet	58-56 "	81-56 "	109-56 "	131-56 "	175-56 "
40 Feet	57-71 "	80-71 "	107-71 "	123-71 "	172-71 "
60 Feet	57-103 "	80-103 "	105-103 "	121-103 "	170-103 "
100 Feet	56-166 "	79-166 "	104-166 "	119-166 "	168-166 "

The effective capacity of the antenna system is somewhat greater at the higher frequencies or lower wave lengths used in broadcasting than at the other end of the scale. Taking the effective capacity of 1000 K.C. or approximately 300 meters as represented by 100%, the following changes are found in practice.

At 1500 K.C. or 200 meters, the capacity is 120% and at 600 K.C. or 500 meters, it is 90% of the value at 1000 K.C.

For an antenna 60 feet long and 40 feet high, the above table shows the capacity of the horizontal section to be 107 mmfds., and that of the vertical portion or lead-in to 71 mmfds. or a total of 178 mmfds. for the entire antenna.

Inductance of the antenna. The horizontal portion of the antenna and vertical lead-in not only have capacity but also have inductance even though they are straight wires. The following table gives the value in microhenries of the horizontal portion of the antenna and the vertical lead-in.

INDUCTANCES OF ANTENNA SYSTEM MICROHENRIES

Antenna Height in Feet	LENGTH IN FEET OF HORIZONTAL PORTION OF ANTENNA				
	30 Feet Hor-Vert	45 Feet Hor-Vert	60 Feet Hor-Vert	75 Feet Hor-Vert	100 Feet Hor-Vert
20 Feet	20-10	30-10	41-10	50-10	68-10
30 Feet	20-15	30-15	41-15	51-15	69-15
40 Feet	20-21	30-21	42-21	52-21	71-21
60 Feet	20-34	30-34	42-34	53-34	72-34
100 Feet	20-61	30-61	42-61	52-61	72-61

The inductance of the antenna and lead-in are not lumped inductance as found in coils, but are distributed over the whole length of these wires. These distributed inductances are due to the changing magnetic field set up around the wires when alternating current flows in them. The total inductance of the antenna and lead-in is not as great as the sum of their separate inductances as would be the case with lumped inductances in series, nor is it as small as the two inductances in parallel.

Practice shows that the approximate effective inductance of antenna and lead-in may be found by adding the two together and dividing the sum by three. Thus, for an antenna system 45 feet long and 40 ft. high, it is seen that the inductance of the horizontal portion is 30 microhenries and of the vertical portion 21 microhenries. Their sum is 51 microhenries and the approximate effective inductance is $1/3$ of 51 or 17 microhenries.

Directional Effect of Antenna. It is often found that signals will be received best from a direction opposite to that in which the antenna runs from the receiver. If the antenna points westward, best reception may be had from points to the east. Unless the antenna is at least 100 ft. long, it will show little directional effect, regardless of the direction it runs and will receive just as well from one point of the compass as any other. Any apparent directional effects are due to local conditions such as interference of trees, buildings, and antenna location in general.

Insulators for Antenna. The end of the antenna farthest from the receiver should be supported with an insulator made especially for this purpose. Good insulators are made of porcelain, glass, Pyrex, or high-grade moulded materials. Glass is excellent but well glazed porcelain is probably as good as glass as long as the glaze is not chipped or cracked.

The far end of the antenna should be fitted with one or two of the insulators as in Figure No. 1, and to the far end of the insulator should be attached 5 or 10 feet of strong galvanized iron wire. This is used to make the mechanical connection to whatever post or other support used.

When running antenna or lead-in wires along walls or around corners, they should be kept well away from the wall by stand-off insulators. A stand-off insulator consists of a piece of glass or porcelain that holds the antenna wire and is itself held by a metal flange or rod that may be fastened to the wall, post or roof edge around which the antenna turns the corner. There should be at least 2 inches of insulation surface between the antenna wire and the nearest part of the metal support. Many stand-off insulators are made with a porcelain bushing, that is a piece of porcelain with a hole through it, which is held in an eye formed on a

metal screw or bolt. These are not as good as the kind which provide a greater length of insulating surface between the antenna and the metal support.

Lead-ins for Antenna. The lead-in includes all antenna circuit connections running from the horizontal portion of the antenna, down the side of the building to the receiving set.

The first rule for a lead-in is to make it short. A lead-in like an antenna has inductance, capacity and resistance, but the inductance and capacity can not be used to such a good advantage as when used in the antenna itself. To make a case, a lead-in 100 feet high used with an antenna only 30 feet long would have three times the inductance and capacity of the antenna itself, but if the lead-in for this 30 foot antenna were reduced to 40 feet, its inductance and capacity would be only about 20% more than that of the antenna.

The lead-in is part of the antenna circuit and within practical limits the lead-in should be kept away from everything, by proper use of stand-off insulators wherever they are required. Because insulated wire is used for the lead-in does not mean it may be dropped over the edge of a roof without any protection. There is no objection to using insulated wire for the lead-in if the wire is properly supported, but neither is there any advantage.

The lead-in wire should be kept away from, or insulated from, walls, ceilings, mouldings, etc., in the room through which it passes on its way to the receiver.

Sometimes, the lead-in is connected nearer the center of the antenna rather than at one end. Then the effective length of the antenna is equal to about 1/2 of its physical length, or half that of an antenna of the same length in feet but having the lead-in at one end. Where the lead-in enters the building, it should be run through a porcelain or glass insulator. Such an insulator may be passed through 9/16 to 3/4 inch hole bored in the window frame. The outer end of the lead-in wire should be scraped perfectly clean and a secure mechanical joint made between it and the antenna wire, which has also been thoroughly cleaned of all insulation or oxide. This joint should then be thoroughly soldered. If it is impossible to solder the joint, wrap it with tin foil, then cover the foil with a layer of rubber tape followed by a layer of friction tape.

If the lead-in wire enters a wall or window through a porcelain insulator, drill the hole for the insulator with a slant so that the outdoor end will tilt downward, thus preventing entrance of rain into the building.

Various kinds of special lead-ins may be purchased. Some of these consist of flat ribbon copper incased in a covering of insulation. Such a device may be laid over the window sill and the window closed tightly over it. The danger in this construction comes from the fact that the insulating covering may be broken through the water from rain or snow will ground the antenna, which means weak signals, or no signals in the receiver.

Never use a lead-in device in the ends of which wires are held by spring clips or similar devices. All such joints corrode with wet weather and after they corrode for a few months, the antenna might just about as well be disconnected. Every joint in the antenna system must either be soldered or else solidly bolted and well-shellacked to keep water from the joint.

After the lead-in has entered the building, it will have to be carried along the walls, base-boards or mouldings until it reaches the receiver. This inside part should be made of well insulated stranded copper wire. From the standpoint of appearance, a silk-covered wire is best, although any other insulated wire will

be as good from the standpoint of radio reception. As a final precaution, bring the lead-in from the building entrance to the receiving set in the straightest line possible, avoiding unnecessary turns.

Kinds of Antenna. Receiving antenna of the outdoor type usually consists of a single straight wire insulated from the support at one end and connected to the receiver at the other end. This is called an inverted L-type antenna. A connection is sometimes made to the center of the elevated wire rather than at one end and the resulting antenna is called a T-type antenna.

Height and Length of Antenna. The effective height of the antenna is considered from an electrical and not physical standpoint. The effective height is usually less than the physical height because of buildings and objects in the antenna field. The higher and longer the antenna the more powerful the signals brought in.

As a rule, it is best to have the horizontal or straight part of the antenna at least 60 to 75 feet long. This does not mean that excellent work cannot be done with 50 feet or less, but that 75 feet may be better. An antenna with the straight horizontal part more than 100 feet long, is not required by modern receivers. With many of the better sets, the result will not be as good with 150 to 200 feet of antenna as with 100 feet or less, considering selectivity, static interference, and everything else that goes to make or mar satisfactory reception.

All of this advice applies to antenna used for broadcast receivers. Reception from long wave commercial stations will require a much longer antenna, and short wave reception will call for much shorter antenna.

The best length of antenna depends on local conditions and on the type of receiver being employed. The following list gives lengths that are satisfactory generally. These lengths are the sum of the horizontal part of the antenna, the lead-in to the receiver, and the ground connection from the receiver.

For receivers having 6 or more tubes	40 to 50 feet
For 5 tube, T.R.F. sets.	60 to 75 feet
For 4 tube sets with one R.F. stage.	80 to 100 feet
For 3 tube regenerating receivers.	100 to 120 feet
For 1 tube sets, crystal sets, etc.	100 to 150 feet

Wire of Antenna. For antenna wire, first choice should be stranded enameled copper or phosphor bronze, the second choice is solid wire enamel covered. Antenna wire should be of No. 14 or No. 12 gauge.

Copper is the best of all conductors for radio impulses, but copper oxide is very poor. Since radio impulses travel near the surface of the wire, if this surface is composed of the high resistance copper oxide, such an antenna has lost much of its effectiveness as a conductor of signals.

Shielded Lead-in. In many installations, as in apartment houses, hotels, etc., it is necessary to install the aerial wire a considerable distance above or away from the receiver.

The long lead-in wire, also serves to pick up some radio signals, but it also has electrical impulses induced in it by any electrical appliances used in the building.

Elevator motors and switching devices, relay contacts on electric refrigerators, etc., may induce considerable disturbing voltages in it, so that reception becomes extremely noisy. In cases of this kind, the lead-in wires should be shielded.

We also have what is known as the impedance matched antenna kits, which are composed of impedance matched transformers, one of which is connected at the antenna end where it connects to the horizontal portion of the antenna, the other connects to the receiver end of the lead-in; the top transformer steps the voltage down which reduces loss of energy due to capacity between lead-in and shield.

The interference commonly called static, which may be picked up by the antenna system, can be divided into two types. First, atmospheric static, produced by sparks discharges between two unlike charged particles in the atmosphere, and also by solar radiation; second, man-made static produced by various types of electrical equipment.

Atmospheric static exists on practically all frequencies although there is a marked decrease in the strength of this type of static on extremely short wave, particularly below 10 meters.

Man-made static is just the reverse, its strength being greater on short waves. The ignition system of an automobile radiates the maximum amount of its energy around 10 meters.

It is not possible to reduce atmospheric static when receiving amplitude modulated carrier without producing a corresponding decrease in the transmitter signal, but it is possible to erect an antenna system that will reduce the pick-up of man-made static without materially reducing the pick-up of the signal from the transmitter. This is done by placing the horizontal portion of the antenna high above the earth so that it will be out of the strong man-made static field and then shield the lead-in, or construct the lead in so that the energy it picks up is balanced out and is, therefore, not transferred into the receiver. There are various ways of doing this as shown in Figure No. 2 and No. 3.

Since the length of the antenna system will greatly determine the particular frequency to which it will best respond, it is apparent that the ordinary antenna will not give the same efficiency on both short and broadcast waves. This makes it desirable to use on all wave receivers a special type of antenna made of several sections, each one different lengths so that the longest section will be effective on broadcast while the shortest section will be effective as the antenna for short waves. Such an antenna is shown in Figure No. 4.

FUNDAMENTAL PRINCIPLES OF VACUUM TUBES

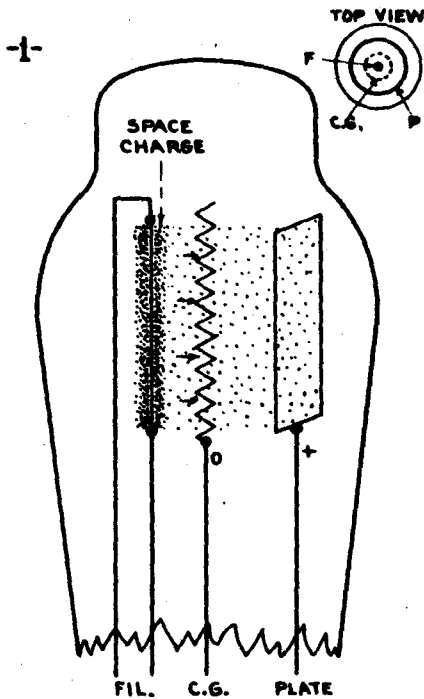

A three element tube with the grid at zero potential. Note that only a few electrons reach the positive plate, and a large number collect around the filament forming a "space charge."

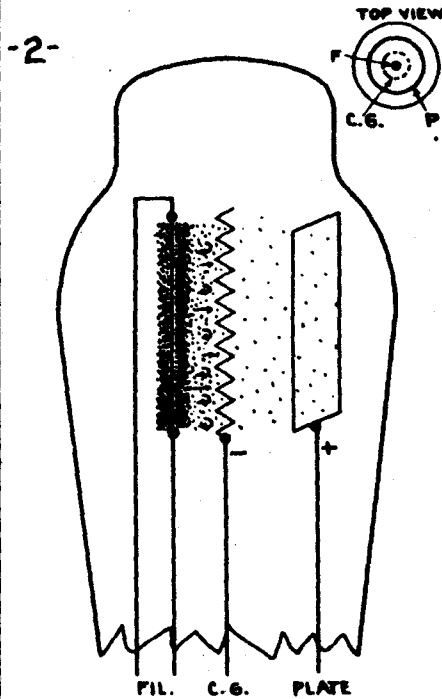

The same tube as #1 with a negative potential on the grid. Less electrons now reach the plate and plate current is lower.

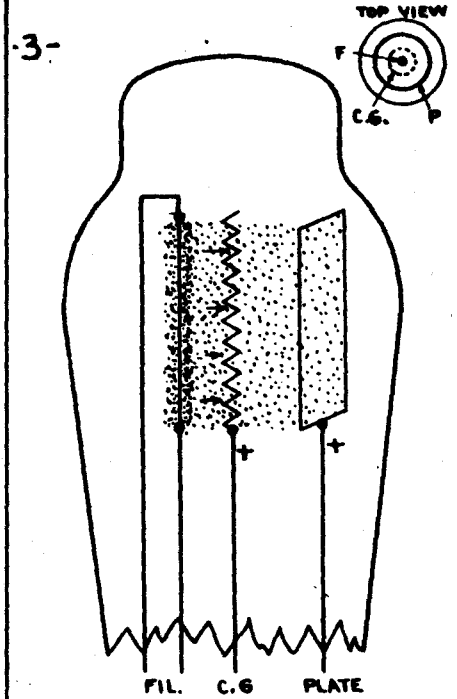

The grid in this diagram has a positive charge which increases the electron flow, and plate current, and also effectively reduces the "space charge."

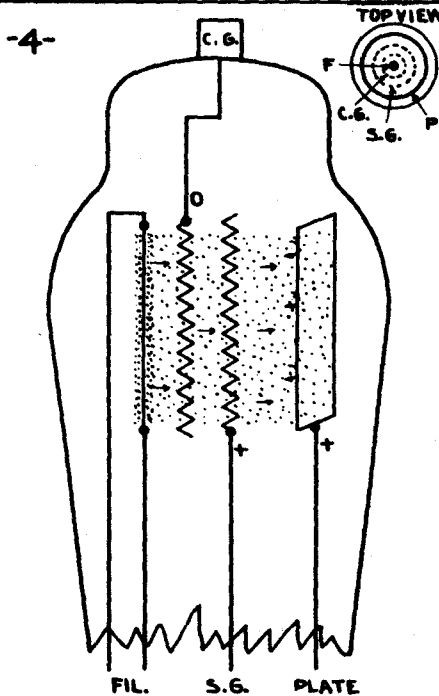

In this tube an extra grid (screen grid) is located between the plate and control grid. This grid has a positive potential applied to it. In this position it reduces the capacity effect between the plate and control grid, increasing the control range of

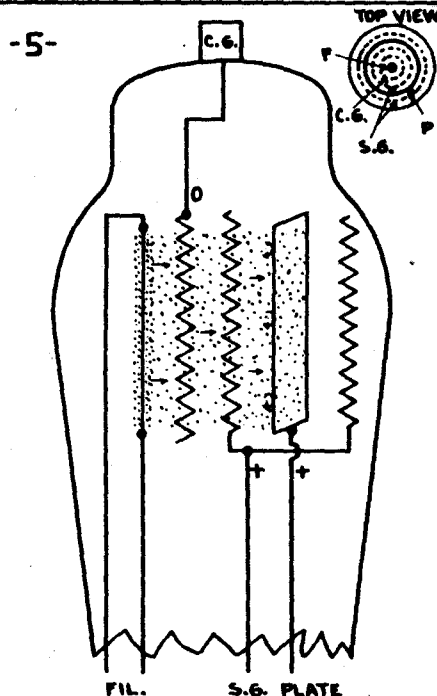

Note in this tube that the extra grid, known as the screen grid, completely encircles the plate. The inner part of the grid both reduces space charge and capacity between plate and control grid. The outer part merely reduces capacity effect between the outside of plate

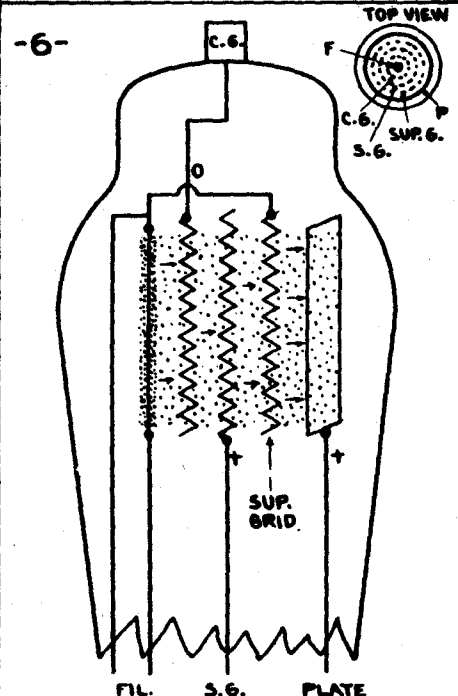

This tube, known as a pentode, has another element (suppressor grid) connected to the cathode or filament, that prevents the undesirable effects of secondary emission, which is due to the electrons from the cathode striking the plate with such force as to set free other electrons. See Fig. 4 and 5.

TRACING "B" CURRENTS IN TUBE CIRCUITS

Three-element, filament-type, battery-operated tube. 30, .01A, 40, 11, 12, 20, 71A.

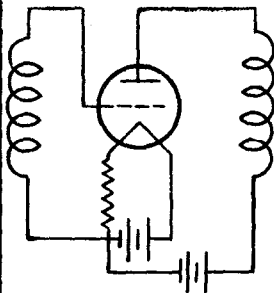

Three-element, filament-type, AC-operated tube. 45, 26, 71A, 10, 50, 2A3.

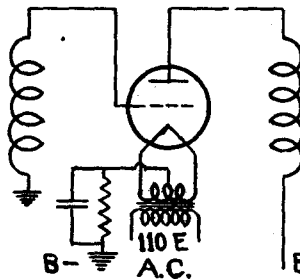

Three-element, filament-type, AC-operated tube employing a hum control. (No specific tube type listed)

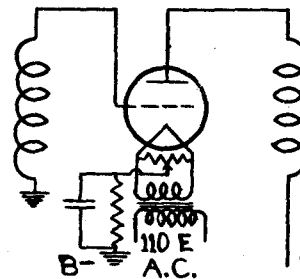

Three-element heater-type tube. 27, 37, 56, 76.

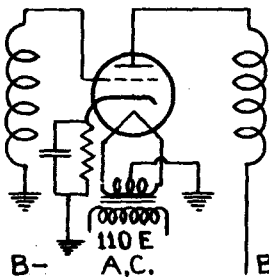

Screen-grid, heater-type tube. 24A, 35, 51, 36.

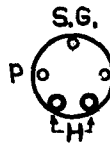
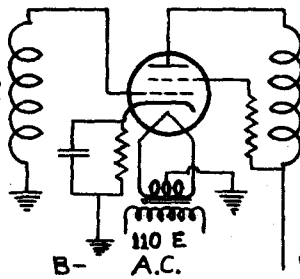

A.F. pentode, heater-type tube. 41, 42, 43

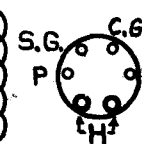
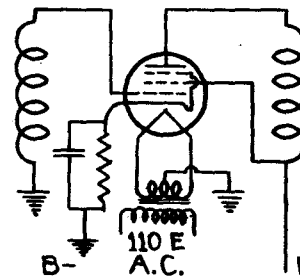

A.F. pentode, heater-type tube. 47, 38, 6A4.

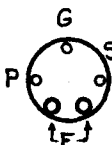
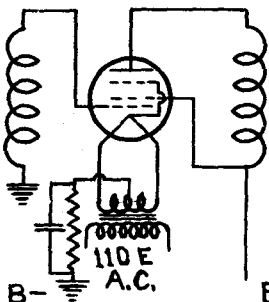

R.F. pentode, heater-type tube. 57, 58, 6C6, 6D6.

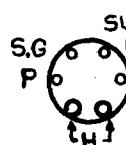
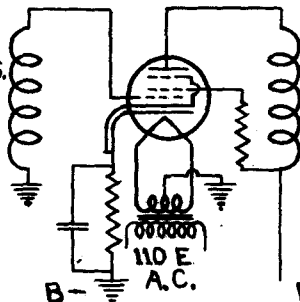

- F - Filament
- H - Heater
- K - Cathode
- P - Plate
- G - Grid
- C.G - Control grid
- S.G - Screen Grid
- SUP.G - Suppressor grid

POWER PACK

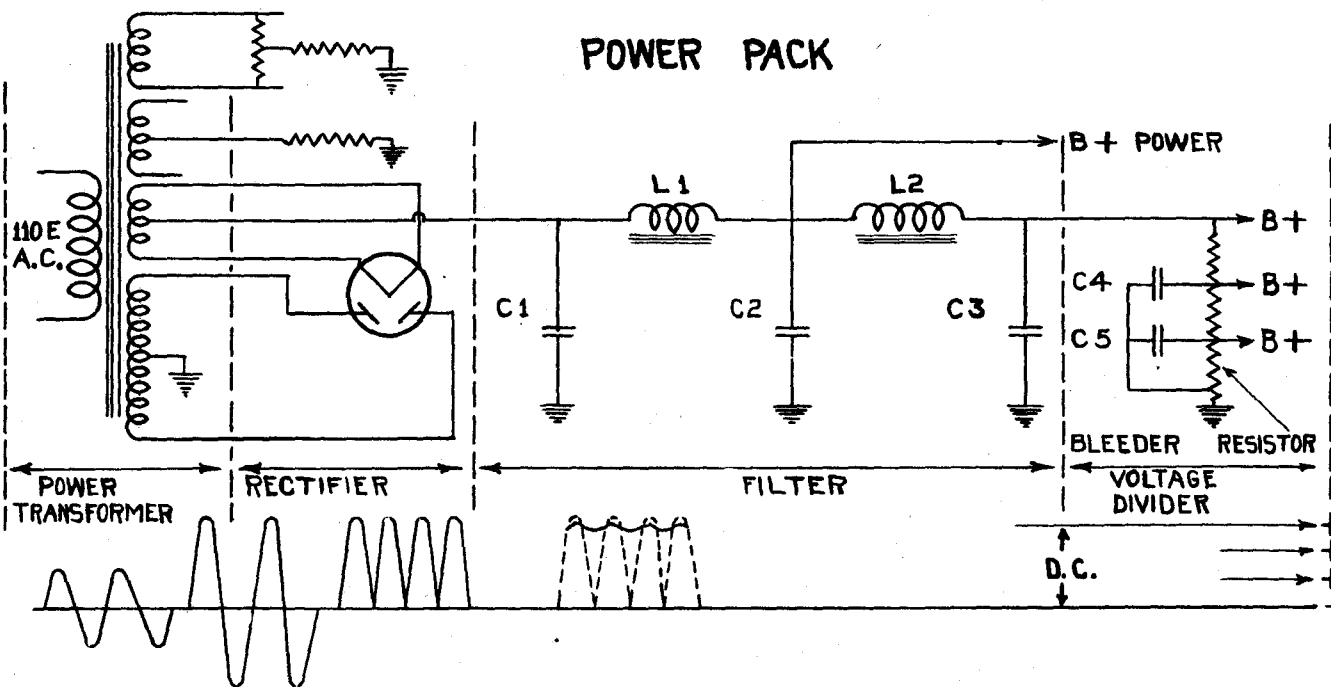

GRID BIAS

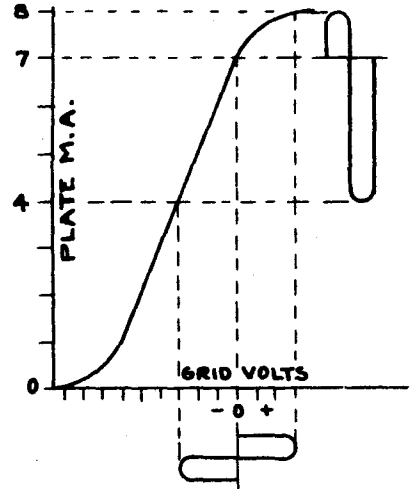
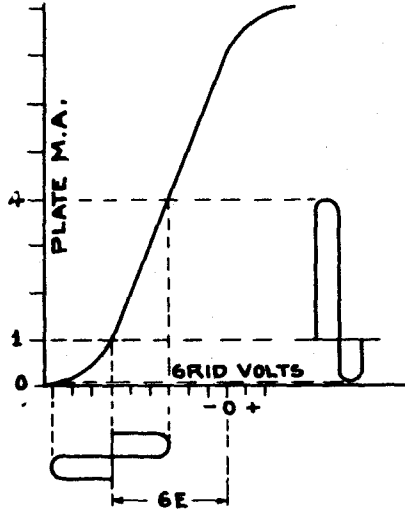
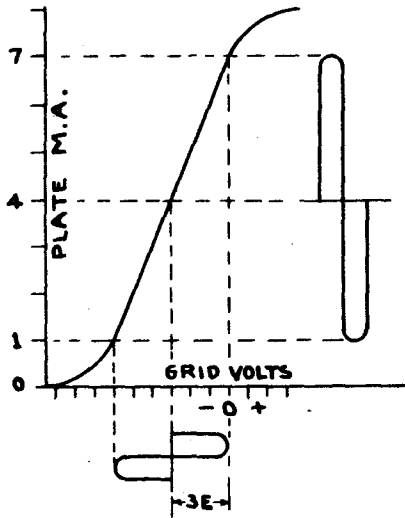

PUSH PULL

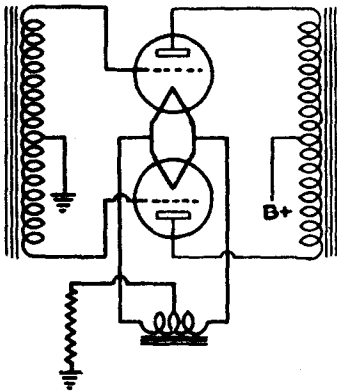

FILAMENT TYPE

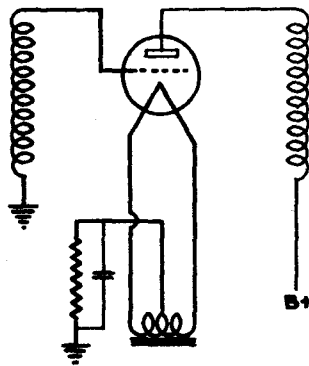

FILAMENT TYPE

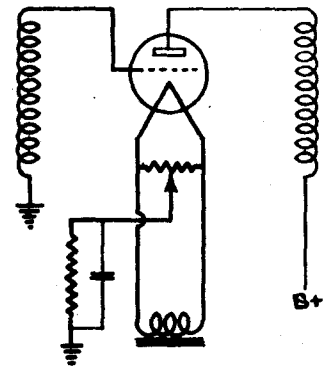

HEATER TYPE

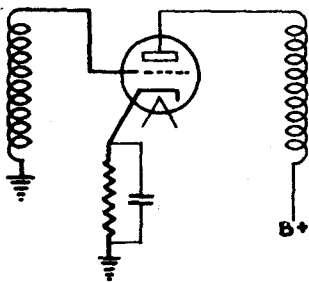

SCREEN GRID TYPE

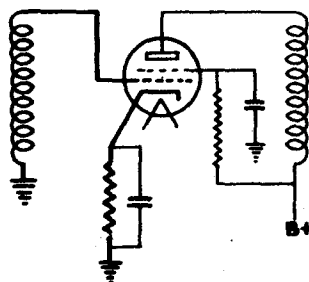

PENTODE TYPE

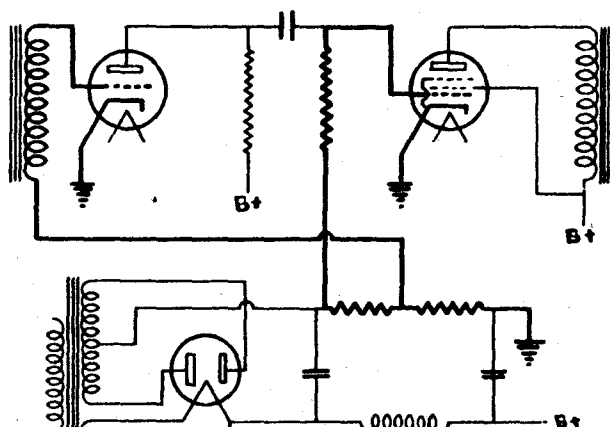
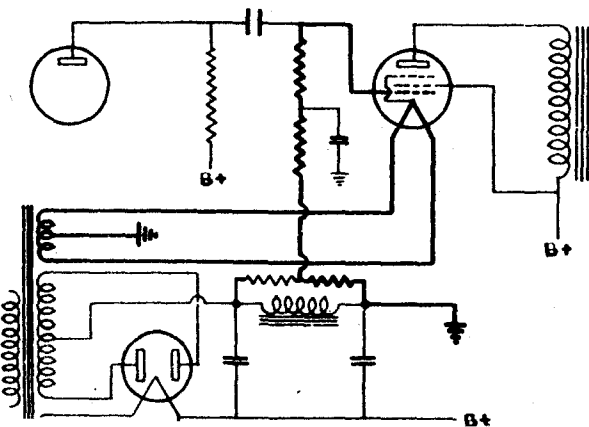
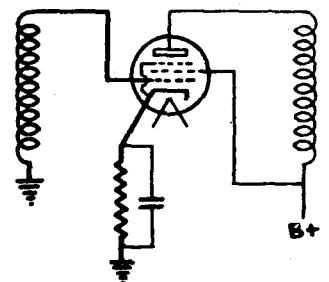

POWER DETECTORS

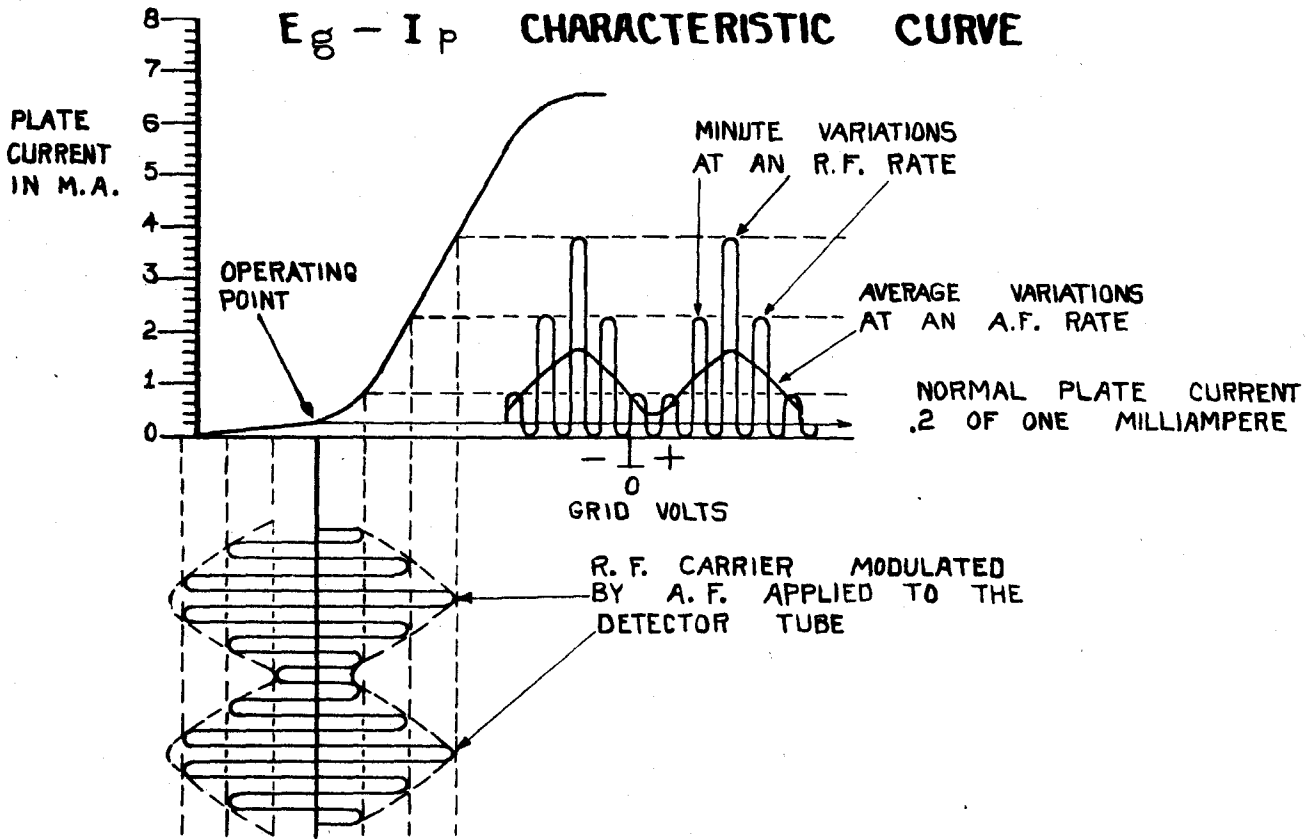

R. F. FILTER CIRCUITS

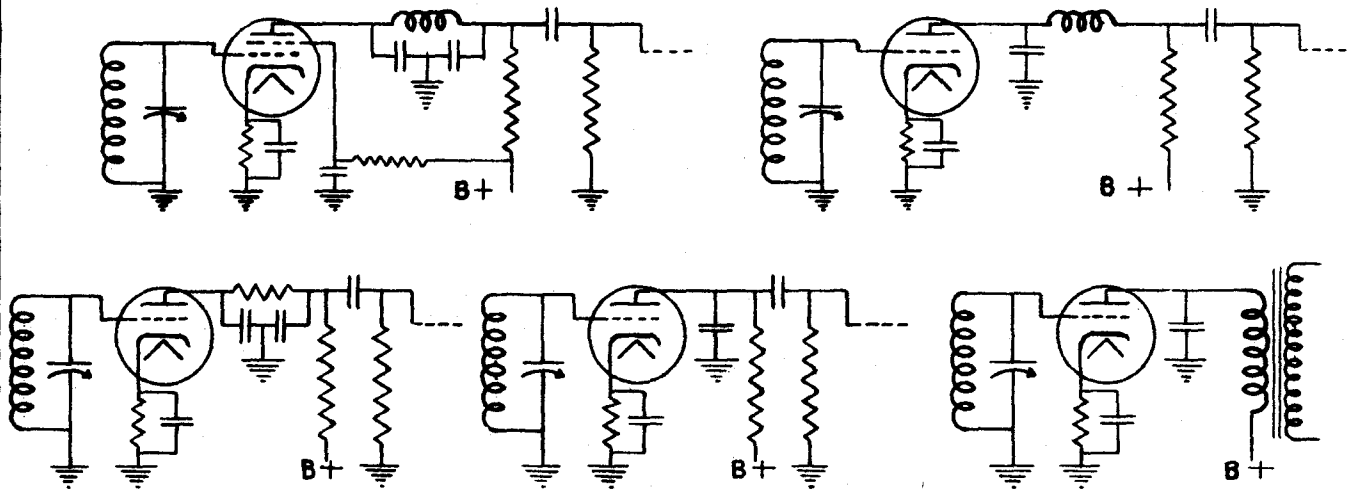

LOFTIN - WHITE

SIMPLIFIED DIAGRAM OF THE LOFTIN - WHITE

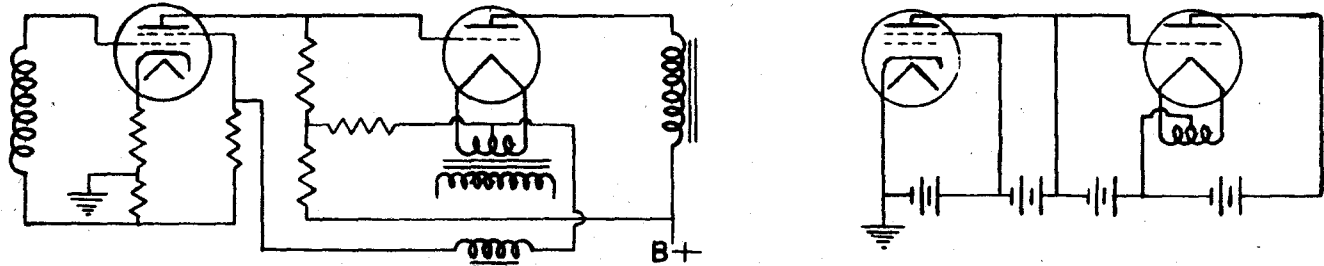

3 STAGE RESISTANCE COUPLED A.F. AMPLIFIER

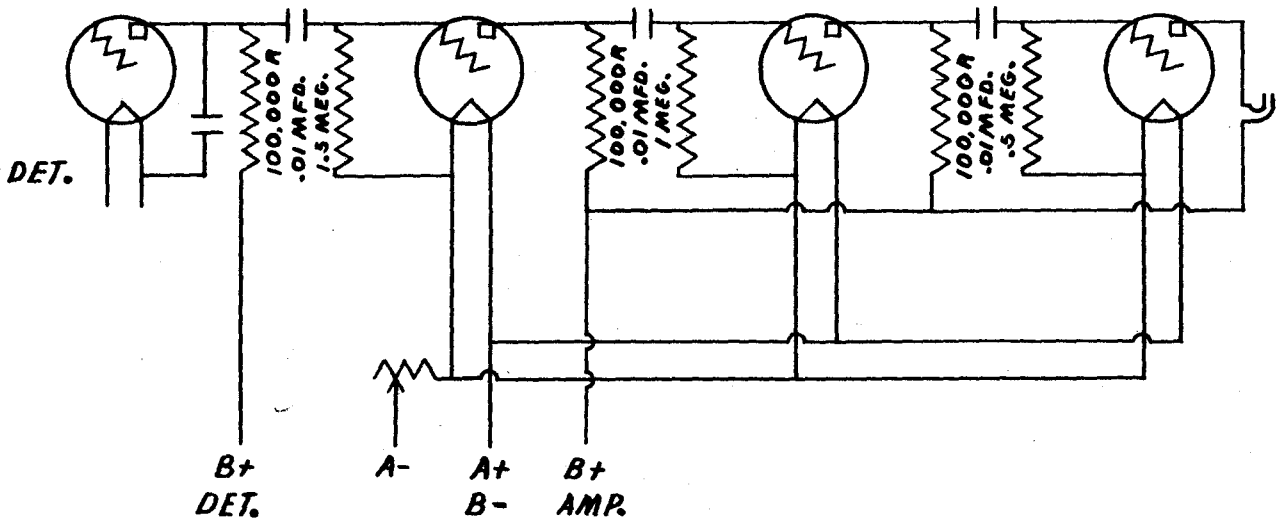

PUSH-PULL AMPLIFIER

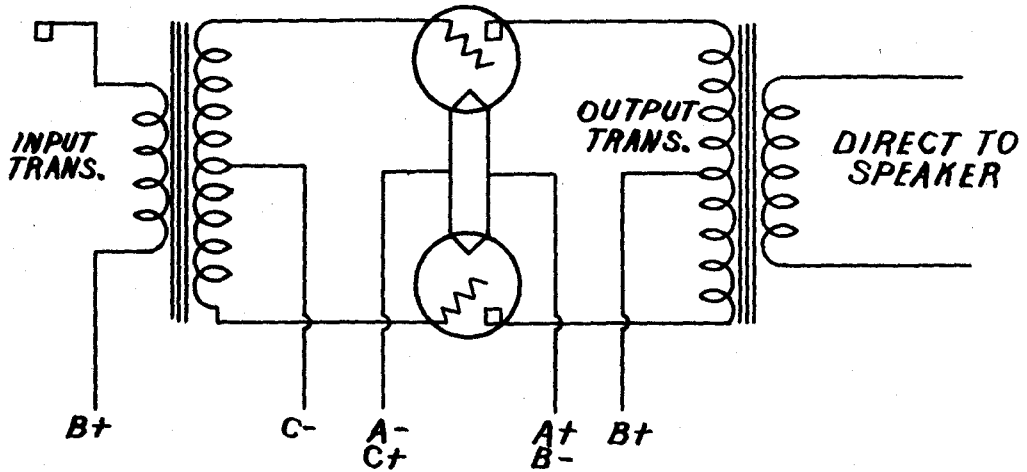

TRANSFORMER COUPLED AMPLIFIER

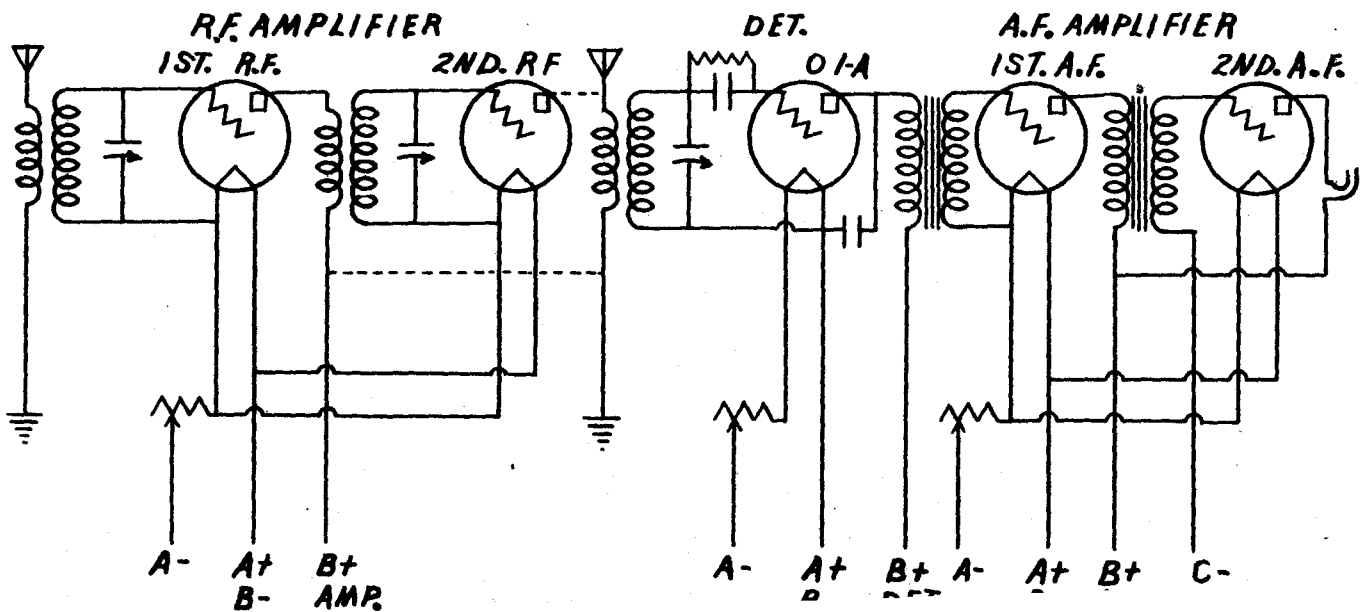

METHODS OF CONNECTING EXTRA SPEAKERS.

EXTRA MAGNETIC SPEAKERS CONNECTED TO A RECEIVER HAVING A DYNAMIC SPEAKER.

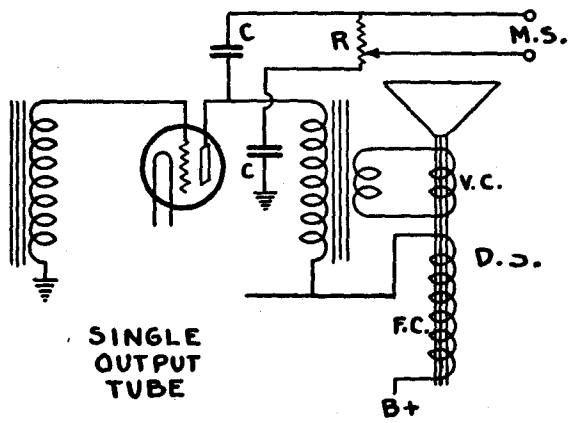

SINGLE
OUTPUT
TUBE

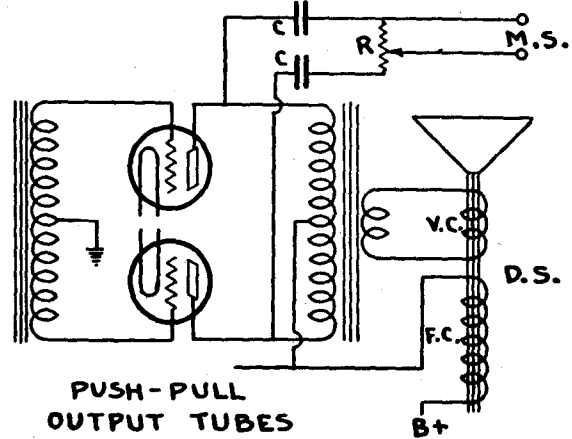

PUSH-PULL
OUTPUT TUBES

EXTRA DYNAMIC SPEAKERS CONNECTED TO A RECEIVER HAVING A DYNAMIC SPEAKER.

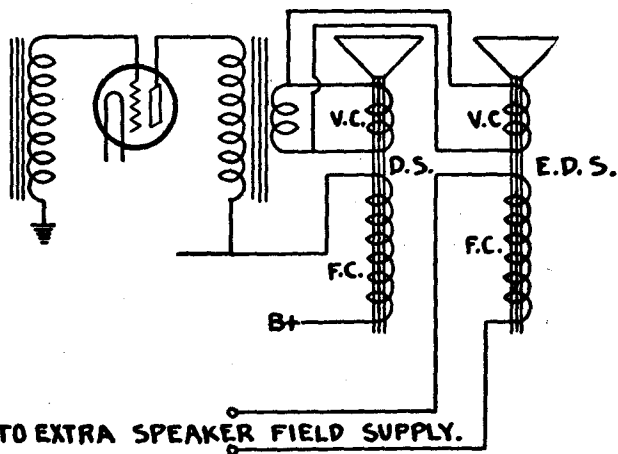

TO EXTRA SPEAKER FIELD SUPPLY.

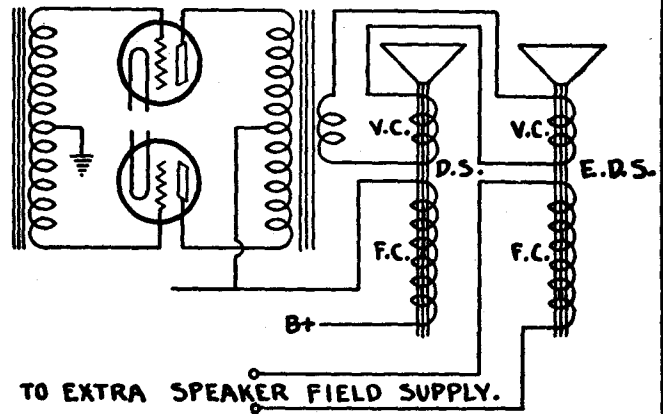

TO EXTRA SPEAKER FIELD SUPPLY.

M.S. = MAGNETIC SPEAKER.
C. = .25 TO 4. MFD.
R. = 20,000 TO 50,000 OHMS.
D.S. = DYNAMIC SPEAKER ON THE SET.
F.C. = FIELD COIL. V.C. = VOICE COIL.
E.D.S. = EXTRA DYNAMIC SPEAKER.

NOTE:- VOICE COILS OF EQUAL
IMPEDANCES MAY BE CONNECTED
IN SERIES OR PARALLEL. VOICE
COILS OF UNEQUAL IMPEDANCES
SHOULD BE CONNECTED IN SERIES.

METHODS OF EXCITING SPEAKER FIELDS.

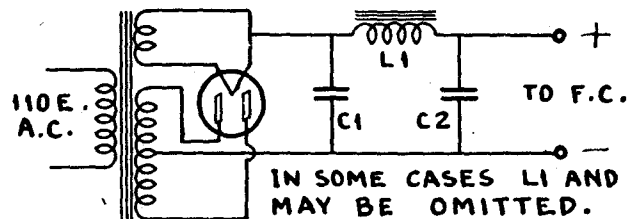
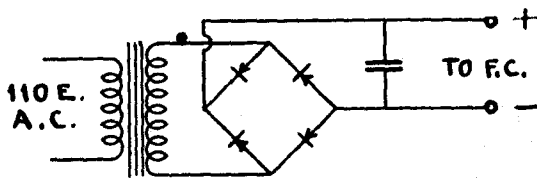

IN SOME CASES L1 AND C2
MAY BE OMITTED.

METHODS OF CONNECTING PHONES TO A.F. STAGES FOR TEST PURPOSES ETC.

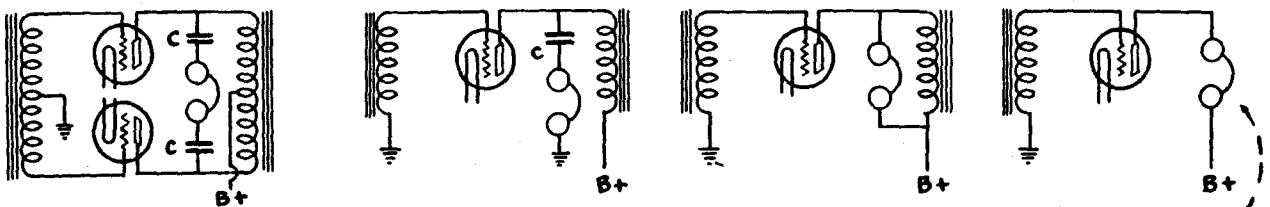

DO NOT CONNECT PHONES IN SERIES WITH THE PLATE CIRCUIT IF I_p IS MORE THAN 25 M.A. COVNE.

METHODS OF DETERMINING SIZE OF BAFFLE BOARDS AND METHODS OF PHASING
TWO OR MORE SPEAKERS.

* * * * *

The purpose of a baffle board is to increase the distance a sound wave must travel in passing from the front to the back of a speaker and vice versa.

Referring to Fig. 1, you will note that the cone passes through four distinct movements as shown by the arrows numbered from 1 to 4 inclusive. This produces a complete sound wave, as indicated by the dotted curved line through the speakers. The time required to produce each distinct movement, is equal to the time required to produce 1/4 wave length of the sound wave being produced. Note also that the pressure changes produced on opposite sides of the cone are at any given instant opposite to each other - that is - a pressure exists on one side and a rarefaction on the other.

These pressure disturbances, which are actually the sound waves, travel away from the cone at a speed of about 1130 Ft. per second, and have a tendency to pass around the edge of the cone. If the sound wave has time to pass from one side of the cone to the other during one distinct movement, a maximum compression will combine with a maximum rarefaction resulting in suppression of that particular sound wave. This explains why a baffle board should be used to increase the effective length of the sound path as shown in Fig. 2.

When the cone is producing a low frequency note, it is moving more slowly than when operating on high frequency notes, therefore, a low frequency note would have a greater length of time to travel to the opposite side of the cone, making necessary the use of a larger baffle board - to prevent suppression of low notes - than is required for high notes. If all edges of the board are free so that the sound can pass around them, the cone should be mounted in the center of the board. In case one side of the baffle board is fitted tightly against a wall or ceiling, the cone may be mounted close to wall or ceiling, since these surfaces will serve as an extension to the baffle board. The effective length of the baffle is always equal to the shortest distance around the edge of the board. Since the time required for sound to travel around the edge of the board to produce maximum suppression is equal to the time required to produce 1/4 wave length of the sound wave being produced, it is evident that we must make the "Effective Length" equal to 1/4 wave length of a given frequency, to prevent suppression of all sound above this frequency. But

$$\text{Wave Length} = \frac{\text{Velocity}}{\text{Frequency}}$$

Therefore,

$$\text{Effective Length} = \frac{1}{4} \times \frac{1130}{\text{Frequency}} = \frac{282}{\text{Frequency}}$$

The following example shows a practical application of this formula. Suppose that we wish to find the distance from edge to edge of a baffle board required to bring out all frequencies, down to 50 cycles per second with a one foot cone speaker. By the formula:

$$\text{Effective length} = \frac{282}{\text{Frequency}}$$

By substitution:

$$\text{Effective length} = \frac{282}{50} = 5.6 \text{ ft.}$$

Assuming the cone to be in the center of the board, then A will equal B. But A plus B = effective length. Therefore, 5.6 plus 1 = 6.6 ft. = distance from edge to edge of board.

The box type baffle of Fig. 2 illustrates how a baffle board, large enough to bring out very low notes, can be confined to a small space.

The infinite baffle is designed to prevent suppression of all frequencies down to the lowest frequency range of the human ear. The felt padded grids will absorb a large amount of the back sound wave and will help a great deal to prevent acoustical feedback when a microphone is located back of the speaker.

The type and shape of the proper baffle to use depends upon the shape of the territory to be served. It is desirable to have as near a uniform volume distribution as possible. If the area served is square, then a flat baffle board would give best distribution of sound. If the room is rectangular, then a directional baffle is best. The trumpet type horn will serve an area of about 30 angular degrees directly in front of the speaker making it the best type of baffle for long distance coverage; hence, very desirable for outdoor installation.

The baffle board must never act as a sounding board. It should be made of some non-resonant material such as 3/4" thick celotex, papier-mache, or soft wood at least 3/4" thick.

SPEAKER PHASING

When two or more speakers are connected to a common amplifier and are serving the same area, it is necessary that they produce the same change in the air pressure at the same time. If this condition exists the speakers are said to be in phase, and they will deliver to the air the greatest amount of acoustical power possible.

If one is close to the speakers when they are thrown alternately in and out of phase, the change in volume is barely perceptible; but if one is some distance from the speakers, the reduction in volume when the speakers are out of phase is very evident.

It is well to keep in mind that sound waves are pressure variations and that the volume of sound depends upon the amplitude of these variations. It is possible to have a large amount of air movement, such as exist with high winds, and still have very little sound produced.

In Fig. 3B, the speakers are facing opposite directions as sometimes desired in outdoor installations. In this case, the speakers are in phase when they are moving in the opposite directions at the same time, as shown in sketch.

A very simple way to check speakers for the purpose of phasing, is to disconnect speakers from amplifiers and connect a battery into the speaker circuit as shown in Fig. 3A. The end of the loose wire serves as a switch. The wire is pressed against the battery terminal and then removed, thus closing and opening the battery circuit. The battery circuit should be normally left open and closed for only a short instant, because the voice coils have such a low resistance that enough current will flow to destroy them. With the field coils excited, place your finger on the center of one cone and then close the battery circuit for an instant. Make a mental note of the direction in which the cone of the speaker moves. Then place the finger on the center of the cone of another speaker and check the direction in which it moves when the battery circuit is closed. The cone of all speakers should move in the same direction. Reverse the voice coil connections on any speaker that moves in a direction opposite to that desired.

If the movement of the cone is not perceptible, when the battery circuit is closed increase the battery voltage to get a noticeable movement. The direction of any cone can be reversed with respect to its former movement by reversing the connections to either the voice coil or the field coil, but not both at the same time.

Fig. 3C, shows another method of checking phasing. The speakers are connected to the amplifier and are placed tightly against each other as shown in sketch. When the speaker cones are caused to move - by touching the grid of the first detector or first audio amplifier tube - they should move toward each other, or away from each other, at the same instant: this action will cause air to rush in and out between the contacting cone surfaces and will vibrate a piece of thin paper held close to the cone edges. This test is not generally as satisfactory as the test previously mentioned, and should not be used in preference to those outlined earlier in this article.

FIG. 1

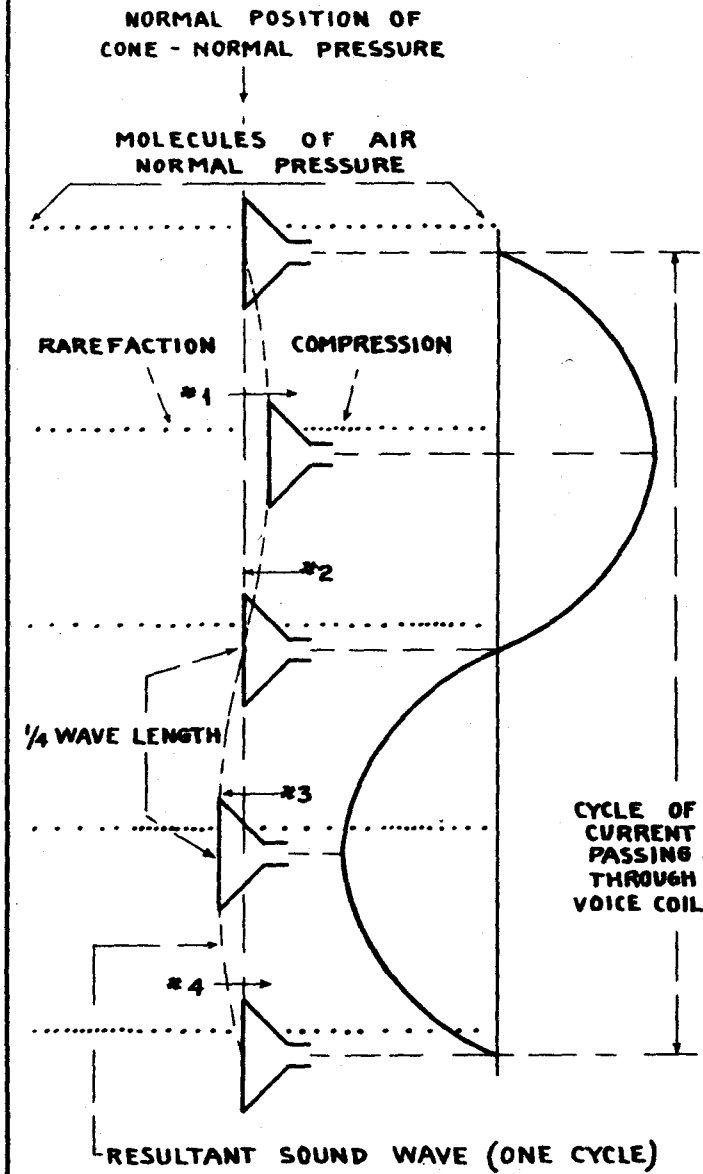

FIG. 2

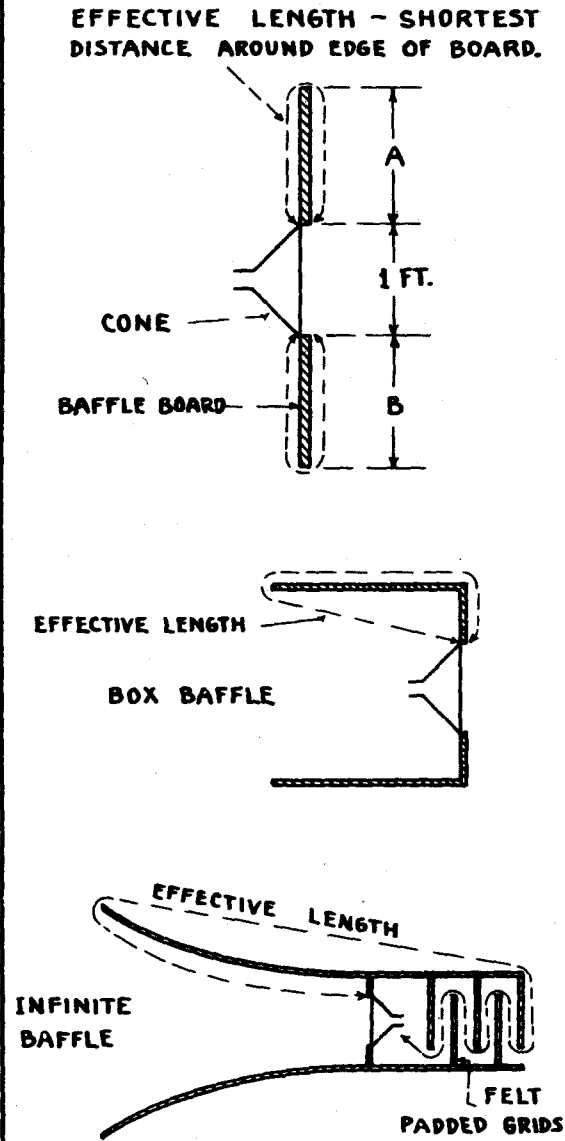
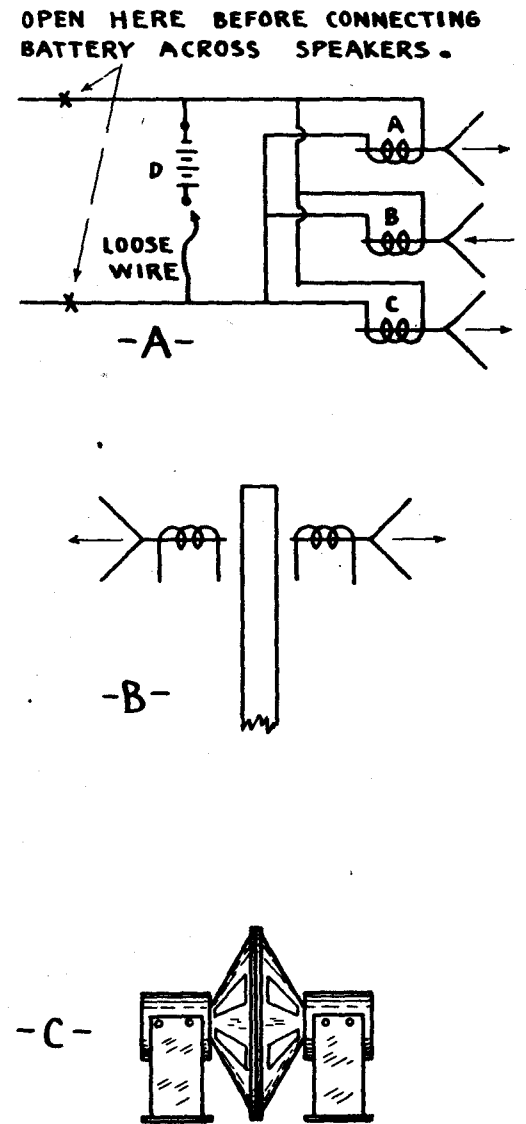
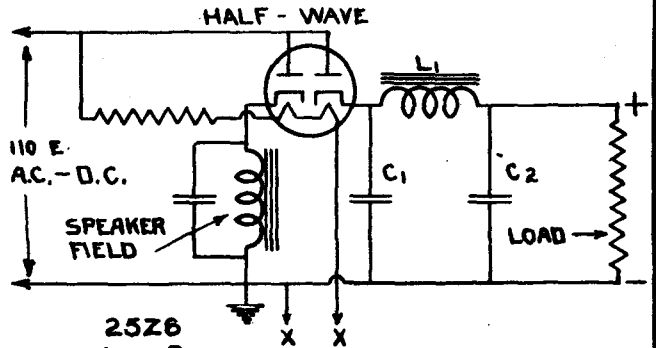
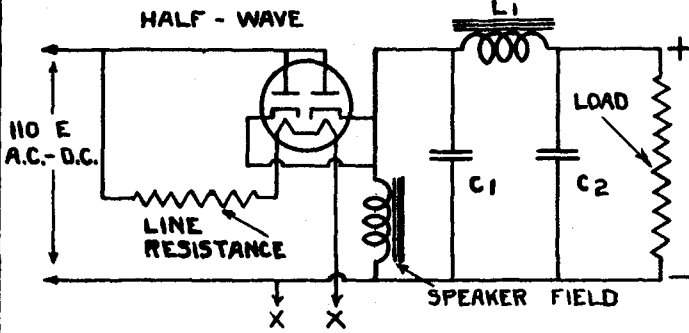
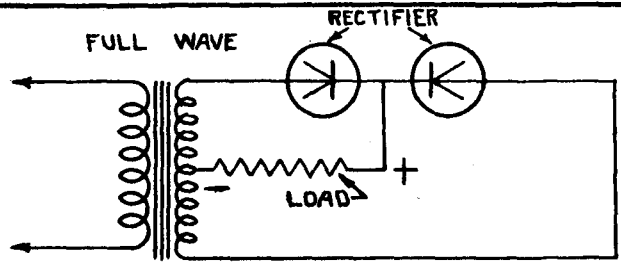
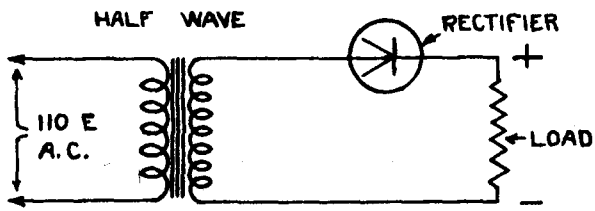

FIG. 3



RECTIFIERS



K...CATHODE
P...PLATE
H...HEATER

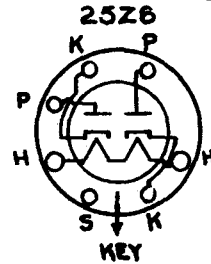
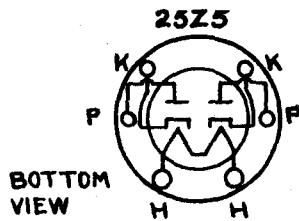

K...CATHODE
P...PLATE
H...HEATER
S...SHELL

VOLTAGE DOUBLER

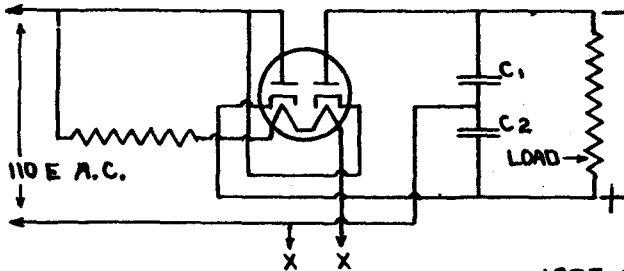

HALF WAVE

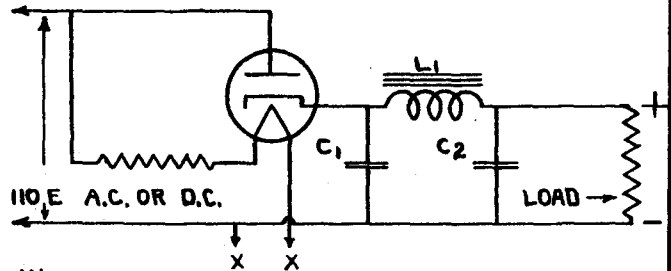

NOTICE

X X --- INDICATES CONNECTIONS TO OTHER HEATERS IN SERIES

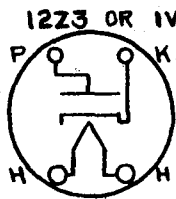

BOTTOM VIEW

K...CATHODE
P...PLATE
H...HEATER

FULL-WAVE

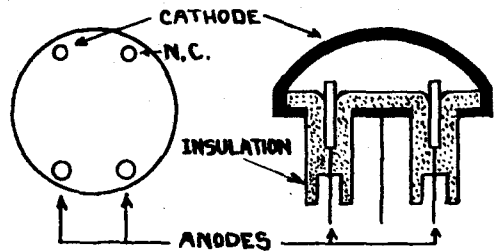
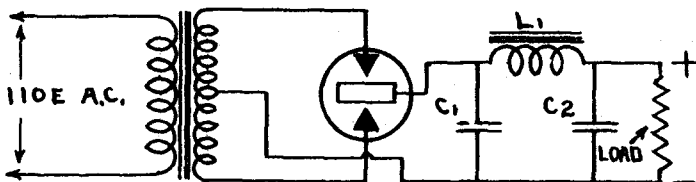

FULL-WAVE

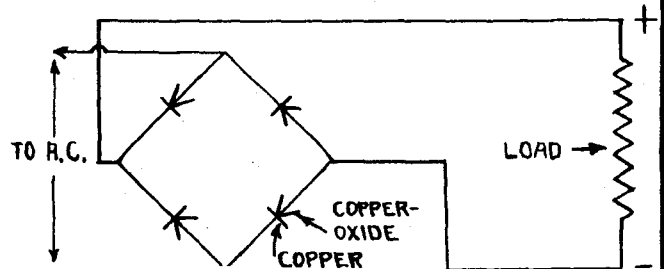
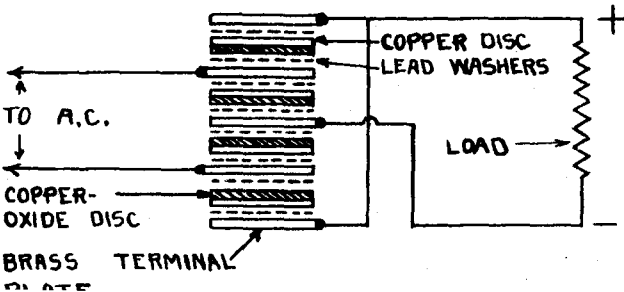

60 CYCLE A.C. TO D.C. POWER SUPPLY.

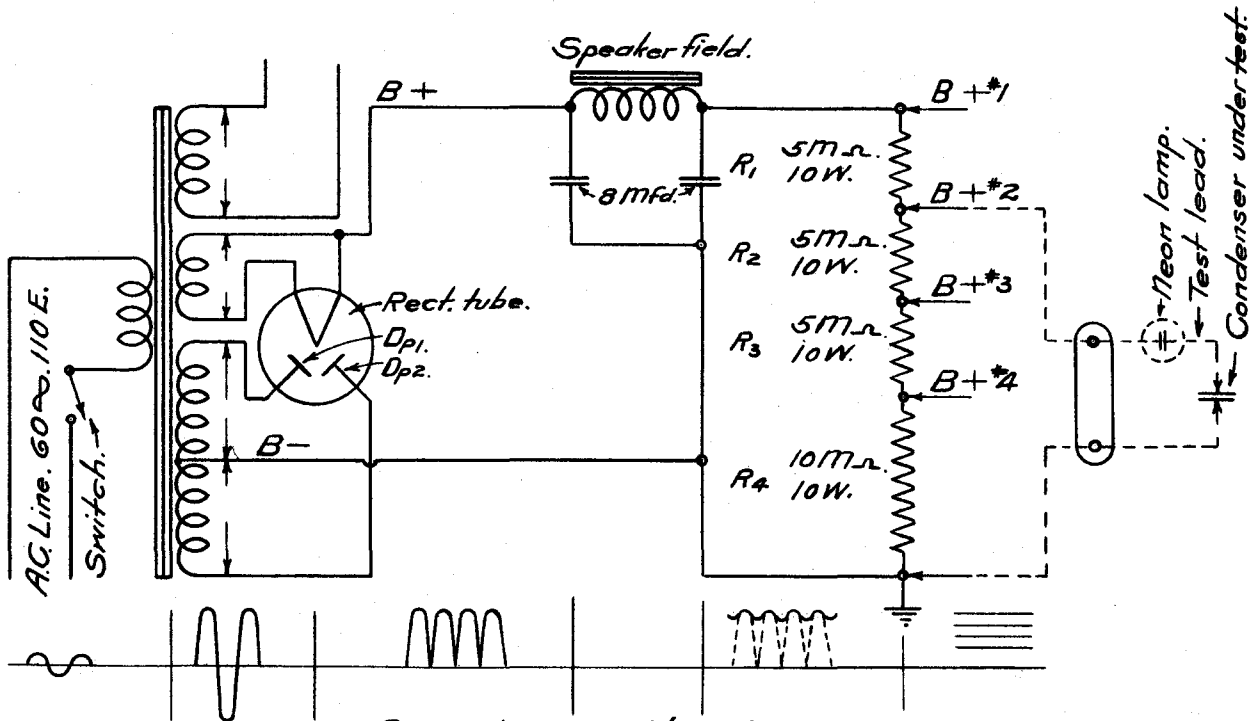

Resistance Chart.

Rectifier tube No. ---	Fil. to Fil.	B+ to B-	Dp ₁ to emitter.	Dp ₁ to ground.	Dp ₁ to Dp ₂
			Dp ₂ to emitter.	Dp ₂ to ground.	

• Voltage Analysis Chart.

	A.C. voltages measured from				D.C. voltages measured from				
	Fil. to Fil.	Dp ₁ to gnd.	Dp ₂ to gnd.	Add Dp ₁ to Dp ₂ Do not measure.	B+ to B-	B+*1 to B-	B+*2 to B-	B+*3 to B-	B+*4 to B-
Before Rect. is inserted.									
After Rect. is inserted.									

• Be sure that voltage to be measured is within the range of the meter otherwise the instrument will be damaged.

	Voltage (E _d) measured across					Rectifier output D.C. current	
	Choke.	R ₁	R ₂	R ₃	R ₄	Calculated.	Measured.
Before Rect. is inserted.							
After Rect. is inserted.							

POWER TRANSFORMER

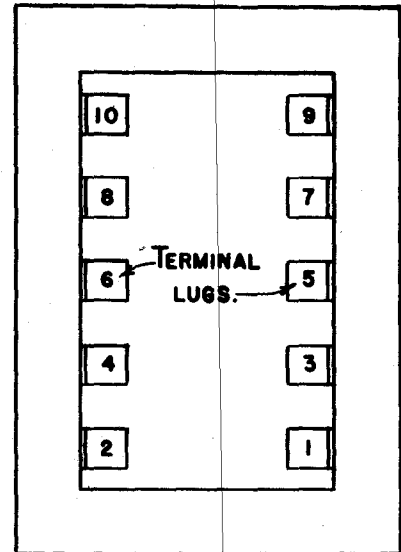
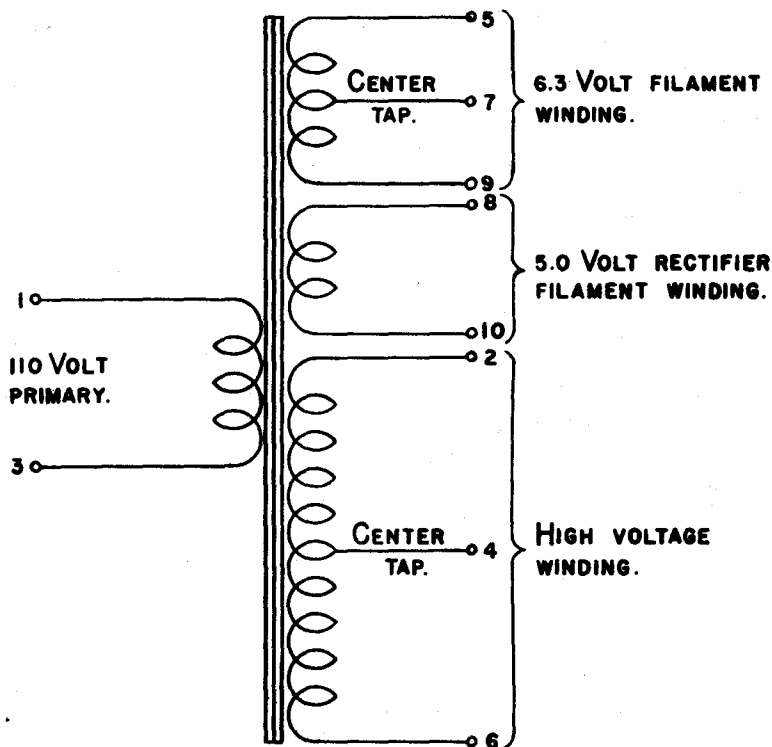

BOTTOM VIEW OF TRANSFORMER.

PURPOSE

A transformer is a device designed to change an A.C. voltage - or a periodically varying D.C. voltage - from one value to another without any change in frequency.

CONSTRUCTION

The ordinary transformer consists of a primary winding - connected to the source of energy - a laminated iron core, and one or more secondary windings. Theoretically, any winding may be used as the primary, provided the proper voltage and frequency be applied to it. The laminated iron core serves as an efficient means of magnetically coupling together the primary and secondary windings.

ACTION

A periodically varying voltage applied to the primary winding produces a varying current that in turn develops a varying flux in the iron core. This varying flux cuts all windings, inducing in each of them a voltage proportional to the number of turns.

TURNS RATIO

The ratio of the primary voltage to any secondary voltage is practically equal to the ratio of the primary turns to the secondary turns as indicated by the formula:

$$\frac{E_p}{E_s} = \frac{N_p}{N_s}$$

ACTION UNDER LOAD

The voltage induced in the primary winding by the growing and dying core flux is practically equal to the applied voltage; moreover, this induced voltage directly opposes the applied voltage; therefore, the current drawn from the supply is small.

When a secondary circuit is completed, current circulates around the iron core in the opposite direction to the primary current, reducing the core flux and the counter voltage of the primary. This action causes the current in the primary to vary in accordance with the secondary load. It is through this action that the transformer automatically adjusts itself to changes in secondary load.

TWO TUBE REGENERATIVE CIRCUIT.

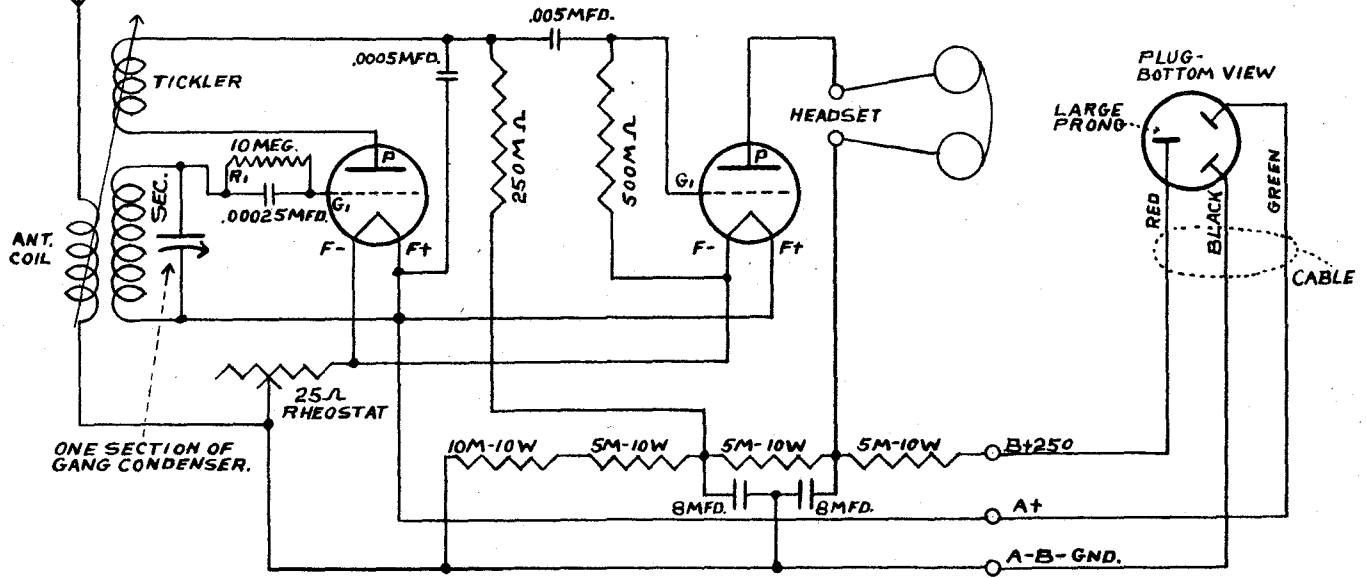

BASE BOARD LAYOUT.
BACK

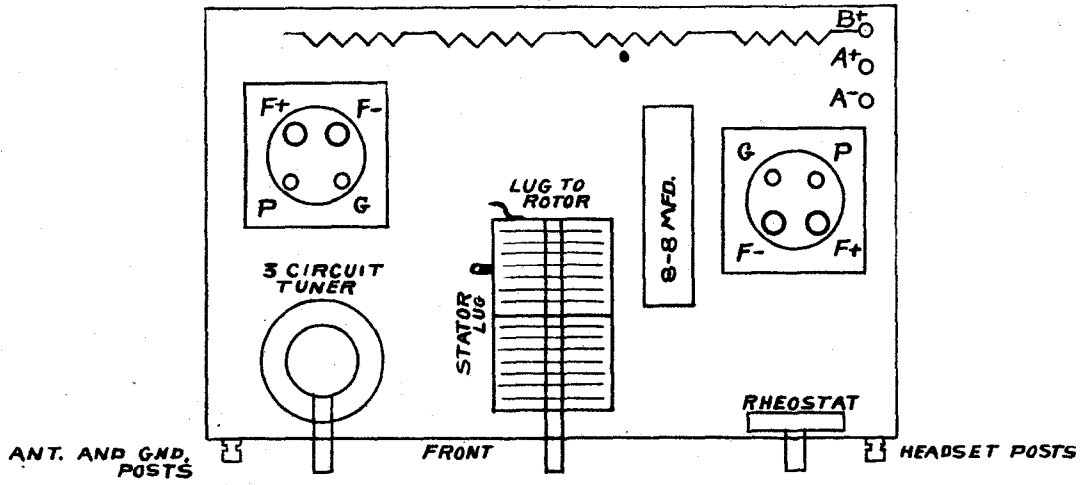

After the set has been wired make the tests indicated on the resistance chart and record the values attained. After resistance chart readings have been checked, put in tubes, apply power, and make readings indicated on voltage chart.

Resistance Chart.

Voltage Chart.

Detector Stage.	F- to A-	F+ to A+	G ₁ to A± <i>R₁ R₂ Norm. Shtd.</i>	P to B+	A+ to A- <i>Rheo on Rheo off.</i>	B+ to A±	Ant. to Gnd.	F+ to F- <i>Rheo on Rheo off.</i>	G ₁ to F-	P to F-
Audio Stage.	F- to A-	F+ to A+	G ₁ to A±	P to B+	A+ to A- <i>Rheo on Rheo off.</i>	B+ to A±		F+ to F- <i>Rheo on Rheo off.</i>		

5 TUBE T.R.F. CIRCUIT

3 GANG CONDENSER

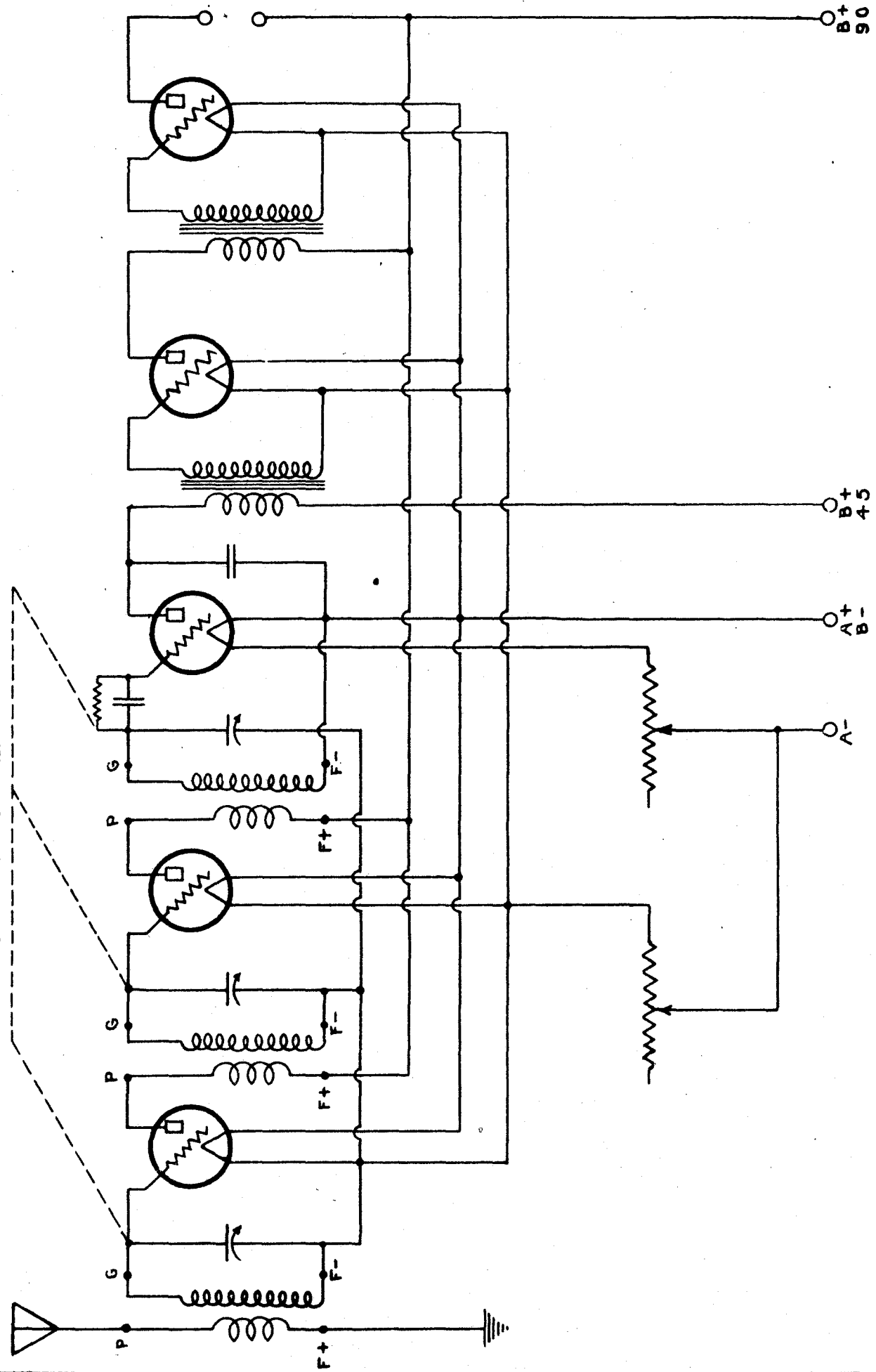

SUPERHETERODYNE RECEIVER.

Radio Receivers and Controls

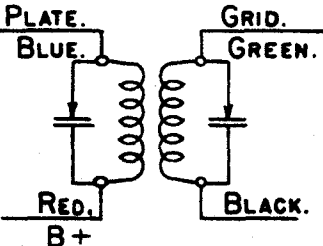
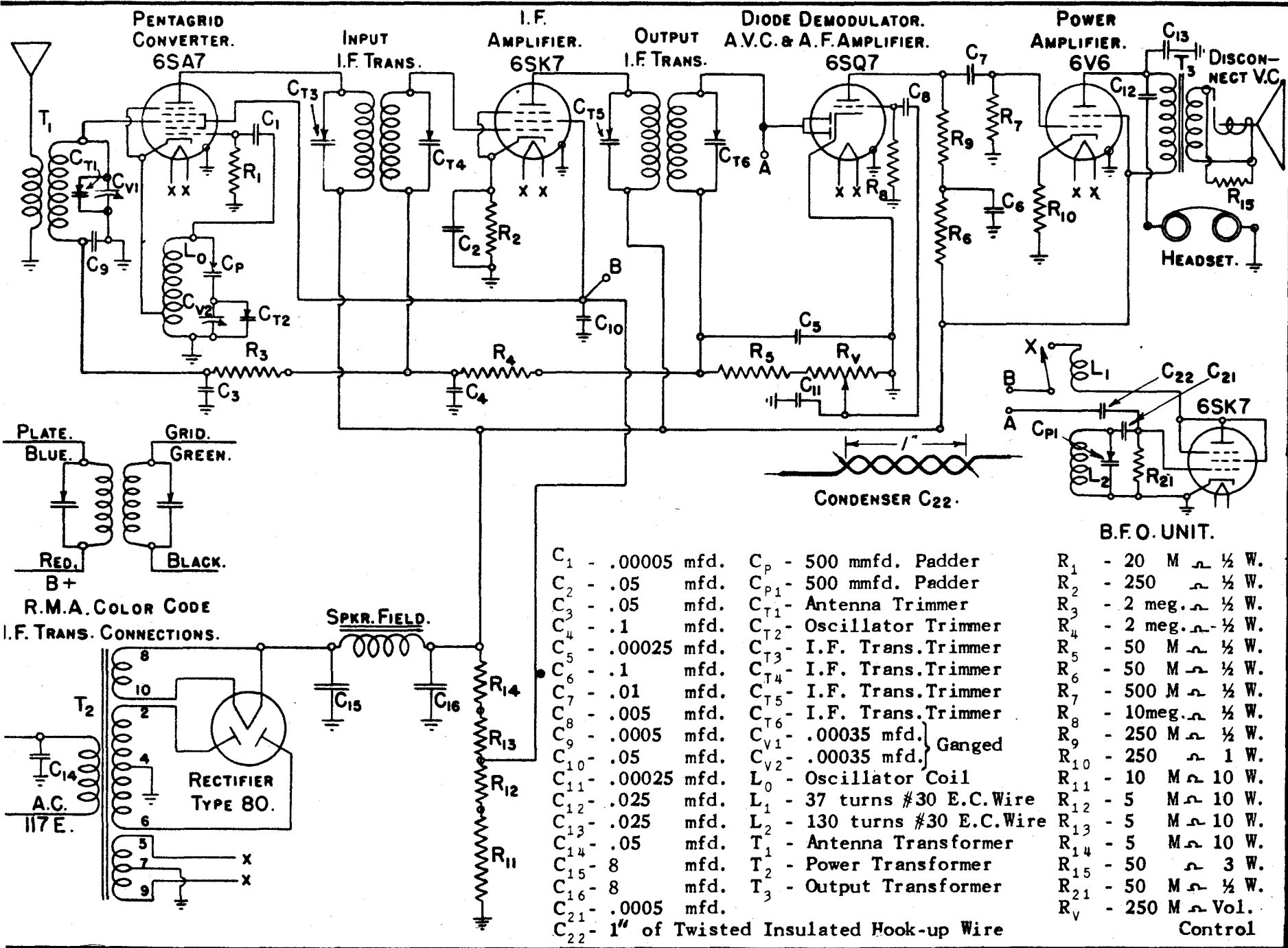

R.M.A. COLOR CODE
I.F. TRANS. CONNECTIONS.

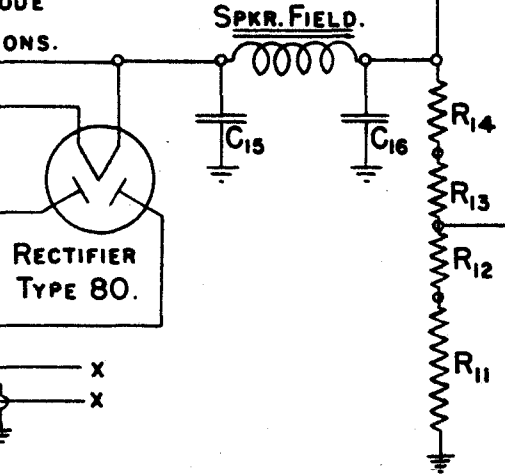
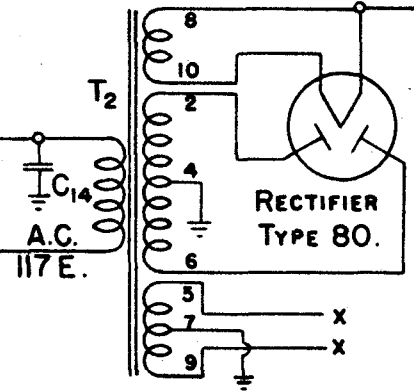

- C₁ - .00005 mfd.
- C₂ - .05 mfd.
- C₃ - .05 mfd.
- C₄ - .1 mfd.
- C₅ - .00025 mfd.
- C₆ - .1 mfd.
- C₇ - .01 mfd.
- C₈ - .005 mfd.
- C₉ - .0005 mfd.
- C₁₀ - .05 mfd.
- C₁₁ - .00025 mfd.
- C₁₂ - .025 mfd.
- C₁₃ - .025 mfd.
- C₁₄ - .05 mfd.
- C₁₅ - 8 mfd.
- C₁₆ - 8 mfd.
- C₂₁ - .0005 mfd.
- C₂₂ - 1" of Twisted Insulated Hook-up Wire

- C_P - 500 mmfd. Padder
- C_{P1} - 500 mmfd. Padder
- C_{T1} - Antenna Trimmer
- C_{T2} - Oscillator Trimmer
- C_{T3} - I.F. Trans. Trimmer
- C_{T4} - I.F. Trans. Trimmer
- C_{T5} - I.F. Trans. Trimmer
- C_{T6} - I.F. Trans. Trimmer
- C_{V1} - .00035 mfd. } Ganged
- C_{V2} - .00035 mfd. }
- L₀ - Oscillator Coil
- L₁ - 37 turns #30 E.C. Wire
- L₂ - 130 turns #30 E.C. Wire
- T₁ - Antenna Transformer
- T₂ - Power Transformer
- T₃ - Output Transformer

- B.F.O. UNIT.**
- R₁ - 20 M Ω ½ W.
 - R₂ - 250 Ω ½ W.
 - R₃ - 2 meg. Ω ½ W.
 - R₄ - 2 meg. Ω ½ W.
 - R₅ - 50 M Ω ½ W.
 - R₆ - 50 M Ω ½ W.
 - R₇ - 500 M Ω ½ W.
 - R₈ - 10 meg. Ω ½ W.
 - R₉ - 250 M Ω ½ W.
 - R₁₀ - 250 Ω 1 W.
 - R₁₁ - 10 M Ω 10 W.
 - R₁₂ - 5 M Ω 10 W.
 - R₁₃ - 5 M Ω 10 W.
 - R₁₄ - 5 M Ω 10 W.
 - R₁₅ - 50 Ω 3 W.
 - R₂₁ - 50 M Ω ½ W.
 - R_V - 250 M Ω Vol. Control

MECHANICAL LAYOUT FOR SUPERHETERODYNE.

UNDERSIDE VIEW OF CHASSIS.

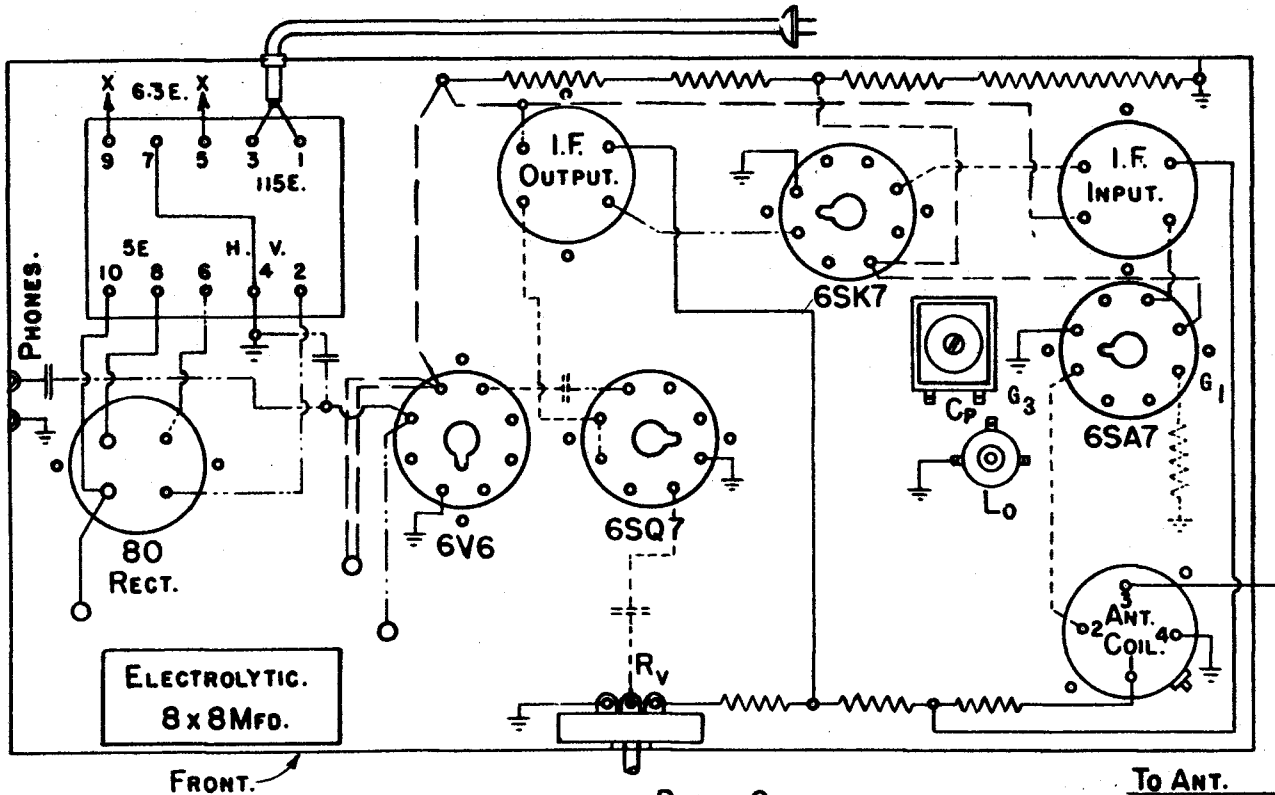

- PLATE CIRCUIT.
- - - - - SCREEN GRID OR D.C. VOLTAGE CIRCUIT.
- CONTROL GRID OR DIODE CIRCUITS.

ALIGNING PRECAUTIONS

- 1.-Always use an insulated screwdriver when adjusting I. F. trimmers.
- 2.-Always use both headsets and output meter as indicators. V.C. must be disconnected.
- 3.-Keep volume control of receiver full on.
- 4.-**BE SURE** to connect grounded lead of generator to the chassis.
- 5.-Keep attenuator and multiplier of signal generator turned down to the point at which signal is just strong enough to give an indication.
- 6.-**BE SURE** to make adjustments in proper sequence as given in table below.

Step No.	OPERATIONS		Connect Ungrounded lead of Signal Generator to	Set Receiver Dial to	Set Signal Generator to	Type of Signal	Adjust Cond. to obtain maximum indication	
							1st	2nd
1	Aligning I. F. Output Trans.	Short	G ₁ of 6SK7	600 KC	455 KC	Mod. IF	C _{T6}	C _{T5}
2	Aligning I. F. Input Trans.	Osc.	G ₃ of 6SA7'	600 KC	455 KC	Mod. IF	C _{T4}	C _{T3}
3	Check I. F. Alignment	Coil	G ₃ of 6SA7	600 KC	455 KC	Mod. IF	C _{T6} C _{T5}	C _{T4} C _{T3}
4	Aligning at high Freq. end of dial	Remove Osc.	Antenna Lead	1400 KC	1400 KC	Mod. RF	C _{T2}	C _{T1}
5	Aligning at low Freq. end of dial		Antenna Lead	600 KC	600 KC	Mod. RF	C _P	
6	Re-align at high Freq. end of dial	Coil Short	Antenna Lead	1400 KC	1400 KC	Mod. RF	C _{T2}	C _{T1}
7	Re-align at low Freq. end of dial		Antenna Lead	600 KC	600 KC	Mod. RF	C _P	
8	Final Checking	REPEAT ENTIRE PROCESS						

SUPER-HETERODYNE PRINCIPLES

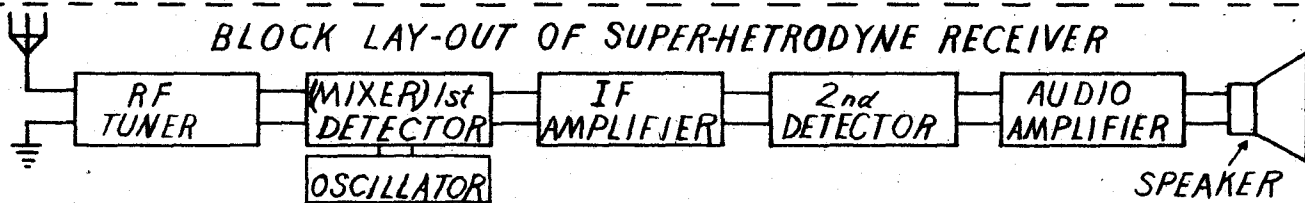
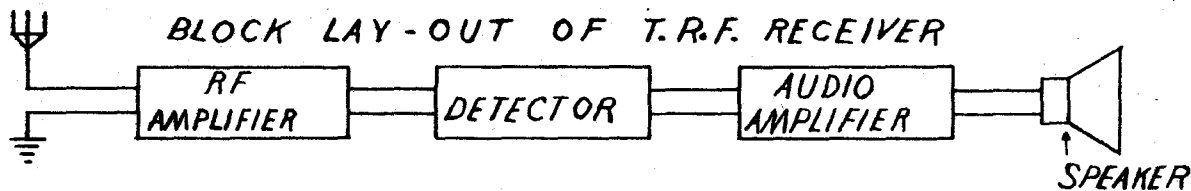

FIG. 1. MIXING TWO FREQUENCIES TOGETHER PRODUCES IF

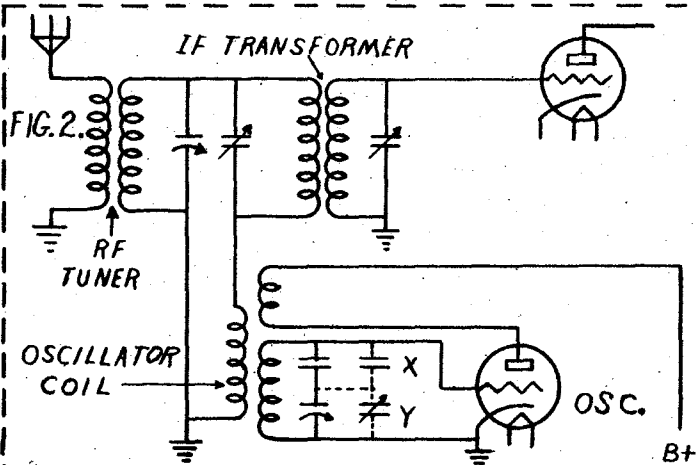
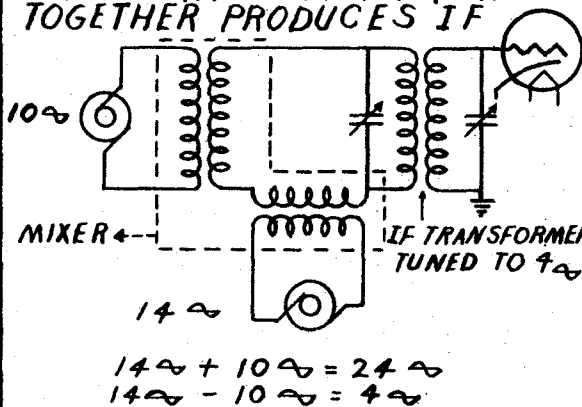

FIG. 3. ELECTRON COUPLED DETECTOR - OSCILLATOR

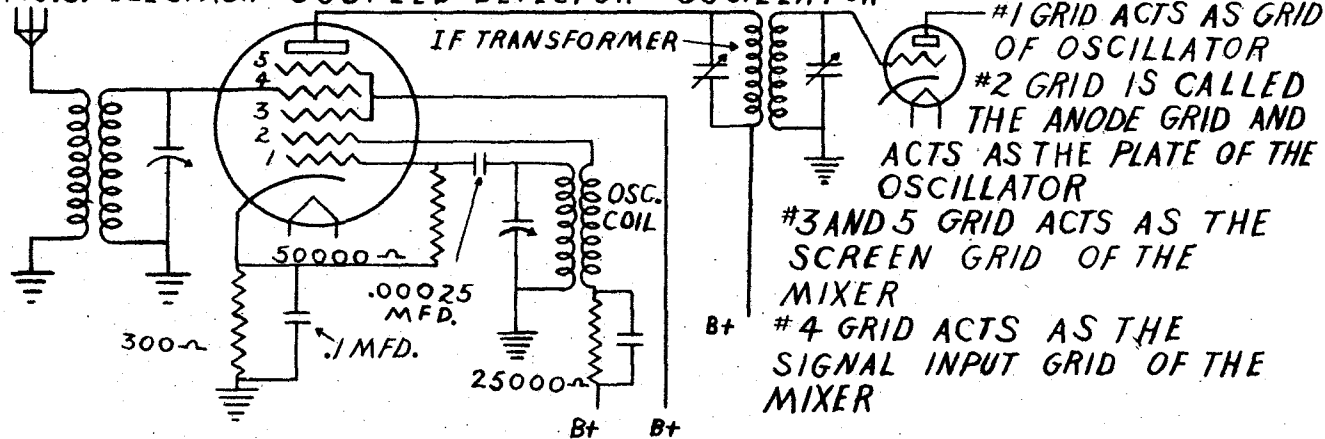

FIG. 4. SOUND CHANNEL MAKE-UP
 SHARP TUNING RANGE UP TO 5000 C.P.S.
 BROAD TUNING HIGH FIDELITY AUDIO RANGE UP TO 7500 C.P.S.

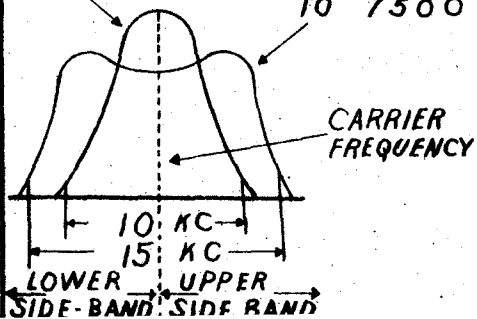
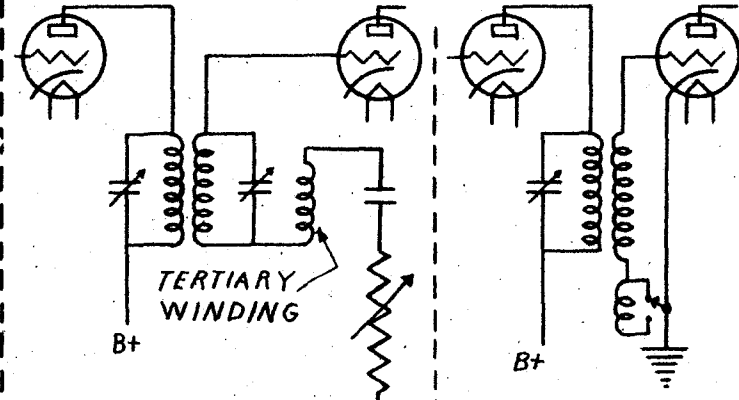
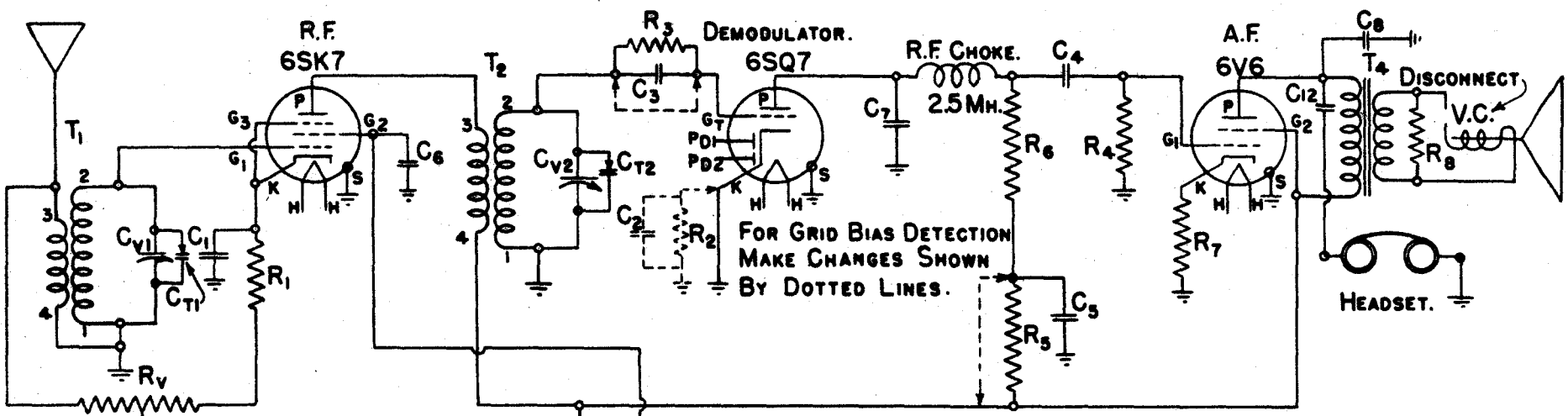
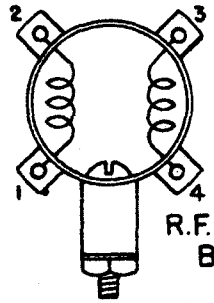

FIG. 5. HIGH FIDELITY IF TRANSFORMERS





FOR GRID BIAS DETECTION
MAKE CHANGES SHOWN
BY DOTTED LINES.



4 ANT. AND
R.F. TRANSFORMER. (T₁ & T₂)
BASE VIEW.

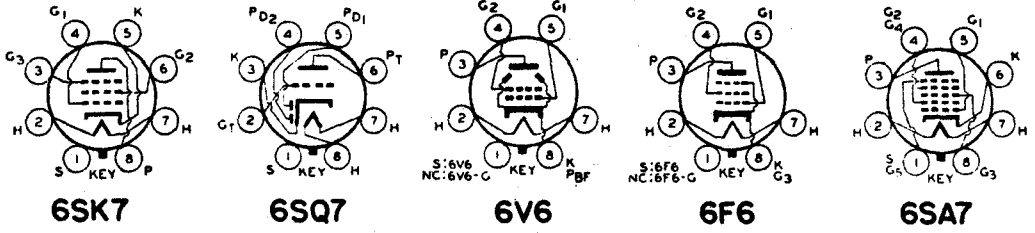
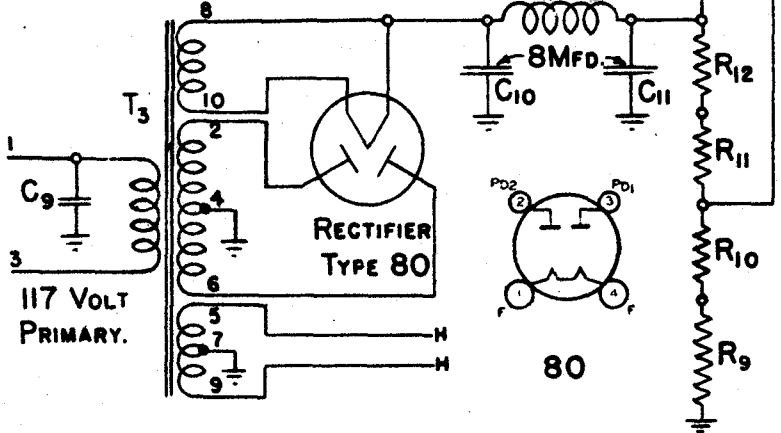

- | | | | | | |
|-----------------|---------|--------------------------|-----------------|-------|---------------------|
| C ₁ | - .1 | mfd. Tubular | R _V | - 10 | M-Ω Vol. Control |
| C ₂ | - .1 | mfd. Tubular | R ₁ | - 300 | Ω ½ W. |
| C ₃ | - .005 | mfd. Tubular | R ₂ | - 25 | M Ω ½ W. |
| C ₄ | - .01 | mfd. Tubular | R ₃ | - 500 | M Ω ½ W. |
| C ₅ | - .1 | mfd. Tubular | R ₄ | - 500 | M Ω ½ W. |
| C ₆ | - .05 | mfd. Tubular | R ₅ | - 20 | M Ω ½ W. |
| C ₇ | - .0005 | mfd. Mica | R ₆ | - 500 | M Ω ½ W. |
| C ₈ | - .025 | mfd. Tubular | R ₇ | - 250 | Ω 1 W. |
| C ₉ | - .05 | mfd. Tubular | R ₈ | - 50 | Ω 3 W. |
| C ₁₀ | - 8 | mfd. Electrolytic | R ₉ | - 10 | M-Ω 10 W. |
| C ₁₁ | - 8 | mfd. Electrolytic | R ₁₀ | - 5 | M-Ω 10 W. |
| C ₁₂ | - .025 | mfd. Tubular | R ₁₁ | - 5 | M-Ω 10 W. |
| C _{T1} | - | Trimmer Condenser (Ant.) | R ₁₂ | - | M-Ω 10 W. |
| C _{T2} | - | Trimmer Condenser (R.F.) | T ₁ | - | Antenna Transformer |
| C _{V1} | - | Tuning Condenser | T ₂ | - | R.F. Transformer |
| C _{V2} | - | Tuning Condenser | T ₃ | - | Power Transformer |
| | | | T ₄ | - | Output Transformer |

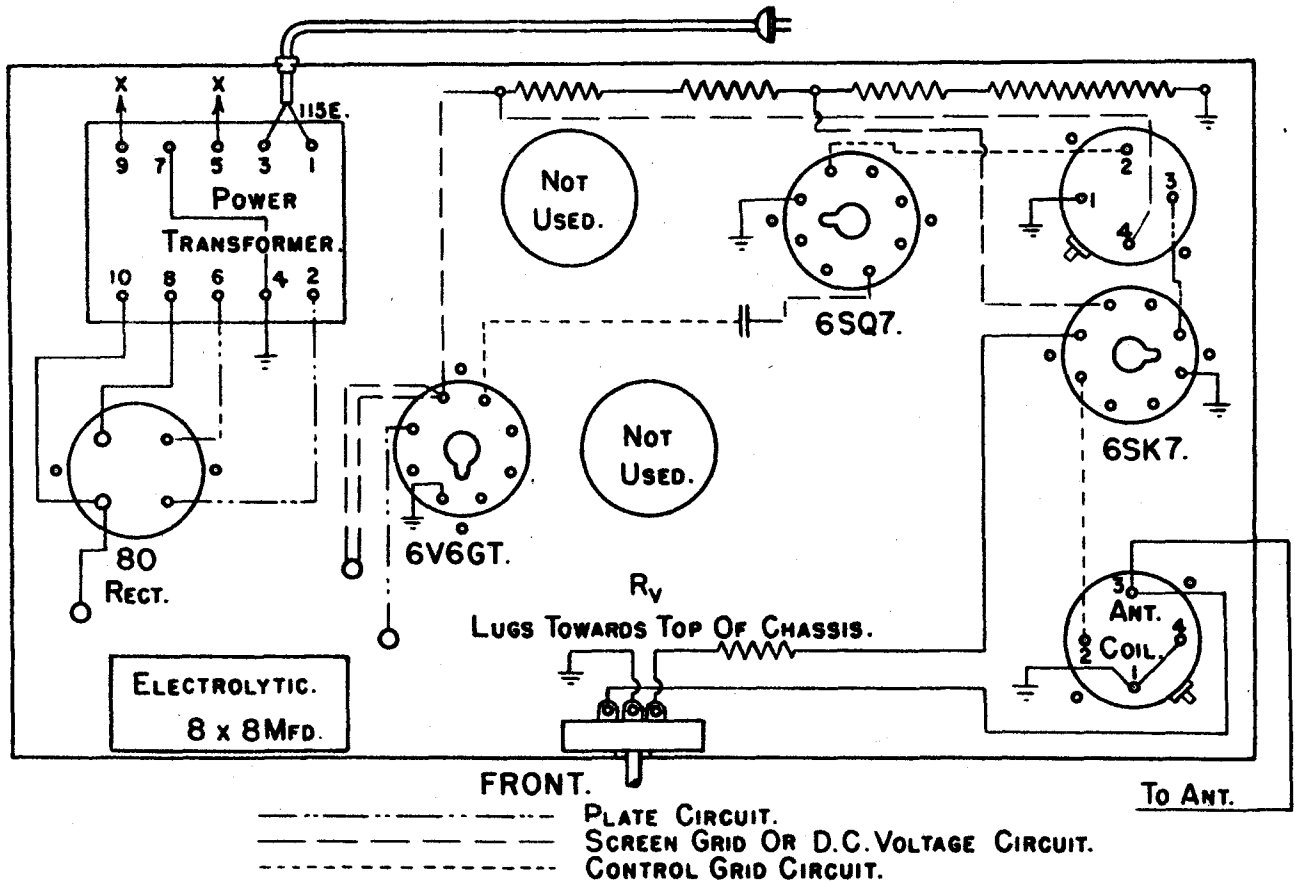
MECHANICAL LAYOUT FOR T.R.F. RECEIVER.**UNDERSIDE VIEW OF CHASSIS.****PRECAUTIONS & CONSTRUCTION PROCEDURE**

1. Keep all parts in kit box until you are ready to mount them. This will prevent loss and breakage.
2. Keep plates of tuning condenser fully meshed, except when tuning.
3. Do not short C_v by using excessive solder when soldering to stator lugs. If it is necessary to remove surplus solder from lugs, hold C_v with lugs pointing down and run solder off. C_{v1} and C_{v2} are ganged on one shaft.
4. Mount fibre plates on antenna and R. F. coils correctly.
5. Always use headsets -- V.C. must not be connected. Resistor must replace V.C.
6. In antenna and R.F. coils with high impedance primary, the ohmic R of the primary winding will be higher than the ohmic R of the secondary winding.
7. Connect outside foil end of tubular condenser to chassis, if used for bypass; to plate if used for coupling.
8. Before applying power to the set, **BE SURE** the job has been checked by an instructor and your job card has been punched. Violation will earn demerits.
9. Arrange sockets so that grid and plate wires will be short as possible. Refer to socket layout.
10. Run wires straight using right angle bends. Keep G_1 and P wires away from each other and from all other wires to prevent coupling. Keep all wires close to the chassis except G_1 wires which should be one-fourth inch away.
11. Never solder to a nut, screw, or chassis; always use a soldering lug.
12. Wire all heater circuits in parallel twisting the heater wires.
13. Connect circuit wires by wiring one circuit at a time. As each wire is inserted, score the line on the schematic diagram using same color pencil as used in diagram tracing. Order of wiring circuits is: 1st, heater; 2nd, cathode and suppressor grid; 3rd, screen grid; 4th, antenna; 5th, plate; and 6th, control grid.

THREE BAND RECEIVER.

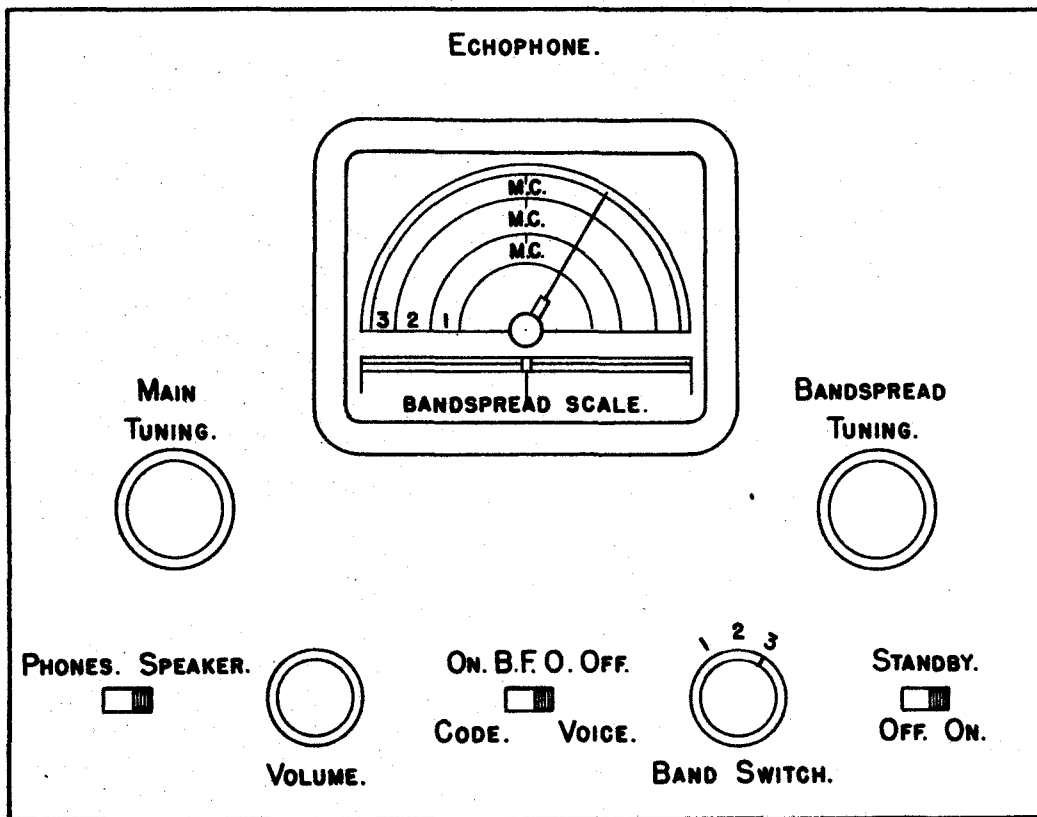
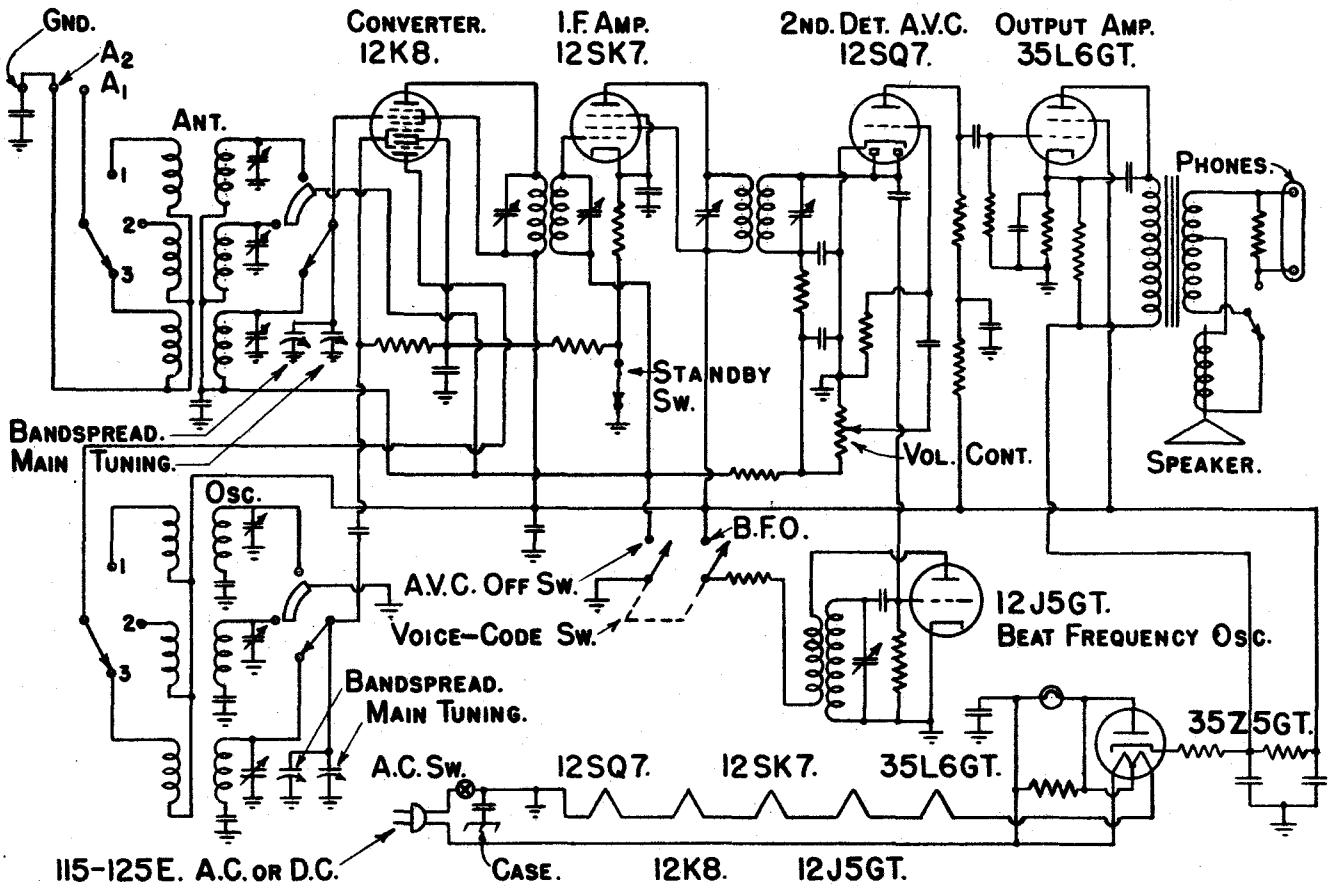

RADIO TRANSCEIVER 2.5 METERS.

CONSTRUCTION

A Transceiver is a combination of transmitter and receiver designed for both transmission and reception. The apparatus is usually enclosed in a metal case and provided with a self contained battery power supply.

OPERATION

RECEIVER

When the control switch is in the receive position, the unit uses the type 6J5GT tube as a super-regenerative detector. The type 6G6G is used as an audio amplifier to increase the volume of the received signal.

TRANSMITTER

When the control switch is in the transmit position, the unit operates as a transmitter, the 6F5GT functioning as a modulated oscillator using the class "A" Heising system of modulation. The power developed by this tube and circuit is fed to the antenna.

When operating as a transmitter the 6G6G tube functions as a modulated using the class "A" Heising system of modulation.

When transmitting, the antenna circuit is set for maximum output by adjusting the length of the telescopic antenna until the antenna bulb that is used as a current indicator shows maximum brilliancy.

The percentage of modulation, of the volume of the received signal, is varied by the volume control.

The frequency of this transceiver is 112 to 116 megacycles. The distance range varies from 3 to 30 miles depending upon the nature of the terrain and the elevation.

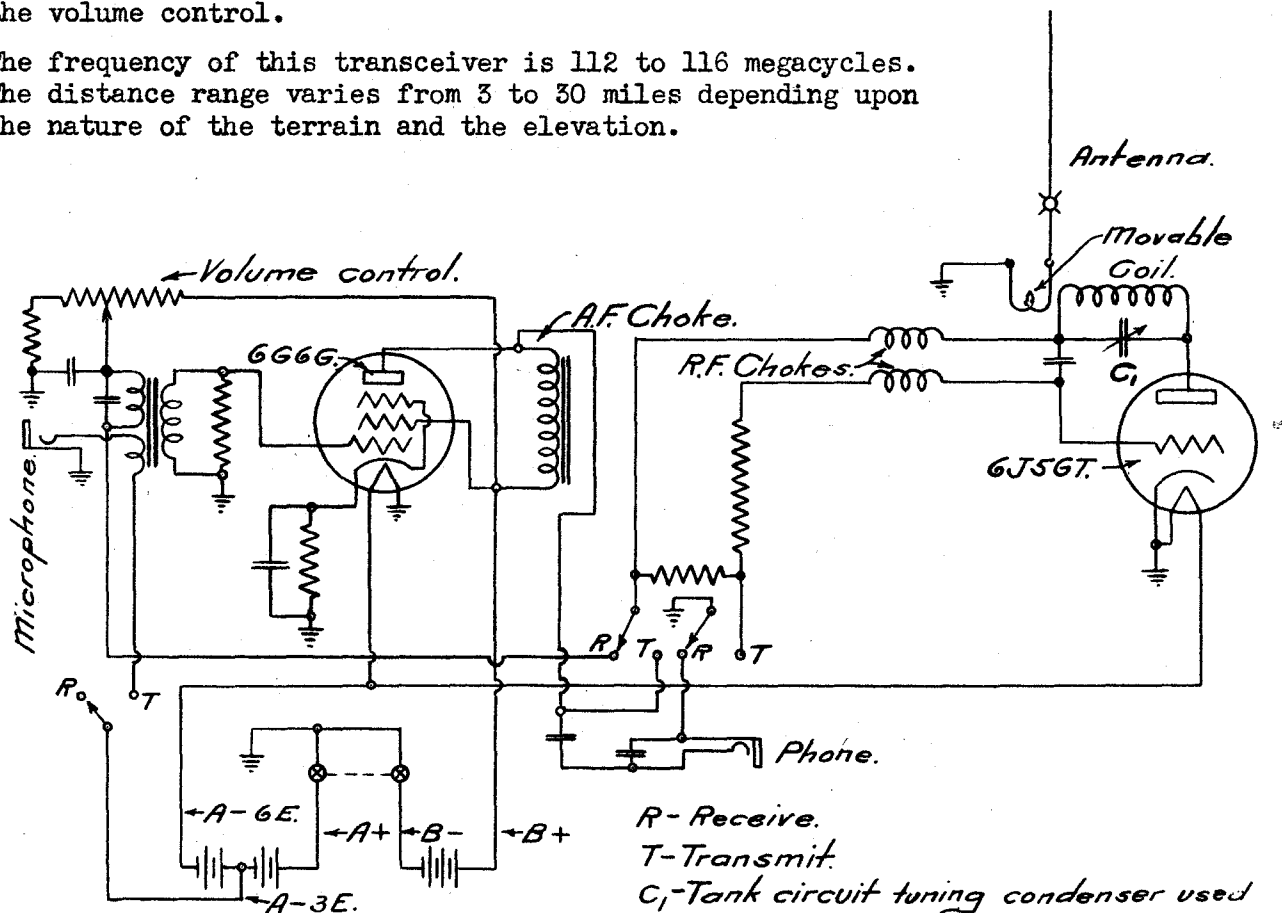

Coupling between tank circuit and antenna is varied by movable antenna coil.

SERVICE

FREQUENCY MODULATION

A COMPARISON OF F-M AND A-M

FREQUENCY MODULATION IS A NEW METHOD OF USING A RADIO WAVE TO TRANSMIT A MESSAGE. SINCE IT IS ESSENTIALLY A DIFFERENT METHOD OF MODULATION, A CORRESPONDINGLY DIFFERENT METHOD OF DEMODULATION OR DETECTION MUST BE USED AT THE RECEIVER IN ORDER TO ENABLE THE RECOVERY OF THE ORIGINAL MESSAGE. THIS MESSAGE MAY BE SPEECH, MUSIC, FACSIMILE, TELEVISION OR ANY OTHER INTELLIGENCE WHICH CAN BE CONVERTED INTO AN ELECTRICAL SIGNAL.

①

THE CARRIER SIGNAL

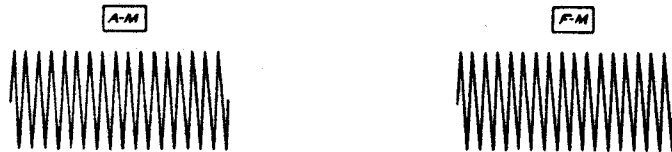

THE CARRIER WAVES ARE IDENTICALLY THE SAME FOR BOTH F-M AND A-M TRANSMISSIONS. THERE IS NO DIFFERENCE WHATSOEVER BETWEEN AN F-M AND A-M SIGNAL WHEN NEITHER OF THE SIGNALS IS MODULATED.

②

THE AUDIO OR MODULATING SIGNAL

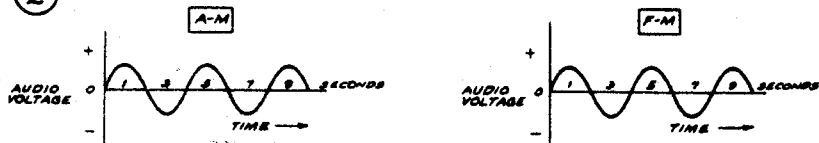

⑥

THE LIMITER STAGE

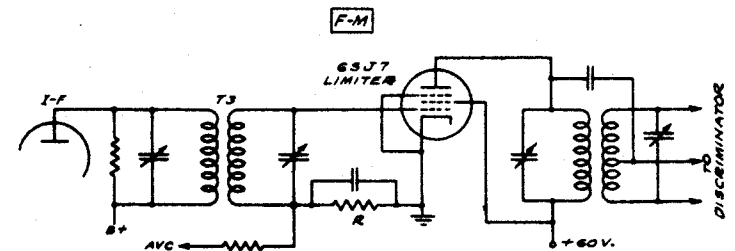

THE LIMITER STAGE IS USED IN F-M RECEIVERS TO REMOVE VARIATIONS IN AMPLITUDE OF THE FREQUENCY-MODULATED WAVE. LOW PLATE AND SCREEN VOLTAGES ARE EMPLOYED SO THAT THE LIMITER OVERLOADS EVEN WHEN THE INPUT SIGNAL IS WEAK. THE OUTPUT FED TO THE DISCRIMINATOR IS THEREBY MAINTAINED CONSTANT REGARDLESS OF VARIATIONS IN THE STRENGTH OF THE INCOMING SIGNAL DUE TO NOISE OR OTHER CAUSES. THE LIMITER IS NOT USED IN A-M RECEIVERS.

⑦

HOW THE LIMITER WORKS

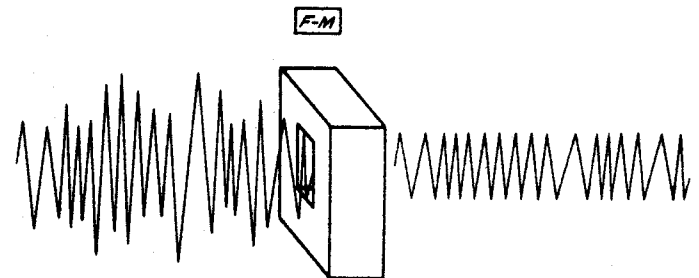

THIS FIGURE SHOWS IN PICTORIAL FORM HOW THE LIMITER FUNCTIONS TO SMOOTH OUT THE AMPLITUDE VARIATIONS IN THE FREQUENCY MODULATED SIGNAL.

EFFECT OF SIGNAL ON THE CARRIER

3

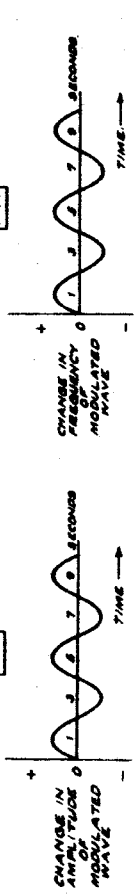

IN AMPLITUDE-MODULATION, THE AUDIO SIGNAL CAUSES THE AMPLITUDE OF THE MODULATED WAVE TO VARY IN ACCORDANCE WITH THE AUDIO (MODULATING) VOLTAGE.

IN FREQUENCY-MODULATION, THE AUDIO SIGNAL CAUSES THE FREQUENCY OF THE MODULATED WAVE TO VARY IN ACCORDANCE WITH THE AUDIO (MODULATING) VOLTAGE.

THE SIGNAL AFTER MODULATION. THE MODULATED WAVE

4

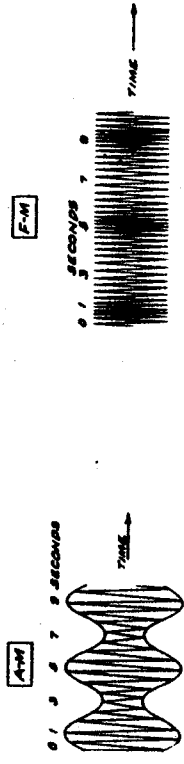

IN AMPLITUDE-MODULATION, THE AMPLITUDE OF THE MODULATED WAVE VARIES SINUSOIDALLY IN ACCORDANCE WITH THE AUDIO (MODULATING) VOLTAGE. THE FREQUENCY OF THE WAVE IS NOT SHIFTED.

IN FREQUENCY-MODULATION, THE FREQUENCY OF THE WAVE IS SHIFTED SINUSOIDALLY IN ACCORDANCE WITH THE AUDIO (MODULATING) VOLTAGE. THE AMPLITUDE OF THE WAVE REMAINS CONSTANT.

HOW THE SIGNAL IS MODULATED

5

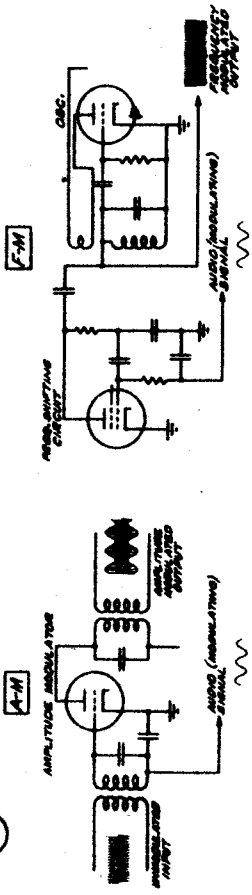

A TYPICAL METHOD OF AMPLITUDE MODULATION IN WHICH THE MODULATING VOLTAGE IS FED TO THE GRID OF THE MODULATOR TUBE.

A TYPICAL METHOD OF FREQUENCY MODULATION IN WHICH THE MODULATING VOLTAGE IS FED TO THE CONTROL GRID OF THE MODULATOR TUBE.

A-M DETECTOR

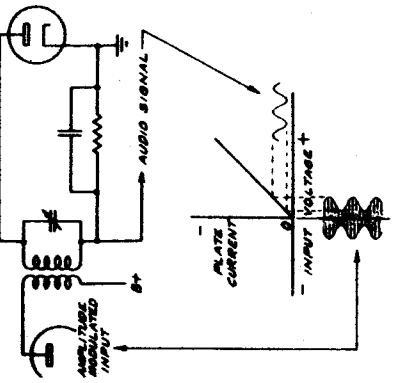

THE AMPLITUDE-MODULATION DETECTOR CONVERTS THE VARIATIONS IN AMPLITUDE OF THE MODULATED WAVE INTO THE ORIGINAL AUDIO SIGNAL. THE CHARACTERISTIC OF THE DETECTOR CIRCUIT WHICH ACCOMPLISHES THIS IS SHOWN ABOVE.

F-M DETECTOR (DISCRIMINATOR)

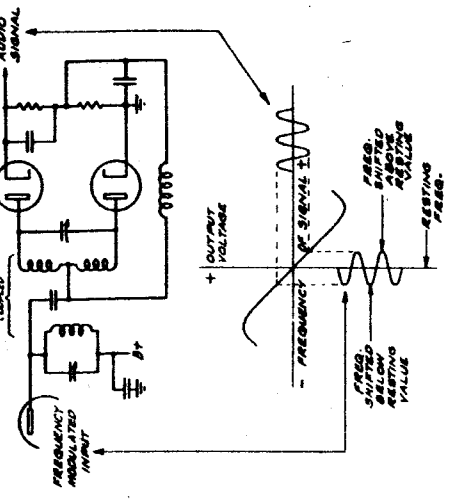

THE FREQUENCY-MODULATION DETECTOR CONVERTS THE VARIATIONS IN FREQUENCY OF THE MODULATED WAVE INTO THE ORIGINAL AUDIO SIGNAL. THE CHARACTERISTIC OF THE DISCRIMINATOR CIRCUIT WHICH ACCOMPLISHES THIS IS SHOWN ABOVE.

9

SIDE BANDS & BANDWIDTH

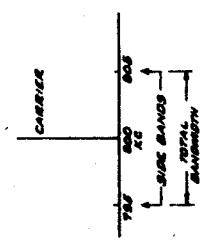
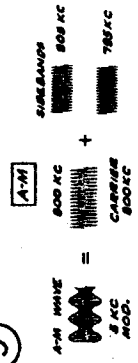

AN AM WAVE IS COMPOSED OF A CARRIER & BANDWIDTH IS THE CHANNEL SPACE REQUIRED BY AN AM WAVE IS EQUAL TO THREE TIMES THE HIGHEST AUDIO FREQUENCY. SINCE THE HIGHEST AUDIO FREQUENCY TRANSMITTED IS 5 KC, THE REQUIRED BANDWIDTH IS 15 KC.

AN FM WAVE IS COMPOSED OF A CARRIER AND MANY SETS OF SIDE BANDS WHICH BECOME PROGRESSIVELY WEAKER AS THEIR FREQUENCY DEVIATES MORE FROM THE CARRIER FREQUENCY. SINCE THE BANDWIDTH IS APPROXIMATELY EQUAL TO THREE TIMES THE MAXIMUM FREQUENCY SHIFT OF THE MODULATED WAVE, THE REQUIRED BANDWIDTH IS 15 KC.

AUTOMATIC FREQUENCY CONTROL-A.F.C.

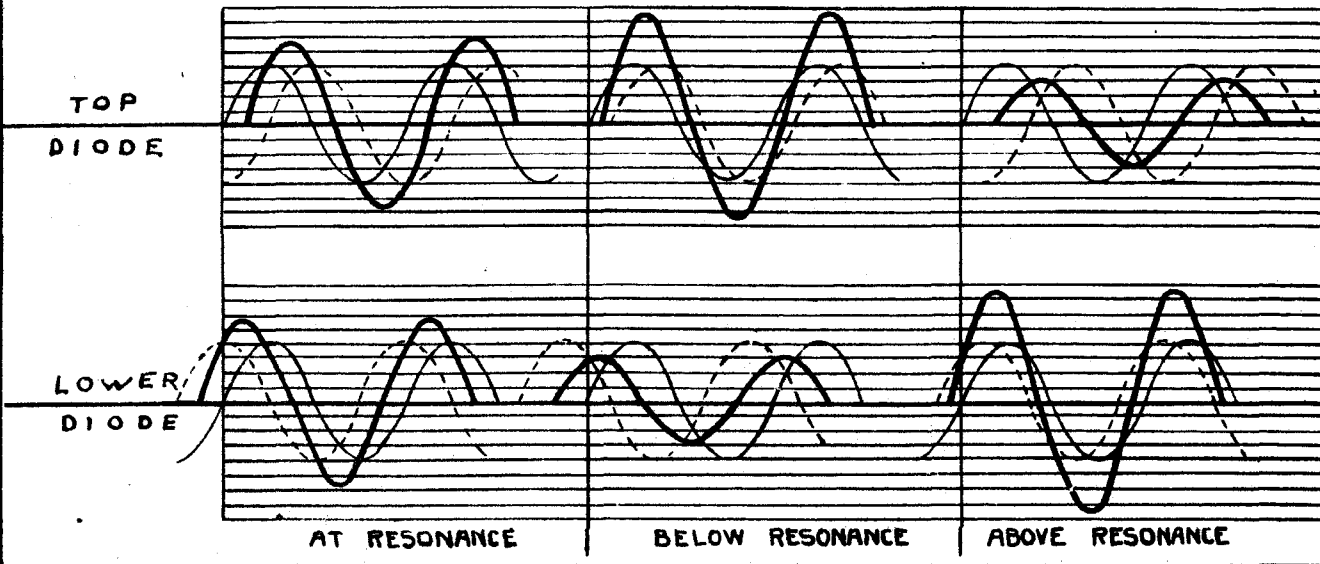
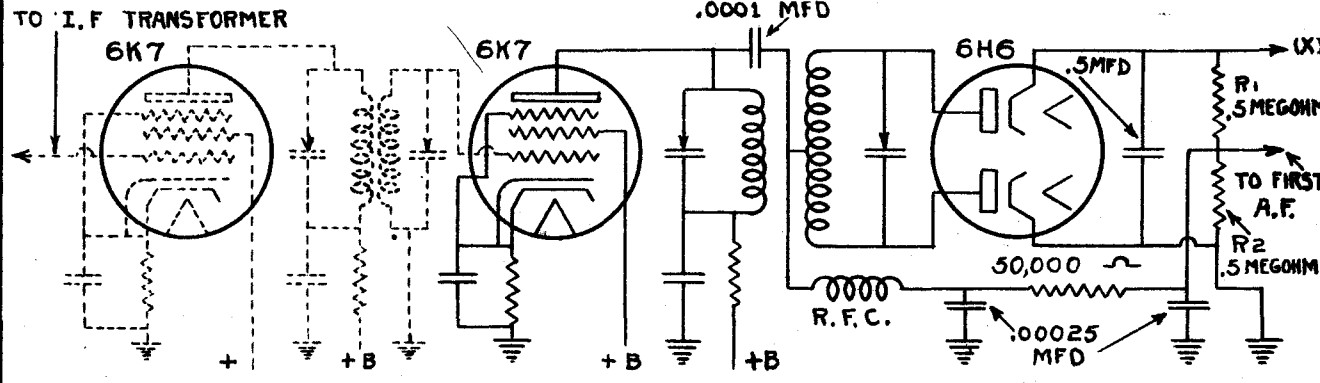
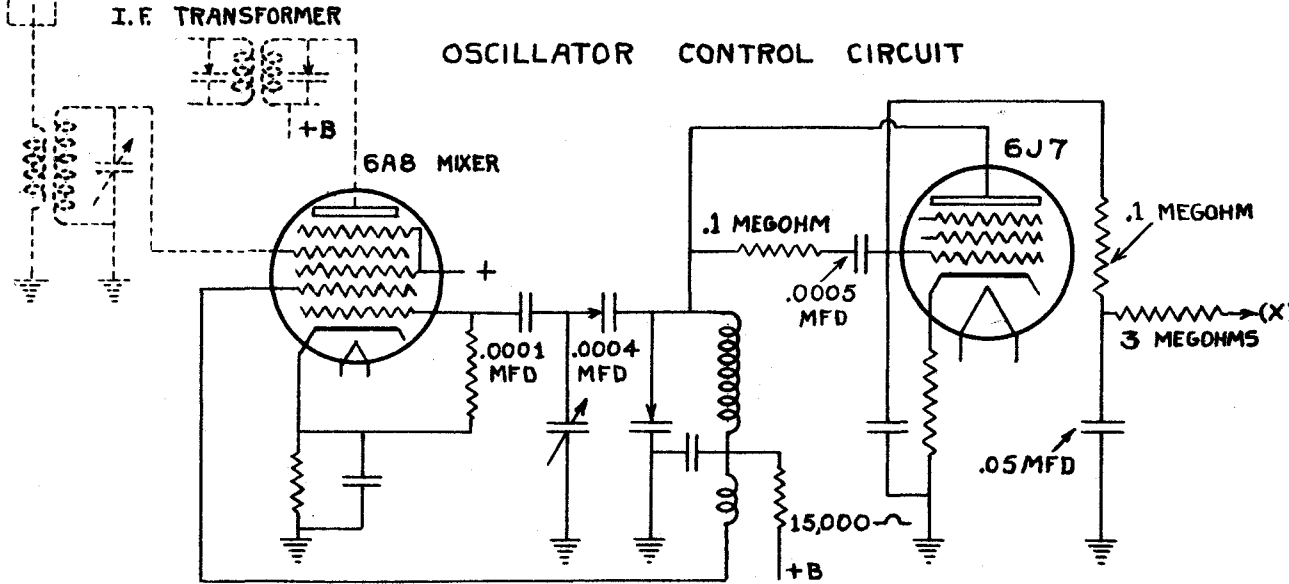
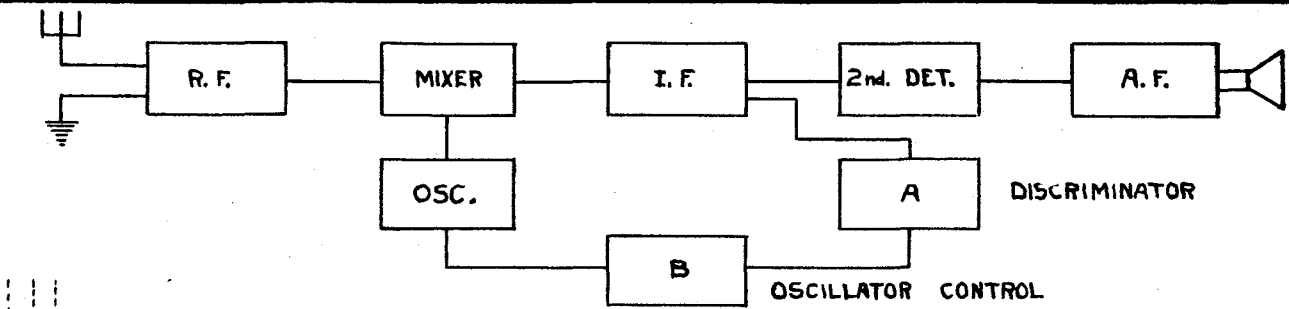

AUTOMATIC VOLUME CONTROL (A.V.C.) AND DIODE DETECTOR CIRCUITS

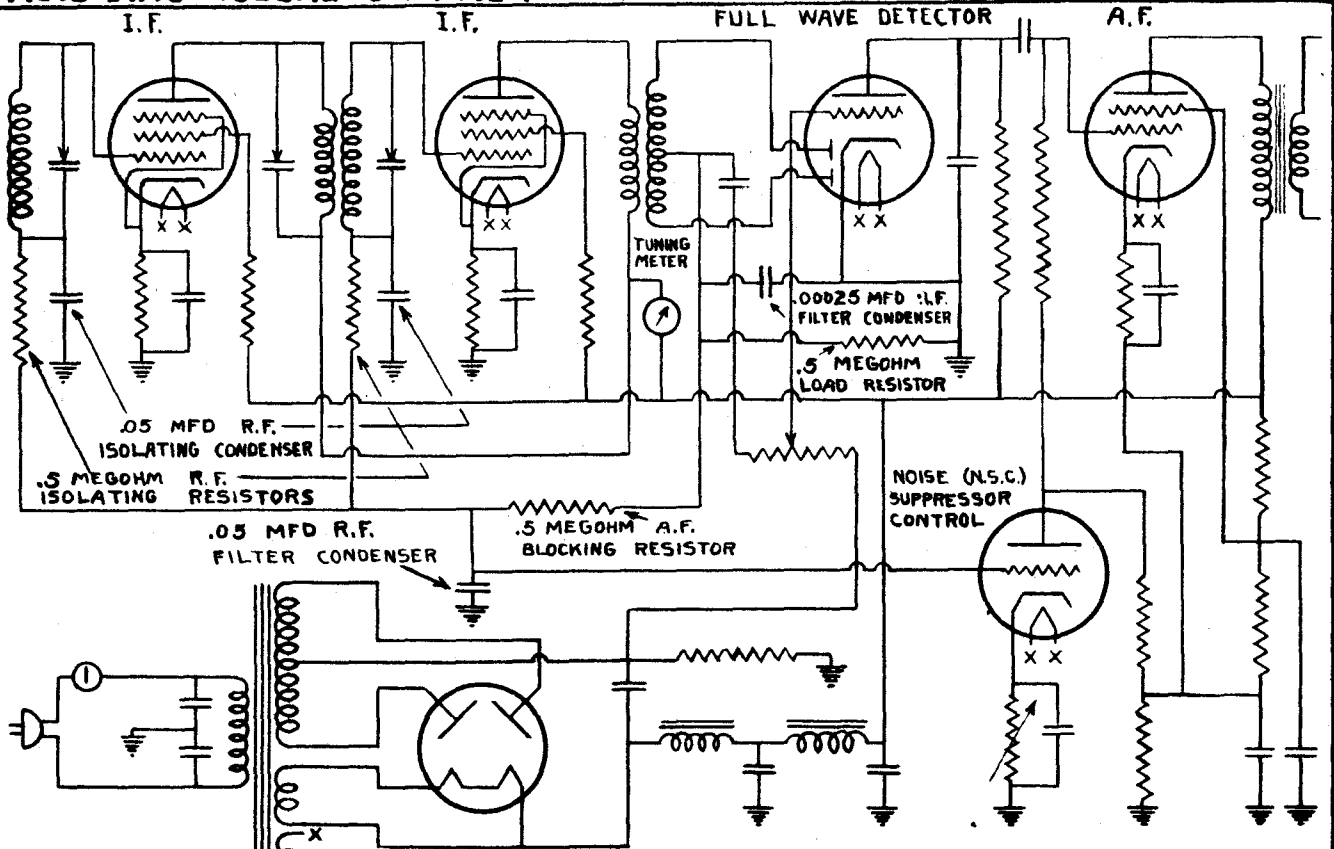

MODULATED BY A.F.

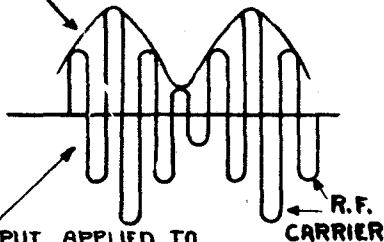

INPUT APPLIED TO DIODE DETECTOR

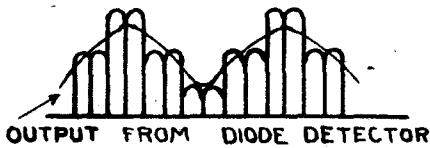

DUO-DIODE-TRIODE TYPE TUBE HALF WAVE DETECTOR 55-75-85-ETC

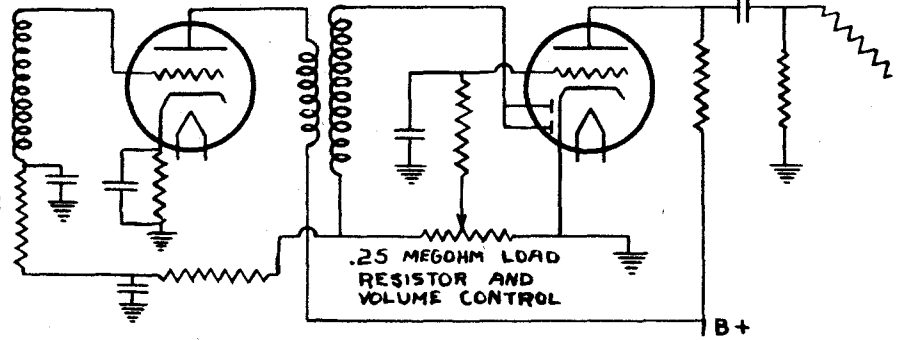

MAGIC EYE

DELAYED A.V.C.

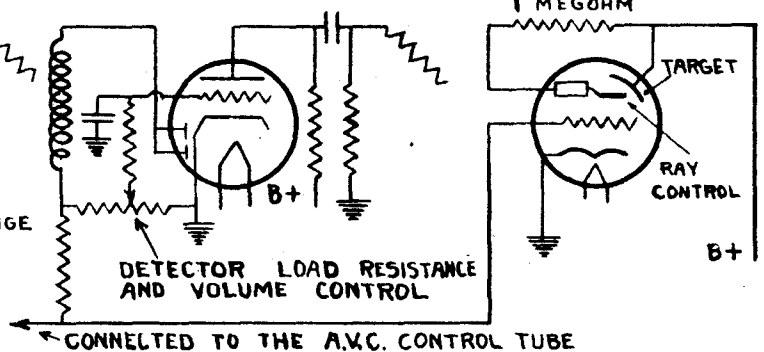
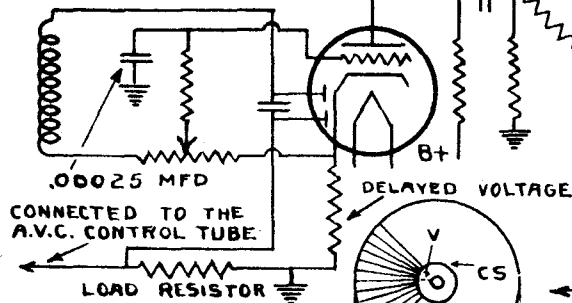

- K- CATHODE
- G- TRIODE GRID
- P- TRIODE PLATE
- V- RAY-CONTROL VANE
- T- FLUORESCENT TARGET
- CS- CATHODE SHIELD

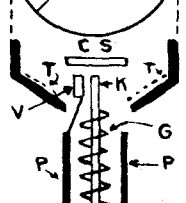

ZERO GRID BIAS,
MINIMUM SIGNAL

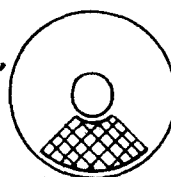

NEGATIVE GRID BIAS,
MAXIMUM SIGNAL

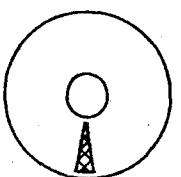

AUTOMATIC TUNING

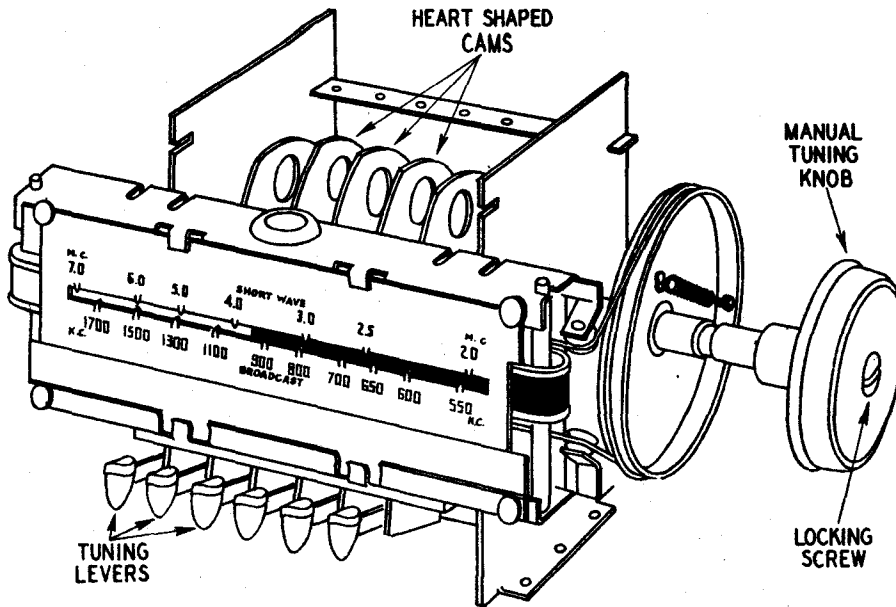
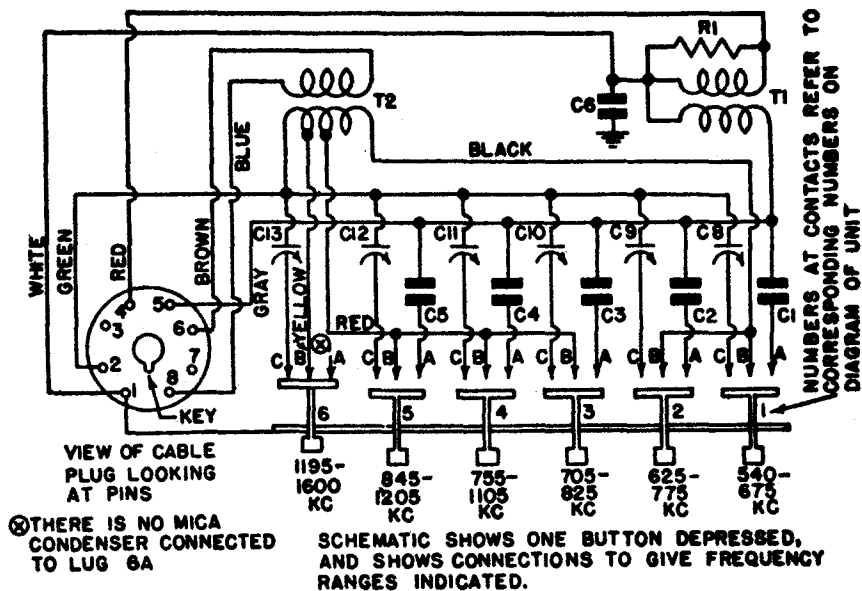
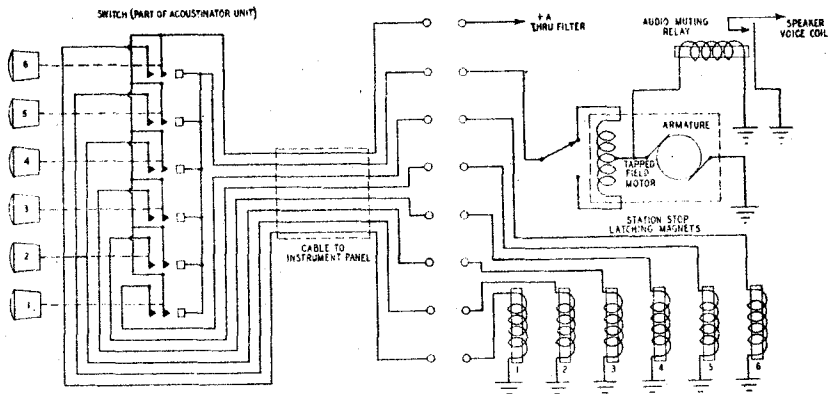

FIG. 1—Belmont "Belmonitor" Tuning System—Front View



EMERSON MIRACLE TUNING UNIT



—Galvin (Motorola) "Press-Button Tuning"—Circuit Diagram

AUTOMATIC TUNING

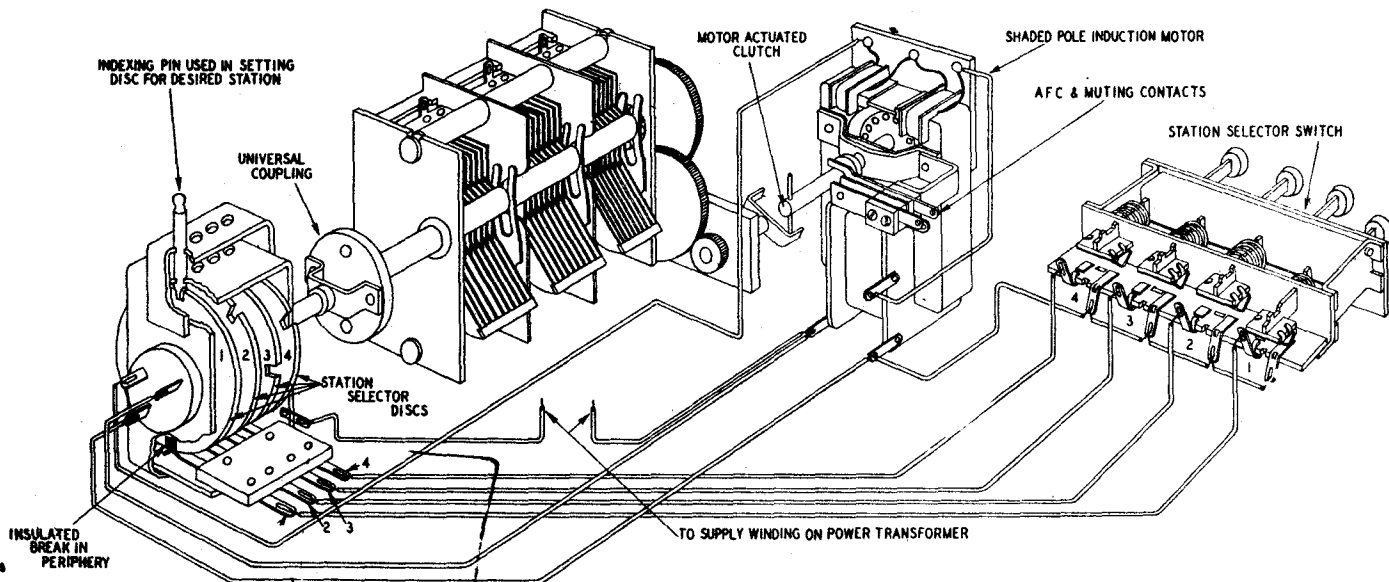

Fig. 31—Typical Motor-Tuned Automatic Station Selector System

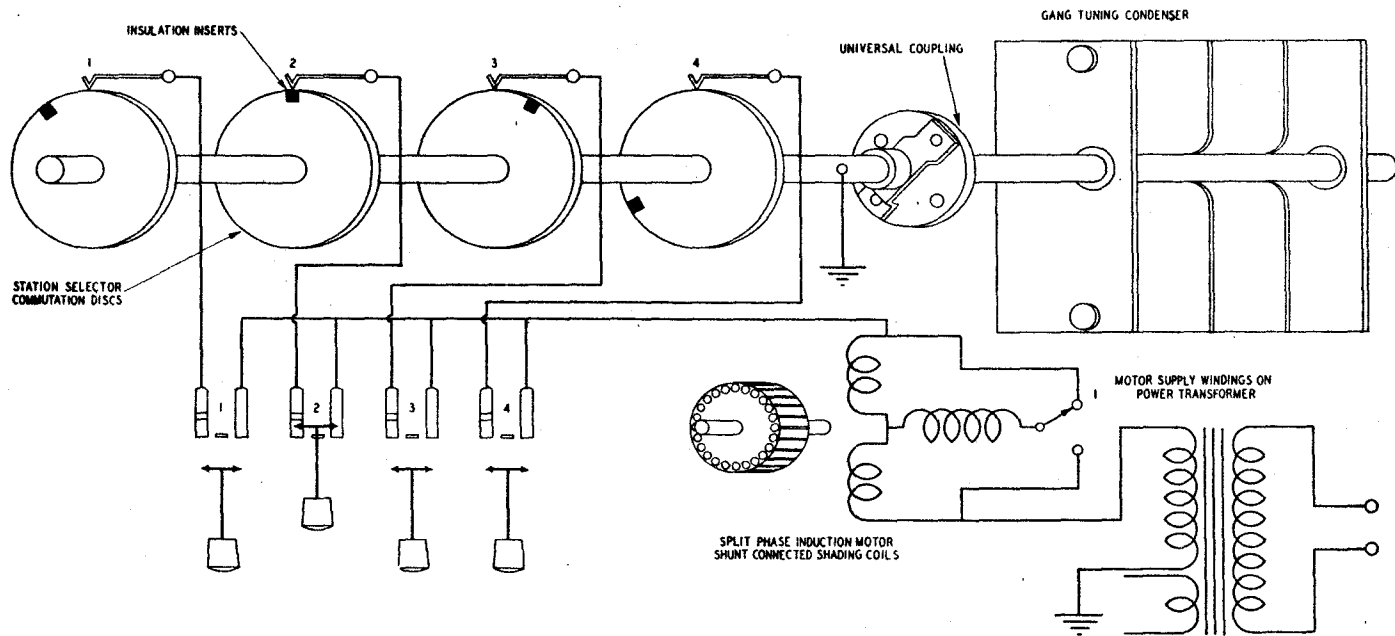
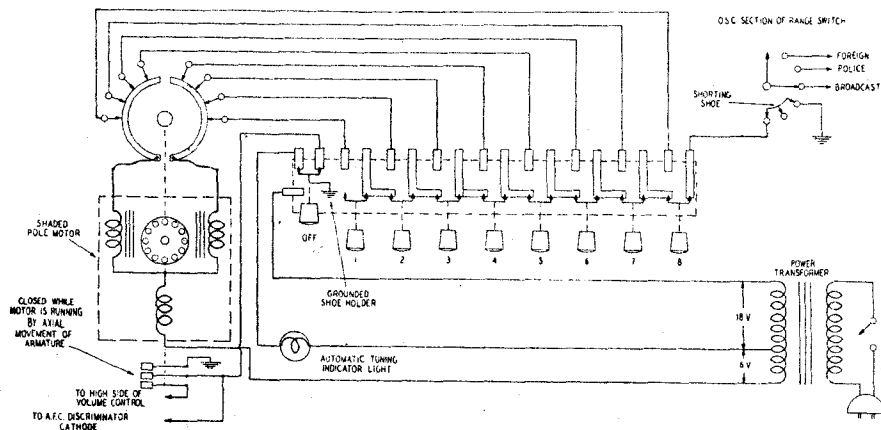

Fig. 32—Schematic Diagram of Typical Motor-Tuned System



AUTOMATIC TUNING

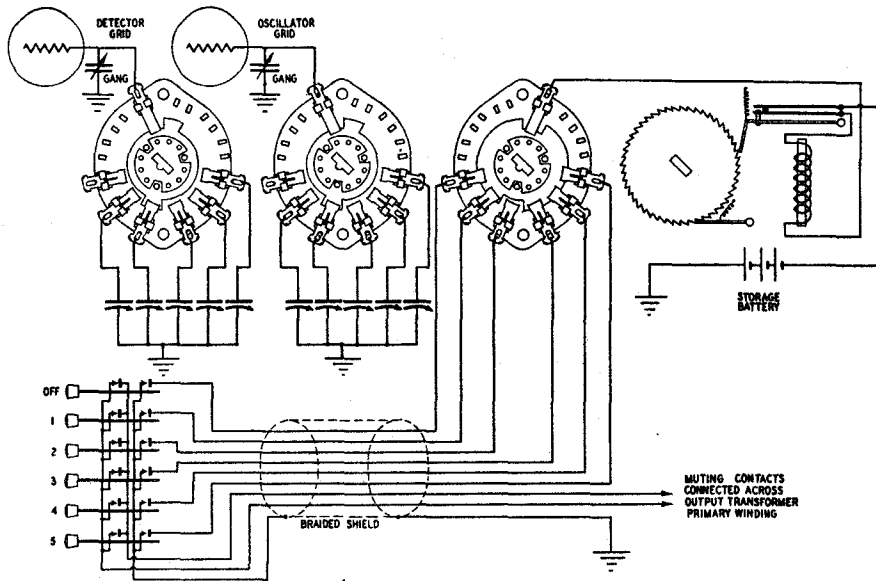

FIG. 47—Admiral "Touch-O-Matic" Motor Car Conversion Unit—Circuit Diagram

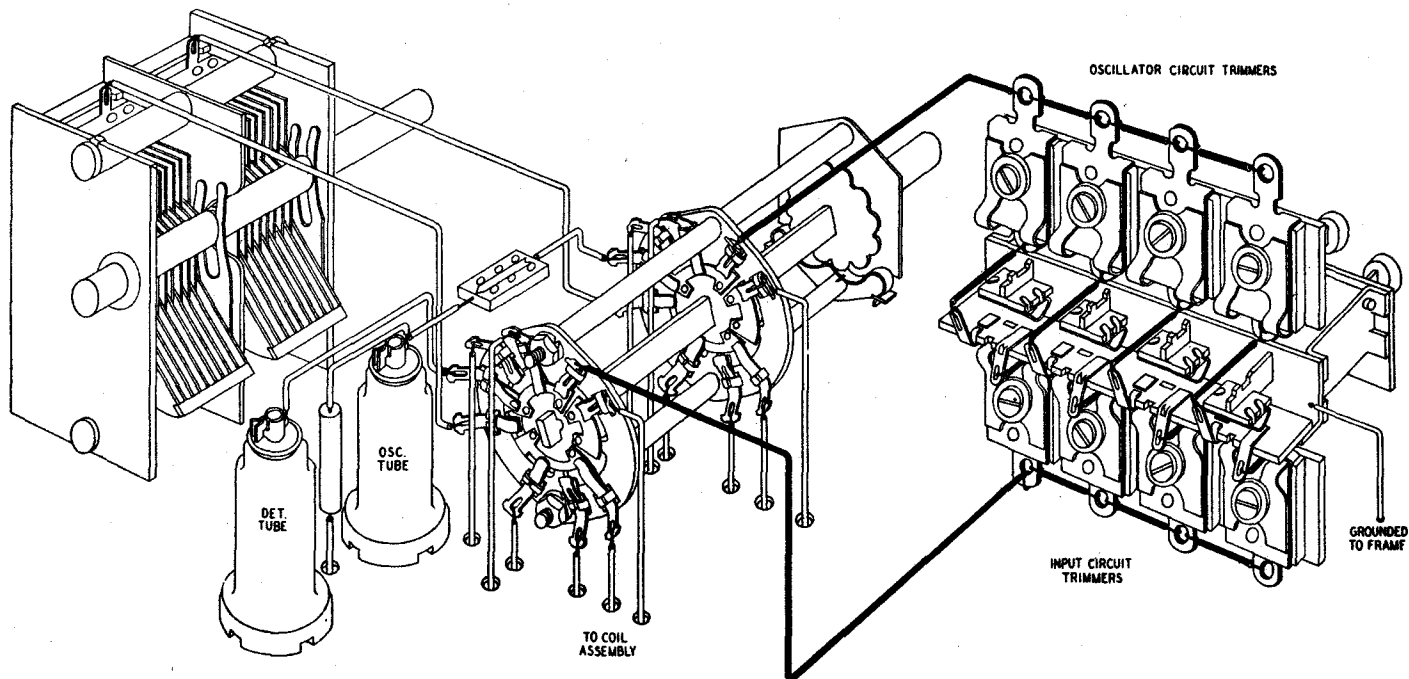

FIG. 21—Typical Condenser Substitution Tuning System

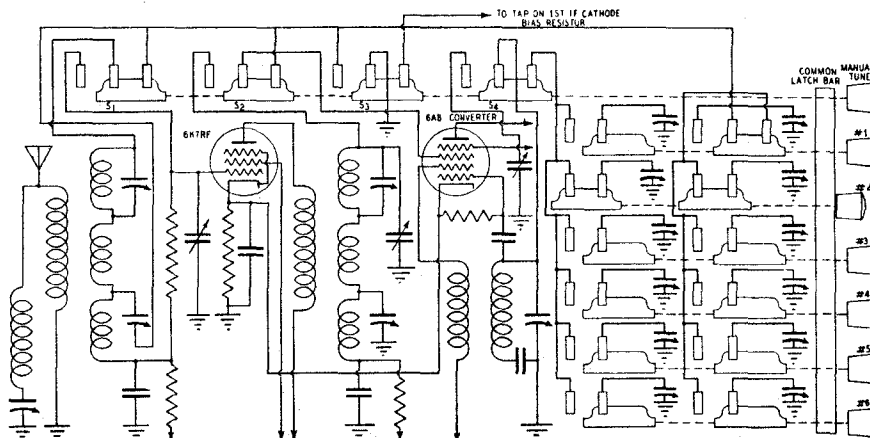

FIG. 73—General Electric "Touch-Tuning"—Circuit Diagram

AUTOMATIC TUNING

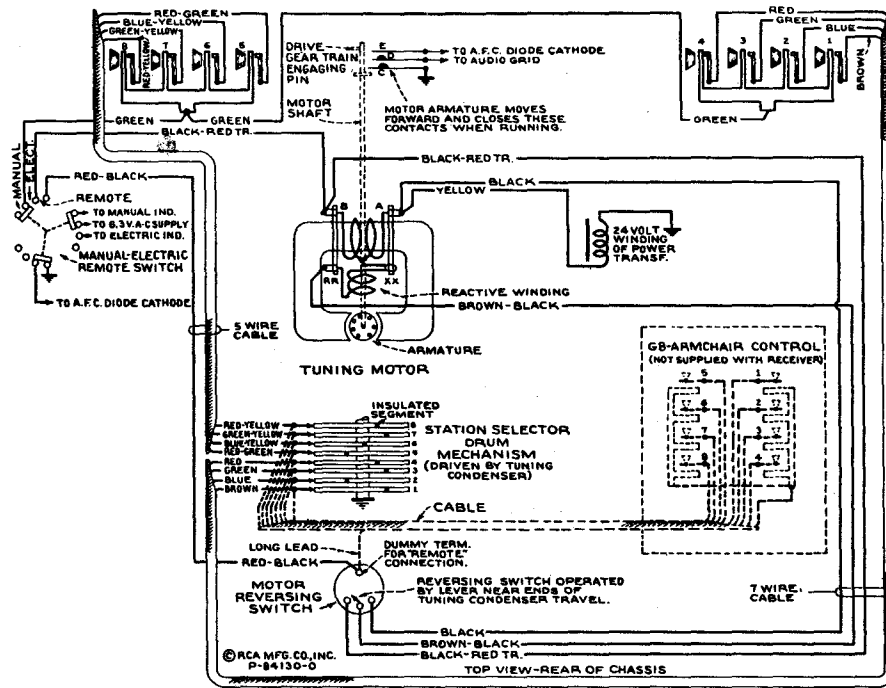

FIG. 61—R.C.A. Motor-Tuning System—Wiring Diagram

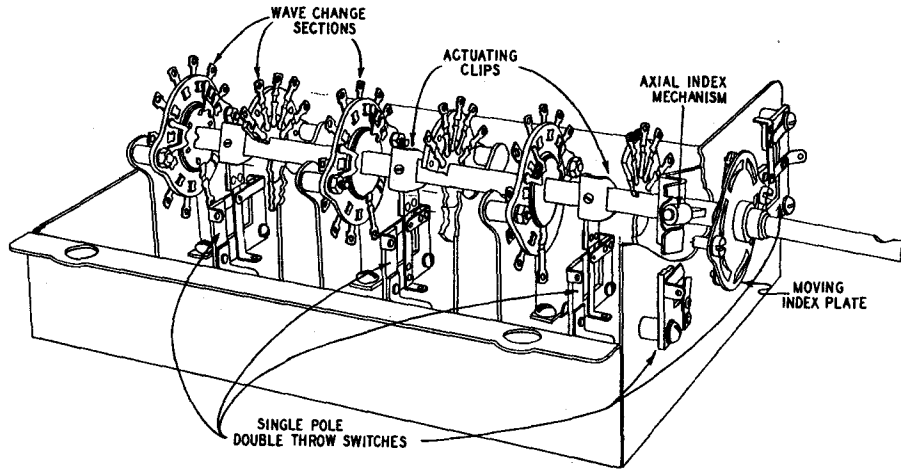

FIG. 62—Sparton "Selectronne"—Transfer Switch Assembly

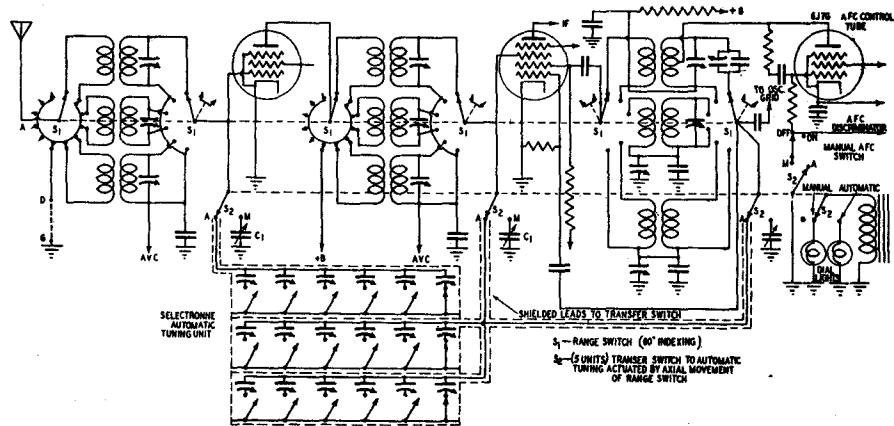

FIG. 63—Sparton "Selectronne"—Schematic Wiring Diagram

AUTOMATIC TUNING

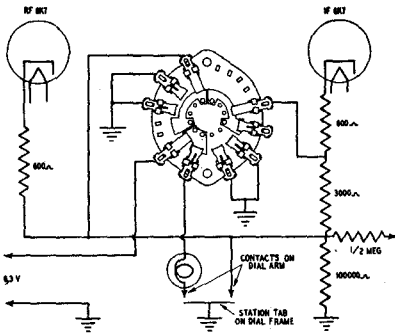

FIG. 67—Erla-Sentinel Muting and AFC Release Circuit Diagram

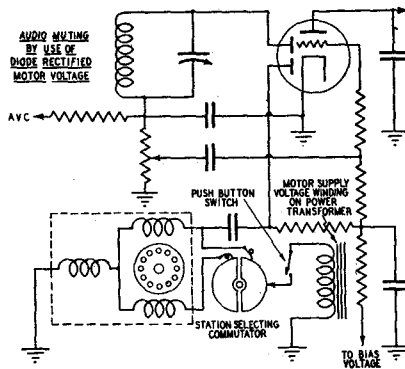

FIG. 79—Detrola Audio Silencing Unit—Circuit Diagram

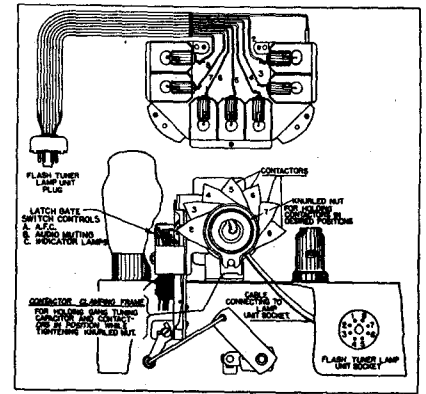

FIG. 15—Stromberg-Carlson "Flash-Tuning" System

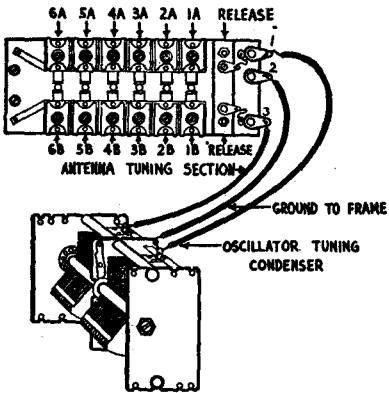

FIG. 54b—Pacific "Selectromatic" Unit—Wiring Diagram

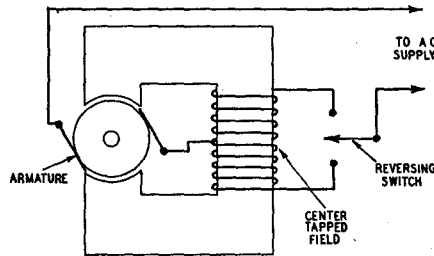

FIG. 42—Delco Motor Wiring Diagram

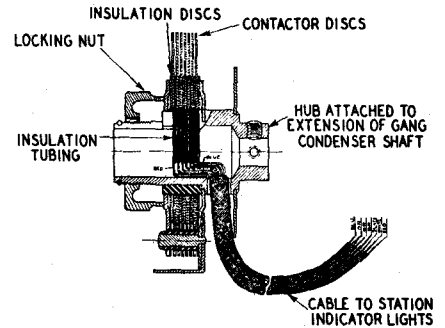

FIG. 15a—Stromberg-Carlson "Flash-Tuning" System

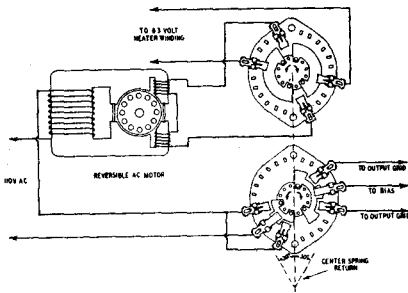

FIG. 81—Zenith Electric Automatic Tuning Wiring Diagram

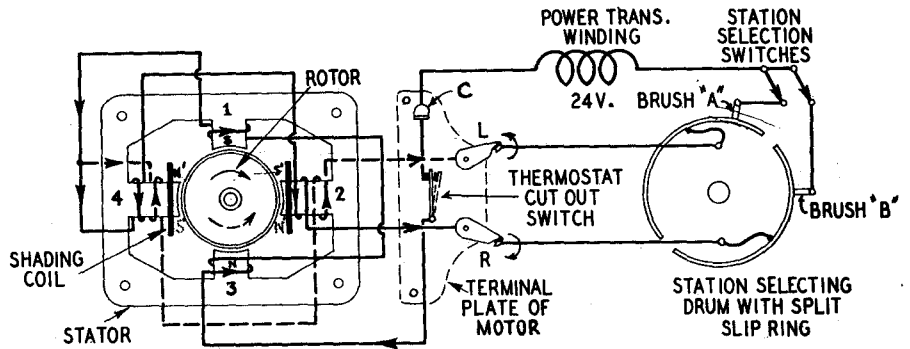

FIG. 38—Shaded Pole Induction Motor (Utah)—Wiring Diagram

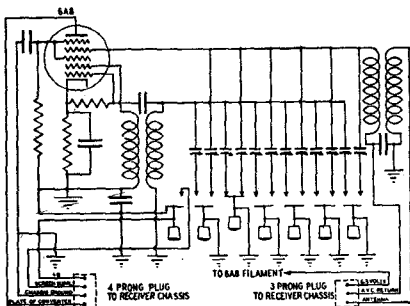

FIG. 74—Howard Automatic Tuning Circuit Diagram

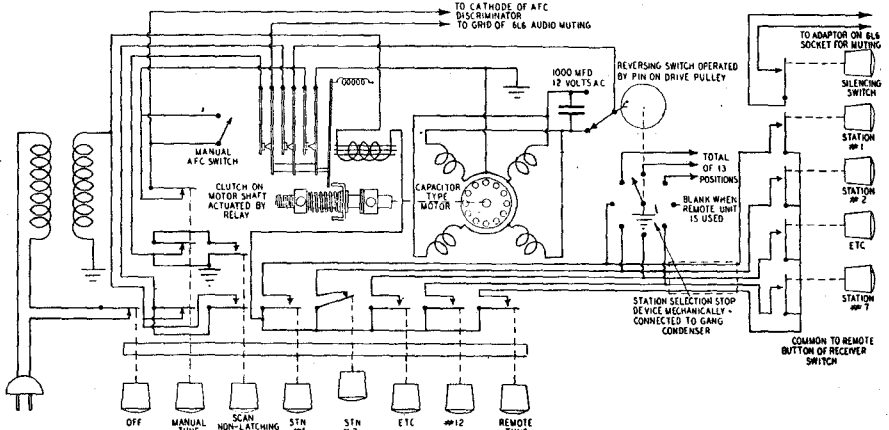

FIG. 78—General Electric Motor-Driven "Touch-Tuning"—Circuit Diagram

PHONO-RADIO SERVICE DATA

Crystal Pickup Installation

A large portion of present day phono-radio combinations (either built as a single unit or radio receivers converted by the use of record playing apparatus) employ crystal pickups. Since the pickup medium is actually the heart of the reproduction system, the first logical step is to become familiar with the characteristics, operation, and care of these units. The following discussion illustrates these points.

If you are called upon to select and install a crystal pickup for record reproduction you have available a considerable choice of styles, types and prices. The final quality of reproduction, however, depends not only on the pickup itself but also on the method of installation. The response of the very finest crystal pickup can be ruined by failure to observe a few basic, simple installation precautions. Actually, proper installation is a simple matter, and by following the suggestions in this article, you should obtain the really fine reproduction for which quality crystal pickups are noted.

Electrically the crystal is the equivalent of a condenser with a capacity of about 1,500 mmfd. The impedance of the device, therefore, is quite high (100,000 ohms at 1,000 cycles and 1 meg at 100 cycles) and

the lower the frequency, the higher the impedance. Instead of a power generator, the crystal pickup may be thought of as a voltage generator which requires a very high-impedance load so that the greater part of the generator voltage, at all frequencies of interest, will appear across the load.

Terminal Impedance

Since the impedance of the pickup is highest at low frequencies, it is evident that the choice of load resistance will directly govern the low frequency response. This effect of terminal impedance on low frequency response holds regardless of any other considerations. It is inherent in the use of the crystal with its capacitive internal impedance. Crystal microphones, of course, display the same effect.

Fig. 1 shows how the terminal voltage is affected by load resistance alone for a crystal of 1,500-mmfd. capacity. A resistance of 5 meg introduces practically no frequency discrimination while lower values reduce the low-frequency response as shown.

Fig. 2 illustrates the effect of load re-

sistance on the response curve of a representative high-quality pickup. Experience has shown that for home reproduction on sets with good speakers, most listeners prefer the elevated bass response obtained with terminations of 0.5 meg or more, and therefore the service man should make certain that the point of connection to receiver or amplifier presents a sufficiently high resistance to the crystal pickup. On the other hand, if the speaker is very small, elevated bass response in the pickup is likely to result in bad distortion due to excessive speaker stiffness and poor radiating ability at low frequencies. In such cases, the practical solution is to reduce the bass response of the pickup until the overall performance is suitable. Try 0.5, 0.25 and 0.1 meg terminations until the best results are attained.

Since the crystal is a capacitive generator, the effect of shunt capacity is merely to reduce the voltage output of the pickup uniformly at all frequencies. No frequency discrimination is introduced by capacity only. Actually, however, the use of a resistance potentiometer volume control, in the presence of various circuit capacities, may introduce some high frequency loss. This, however, also occurs with sources other than crystal pickups. The effect can be minimized by methods which will be discussed.

Many modern receivers have input terminals which will accommodate a crystal pickup. The arrangement is frequently as shown in Fig. 3 where the receiver volume control is a potentiometer in the first a-f grid circuit. The phono-radio switch simply shifts this potentiometer from the phono input terminals to the detector output and vice versa. The receiver volume control also controls the volume on phonograph. The potentiometer should have a resistance of 0.5 to 1.0 meg as explained previously for proper bass response. Sometimes tone compensating circuits are tapped into the potentiometer. They will not ordinarily affect the phono reproduction adversely, but if the frequency response appears to vary considerably as the volume control setting is varied, it is advisable to test the effect of disconnecting the tone compensating networks from the potentiometer. If they prove to be the cause of the trouble, they should be switched out during phonograph operation. If the receiver employs the volume control method shown in Fig. 3 but has no provision for phono

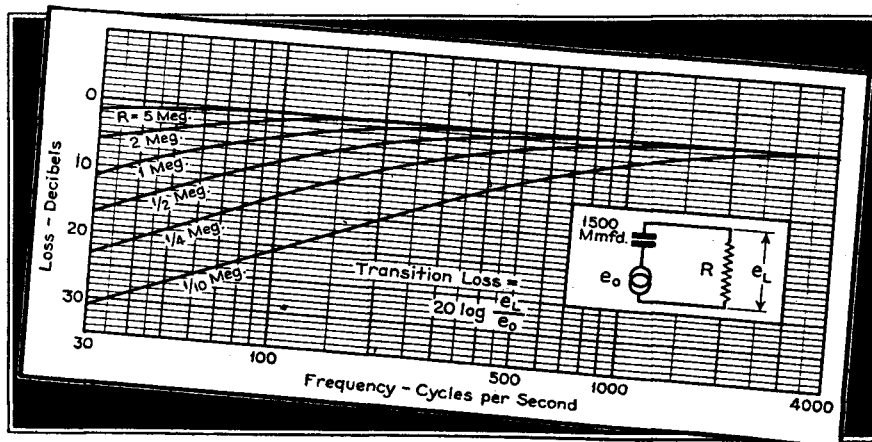

FIG. 1. Since the impedance of the crystal pickup is highest at the low frequencies, the choice of load resistance will directly govern the low frequency response.

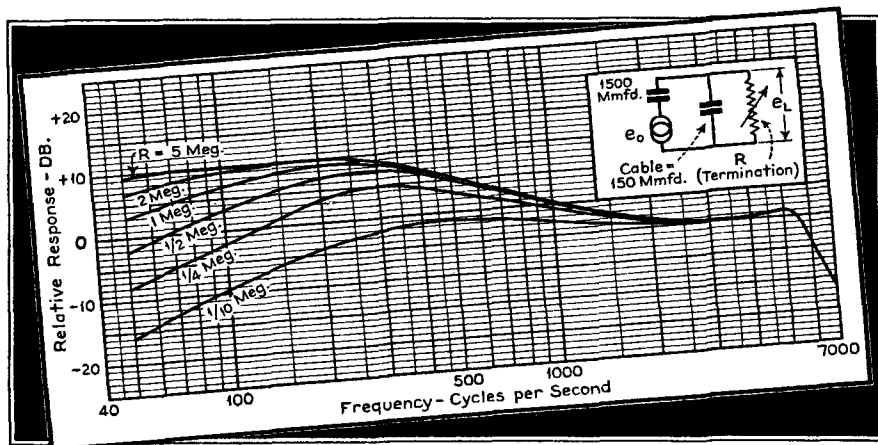

FIG. 2. Experience has shown that most listeners prefer the elevated bass response obtained with terminations of 0.5 meg or more across the pickup.

input, a single-pole double throw switch can be mounted on the chassis and wired as shown. The switch should be located near the potentiometer so that leads will be short and hum pickup possibilities minimized. It is advisable to shield the lead from the phono post to the switch. The switch should make on the phono position before breaking the radio circuit to avoid a thump due to momentary removal of grid bias.

Occasionally the audio system will have such high gain that the pickup will overload the first stage at full volume and necessitate working at such a low setting of the potentiometer that volume adjustments are critical and quality of reproduction may be poor. The remedy is a shunt condenser of 0.001 mfd or larger across the pickup at the input terminals. Increase the condenser capacity until there is no overloading apparent on listening test with the receiver volume control wide open. Pay particular attention to the bass reproduction during the listening test, for the maximum peak levels occur at

the lower frequencies. Increase the size of the shunt condenser until the bass is clean.

It is always good practice to attain normal volume with the audio control of the receiver almost wide open. At medium and low volume settings, the input capacity of the tube plus stray circuit capacities form an L network in conjunction with the resistance in the upper section of the potentiometer with a resulting loss of the higher frequencies. This effect is largely avoided by operating at near-maximum settings.

When a volume control is provided on a simple crystal record player which is located some distance from the receiver, there will almost always be a loss of highs due to the effect of the connecting lead capacity in conjunction with the potentiometer resistance whenever the volume control is turned down below maximum. There is less loss of highs with a relatively low resistance potentiometer (of the order of 0.25 meg) but this may be offset by poor bass response, especially if the record player volume control and the receiver volume control are in parallel and combine to present a still lower terminal resistance to the pickup. When the feature of volume control at the record player is not absolutely essential, the reproduction will usually be improved considerably by disconnecting the record player control entirely, depending on the control at the receiver. Of course these remarks do not apply to record players of the wireless type or to those which incorporate an audio amplifier tube following the pickup; in these cases the tube associated with the pickup may effectively isolate the pickup volume control from the connecting line and subsequent equipment.

Many receivers of early vintage have no provision for phonograph pickup connections; others have phono connections which are only suitable for magnetic pickups. The alert service man can build up his profits by adding crystal record players to such receivers and by modernizing yesterday's phonograph combinations with improved pickups. Circuit changes to accommodate the crystal pickup are not difficult if a few fun-

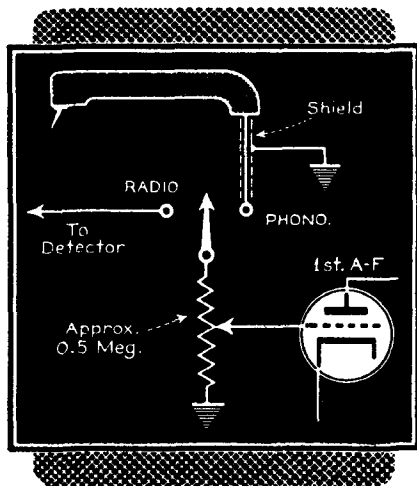

FIG. 3. If the receiver employs the volume control method shown, a single-pole double-throw switch can be wired for phono operation.

damentals are kept in mind. In the first place, transformers are not required. They will not provide the proper terminal connections for high-quality crystal pickup performance. Connect the crystal pickup in the grid circuit of an audio stage across a resistance of 0.5 meg or more (which may be the radio volume control) and make certain that no low-impedance circuits are across the pickup.

A common receiver layout includes a power detector feeding the output stage. Radio volume control is probably effected in a preceding r-f circuit. The best solution is to switch the detector tube grid to a 0.5 meg pickup volume control mounted on the chassis (or motorboard if a combination) at the same time switching the bias to the proper value for Class A audio amplification instead of detection. Fig. 4 shows one possible arrangement.

As before, the switch blade connected to the grid should make in the phono position before breaking the radio circuit to avoid switching thump. The shunt resistor R_2 must have the proper value to make the parallel combination of resistors afford correct amplifier bias. Measure the applied plate voltage and then consult your tube manual for the correct bias voltage and plate current for amplifier operation.

Divide the required bias voltage by plate current to find the resistance which the parallel combination of R_1 and R_2 must provide. After installing the correct resistor R_2 , recheck bias voltage and plate voltage.

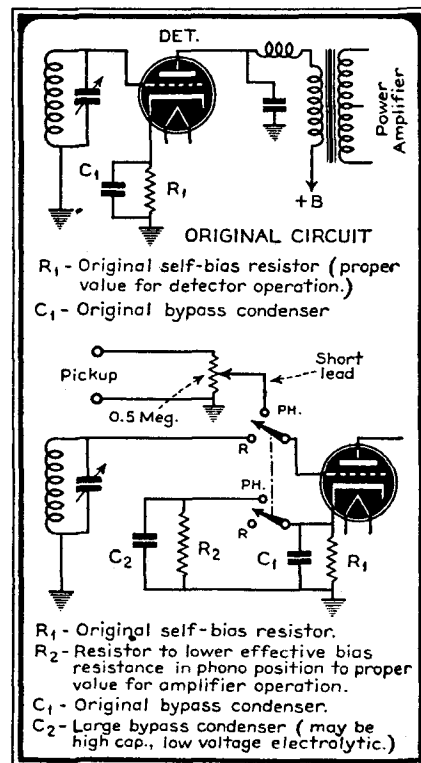

FIG. 4. A common receiver layout includes a power detector feeding the output stage. The best solution is indicated.

Scratch Noise

It has been a common notion that sharply-tuned rejector circuits would eliminate needle scratch or surface noise in phonograph reproduction. The reasoning seems to have been that the disturbing noise was localized in a narrow band around 2500 or 3000 cycles and that the removal of the audio components in substantially this band alone, would considerably lessen the reproduced surface noise with minimum effect on the general quality of reproduction.

Without going into detail regarding special cases that are of little practical interest, it appears that there are no appreciable benefits in narrow band-elimination from the noise reduction standpoint. Surface noise components are of random character and are distributed throughout the entire audio

range. Effective noise reduction goes hand-in-hand with reduction in quality of reproduction. Special needles (such as halftone, cactus, bamboo, etc.), provide some scratch reduction because they cut-off earlier at the high frequency end, with of course a corresponding elimination of what may have been recorded in the lost frequency interval. Adjustment of the ordinary tone control of the receiver or amplifier, with its adjustable, tapering high frequency loss, will probably completely satisfy most listeners.

Additional Hints

Crystal pickups, crystal cutting heads, and crystal microphones will not withstand temperatures above 125°F. for long periods of time. Make sure that adequate cabinet ventilation is provided. Deflect heat from

power and rectifier tubes if necessary with a sheet of asbestos board or other heat insulating material. Such a baffle can be made more efficient by cementing a piece of tin foil to it on the side opposite the pickup unit. Check-up with a thermometer placed at the pickup position. Long experience has proved that the temperature limitation is easily satisfied if it is recognized and given attention.

Should it be necessary to replace the crystal cartridge or cordage, apply minimum heat when unsoldering and resoldering connections at the cartridge terminals. Cool the lug with a cotton swab dipped in alcohol immediately after removing the soldering iron. Heavy-handed sweating-in of soldered joints at the cartridge terminals is practically certain to ruin the crystal. Quick soldering with minimum heat, immediately cooling the joint, is absolutely safe.

Wireless Record Players

Keeping in mind the information obtained from the preceding discussion of crystal pickups we can go a step farther and see how these units are employed in commercial wireless players.

The popularity of wireless record players is undoubtedly due to a number of factors. In the first place, the mystery feature, i.e., the fact that they play through the radio without direct connection, is intriguing. In addition, the record player may be placed at any convenient location, the location being limited only by the distance from the receiver and the convenience of an AC outlet. Further, these wireless players are

relatively inexpensive and simple to operate. When properly designed they are capable of good quality.

The principle of operation of these units is quite simple. As pointed out previously, these record players are nothing more than a low-power broadcast transmitter. Referring to the typical circuit, such as Fig. 33, it will be seen that the unit contains two tubes, one operating as an oscillator-modulator and the other as a rectifier. The oscillator-modulator, generally a 6A7 or similar tube, is modulated with audio by means of the crystal pickup and the phonograph record being played. The oscillator is tunable over a small range in the broadcast band, this tuning being accomplished by means of a trimmer.

Microphone connections are provided in some of the units as an additional feature. Crystal pickups are used in all cases. The turntable speed is, of course, 78 rpm and all units are designed to use either 10 or 12 inch records. In most cases self-starting induction motors are used to drive the turntable, although in some instances a manual-starting synchronous motor is employed. As a result, operation is from a 110-volt, 60-cycle power supply. Detailed information as to trade names, tubes used, turntables, pickups, etc., is given in the chart which accompanies this article.

Various record players and their circuit diagrams are shown in Figs. 33 through 44.

In referring to the schematic drawings a number of rather unusual circuits will be

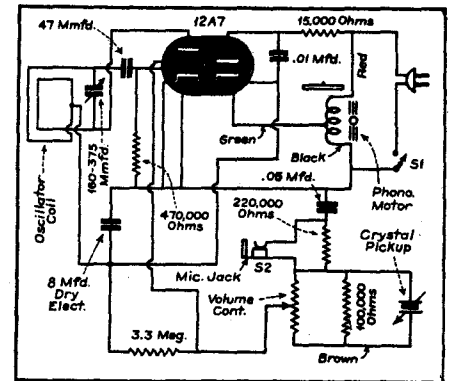

FIG. 34. G.E. (GM11).

noticed. One unit, for example, uses a 12A7 tube as a combined rectifier and oscillator. (See Fig. 34.) Another unique feature of this same unit is the method of obtaining heater voltage. Instead of employing the more conventional method of obtaining heater volt-

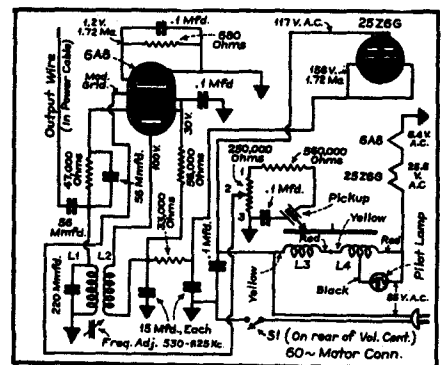

FIG. 35. RCA (VA20, 21).

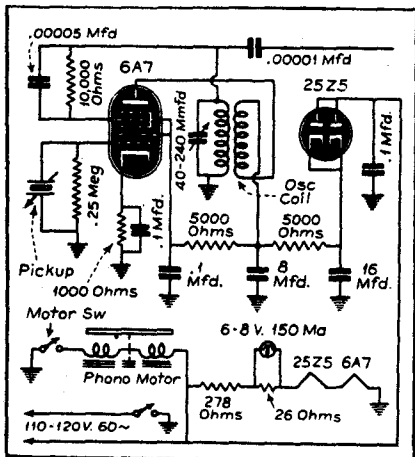

FIG. 33. WILCOX-GAY (A56, A57, A60).

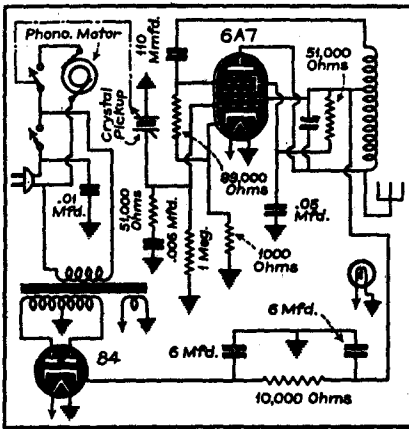

FIG. 36. PHILCO (RP1).

age from the supply line through a ballast resistor, it is tapped off the motor winding. In this connection, it is interesting to note that another unit employs a similar method for obtaining voltage for its pilot lamp (Fig. 35).

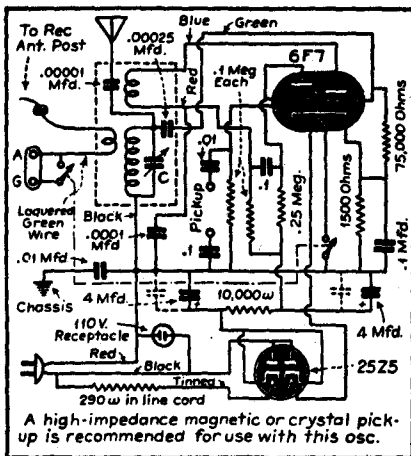

FIG. 37. MEISSNER.

In Fig. 36 is shown a unique method for automatically starting and stopping the turntable by means of the tone arm. When

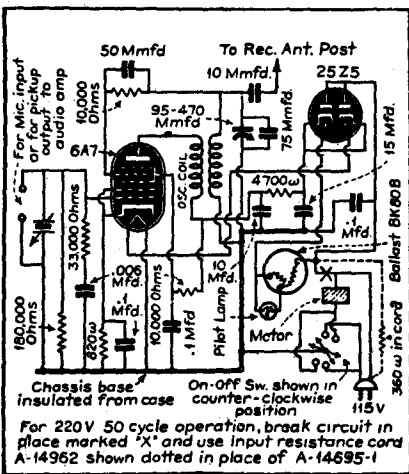

FIG. 38. SPARTON (219P, 219PD).

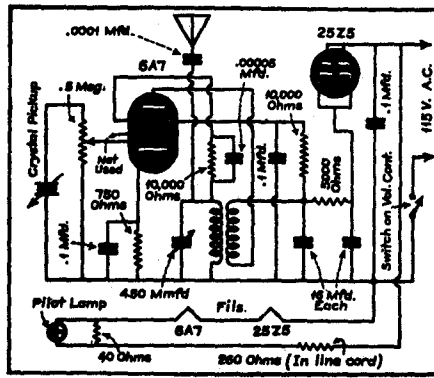

FIG. 39. SONORA.

the pickup is placed on the record, it automatically closes the motor switch and starts the turntable. Similarly, when the tone arm is removed from the record, the motor switch is automatically opened.

Also of interest is the phonograph oscillator shown in Fig. 37. This type of unit is designed for operation through a direct connection to the receiver antenna circuit and will not ordinarily supply sufficient radiated signal to provide satisfactory wireless operation, even if the coil shield is removed. There is no reason, however, why the same components and exactly the same circuit would not provide wireless operation if a simple addition were made.

A radiator connected to the oscillator coil (indicated as an antenna in the circuit of Fig. 37) will provide satisfactory results, especially if this radiator is included in the power line cord. Four to six feet of wire should provide ample radiation. Some difficulty may be experienced from broadcast interference with the signals from the record player. In general the wireless units use a radiation frequency which is more free from such interference.

Particular attention is called to the DeWald Model 411, the schematic of which is shown in Fig. 44.

It is a 2-tube wireless record player that permits the owner to play recordings through a remote radio receiver or directly through an a-f amplifier and a small speaker incorporated in the playback unit. The device employs two new multipurpose 0.3 amp

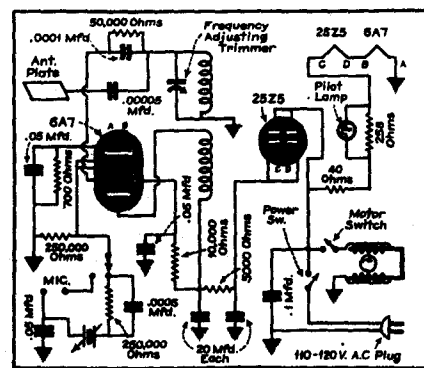

FIG. 40. ADMIRAL (AW11).

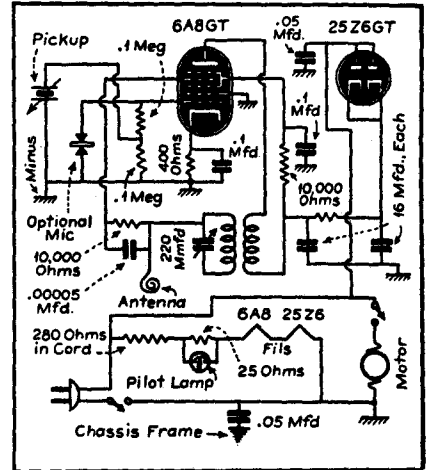

FIG. 41. ESPEY (922)

tubes, the 12B8GT r-f pentode-triode and the 32L7GT beam power amplifier-rectifier.

The high-mu triode section of the 12B8GT amplifier tube serves as an audio amplifier in both modes of operation. With the switch

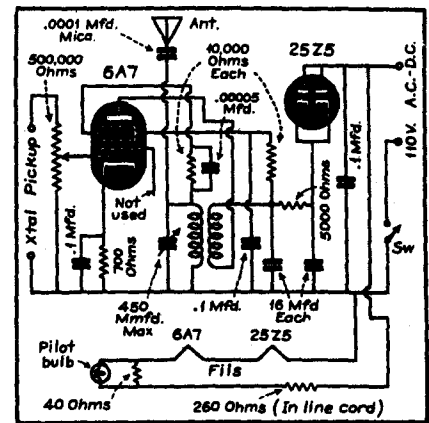

FIG. 42. KNIGHT.

in the r-f playback position, the a-f amplifier is necessary to provide a high percentage of modulation. In wireless playbacks where the pickup operates directly into the r-f oscillator the percentage of modulation is

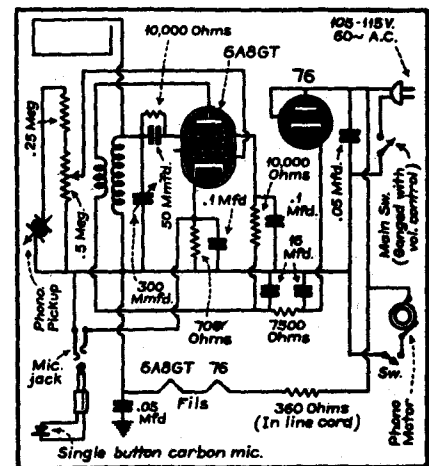

FIG. 43. LAFAYETTE.

THE MYE TECHNICAL MANUAL

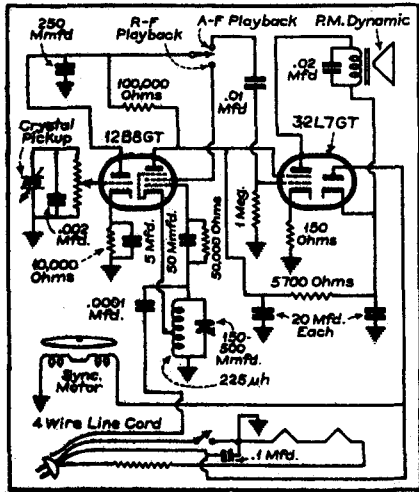

FIG. 44. DEWALD 411.

often too low. This makes it necessary for the listener to turn the receiver gain up higher in order to obtain normal room volume even though a strong carrier is being received from the oscillator. Excessive carrier hum results.

In addition, low percentage modulation requires more radiation to produce a satisfactory signal at the receiver. Also, the interference range of the transmitter varies in-

versely as the depth of modulation. Too high a modulation level, however, would cause frequency modulation and consequent distortion. To prevent this a modulation level control is incorporated as an element of the pickup tone corrector.

With the switch in the audio playback position, a complete record player and amplifier is available with no additional equipment required. This feature is obtained at only a slight additional cost over an ordinary wireless record player, since the power supply, heater resistor and cabinet are required even if this feature were omitted. A power output of 1.4 watts is available to the permanent magnet dynamic speaker.

Two controls are used, one for level with the on-off switch incorporated and the a-f, r-f switch. The carrier frequency is adjustable over a small range around 550 kc. The padder is accessible through a hole in the top of the panel.

A 4-wire line cord is used, 3 wires for the power and filament resistor and the fourth is the antenna. This arrangement with the antenna coupled to the hot end of the oscillator tank through a 0.0001 mfd condenser, allows satisfactory reception as a wireless unit up to about 40 feet. A 0.1 mfd by-pass condenser across the line keeps the r-f energy from the lighting circuit.

A crystal pickup is employed with a tone correcting load circuit. The resistor is the

volume control in the a-f position and the modulation level control in the r-f position. The high-mu triode feeds the beam-power tube in the a-f position or the screen grid of the pentode oscillator section in the r-f position. The plate of the power tube is returned to the input of the filter while the screen is connected to the second filter section to reduce hum. In the a-f position, the oscillator is cut off by opening the screen grid lead.

In setting up a wireless record player, the general procedure is as follows:

The radio receiver should be turned on and tuned to a quiet spot in frequency range covered by the oscillator. The oscillator should then be tuned to the frequency of the receiver. Adjust the volume controls on the receiver and record player to the proper levels. In very noisy locations, it may be necessary to wrap several turns of the oscillator antenna around the antenna lead-in to the receiver. In receivers having push-button tuning, one of the buttons may be set up for the oscillator frequency.

Figures 45 through 73 show schematic diagrams of later types of wireless record players. Most of these units have prototypes already covered in this discussion, and no commentary has been attempted. The general features of these players are listed in the complete table following this record player text. The chart also lists equipment previously discussed.

Manufacturer	Trade Name	Model Number	Frequency Range (In Kc.)	Pilot Light	Tubes		Voltage	Cycles	Meter Type	Turntable			Pickup		Mils. Con- nect- ion	Controls		Dimensions				
					Osc.-Mod.	Rect.				Speed	Diameter (In Inches)	Record Size	Type	Impedance @ 1000 Cycles		Voltage @ 1000 Cycles & 250MA D Load	On-Off	Vol-ume	Hgt.	Widt.	Depth	Wgt. (Lbs.)
Allied Radio Corp.	Knight	—	—	Yes	6A7	25Z5	110-120	60	—	78	—	10" or 12"	Crystal	—	—	No	Combined	—	—	—	—	
Continental Radio & Television	Admiral	AW11 CW13	540 1575	Yes	6A7 128AGT	25Z5 70L7GT	110-120 110-120	60	—	78 78	—	10" or 12" 10" or 12"	Crystal Crystal	—	—	Yes No	Yes No	6 1/2	13	13	14	
Dewald Radio Mfg. Corp.	Dewald	411	550	No	128AGT	32L7GT	110-120	60	Self Start	78	—	10" or 12"	Crystal	—	—	Yes	Combined	—	—	—	—	
Espy Mfg. Co., Inc.	Espy	922	1475-1750	No. 47	6A8GT	25Z6GT	110-120	60	Self Start	78	9	10" or 12"	Crystal	100,000 Ω	1 1/2	Yes	Yes	No	6	14	14	10
Gehrle Mfg. Corp.	Motrolite	11A 21A 22A 23RC, 23RCW	1200-1750 1300-1750 1250-1750 1250-1750	No No No No	—	25A7G 6K6GT 68Z7GT 68C7GT	76 76 61S7GT 61S7GT	110-120 110-120 110-120 110-120	60 60 60 60	— — — —	78 8 8 8	10" or 12" 10" or 12" 10" or 12" 10" or 12"	Magnetic Crystal Crystal Crystal	3,000 Ω @ 400 Cy.	— — — —	No No No No	Yes Yes Yes Yes	No No No No	— — — —	— — — —	— — — —	— — — —
General Electric Co.	GE	GM11 HM31 JM23	1400-1600 1100-1600 1100-1600	No No No	—	12A7 6AB6 6AB8	84 84 84	110-120 110-120 110-120	60 60 60	Self Start Self Start Self Start	78 78 78	10 9 8	10" or 12" 10" or 12" 10" or 12"	Crystal Crystal Crystal	80,000 Ω	1 1/2	Yes Yes Yes	Yes Yes Yes	8 5 6 1/2	15 1/2 10 1/2 14 1/2	13 1/2 14 1/2 11 1/2	10 9 —
Philco Radio & Television Corp.	Philco	RP1 (Codes 121, 122, 123) RP2 41-4P4	530-580 530-580 530-570	Yes Yes Yes	6A7 6A7 6A7	84 84 84	110-120 110-120 110-120	60 60 60	— — —	78 78 78	—	10" or 12" 10" or 12" 10" or 12"	Crystal Crystal Crystal	—	—	No No No	Yes Yes Yes	No No No	— — —	— — —	— — —	— — —
Phiglit Electric Corp.	Phiglit	930	—	No	6A7	76	110-120	60	—	78	—	10" or 12"	Crystal	—	—	No	Yes	No	—	—	—	—
RCA Mfg. Co., Inc.	RCA	YA20, YA21 Osc. 22	530-625 530-625	No. 47	6A7 6SA7	25Z6G 25Z6G	110-120 110-120	60 60	Manual Start	78 78	7	10" or 12" 10" or 12"	Crystal Crystal	100,000 Ω	1 1/2	No No	Combined Combined	3 1/2 7 1/2	12 1/2 4 1/2	8 1/2 2 1/2	7 1/2 —	
Sears Roebuck & Co.	Silvertone	8848 8226 8233	540-700 540-750 530-625	No. 51 No. 1-46 No. 44	35L6GT 6A7 128AGT	35Z6GT 25Z5 35Z6GT	110-120 110-120 110-120	60 60 60	— — Manual Start	78 78 78	8 9 8	10" or 12" 10" or 12" 10" or 12"	Crystal Crystal Crystal	— — 100,000 Ω	— — 1 1/2	No No No	Combined Crystal Combined	— — —	— — —	— — —	— — —	— — —
Sears Radio & Television Corp.	Sears	KYU-85, KYU-97 PFW W17, W19, W24	600 — 600	No Yes No	50L6GT 6A7	35Z6GT 25Z5 32L7	110-120 110-120 110-120	60 60 60	— Self Start —	78 78 78	— — —	10" or 12" 10" or 12" 10" or 12"	Crystal Crystal Crystal	— — —	— — —	No No Yes	Yes No Yes	7 1/2 — —	1 1/2 — —	10 1/2 — —	7 1/2 — —	
Spartan-Wilmington Co.	Spartan	219F, 219FD	1200-1700	Yes	6A7	25Z5	110-120	60	—	78	—	10" or 12"	Crystal	—	—	Yes	Yes	No	—	—	—	—
Stewart-Warner	Stewart-Warner	11-2A1	540-750	No	35L6GT	35Z6GT	110-120	60	—	78	9	10" or 12"	Crystal	—	—	Yes	Combined	—	—	—	—	—
Warwick Mfg. Corp.	Warwick	9-21 9-23	1500-1700 1500-1700	No	6A7 128A7	76 35Z6GT	110-120 110-120	60 60	—	78 78	—	10" or 12" 10" or 12"	Crystal Crystal	—	—	Yes Yes	Yes No	—	—	—	—	—
Whitcomb Radio Service Co.	Lafayette	K219A5	540	No	6A8GT	76	110-120	60	Self Start	78	8	10" or 12"	Crystal	150,000 Ω	3-4"	Yes	Combined	6 1/2	13	10 1/2	13	
Wilson-Gay Corp.	Wilson-Gay	A63 A65 A85 8K2 8P2 9A2	540-750 — — 540-750 — 540-750	Yes Yes No Yes Yes Yes	12AB, 35L6 128A7 12AB 6A7 6A8GT 12AB	25X6 35Z4 35Z4 25Z5 35Z6GT 35Z4	110-120 110-120 110-120 110-120 110-120 110-120	60 60 60 60 60 60	— — — Self Start — —	78 78 78 78 78 78	9 8 10" or 12" 10" or 12" 10" or 12" 10" or 12"	Crystal Crystal Crystal Crystal Crystal Crystal	— — — — — —	— — — — — —	No No No No No No	Combined Combined No No No No	— — — — — —	— — — — — —	— — — — — —	— — — — — —		
Zenith Radio Corp.	Zenith	84432 87000, 87001, 87082, 87003 88500, 88501	— 1540 540-900 1200-1300	Yes No No	6L7G 128A7GT 128A7GT	6X5G 35Z6GT 35Z6GT	110-120 110-120 110-120	60 60 60	— — —	78 78 78	— — —	10" or 12" 10" or 12" 10" or 12"	Crystal Crystal Crystal	— — —	— — —	No No No	Yes Yes Yes	No No No	— — —	— — —	— — —	— — —

*Infinite Impedance Load

Ballast Tube Circuits

It has been popular in receivers of the AC-DC type, and in battery-powered receivers, to use plug-in type ballast resistors. The following information is presented to aid in identifying and checking the various ballast types.

In a large number of instances the type designation stamped on the tube indicates the value and circuit arrangement of the unit. As an example let us select one of the commonly used types such as BK55B.

The first letter "B" indicates that a ballast section for one or more pilot lamps is used.

The second letter, "K" in the above example, indicates that the pilot lamp (or lamps) is one of the 150 milliampere (0.15 ampere) type. The letter "L" at this position would indicate use of the 250 milliampere pilot lamp while the letter "M" would mean that a 200 milliampere lamp is employed.

The number 55 (or any number used in the same location) gives the total voltage drop across the resistance including the pilot

lamp (or lamps) at the current specified during normal operation.

The final letter "B" indicates the circuit arrangement. Reference is made to the popular type base wiring diagrams as shown below, where circuit B illustrates the wiring diagrams for either octal or UX type base.

Particular attention should be used in any types bearing the "E" circuit designation since both circuit "E" and "E₁" have been used under the plain "E" classification.

WIRING DIAGRAMS

PLUG-IN RESISTORS WITH OCTAL OR "UX" BASES

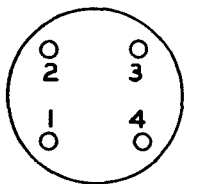
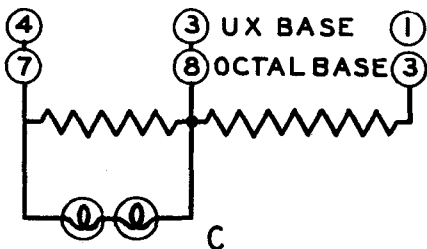
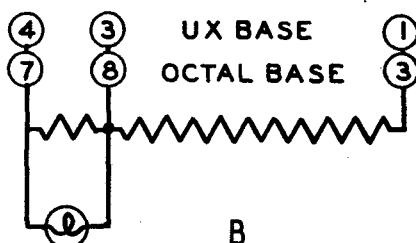
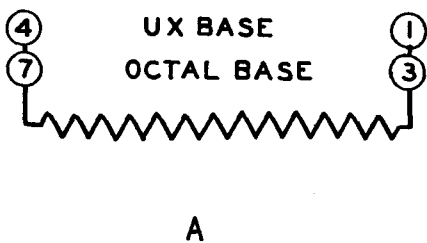

BOTTOM VIEW OF "UX" BASE

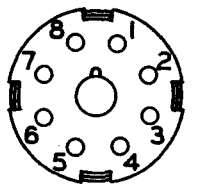
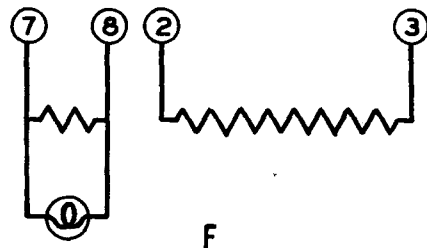
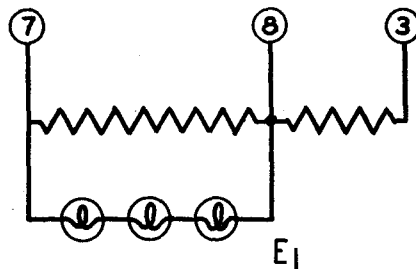
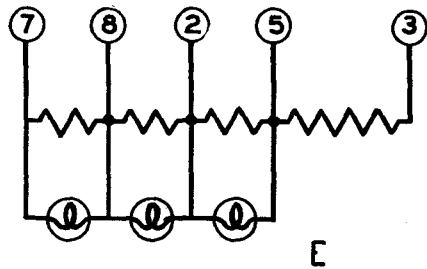
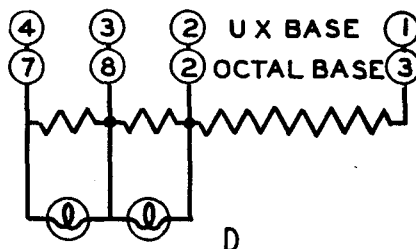

BOTTOM VIEW OF OCTAL BASE

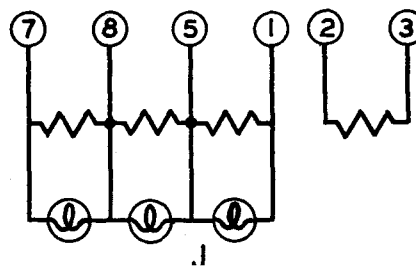
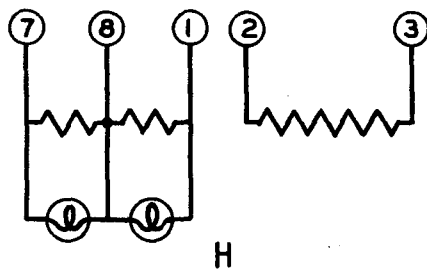
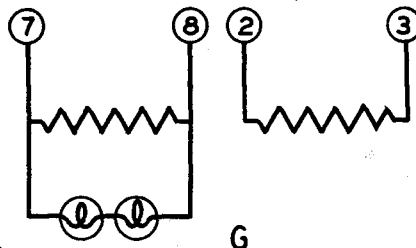

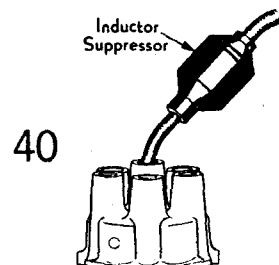
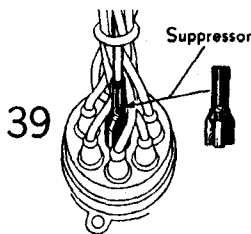
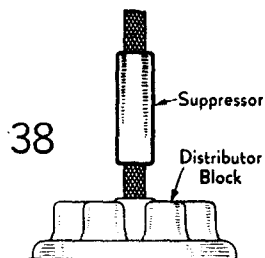
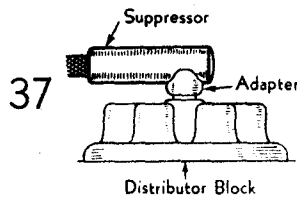
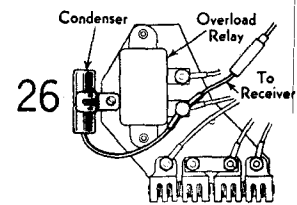
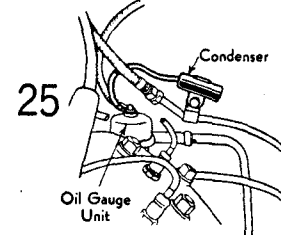
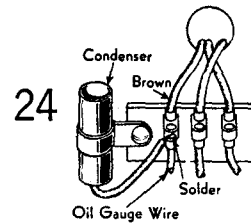
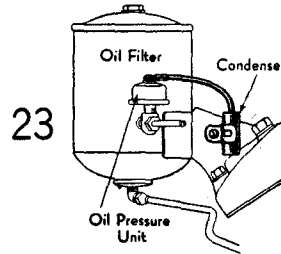
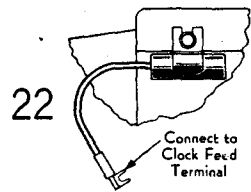
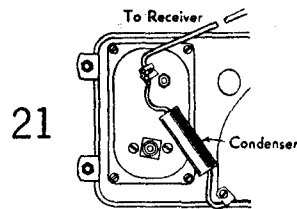
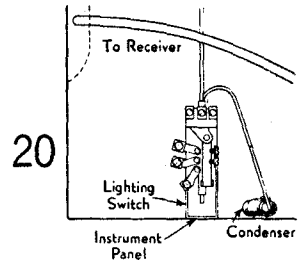
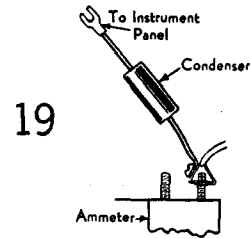
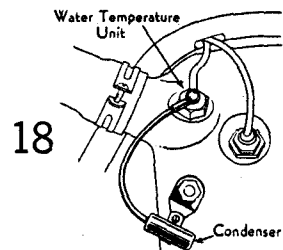
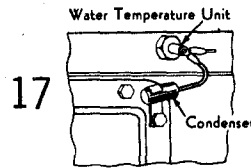
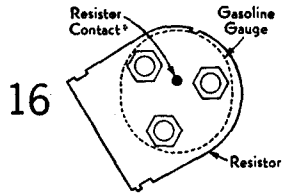
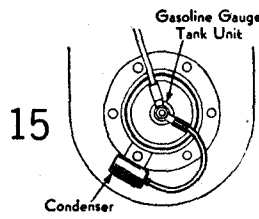
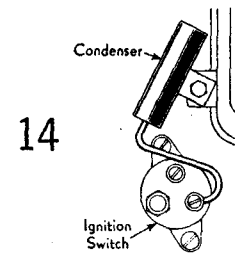
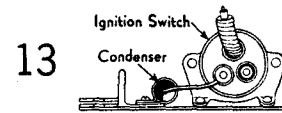
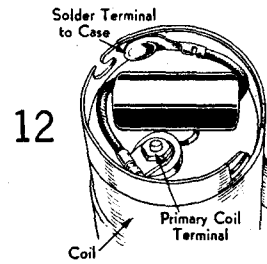
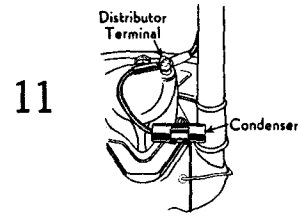
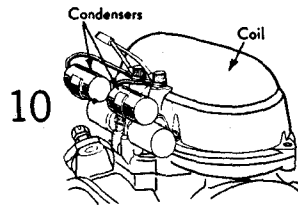
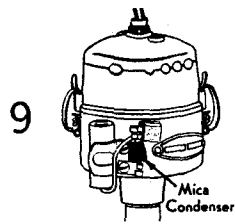
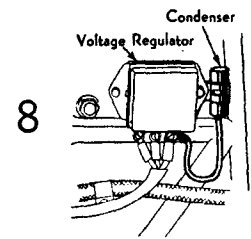
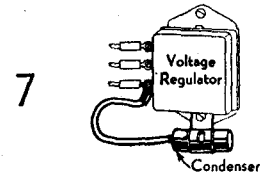
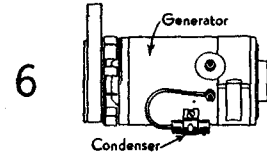
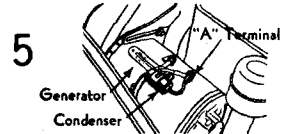
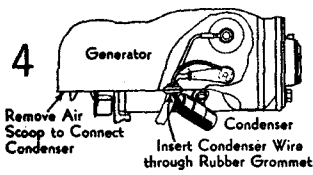
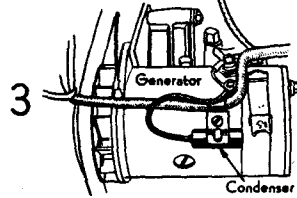
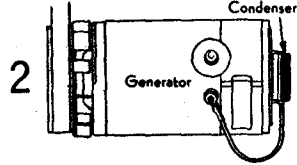
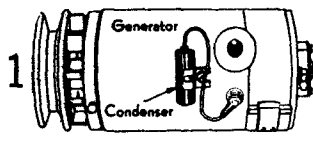

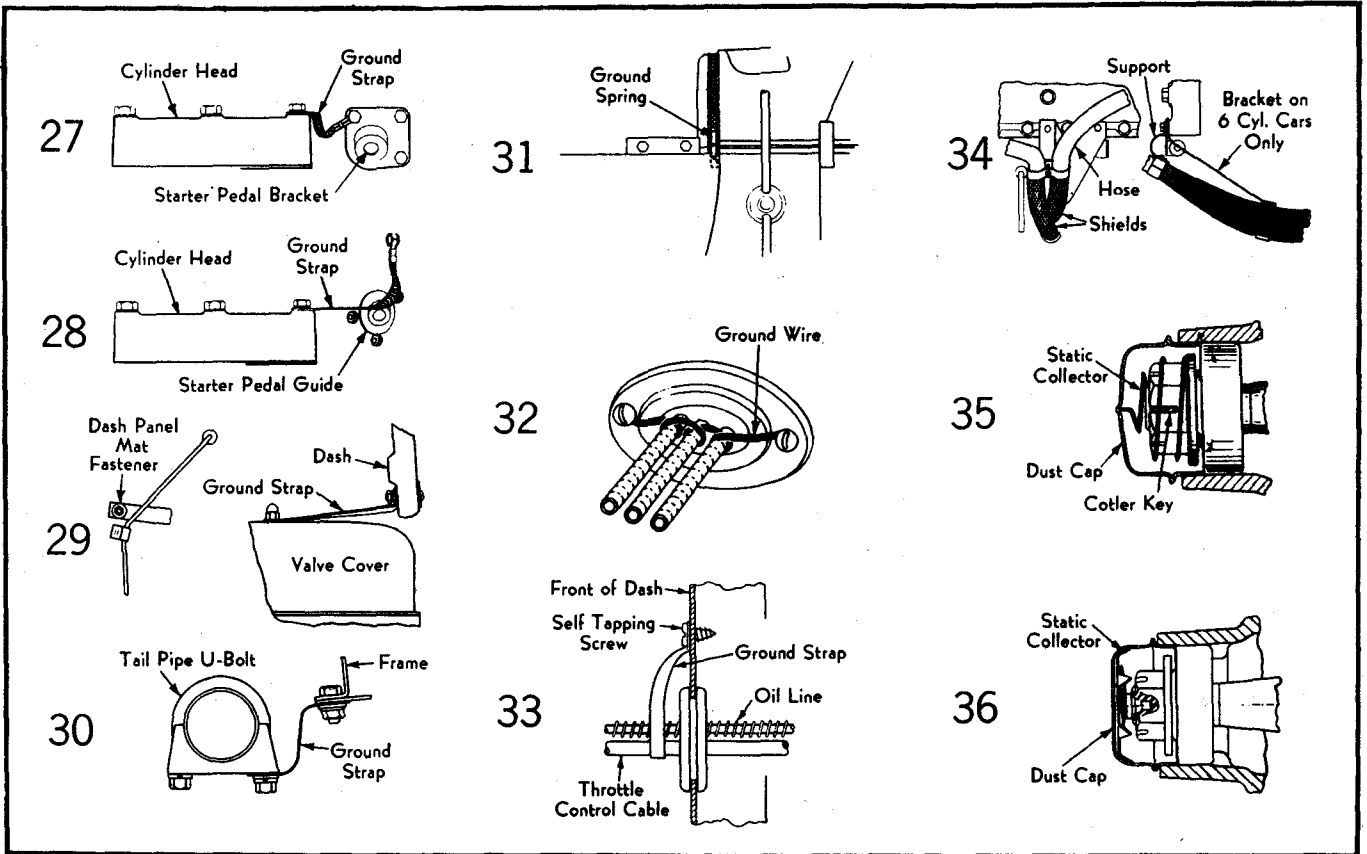

INTERFERENCE ELIMINATION CHART	Battery terminal grounded distributor suppressor	Water temperature gauge	CONDENSERS										GROUNDS						
			Oil pressure gauge	Ignition coil	Generator	Ignition switch	Voltage regulator	Ammeter	Oil-line gauge	Distributor	Clock	Circuit breaker	Front wheels	Cylinder head	Hood	Dash controls	Muffler	Steering column	Hester hose
Buick	N 39		12	6										36					
Cadillac	P 39		12	4										36		33			
Chevrolet	N 37			6	14			21						36	29		30		
Chrysler	P 39			5						16					31	32			
DeSoto	P 39			5						16					31	32			
Dodge	P 39			5						16					31	32			
Ford	P	25				7				11									
Graham	P 40			3	*														
Hudson	P 38	17		2	13					15				*					
LaSalle	P 39		12	4										36		33			
Lincoln-Zephyr	P	18	23			8		15	10		26								
Mercury	P	25				7				11									
Nash	P 38			5											31				
Oldsmobile	N 37			6				19						35					
Packard	P 38			5	*		*				22								
Plymouth	P 39			5						16					31	32			
Pontiac 6	N 37			6				20						36	27				34
Pontiac 8	N 37			6				20						36	28				34
Studebaker Champ	P 38			1						16					32		*		
Studebaker Comm.	P 40			1															
Studebaker Pres.	P 40			1							9								
Willys	N 38	24	6																

Numbers refer to illustrations

Star * indicates unit is used but not illustrated.

AUTO RADIO INSTALLATION

WHEN installing an auto-radio receiver be sure to select an aerial which will give the best results with the set being used, for auto-radio sets, being very sensitive, often are designed to operate with a certain type of aerial. Some sets have separate connections for different types of aerials while on others an adjustment must be made to compensate the set for the aerial being used. It is also easier to install some types of aerials on certain cars and following the manufacturer's recommendations will save time and eliminate difficulties in making an installation.

The recommended list of where the installation of the suppressors, condensers, ground straps and static collectors will normally result in clear reception on each car is shown in the accompanying table. After they have been installed as described the set should be tested to see if they sufficiently eliminate interference.

NON-SYNCHRONOUS TYPE

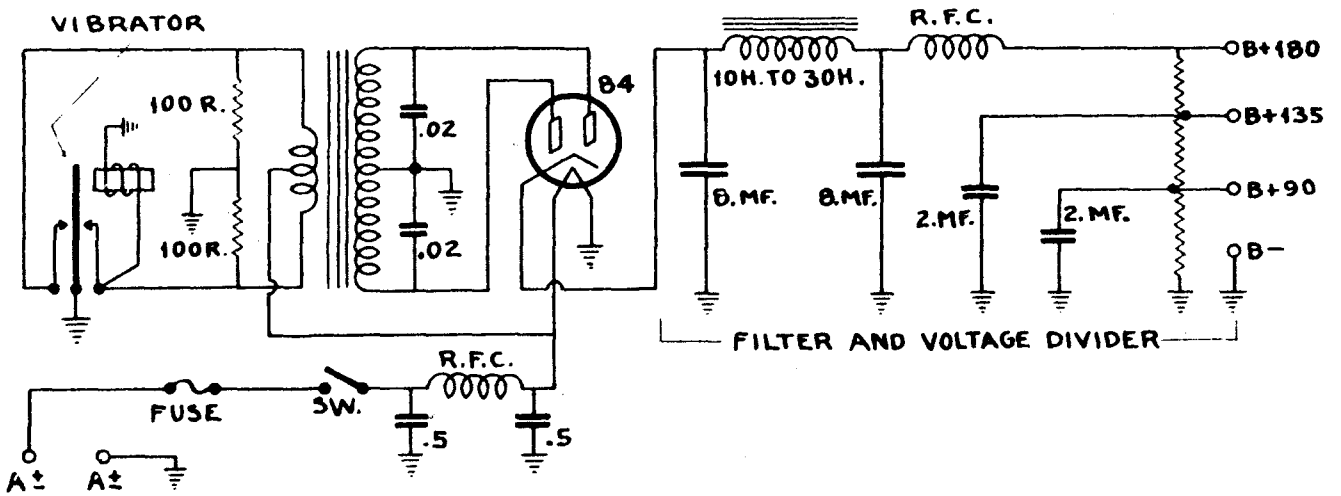

NON-SYNCHRONOUS TYPE

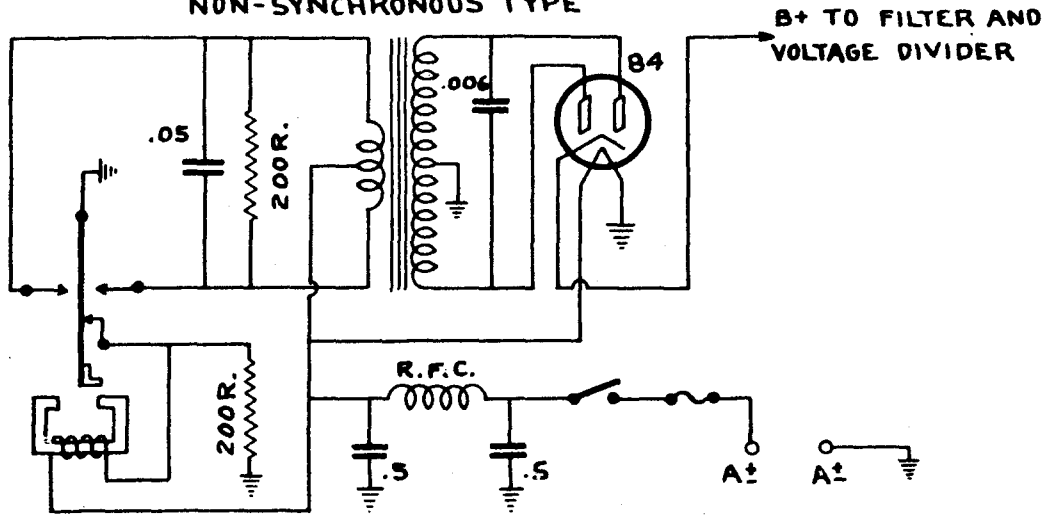

SYNCHRONOUS TYPE

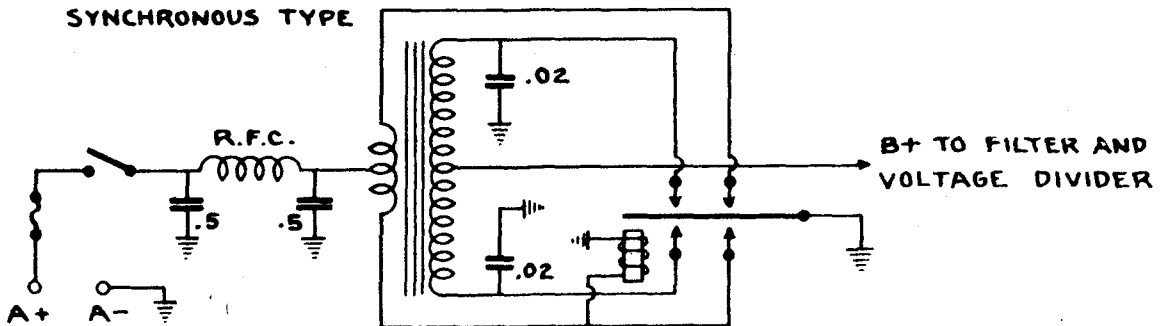

AUTO RADIO VIBRATORS

VIBRATOR TESTERS (DAYRAD)

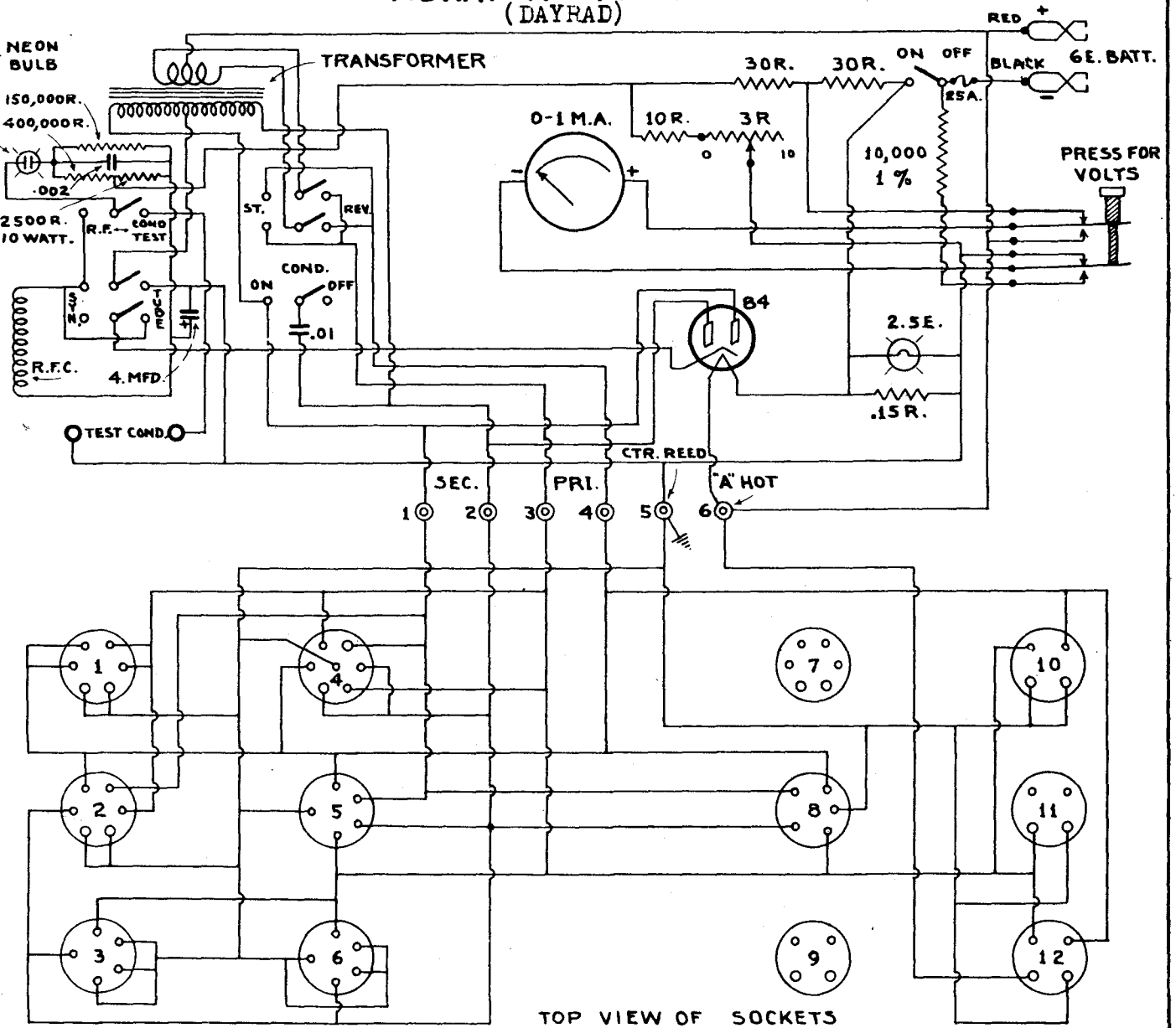

TOP VIEW OF SOCKETS

COYNE VIBRATOR TESTER

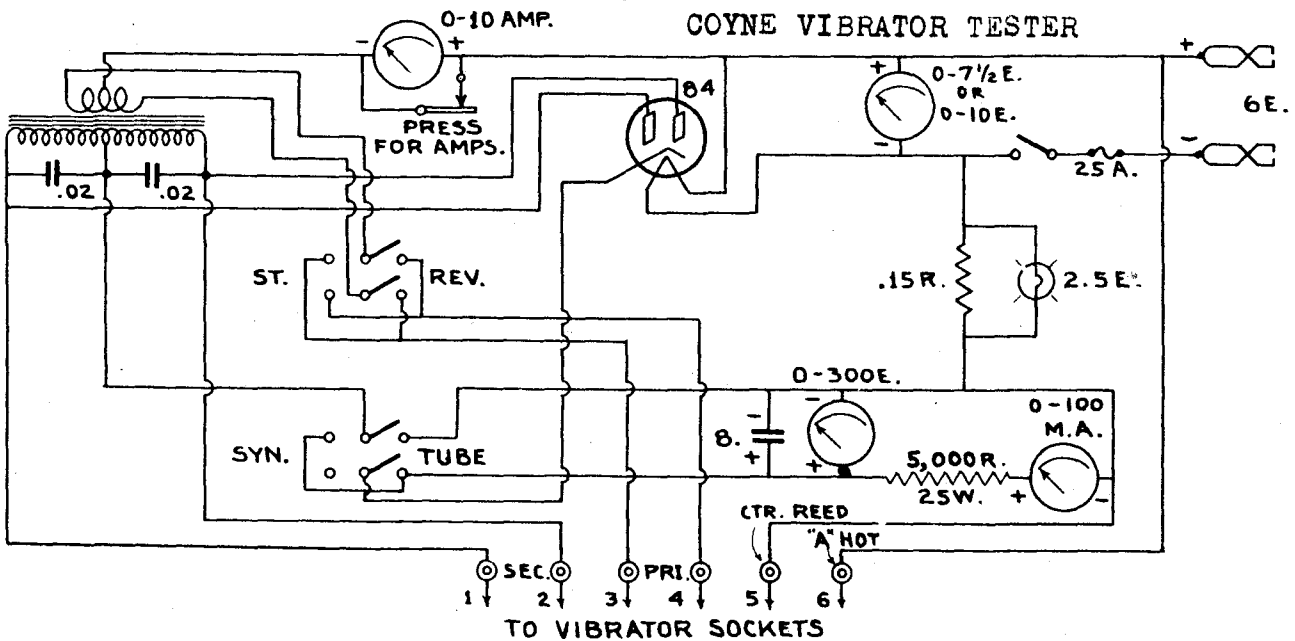

TO VIBRATOR SOCKETS

SOUND.

NATURE OF SOUND

Surrounding the earth and extending outward from it for a distance of about 200 miles is an envelope of air. The weight of this column of air creates a pressure on the earth's surface which, at sea level, is equal to 14.7 lbs. per square inch. The human ear is continually subjected to this pressure but is not aware of it because the pressure on the inside and the outside of the eardrum are the same. When the air pressure varies, the membrane in the ear moves back and forth: Communicated to the brain by nerve currents, this action produces the sensation of sound. Thus it is seen that sound depends upon the variations in air pressure.

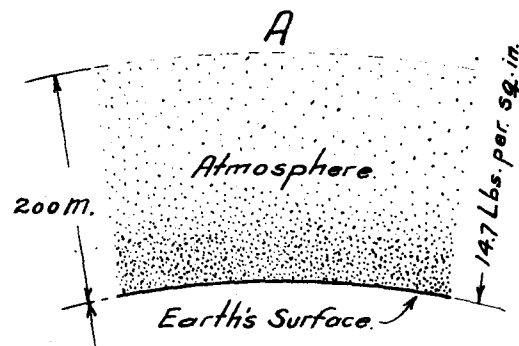

DEFINITION

Sound is a succession of variations in pressure above and below the normal atmospheric pressure of 14.7 lbs. per square inch.

CHARACTERISTICS

Sound vary with regard to one another in three ways: amplitude or loudness; frequency or pitch; and harmonic content or quality.

Sounds having the same amplitude and frequency may vary considerably with respect to quality due to one sound having more or stronger harmonics than the other.

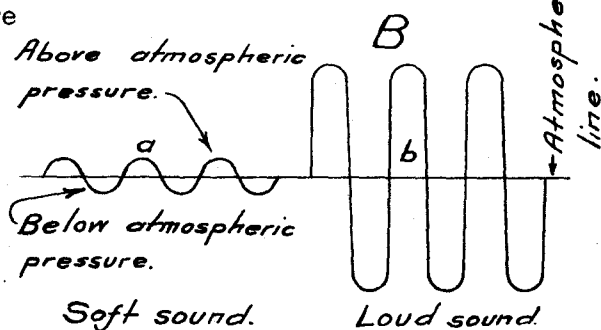

1. Amplitude: Curve a in Fig. B shows a sound of relatively low amplitude, the variations in pressure are relatively small and the sound is low or soft. Curve B shows a sound wave having pressure variation double the amplitude of curve A; this curve portrays a louder sound.

2. Frequency: As the number of cycles per second executed by a vibrating body increases, the pitch of the sound rises. Each octave increase in pitch represents a doubling in the frequency of vibration of the sounding body. Curves in Fig. C show the pressure variations of two sounds having the same amplitude but different frequencies.

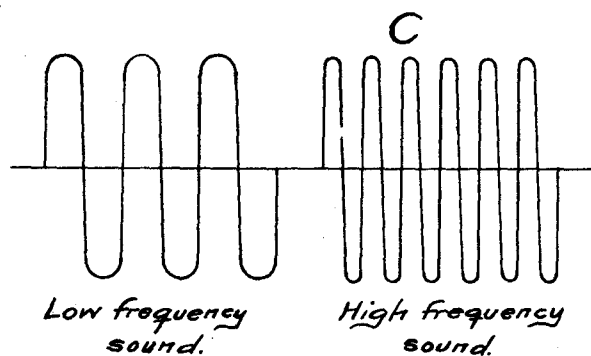

Frequency ranges:

The fundamental frequency of the male voice is about 120 cycles per second.

The fundamental frequency of the female voice is about 240 cycles per second.

The range of frequencies transmitted by the ordinary telephone is 250 to 2500 c.p.s.

The harmonics associated with human speech sounds may run as high as 8000 c.p.s.

Cutting off the frequencies above 8000 c.p.s. eliminates the s, f, th, and z sounds.

Few radio receivers will handle frequencies below 100 or above 4000 cycles per sec.

Frequencies from 16 c.p.s. to 16000 c.p.s. are registered by the human ear.

Because they can be heard, frequencies in this range are called **AUDIO FREQUENCIES**

SOUND.

QUALITY

It is readily possible to distinguish the difference between the note sounded on a piano and the same note played on a violin, yet these sounds may have the same fundamental frequency and the same amplitude. The factor which gives to any particular vibrating body its quality is the harmonic content of the sound produced.

Although it is sometimes assumed that air pressure variations follow a regular curve, such as that shown in Fig. F, this is rarely the case. Actually the motions of a vibrating body are very complex, the unit vibrating in several different modes at the same time. Thus a vibrating string may vibrate as a whole and, at the same time, vibrate in several sections at the same time. The air pressure variations produced by such a vibrating unit will be quite unlike the smooth and regular pressure shown by the curve in F.

All bodies have a certain natural period of vibration; when thrown into vibration by striking or by some other means, the body tends to vibrate at this natural or fundamental frequency; however, this does not mean that other frequencies cannot be produced at the same time. Fig. D shows the air pressure variations produced by a vibrating string that is generating not only its fundamental note, but a double frequency note, or second harmonic, besides. Fig. E shows the complex sound pressure variations that result from a body that produces three different frequencies at the same time. Note that the resultant curve is obtained by adding together the three curves which constitute a first harmonic, second harmonic, and third harmonic. Most sounds are of a similar complex character.

WAVELENGTH

As the tuning fork vibrates, pulses of compression and rarefaction travel away from it at the speed of sound: 1100 ft. per second. The variations in pressure from point to point is shown by the curve. The distance between two pressure conditions that are one cycle apart is called a wavelength. If the frequency of the fork is known, the wavelength of the sound produced by it may be readily obtained by the formula below.

The same formula may be employed to determine the wavelength of a radio wave, the only difference being that instead of 1100 feet per second, the velocity of radio waves is 300,000,000 meters per second, for radio energy travels with the speed of light. When using the formula, it is always necessary to express frequency in cycle per second, and velocity in feet per second for sound, and meters per second for radio energy.

A cycle is a complete series of events that is continuously repeated in the same

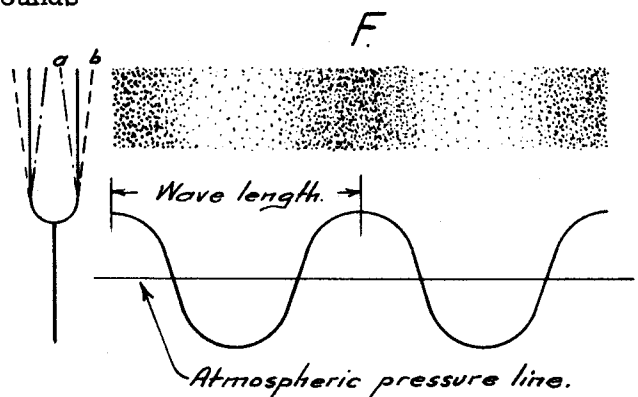
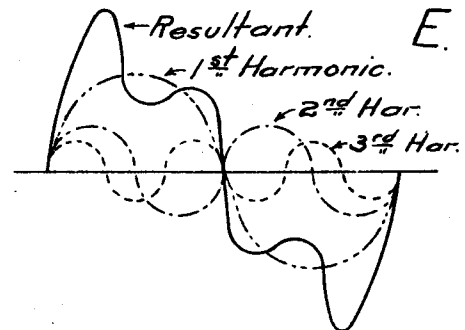
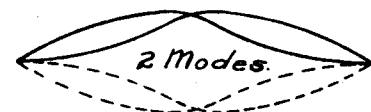
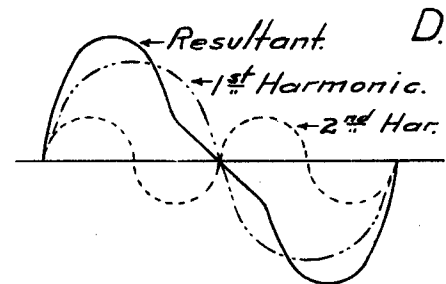
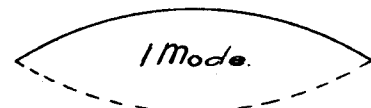

$$\lambda = \frac{v}{f}$$

$\lambda =$ Wave length.
 $v =$ Velocity.
 $f =$ Frequency.

SOUND PRINCIPLES

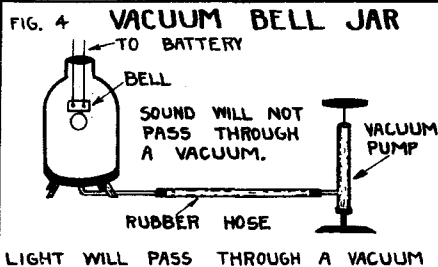
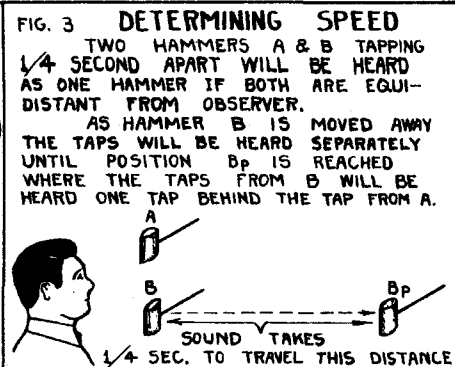
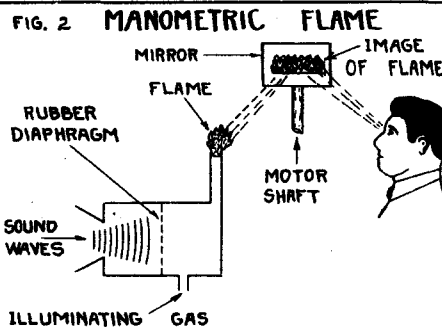
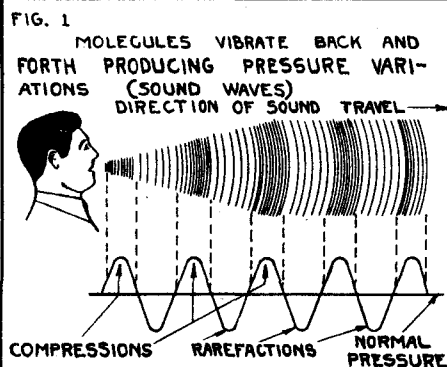

FIG. 5 VELOCITY OF SOUND IN VARIOUS MATERIALS

$V = \sqrt{\frac{E}{d}}$ WHERE V=VELOCITY
E=ELASTICITY
d=DENSITY

MATERIAL	VELOCITY FEET PER SEC.	DENSITY GRAMS/C.C.
AIR	1130	.001205
HYDROGEN	4136	.00009
MERCURY	4615	13.6
WATER	4793	1.0
BRICK	11979	2.0
CORK	1574	.24
IRON	16526	7.9
ELM (WOOD)	3411	.54
GLASS (FLINT)	13120	3.0

FIG. 9 VOLUME LEVEL IN DECIBELS

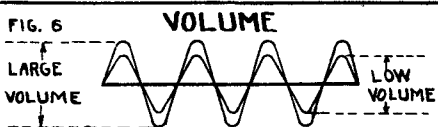
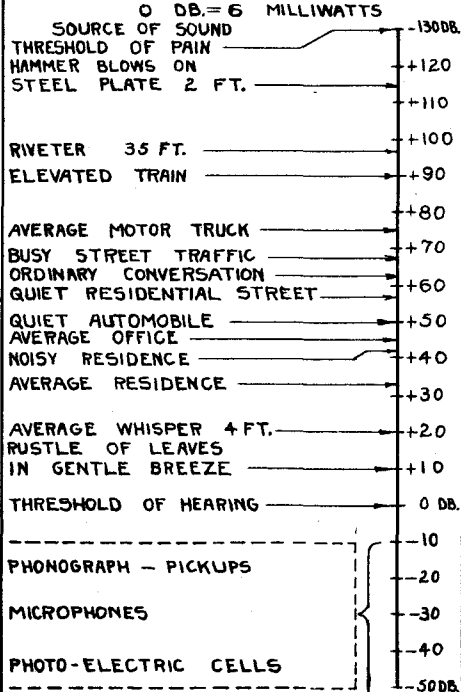

FIG. 8 DECIBEL CONVERSION CHART

CHANGE IN DB. = $10 \times \log_{10} \frac{P}{P_1}$ WHERE P & P₁ ARE IN WATTS.
DECREASE OF 1 DB. = WATTS X 4/5
" " 2 " = WATTS X 2/3
" " 3 " = WATTS X 1/2
" " 10 " = WATTS X 1/10
FOR INCREASE OF GIVEN DB. INVERT FRACTION AND MULTIPLY. TO FIND FRACTION FOR 7 DB. DECREASE - FOLLOW PROCEDURE SHOWN BELOW.
 $7DB. = 2DB. + 2DB. + 3DB. = 2/3 \times 2/3 \times 1/2 = 2/9$

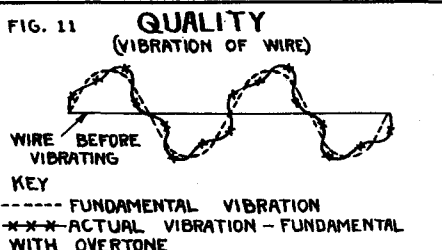
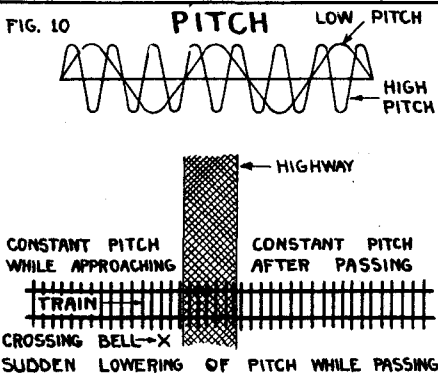
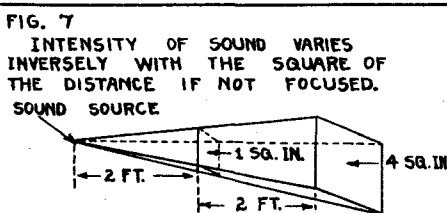
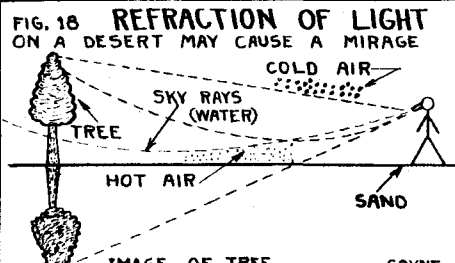
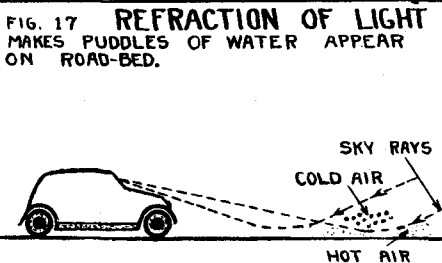
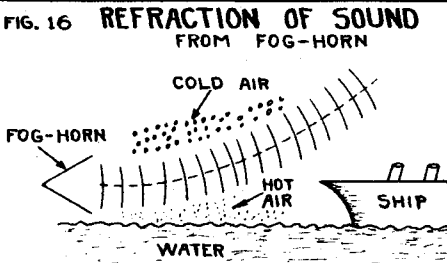
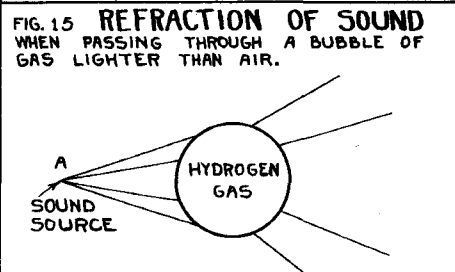
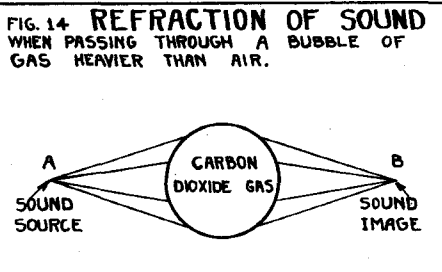
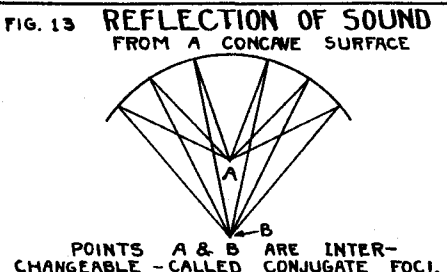
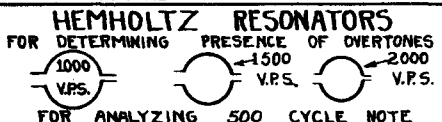
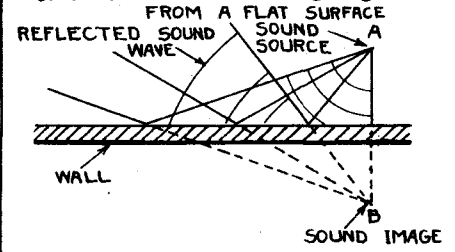
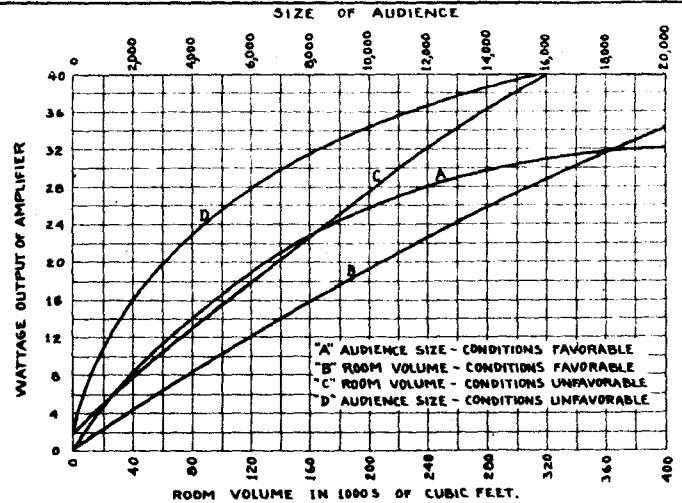
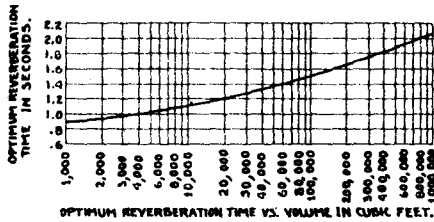

FIG. 12 REFLECTION OF SOUND



SOUND VOLUME CHART



A CAREFUL STUDY OF THE FOLLOWING EXAMPLE WILL FAMILIARIZE YOU WITH THE PROPER USAGE OF THE ABOVE CHART. IT IS DESIRED TO FIND THE MINIMUM WATTAGE REQUIRED FOR UNFAVORABLE CONDITIONS IN A ROOM HAVING A VOLUME OF 100,000 CU.FT. USING CURVE "C" WE FIND WATTAGE NECESSARY FOR THIS ROOM TO BE 23 WATTS. NOW ASSUME THE SIZE OF THE AUDIENCE TO BE 1000 PERSONS. USING CURVE "D" WE FIND 1000 PERSONS REQUIRE 11 WATTS. THE LOWEST PERMISSIBLE POWER IS A COMPROMISE BETWEEN 11 AND 23. THIS IS FOUND BY ADDING 11 AND 23 THEN DIVIDING BY 2. THE ANSWER IS 18.

SOURCE OF SOUND POWER LEVEL IN DECIBELS
 0 = 6 MILLIWATTS

THRESHOLD OF PAIN	+130
HAMMER BLOWS ON STEEL PLATE-ALMOST PAINFUL (2 FT.)	+120
RIVETER (35 FT.)	+100
ELEVATED TRAIN (15-20 FT.)	+90
AVERAGE MOTOR TRUCK (15-50 FT.)	+80
BUSY STREET TRAFFIC (15-75 FT.)	+75
ORDINARY CONVERSATION (3 FT.)	+70
RATHER QUIET RESIDENTIAL STREET (15-300 FT.)	+65
QUIET AUTOMOBILE (15-50 FT.)	+60
AVERAGE OFFICE	+50
NOISY RESIDENCE	+40
AVERAGE RESIDENCE	+30
AVERAGE WHISPER (4 FT.)	+20
RUSTLE OF LEAVES IN GENTLE BREEZE	+10
THRESHOLD OF HEARING	0
CRYSTAL PHONO-PICKUPS	-10
MAGNETIC PHONO-PICKUPS	-20
*SINGLE BUTTON CARBON MICROPHONES	-30
*DOUBLE BUTTON CARBON MICROPHONES	-40
*CRYSTAL MICROPHONE (DIAPHRAGM)	-50
*SOUND CELL CRYSTAL MICROPHONE	-60
*PHOTO-ELECTRIC CELLS	-70
*DYNAMIC MOVING COIL MICROPHONES	-80
*AVERAGE CONDENSER MICROPHONES	-90
*VELOCITY MICROPHONES	-100
*NORMAL CONVERSATION 1 FT. FROM MICROPHONE.	-100

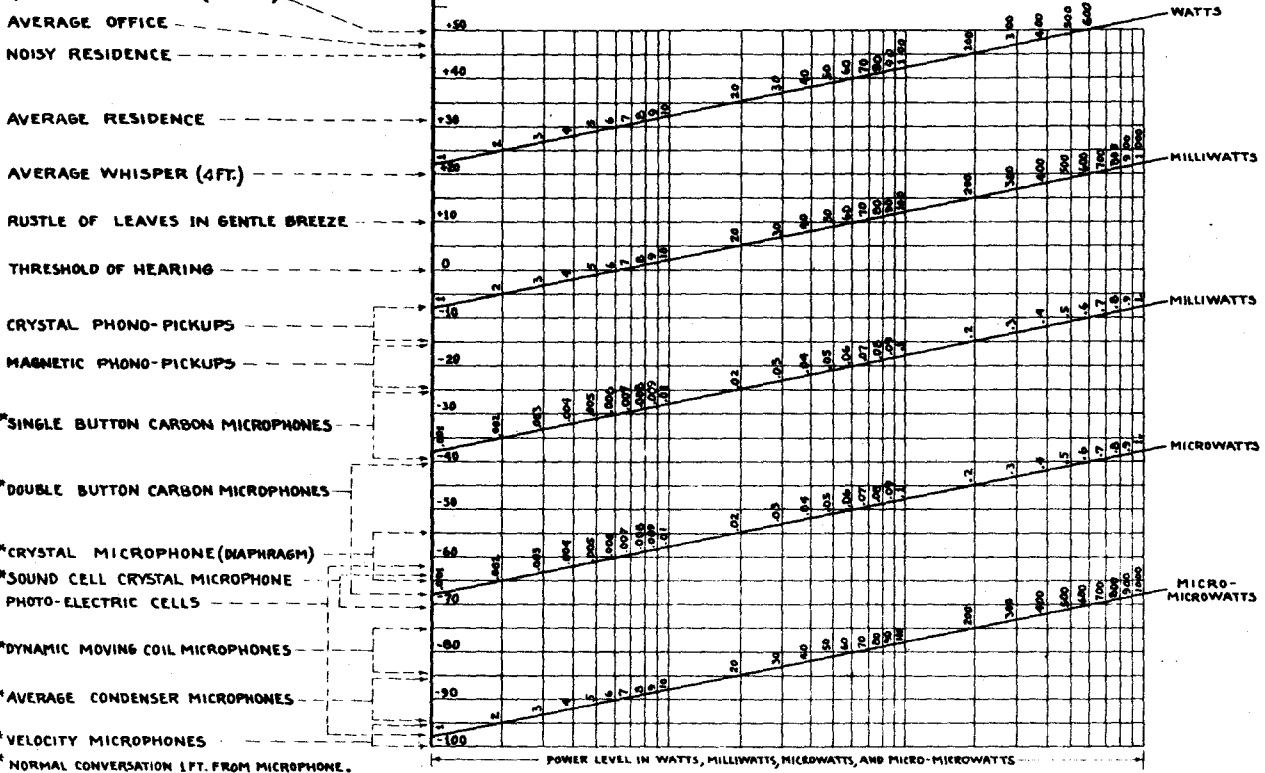

COEFFICIENTS OF ABSORPTION (512 VIBRATIONS PER SECOND).

	UNITS PER SQUARE FOOT.		UNITS PER SQUARE FOOT
ACOUSTI-CELOTEX, TYPE "B", PAINTED OR UNPAINTED	.47	OPEN WINDOW	1.00
ACOUSTI-CELOTEX, TYPE "BB", PAINTED OR UNPAINTED	.70	PLASTER	.025 to .034
BRICK SET IN PORTLAND CEMENT	.025	SABINITE ACOUSTICAL PLASTER	.21
CARPETS	.15 TO .29	SANACOUSTIC TILE, 1" ROCK WOOL FILLER	.74
CONCRETE	.015	WOOD SHEATHING	.061
CORK TILE	.03	WOOD, VARNISHED	.03
CRETONNE CLOTH	.15		
CURTAINS IN HEAVY FOLDS	.50 TO 1.00		
FLAXINUM 1/2"	.34		
GLASS, SINGLE THICKNESS	.027		
HAIRFELT 1/4" (JOHNSMANVILLE)	.31		
HAIRFELT 1" (JOHNSMANVILLE)	.59		
LINOLEUM	.03		
MARBLE	.01		
NASHKOTE, TYPE "A", 3/4" THICK	.27		

INDIVIDUAL OBJECTS	
AUDIENCE, PER PERSON	4.7
COMPLETELY UPHOLSTERED CHAIRS	3.0
PARTIALLY UPHOLSTERED CHAIRS	1.6
PLAIN CHURCH PEWS, PER LINEAR FOOT	.18
PLAIN PLYWOOD AUDITORIUM CHAIRS, EACH	.24
UPHOLSTERED CHURCH PEWS, PER LINEAR FOOT	UP TO 1.6

MICROPHONES

SINGLE BUTTON CARBON MICROPHONE

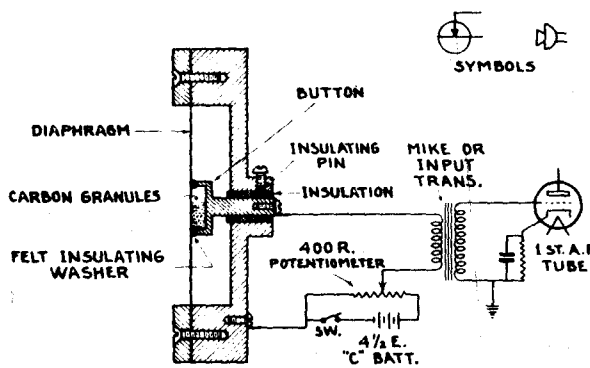

DOUBLE BUTTON CARBON MICROPHONE

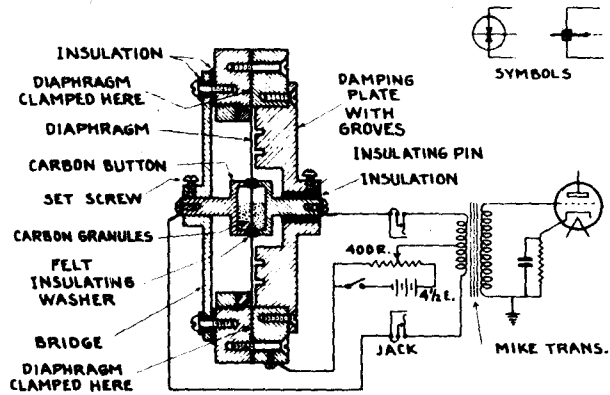

RIBBON MICROPHONE COMBINATION PRESSURE AND VELOCITY OPERATED

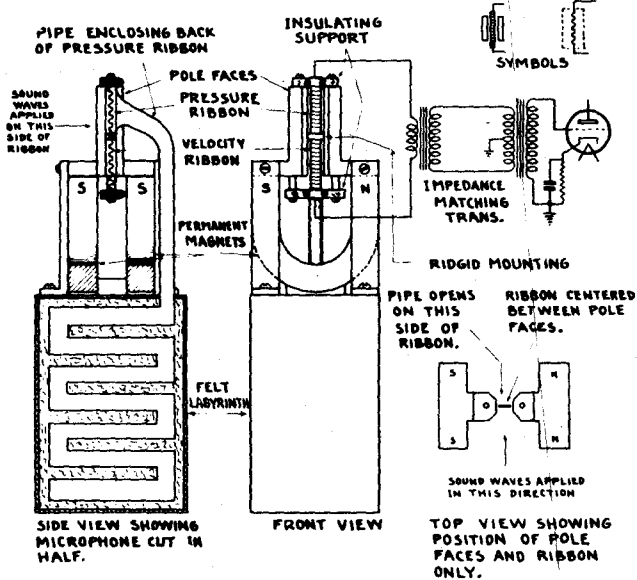

CONDENSER MICROPHONE

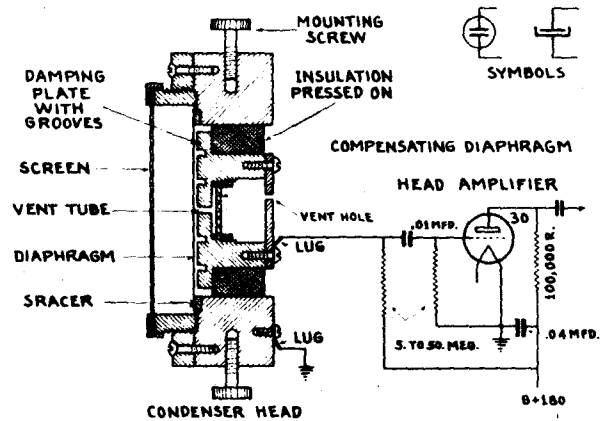

CRYSTAL MICROPHONE - DIAPHRAGM TYPE

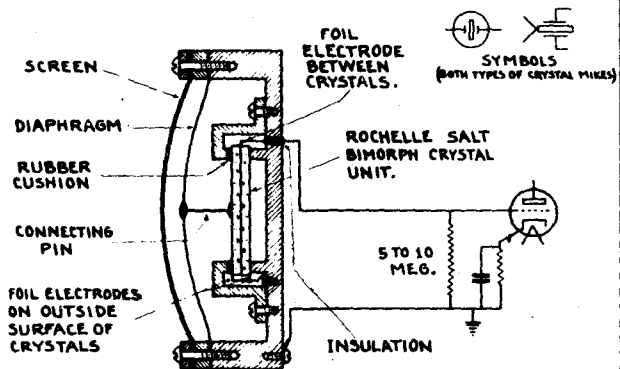

MOVING COIL MICROPHONE

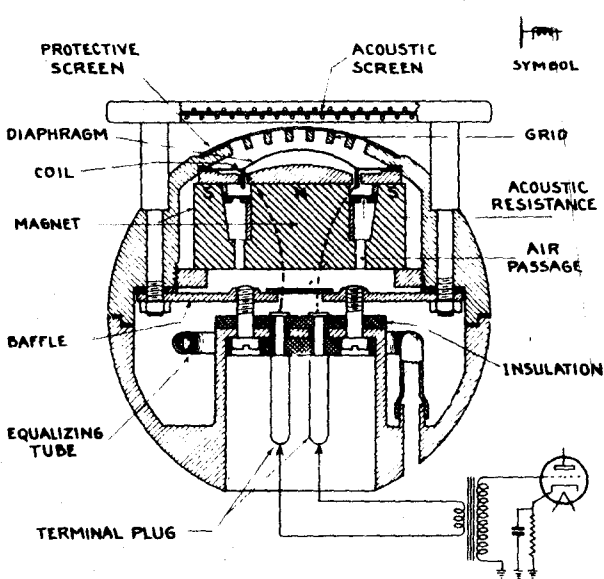

CRYSTAL MICROPHONE - SOUND CELL TYPE

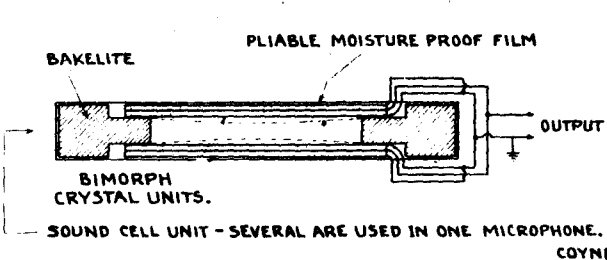

COYNE.

AUDIO AMPLIFIER.

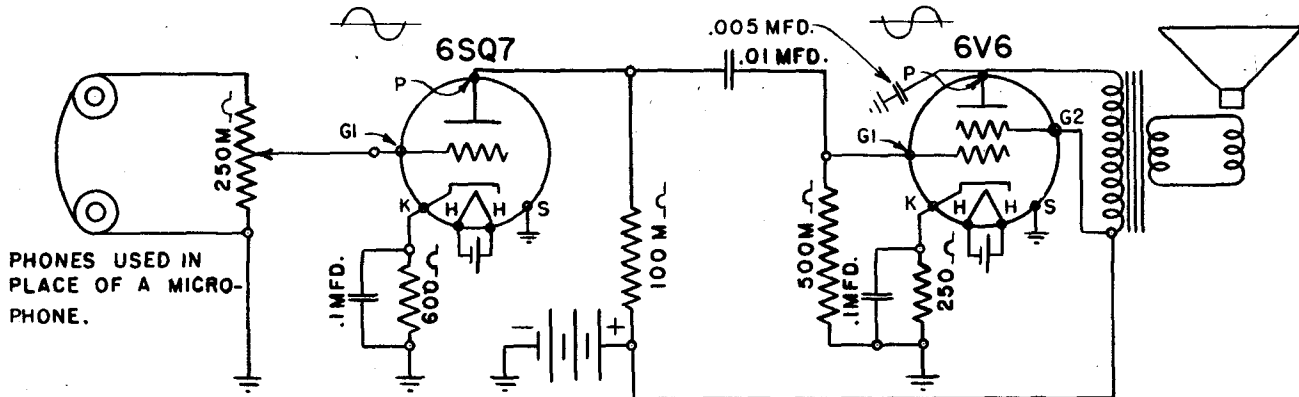

PHONES USED IN PLACE OF A MICROPHONE.

Measure all voltages. Write meter readings directly below corresponding values on the diagram. (Mark neatly in red pencil)

All voltages are D. C. unless otherwise specified. D. C. voltage and A. C. plate voltage of rectifier tube are to be taken from the chassis to the points indicated; other A. C. voltage across points shown.

The meter readings should approximate the indicated values within plus or minus 10%.

CAUTION - DO NOT CONNECT METER ACROSS THE HIGH VOLTAGE SECONDARY WINDING.

BOTTOM VIEW OF TUBE BASES.

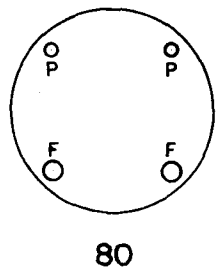

80

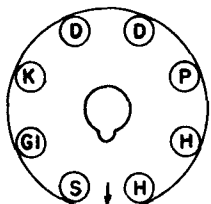

6SQ7

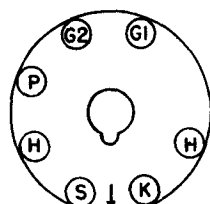

6V6

- 1ST. CIRCUIT.
- 2ND. "
- 3RD. "
- 4TH. "
- 5TH. "

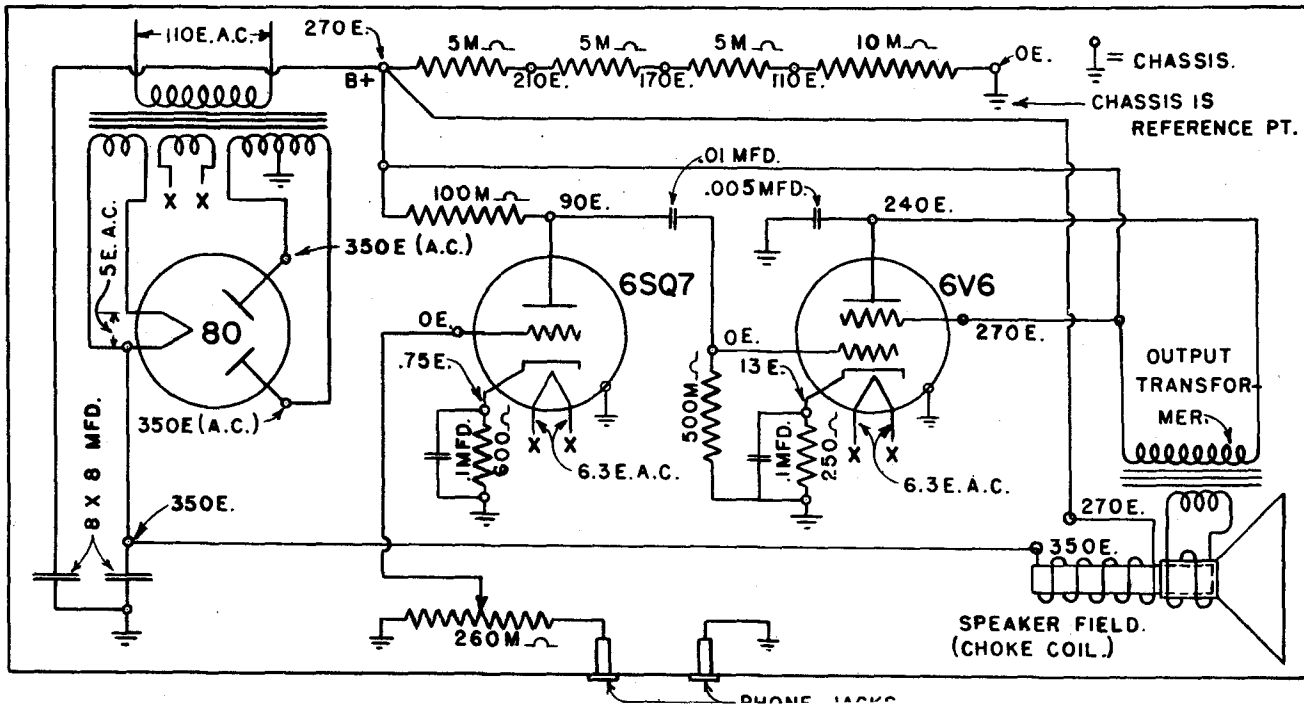

SPEAKER FIELD. (CHOKE COIL.)

PHONE JACKS

POWER TRANSFORMER

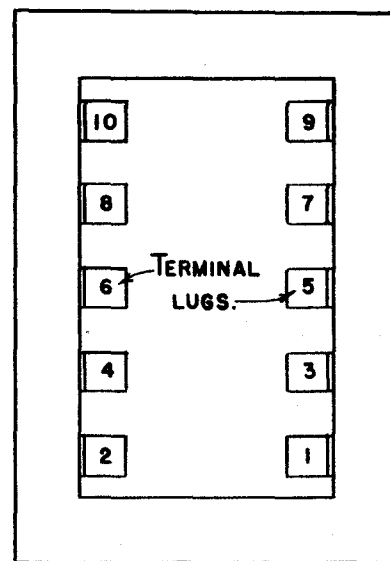
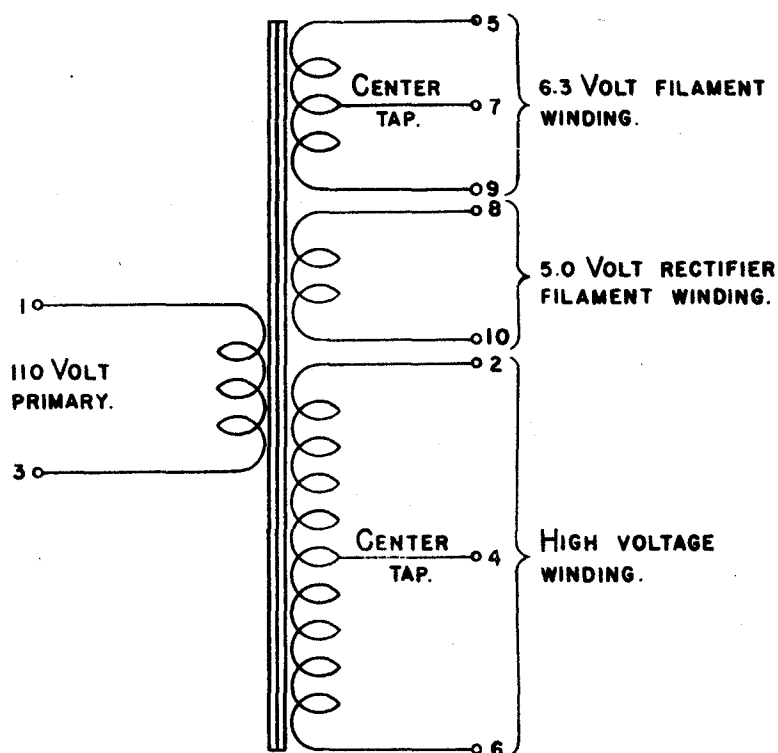

BOTTOM VIEW OF TRANSFORMER.

PURPOSE

A transformer is a device designed to change an A.C. voltage - or a periodically varying D.C. voltage - from one value to another without any change in frequency.

CONSTRUCTION

The ordinary transformer consists of a primary winding - connected to the source of energy - a laminated iron core, and one or more secondary windings. Theoretically, any winding may be used as the primary, provided the proper voltage and frequency be applied to it. The laminated iron core serves as an efficient means of magnetically coupling together the primary and secondary windings.

ACTION

A periodically varying voltage applied to the primary winding produces a varying current that in turn develops a varying flux in the iron core. This varying flux cuts all windings, inducing in each of them a voltage proportional to the number of turns.

TURNS RATIO

The ratio of the primary voltage to any secondary voltage is practically equal to the ratio of the primary turns to the secondary turns as indicated by the formula:

$$\frac{E_p}{E_s} = \frac{N_p}{N_s}$$

ACTION UNDER LOAD

The voltage induced in the primary winding by the growing and dying core flux is practically equal to the applied voltage; moreover, this induced voltage directly opposes the applied voltage; therefore, the current drawn from the supply is small.

When a secondary circuit is completed, current circulates around the iron core in the opposite direction to the primary current, reducing the core flux and the counter voltage of the primary. This action causes the current in the primary to vary in accordance with the secondary load. It is through this action that the transformer automatically adjusts itself to changes in secondary load.

PUBLIC ADDRESS INPUT CIRCUITS

THREE CHANNEL SINGLE ATTENUATOR MIXER CIRCUIT

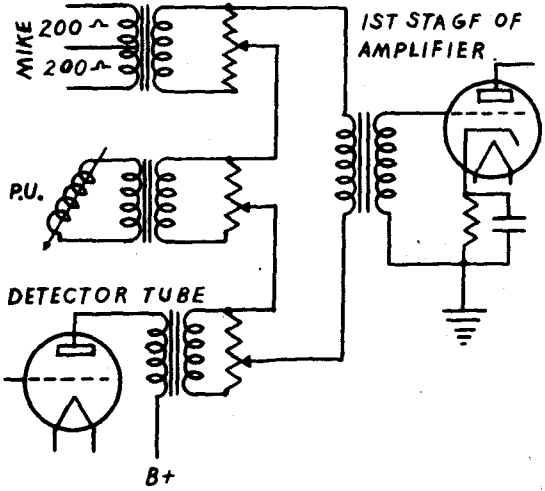

FOUR CHANNEL DOUBLE ATTENUATOR MIXER CIRCUIT

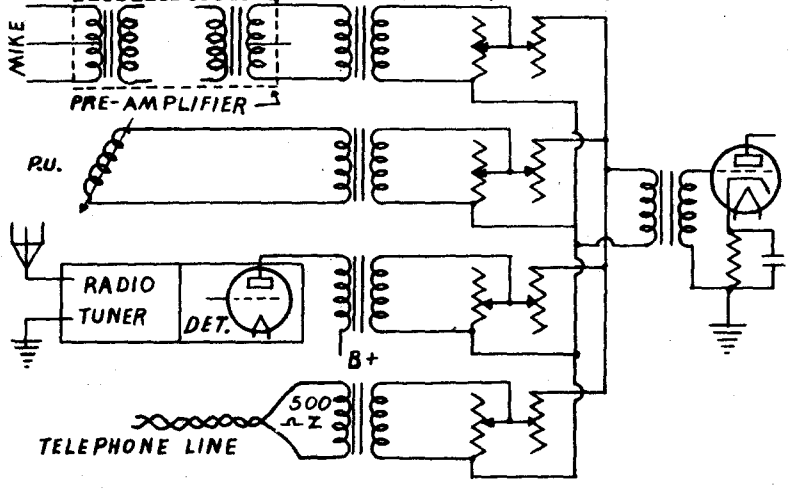

TWO CHANNEL T-PAD ATTENUATOR MIXER CIRCUIT

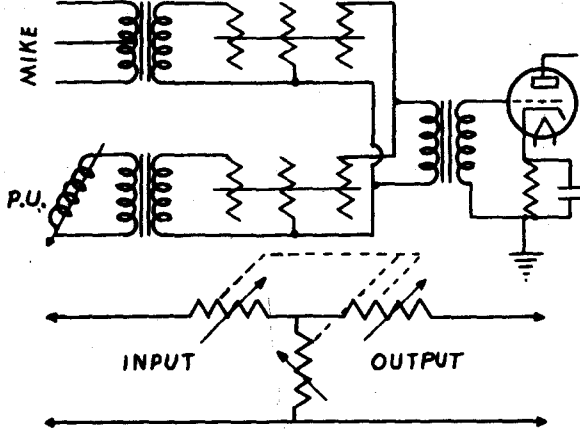

ELECTRONIC MIXER

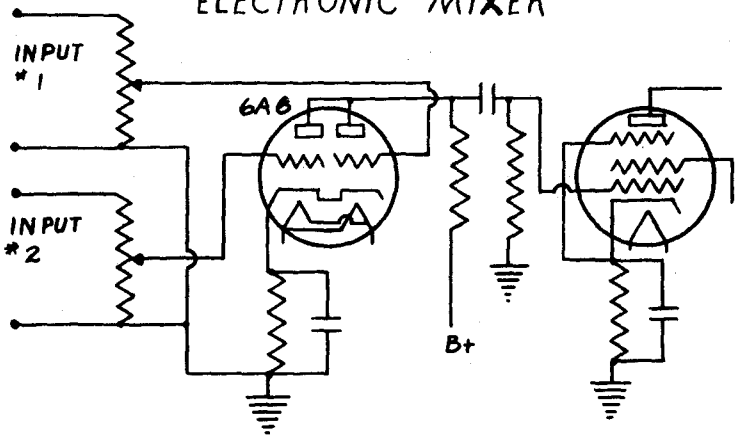

THREE CHANNEL INPUT- ELECTRONIC MIXER AND FADER

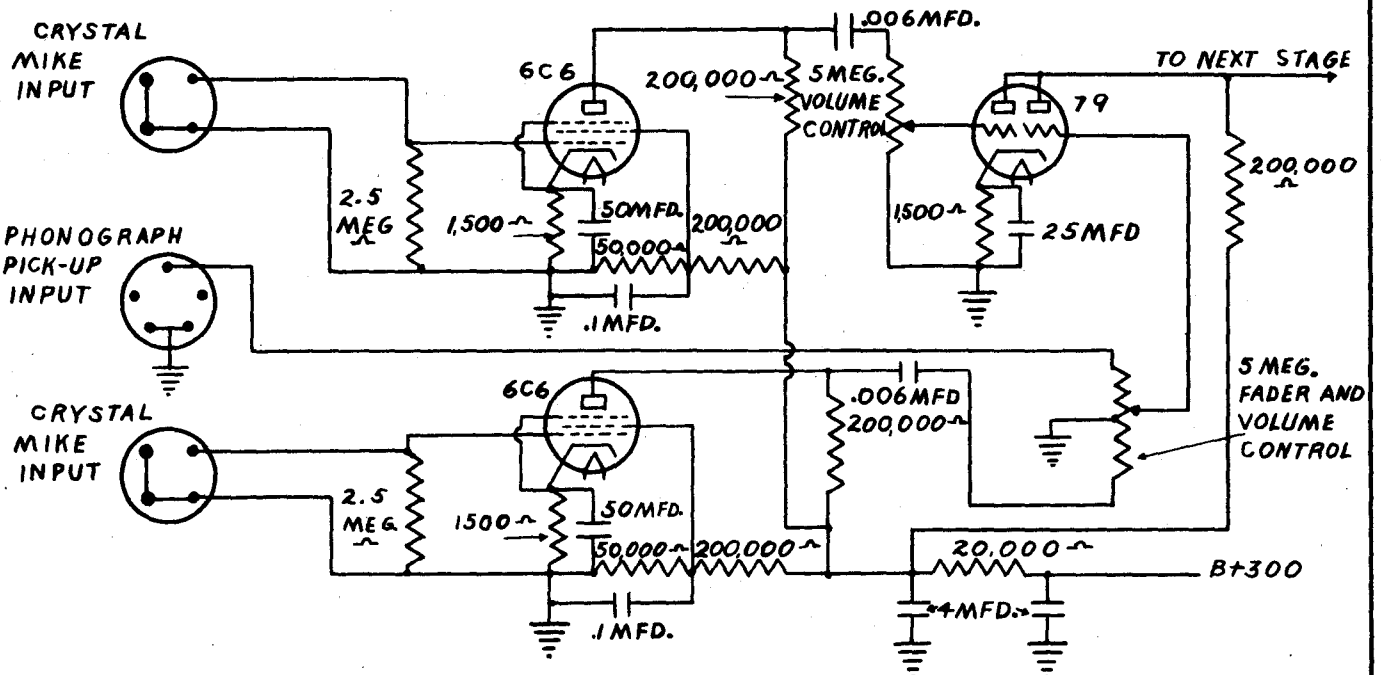

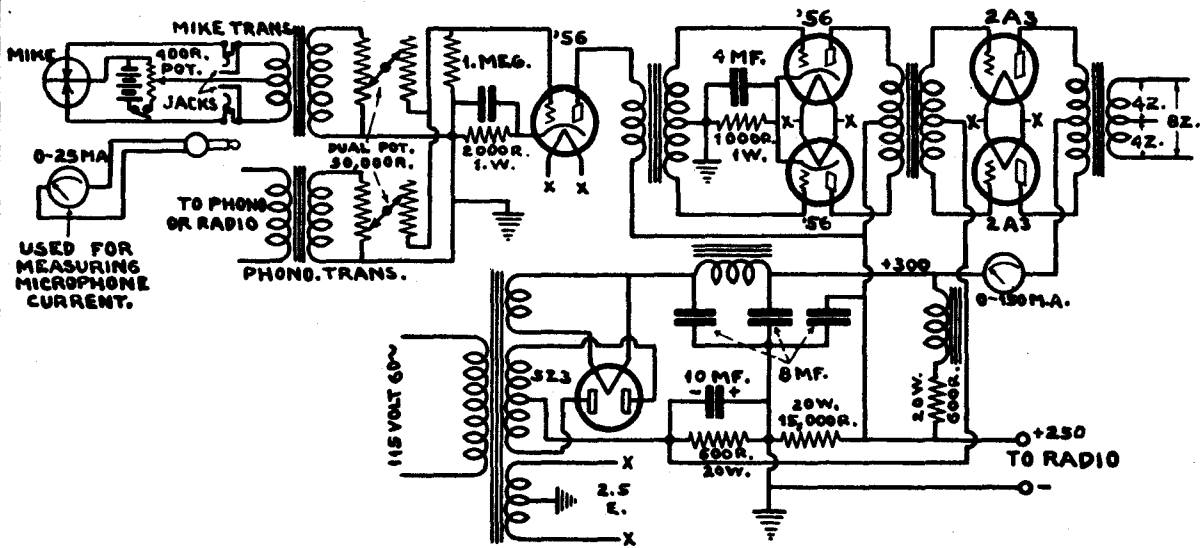

PUSH-PULL CLASS "A" MODERATE POWER PUBLIC ADDRESS OR HOME RADIO AMPLIFIER. THE FREQ. RESPONSE CURVE AT 15 WATTS OUTPUT VARIES LESS THAN ONE DECIBEL FROM 60 TO 7,000 CYCLES. IT HAS AN OVERALL GAIN OF 68.76 DB. FROM THE PHONO. INPUT, WHILE A HIGHER GAIN IS OBTAINED FROM THE MICROPHONE INPUT.

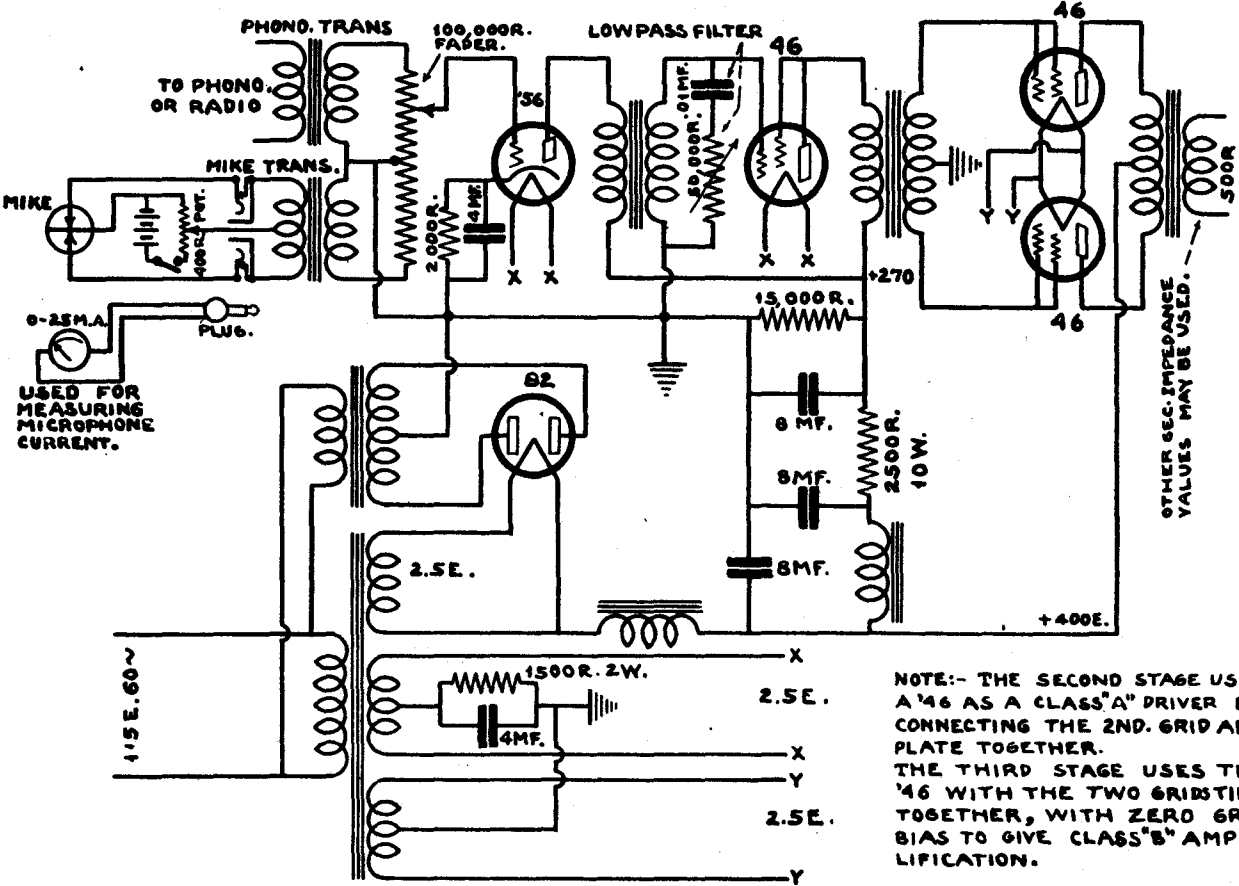

CLASS "B" 20 WATT AMPLIFIER. IN ORDER THAT FULL POWER MAY BE OBTAINED WITH NEGLIGIBLE DISTORTION, IT IS IMPORTANT THAT CAREFULLY DESIGNED COUPLING TRANS. BE USED AND THAT THE POWER SUPPLY UNIT HAVE EXTREMELY GOOD VOLTAGE REG. THE AVERAGE GAIN IS APPROX. 42DB. THIS AMP. SHOULD NEVER BE OPERATED WITHOUT A LOAD CONNECTED TO THE SEC. OF THE OUTPUT TRANS. AS IT MIGHT CAUSE THE DISTRUCTION OF EITHER THE TUBES OR THE OUTPUT TRANS. OR BOTH. IF ONLY ONE OR TWO SPEAKERS ARE CONNECTED THE VOL. CONT. MUST BE KEPT LOW OR THE SPEAKERS MAY BE PERMANENTLY INJURED BY THE TREMENDOUS POWER AVAILABLE.

40 Watt P.A. Amplifier.

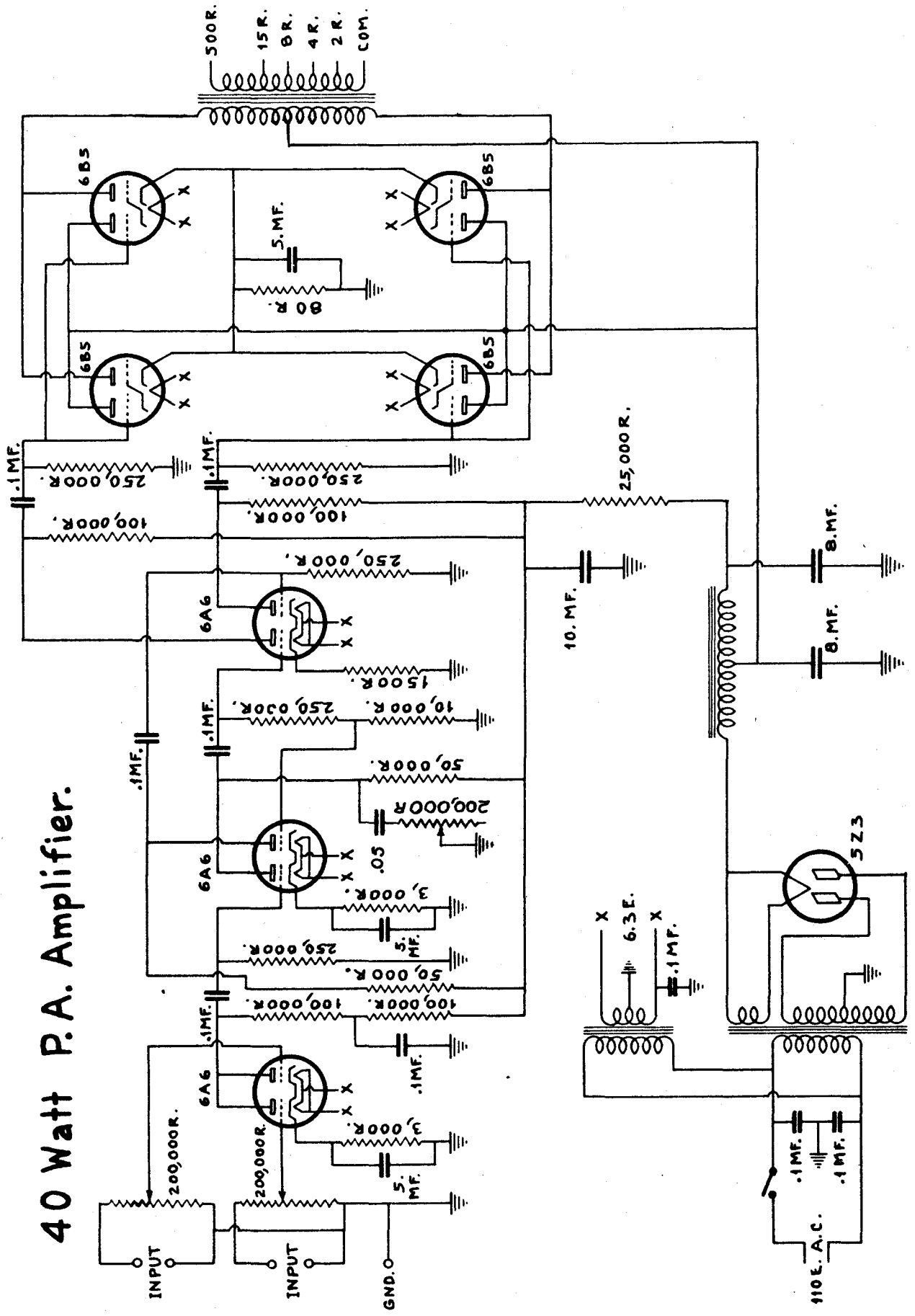

SOUND RECORDING

FIG. 1 COMPARISON OF THE STEPS IN FILM AND DISC SOUND RECORDING.

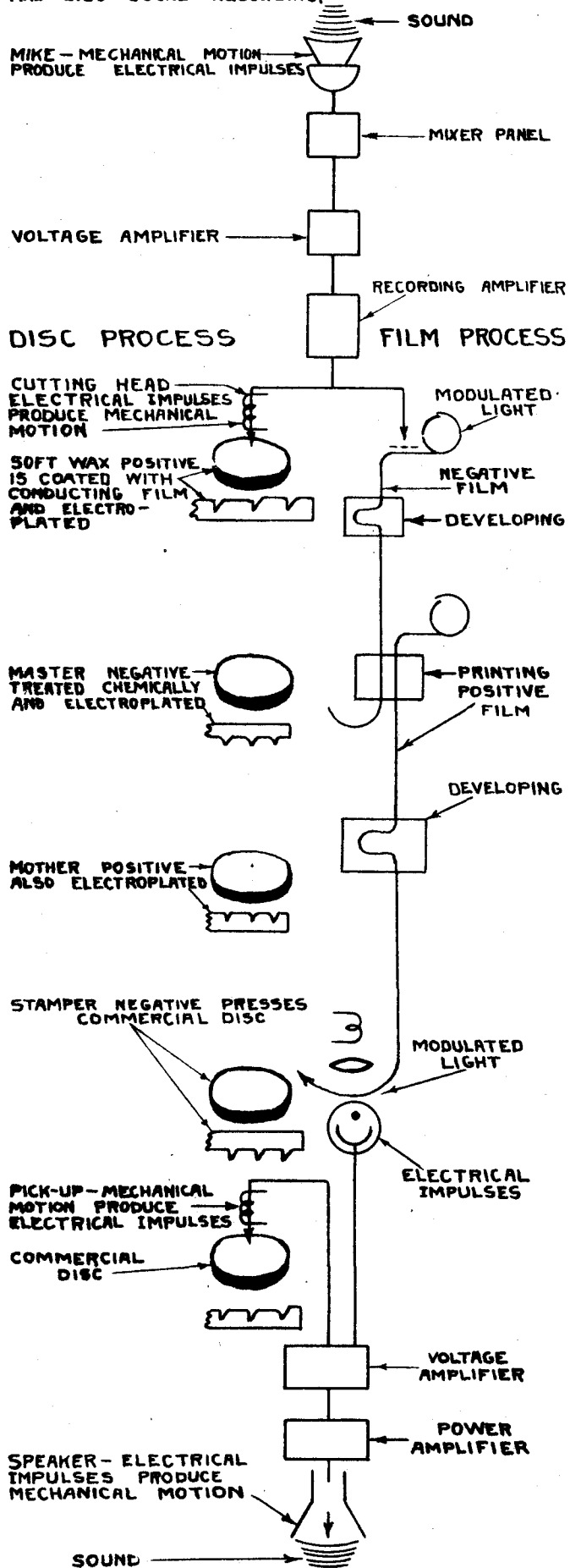

FIG. 2 SCHEMATIC LAYOUT OF RECORDING SYSTEM.

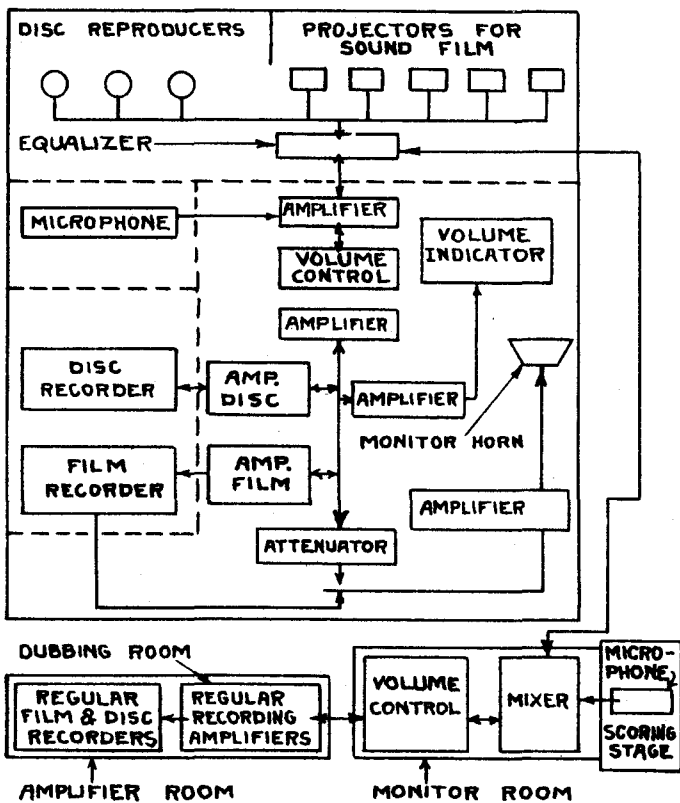
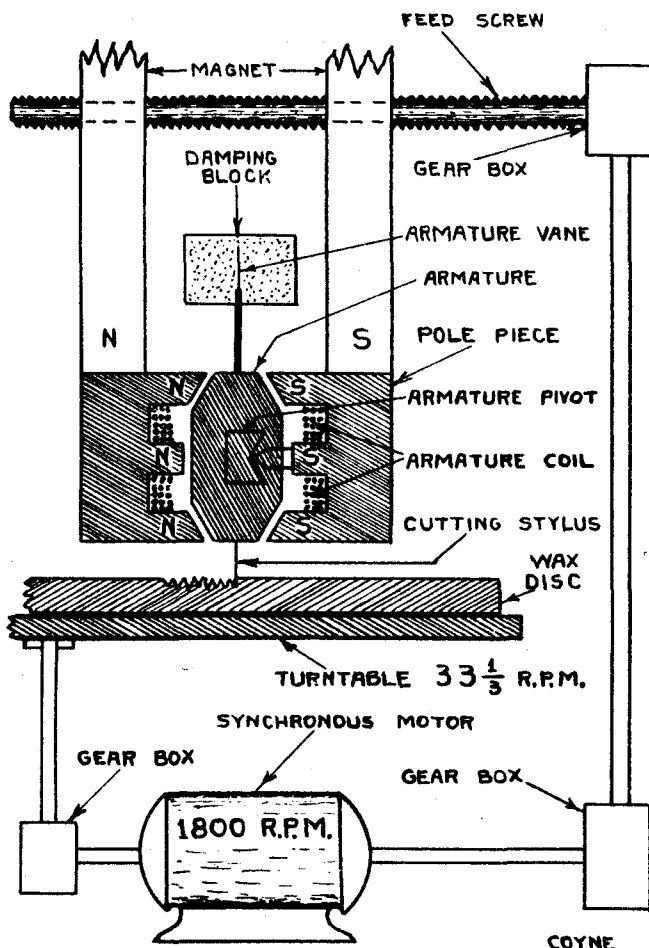

FIG. 3 SKETCH OF CUTTING-HEAD ON TURNTABLE.



SOUND RECORDING

FIG. 1 SOUND FILM SHOWING SEVERAL TYPES OF RECORDING.

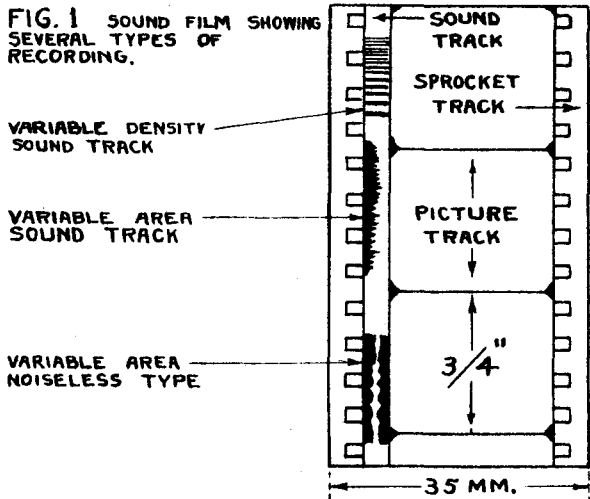
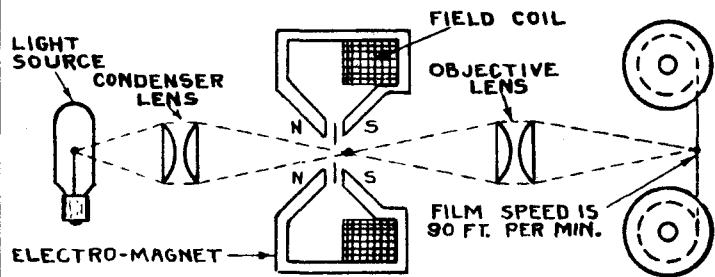

FIG. 2 RIBBON LIGHT VALVE SYSTEM OF RECORDING VARIABLE DENSITY SOUND TRACK



SIGNAL CIRCUIT- LIGHT PASSES BETWEEN RIBBONS WHICH ARE LOCATED IN A STRONG MAGNETIC FIELD,

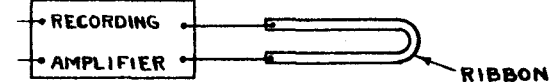

FIG. 3 R.C.A. PHOTOPHONE SYSTEM OF RECORDING VARIABLE AREA SOUND TRACK

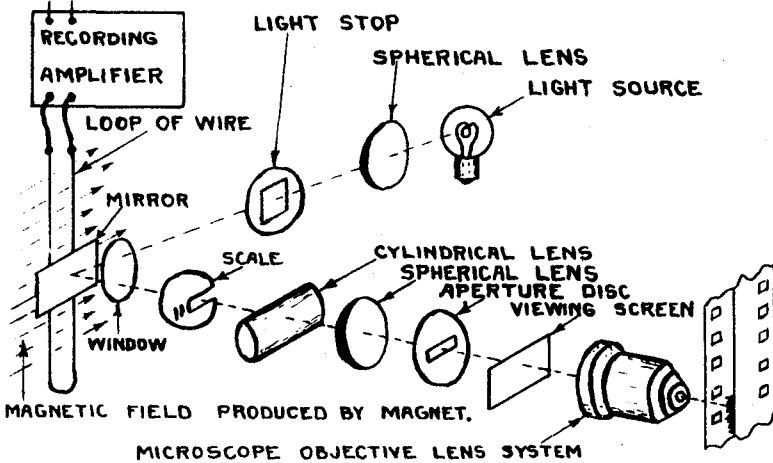

FIG. 4 MODULATED LIGHT BEAM SYSTEM OF RECORDING VARIABLE DENSITY SOUND TRACK

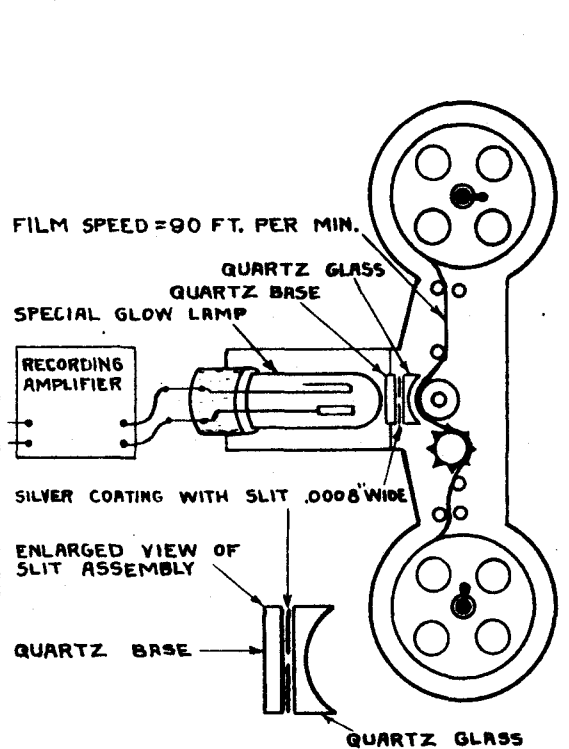

FIG. 5 NOISELESS RECORDING SYSTEM

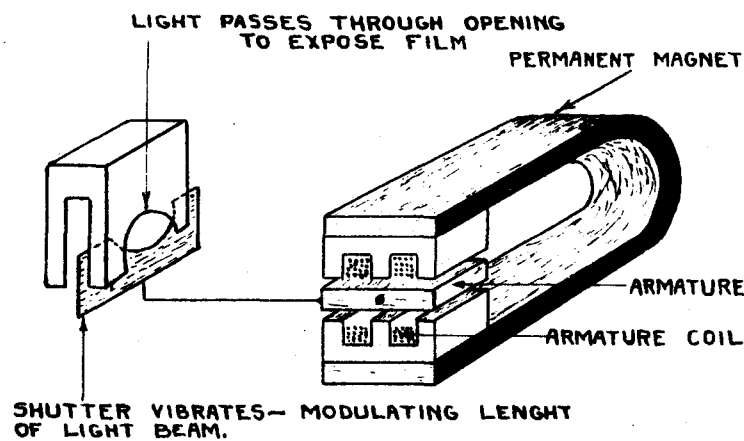

FIG. 6 PRINTING MACHINE

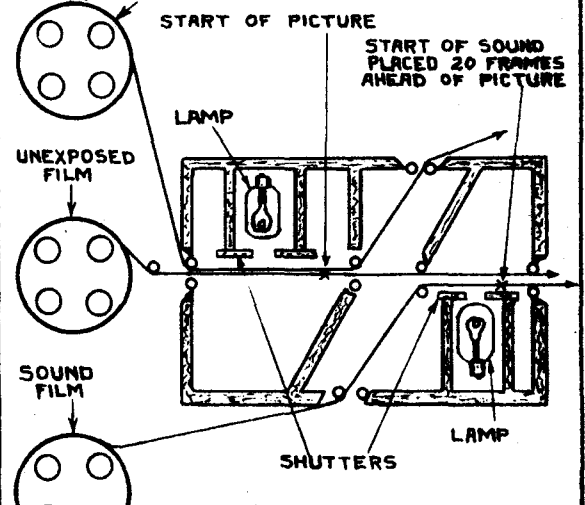
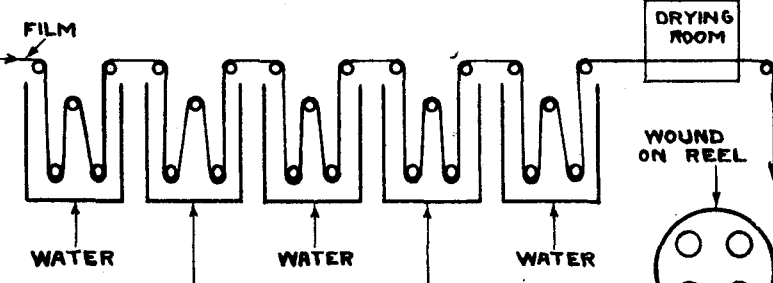
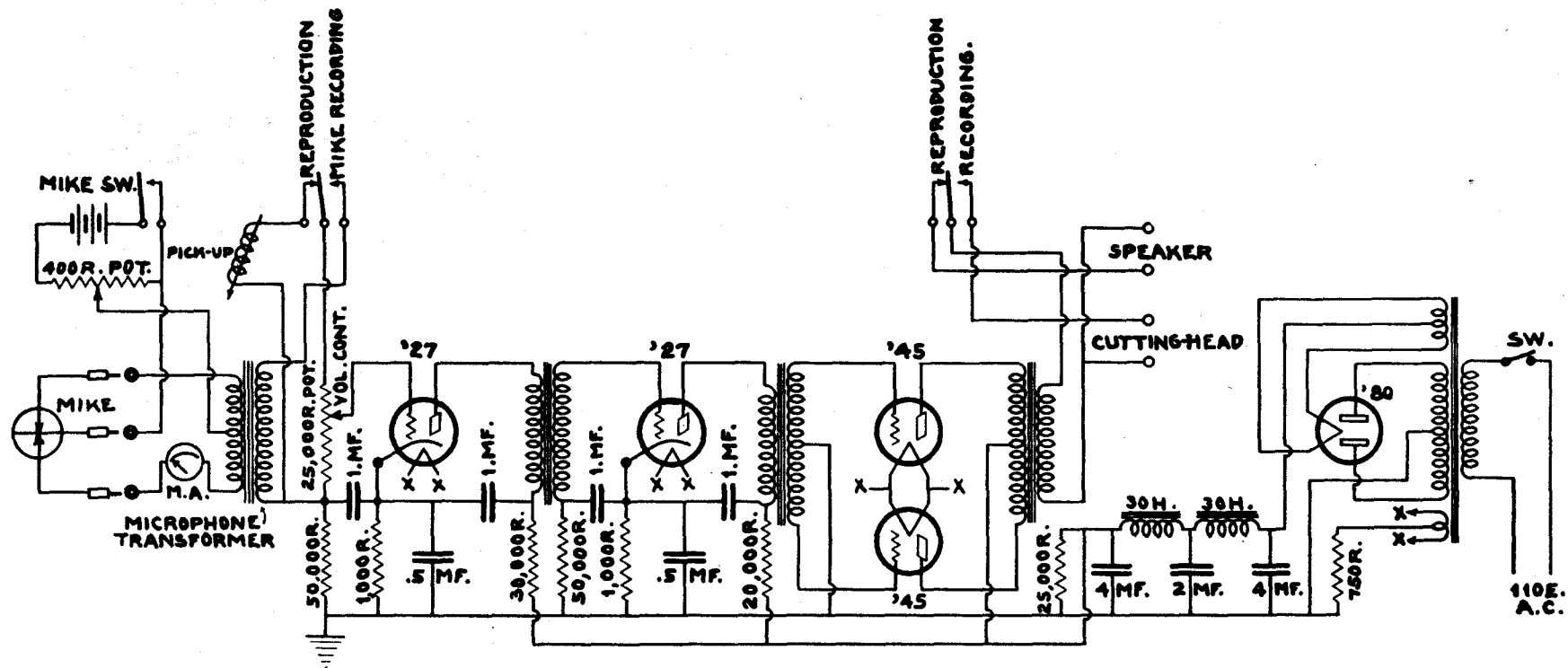

FIG. 7 DEVELOPING TANKS





COMPLETE WIRING CIRCUIT OF AMPLIFIER AND RECORDING APPARATUS NEEDED FOR INSTANTANEOUS SOUND RECORDING.

MICROPHONE CURRENT READINGS FOR EACH BUTTON ARE OBTAINED BY REVERSING THE POSITION OF THE PLUG OF THE THREE-CONDUCTOR CORD. THE SPEAKER AND CUTTING-HEAD MUST HAVE THE SAME IMPEDANCE. THIS IMPEDANCE MUST MATCH THE IMPEDANCE OF THE SECONDARY OF THE OUTPUT TRANSFORMER. THE PHONOGRAPH PICK-UP MUST BE A HIGH IMPEDANCE TYPE. THE VERY THOROUGH BY-PASSING MAKES THE OPERATION OF THIS AMPLIFIER VERY STABLE. IT CAN BE BUILT INTO A PORTABLE CABINET. THE "B" SUPPLY MUST BE SHIELDED FROM THE AMPLIFIER.

BLOCK LAY-OUT AND SOUND AMPLIFIER CIRCUITS OF SOUND PROJECTOR.

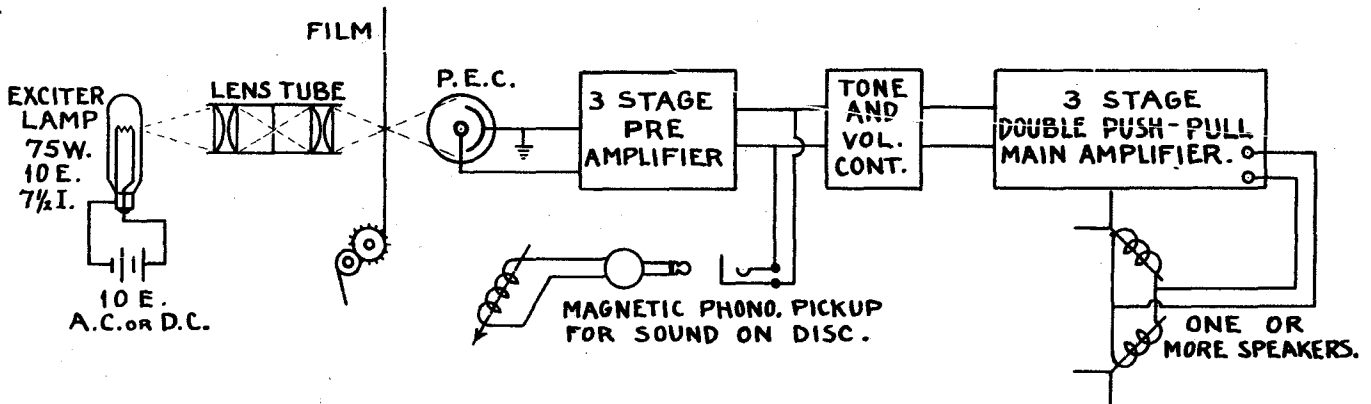

PRE AMPLIFIER CIRCUIT

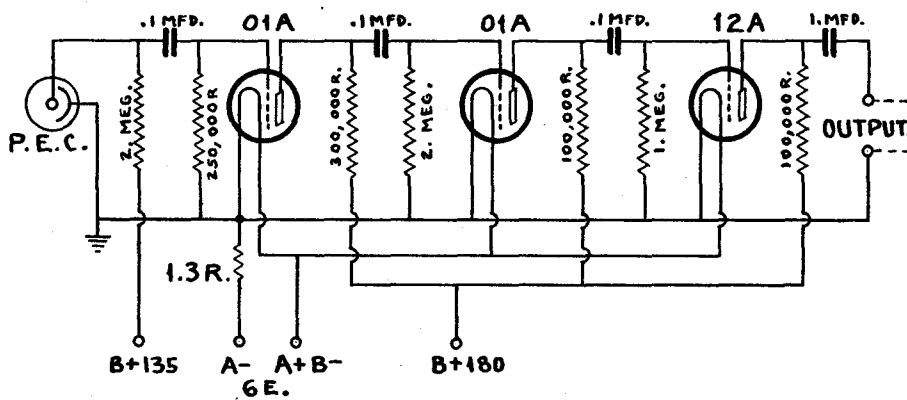

TONE & VOL. CONT.

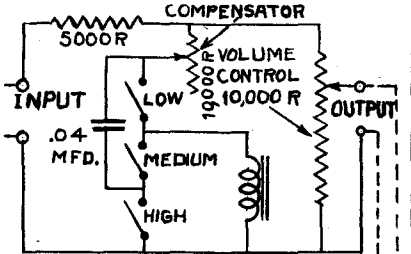

MAIN AMPLIFIER.

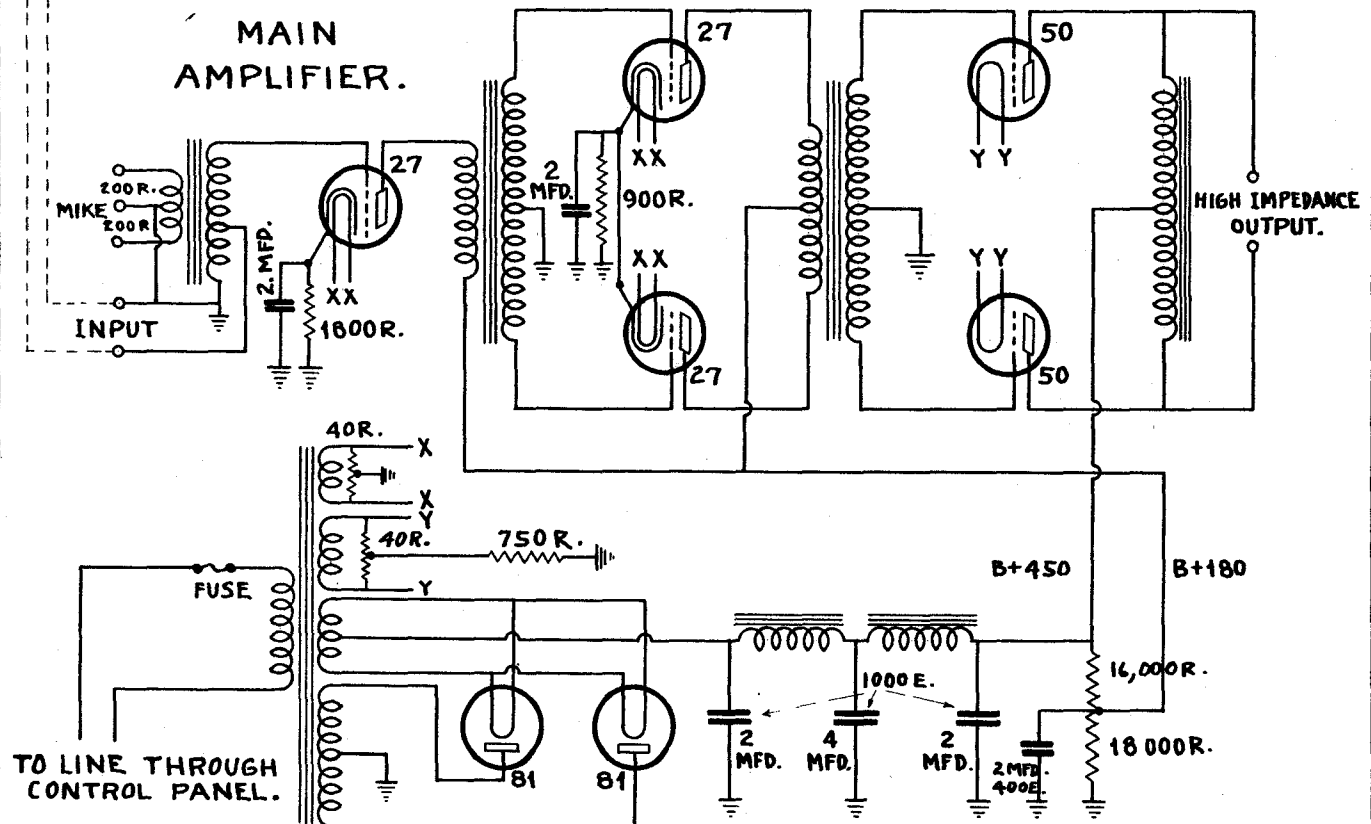
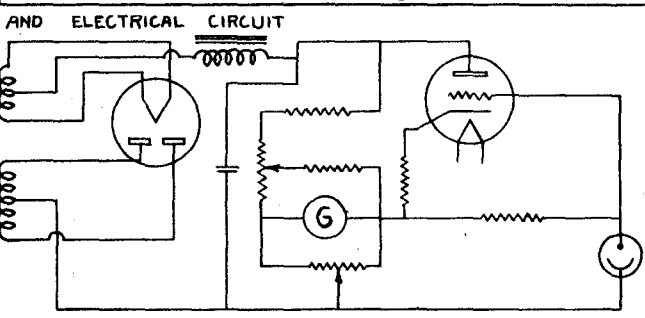
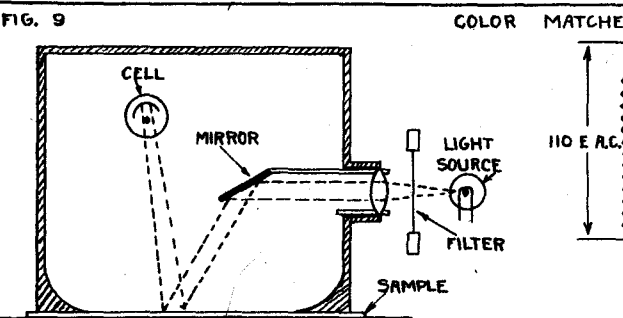
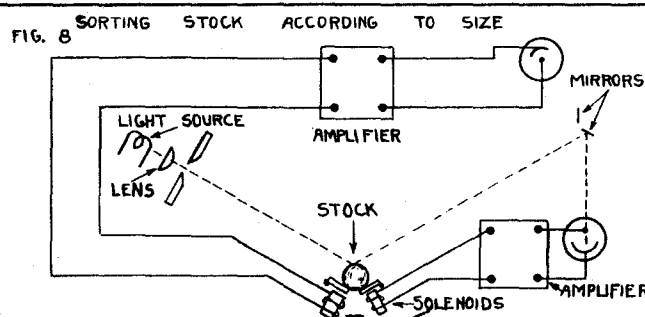
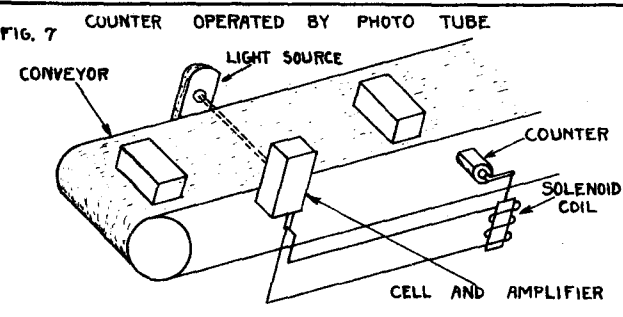
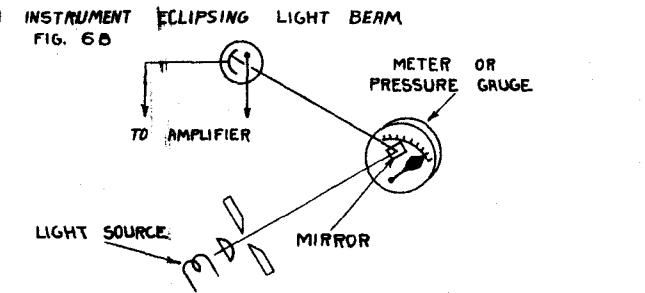
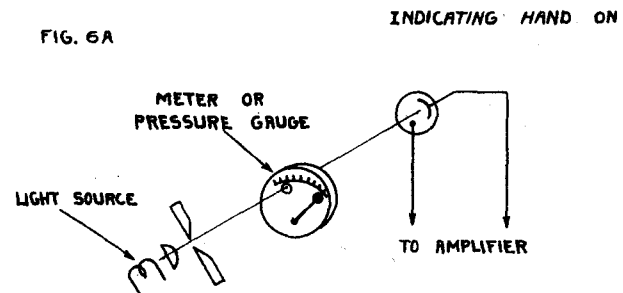
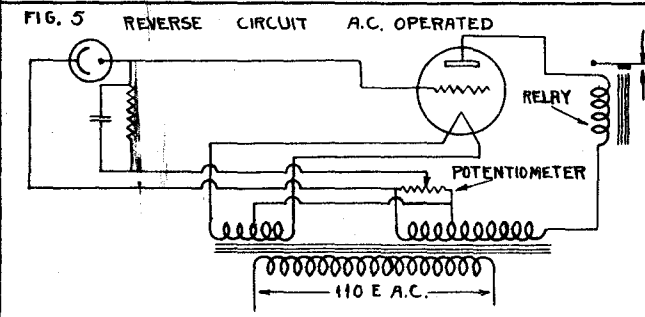
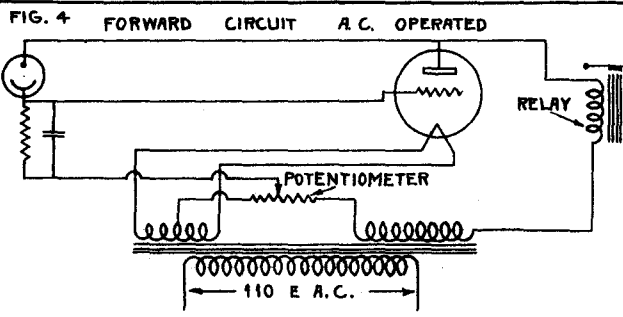
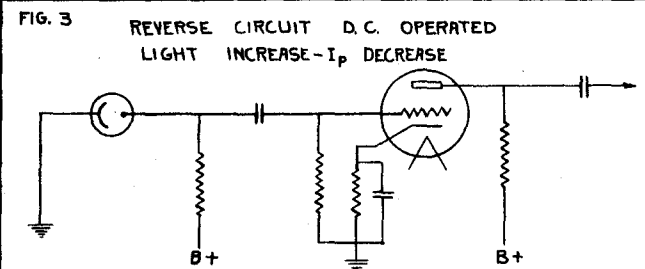
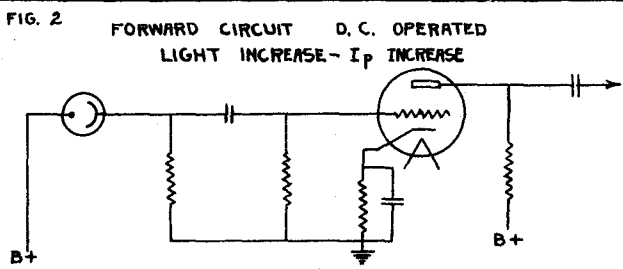
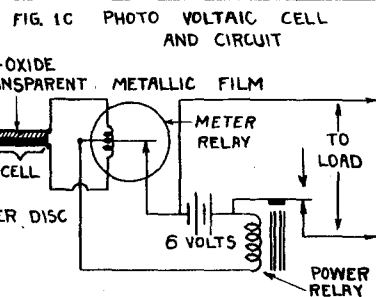
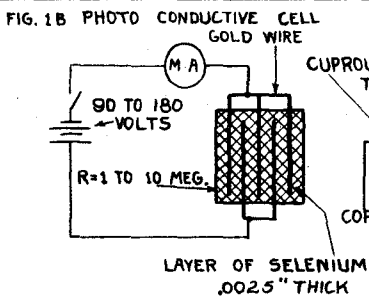
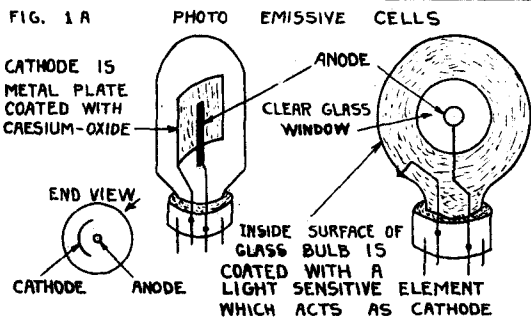

PHOTO ELECTRIC CELLS, CIRCUITS AND APPLICATIONS



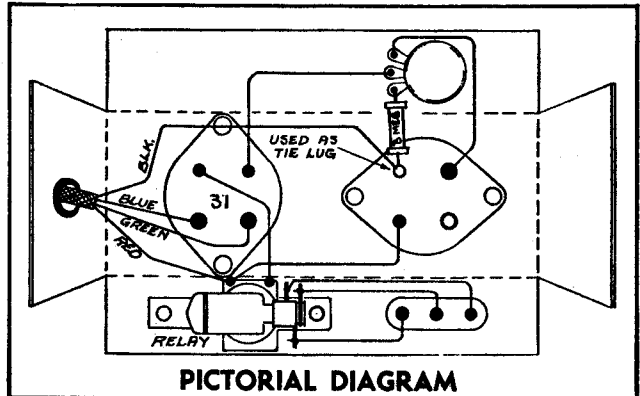
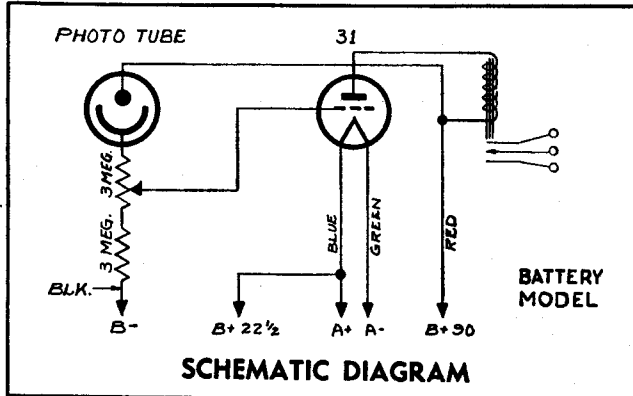
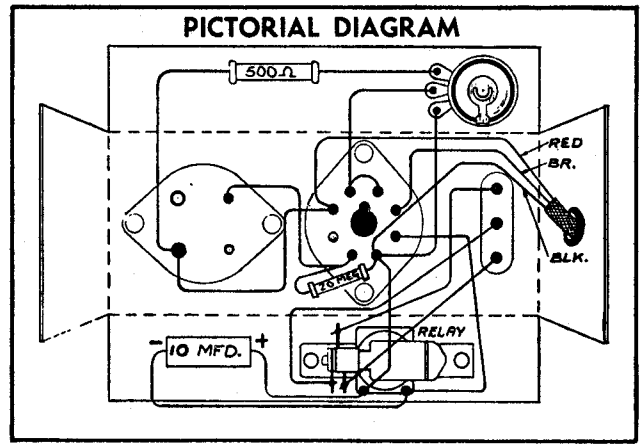
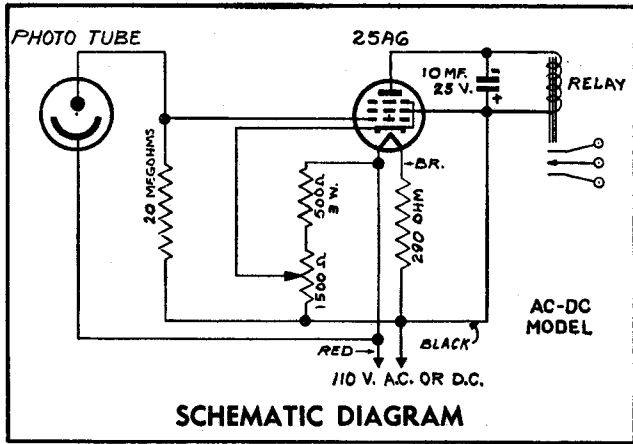
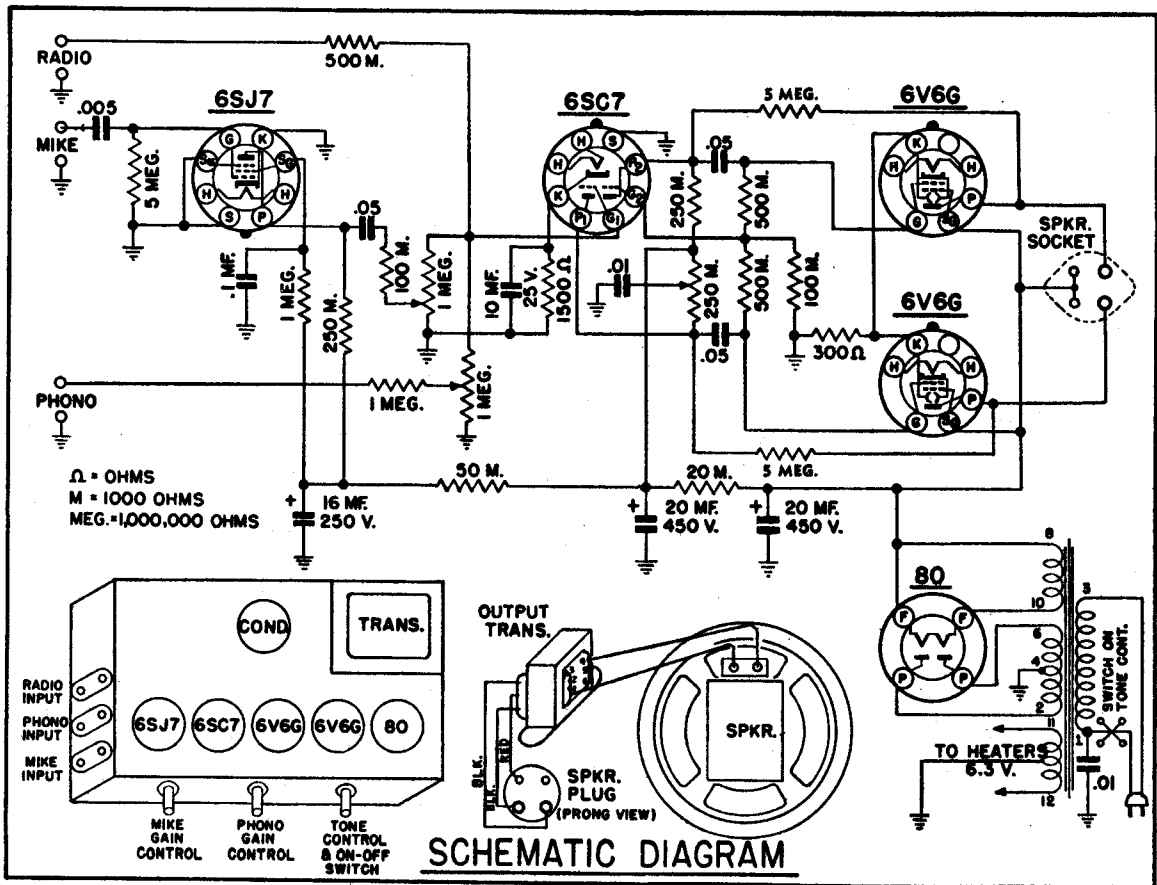

Photo-Electric Cell Circuits



CONSTRUCTION OF PHOTO-ELECTRIC CELL RELAY FROM A.F. TRANSFORMER.

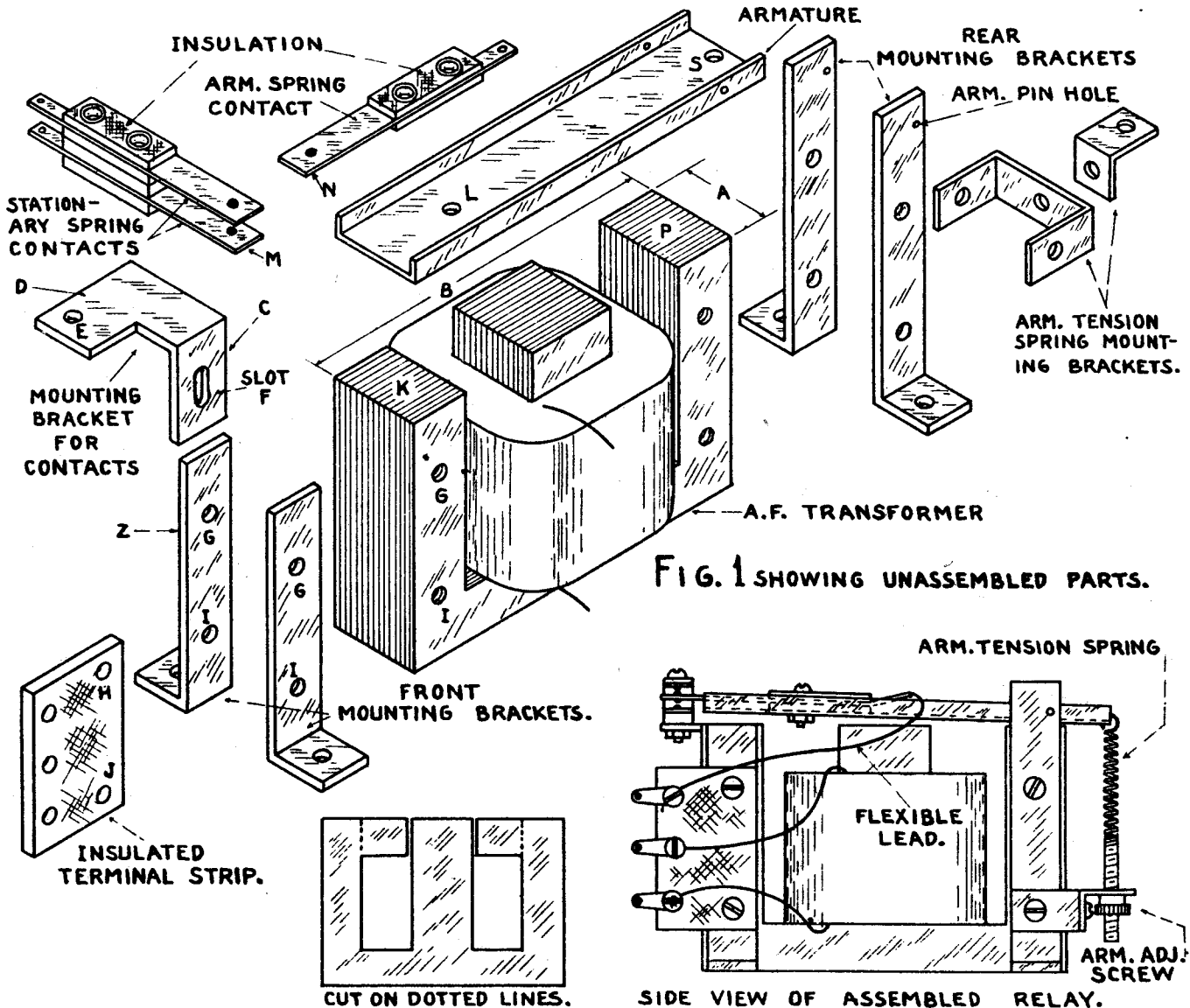
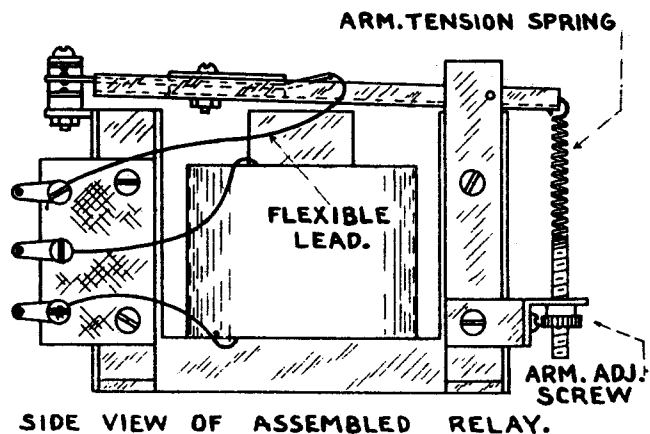
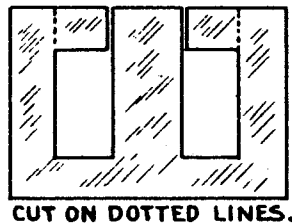

FIG. 1 SHOWING UNASSEMBLED PARTS.



SIDE VIEW OF ASSEMBLED RELAY.



CUT ON DOTTED LINES.

FIG. 3

RELAY DESIGNED BY JOHN P. HANAN.

COYNE ELECTRICAL SCHOOL

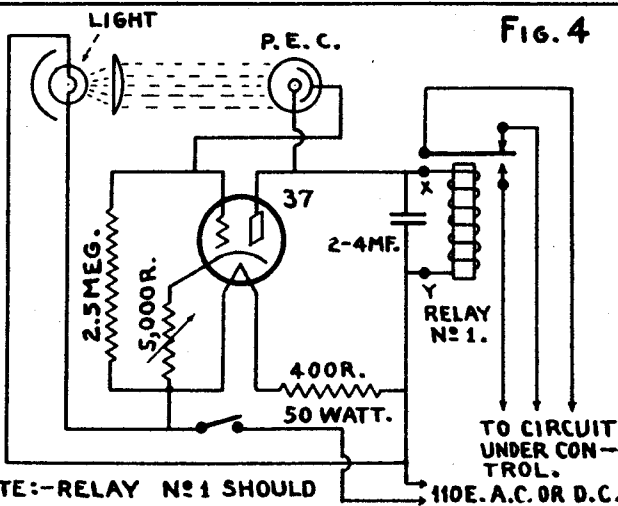
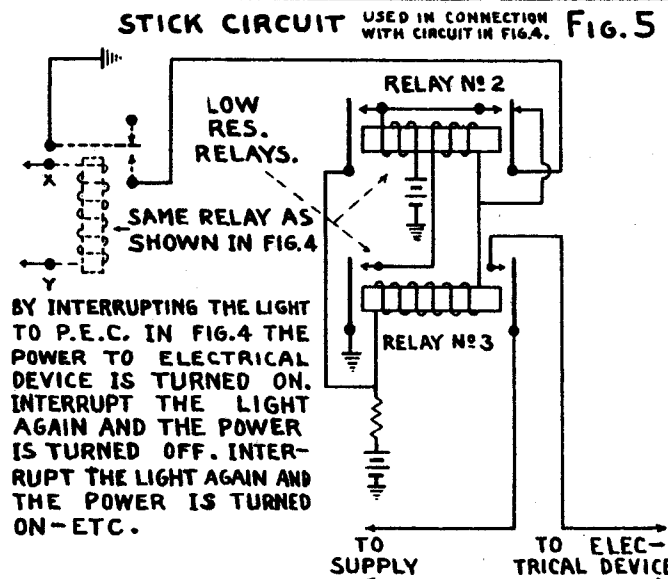

FIG. 4

NOTE:--RELAY No. 1 SHOULD BE A HIGH RESISTANCE RELAY OR A RELAY MADE ACCORDING TO SPECIFICATIONS. PHOTO-ELECTRIC CELL RELAY CIRCUIT.



STICK CIRCUIT USED IN CONNECTION WITH CIRCUIT IN FIG. 4. FIG. 5

BY INTERRUPTING THE LIGHT TO P.E.C. IN FIG. 4 THE POWER TO ELECTRICAL DEVICE IS TURNED ON. INTERRUPT THE LIGHT AGAIN AND THE POWER IS TURNED OFF. INTERRUPT THE LIGHT AGAIN AND THE POWER IS TURNED ON-ETC.

I N S T R U C T I O N S

Photo Cell Relay Assembly

Read complete instructions first before any work is started. When the instructions refer to any particular part, examine that part very closely so as to become familiar with each part and to enable you to use the proper size drill for various holes.

Remove transformer coil and laminations from case. Pull out one lamination at a time until all are removed from coil, being careful not to damage the windings. Then cut the laminations with tin snips as indicated in Fig. 3. Replace laminations in coil with cut-out section of each facing in the same direction as shown in Fig. 1.

Form mounting brackets next. If laminations have mounting holes, use one as a template to mark position of holes in brackets. If laminations do not have holes, place laminations between rear brackets in proper position and clamp in vise in such a way that one hole can be drilled through brackets and core with one drilling. Place screw through hole and draw nut down before removing from vise. Then drill other hole and insert bolt in same manner. Mount front brackets next, following same procedure used on rear brackets.

Measure distance "A" (thickness of core). The width of armature after it has been shaped must be about 1/16 inch less than distance "A." The armature must be free to move without touching brackets. Measure distance "B" and make length of armature 1/2 inch longer. Cut a piece of cardboard (furnished with kit) correct size to fit over end of core marked "P" and glue in place. Next place armature over laminations with front end of armature even with front end of laminations marked "K." This will enable you to locate position of armature pin hole in one bracket, which must be as near to the back edge of brackets as possible. Mark height of hole which must be in middle of armature lift. Now remove both brackets, mark where you wish to drill hole with center punch on the one bracket, place in vise, being careful to have holes in both brackets exactly opposite, then drill armature pin holes with one drilling, keeping drill at right angles to brackets. Replace brackets and armature over pole faces, with front end of armature even with front end of laminations. Hold armature tightly against pole faces while a scratch awl is passed through armature pin holes in brackets to mark their position on both sides of armature. These holes should now be drilled, the cardboard spacer over pole face "P" removed and the armature temporarily mounted by passing armature pin through all pin holes. This pin may be left long enough to be bent over on the ends for permanent mounting of armature.

The armature spring contacts and insulators should be assembled next and placed on end of armature so that end of contact lever is one-half inch from front end of armature. Mark position of hole "L" in armature. This hole should fall between the center pole face and front end pole face "K" so that a brass nut on the mounting screw will not come in contact with either pole face. The armature should be removed while this hole and the hole "S" in the rear of armature are drilled. Mount armature spring contact on armature and remount armature permanently.

Cut out mounting brackets for stationary contacts, making each leg of bracket much longer than required. The right angle bend in leg "C" should be made next. Determine position of bend by holding stationary spring contacts on leg "D." Then hold bracket against bracket "Z" until stationary contacts line up with armature spring contact. This gives a rough height of bend in leg "C," but the holes in each leg can now be drilled in such a position that the contacts will line up properly. To find position of holes, remove screw passing through "G" and place leg "C" flat against bracket "Z." Place stationary spring contacts on leg "D" and shift position until contacts line up with each other as shown in Fig. 2. Hold firmly while position of hole "E" is marked. Drill this hole and mount stationary contacts on leg "D." To locate position of slot "F," replace leg "C" as before, in such a position that the switch contacts line up again as shown in Fig. 2. Pass a thin nail through hole "G" to mark leg "C." Drill two holes—one above and one below the scratch mark, close together, and file out wall between the two holes to make slot "F." This gives a slot which will permit the raising or lowering of the bracket so that the stationary contacts can be shifted to give proper movement of armature. Cut off each leg to proper length. Cut and drill holes in insulating terminal strip and then mount bracket and terminal strip by passing screw through holes "H," "G" and slot "F." Remove screw in hole "I," swing terminal strip until holes "I" and "J" line up, then insert screw and tighten nut.

Extreme care should now be used to get switch contacts in proper alignment. This is done by adjusting nut over slot "F" and also nut on screw passing through armature hole "L" to just the right tightness so that when contacts and brackets are removed, they will remain in new position. The mounting brackets for the stationary contacts should now be raised until there is a clearance of about .001 of an inch between pole face "K" and armature. The armature will be raised when the spring "M" makes contact with spring "N." Be sure that all spring contact points line up with each other and meet properly when the armature is moved up and down and that the armature never comes in contact with the pole face "K."

The armature tension spring should now be assembled as shown in Fig. 2. The armature adjusting screw is attached to the tension spring by screwing the spring over the threads.

If both the primary and secondary windings are good, they may be used by connecting the two in series. The polarity of the two windings must be such that they aid each other. This can be checked by connecting them together temporarily until the relay is put into service. Then reverse connections to one winding, not both, only until you find the connection that will cause the armature to pull down with the maximum resistance in the cathode circuit. Either one of the windings may be used individually.

The flexible wire leading from the armature spring contact must be sufficiently loose so that it does not interfere with the free movement of the armature.

TWO STAGE PHOTO-RELAY (LIGHT "ON" RELAY DE-ENERGIZED)

This photo-relay provides a sustaining and a stick circuit with relay contacts, capable of carrying 1500 watts, Four different devices may be controlled at one time. An electric lamp bulb should be plugged into the different outlets, one at a time, while checking for proper operation.

CAUTION: The metal housing which protects the relay must always be in place while wiring and testing this unit. Extreme caution must be used when wiring the heater circuit. A single mistake in this circuit may cause the heaters to burn out. Never prod the wires or parts with your finger or any kind of insulated or metal tool while the power is on. Never catch hold of the two tubes at the same time while the power is on. Be sure to get the test chart checked before plugging into the power socket.

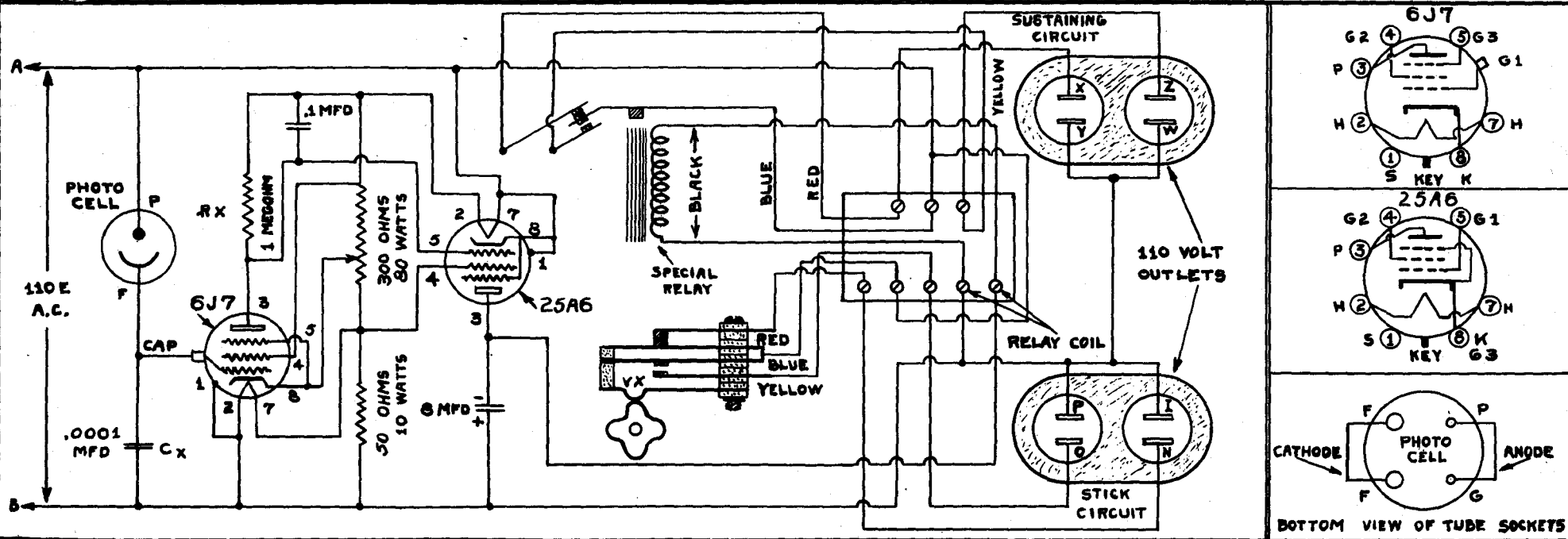

PHOTO-CELL UNIT RESISTANCE TEST CHART

TUBE	HEATER TO HEATER	K to A	K to B	SUP. G to A	SUP. G to B	P to A	P to B	C.G. to A	C.G. to B	S.G. to A	S.G. to B
6J7							SHORT RX		SHORT CX		
25A6									SHORT RX		

	ARMATURE OPEN		ARMATURE CLOSED		VX IN NOTCH		VX OUT OF NOTCH		ANODE OF CELL TO A	A TO B TUBES OUT
	TO A	TO B	TO A	TO B	TO A	TO B	TO A	TO B		
X			X		O		O			
Y			Y		P		P		CATHODE OF CELL TO B	A TO B TUBES IN
W			W		T		T			
Z			Z		N		N		SHORT CX	

COPY

"ELECTRIC EYE" BURGLAR ALARMS

The author tells how the use of photoelectric equipment for industrial applications is a "natural" for the radio Serviceman. A practical application which Servicemen should find to be a money-maker is described, and the necessary construction details are supplied.

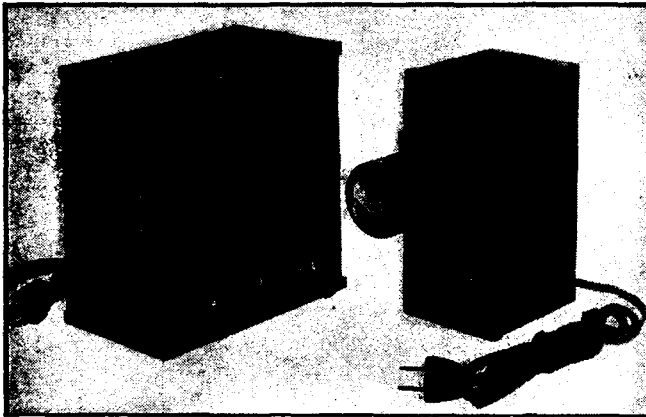

A commercial type of photoelectric equipment suitable for use in electronic burglar alarm systems. Left, photocell equipment in its housing; right, the exciter (light source). Photos—Worner Products Co.

THE progressive radio Serviceman and dealer is constantly seeking additional products to merchandise. Knocking at his door is a comparatively unexplored market. This new market is the use of photoelectric equipment in industrial applications.

This type of equipment, operating upon the electronic principle, is in theory not unlike the operation of radio receivers or amplifiers. It is a "natural" for the radio Serviceman, who should find it easy to understand the principles of operation.

By far the greatest application of photoelectric cell equipment is its use in burglar alarm systems. In this application the scheme essentially comprises a beam of invisible infra-red light whose continuity from light-sensitive cell to alarm relay must remain unbroken if the alarm is not to be given. When this invisible barrier is broken by an intruder, electrical apparatus is set into motion to give an audible or visible alarm in any chosen place continuously until reset. This beam should be invisible even in the dark, thus giving ample protection to the property which is covered by the device.

"BLACK LIGHT"

Let us consider the essential equipment in greater detail. A light source of the proper type is first required. Usually this takes the form of a low-voltage incandescent bulb of the automobile headlight type. The low voltage may be obtained from an A.C. source by means of a step-down transformer of the type carried by all radio supply houses. It should have a 6.3-volt output and sufficient carrying capacity for whatever type lamp you may use. An A.C.-D.C. type of light source merely is a small 115-V. projection lamp.

In an opening in the side of a light-tight box is a lens whose focal length is equal to the distance from the bulb to the mounting position of the lens. This will produce a nearly parallel beam of light. In back of this lens is placed a filter designed to absorb all light wavelengths below 7,200 Au. (Angstroms), allowing only infra-red or "black" light to pass.

The light source is placed so that the beam of light will pass by doors, windows and other points whose protection is required. For full protection around corners, mirrors are used. The sketch indicates the protection that may be obtained by the proper placement of mirrors. Obviously each installation requires ingenuity of thought, depending upon the circumstances.

"ELECTRIC EYE"

At the other end of the beam is a photocell relay unit, also housed in a light-tight box, and with the lens mounted in an opening on one side. The purpose of this lens is to concentrate the beam of light on to the "electric eye" itself, excluding all other light.

The photocell relay unit contains a caesium-coated photocell, a vacuum-tube grid-controlled rectifier with appropriate resistors and condensers, and the relay. The operation of the photocell unit is explained later on. In its simplest form the switching part of the relay is connected in series with

2 or 3 drycells and a bell which may be mounted anywhere.

The light beam on the photocell maintains the relay in an open position; and when the beam is interrupted, the relay contacts close, ringing the bell. In actual application, however, a drop-out type of relay is used so that when the beam of light is interrupted, the bell continues to ring even though the intruder may step out of the beam of light.

Additional features are also incorporated which protect the user against power failure, prevent outsiders from tampering with the equipment, and allow other equipment to be added, such as an external alarm system.

CONTROL BOX

Where complete protection is required and large areas are to be covered, there are systems which incorporate a special control box. To the control box may be connected one or several photocell systems, almost any amount of external alarm systems and other indicators; and, also, the closed-circuit type of burglar alarm protection.

You have probably seen many store windows with strips of tin-foil applied all around the glass and about 6 inches from the edge. This is part of a "closed-circuit system." The tin-foil strips are connected in series, and included in the circuit are switches on the doors, windows, etc., which open up when the doors or windows are opened. The circuit is then wired in series with a battery source and a high-resistance relay, and actuates an alarm when the circuit is broken. A high-resistance, sensitive relay drains very little current, and battery life is quite high.

INSTALLATION

Actual installation is much simpler than you would imagine. The only consideration required is that the beam of light should protect entrances to the building.

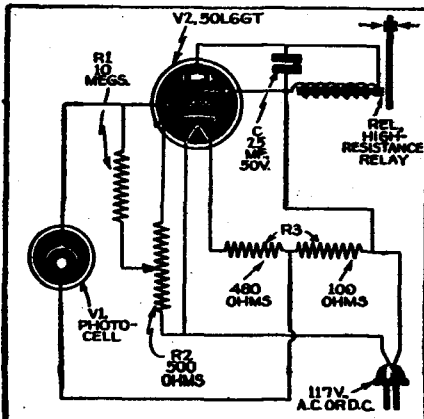

Schematic diagram of photocell-operated vacuum-tube relay. This is a simple A.C.-D.C. circuit which may be used for experimenting.

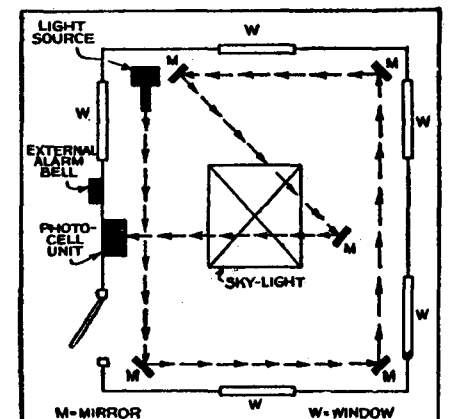

Plan of a photoelectric installation, requiring a number of mirrors but only one light source (exciter) and photocell unit, in a burglar alarm system.

BLOCK LAY-OUT OF TELEVISION SYSTEM

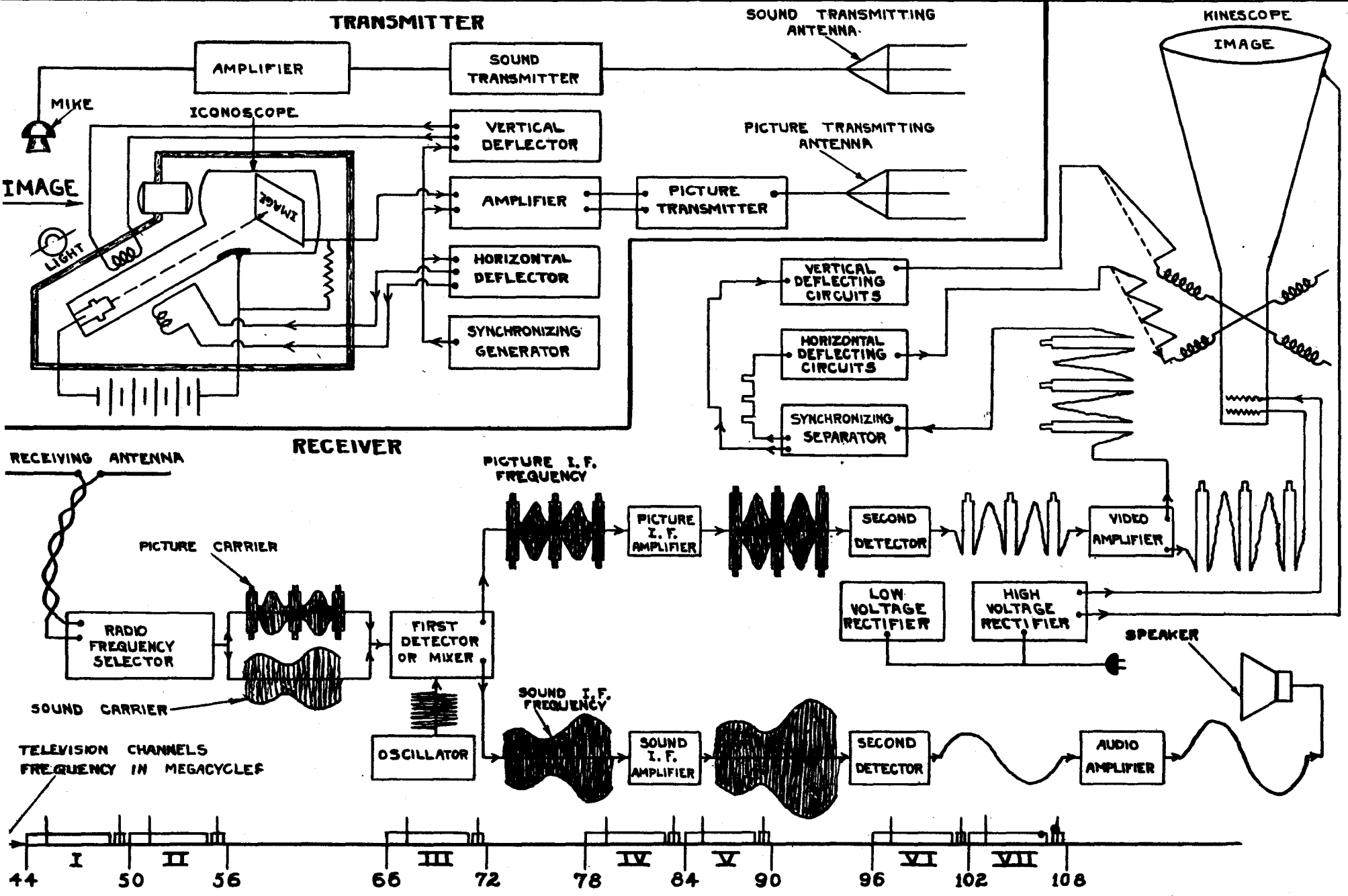

Television Definitions

Television - The transmission of moving images either by wire or radio

Field of View - The total area that is in view of the television camera at the transmitter.

Scanning at the Transmitter - The process of breaking up the field of view into thousands of small sections or elements in a systematic order, permitting analysis of the light values of each element. Scanning is accomplished in the same way that a person reads a book. He reads a page of printed matter by reading from left to right one word at a time starting with the top line and progressing down one line at a time until the bottom line is read. Television cameras read much faster. They scan the field of view several times per second.

Picture Signal - The electrical impulses corresponding to the light values of the picture elements obtained when scanning the field of view.

Scanning at the Receiver - The process by which the observer receives visual information on the screen from one element at a time in the same systematic order used to break up the field of view at the transmitter. This is similar to a person typing on paper. The typewriter records one letter or one element at a time in a systematic order.

Scanning Line - A single continuous narrow strip which is determined by the process of scanning.

Line Frequency - The number of scanning lines produced per second.

Frame Frequency - The number of complete pictures transmitted per second.

Interlaced or Fractional Scanning - A process of scanning in which the vertical sweep must be repeated to completely cover one frame.

Field Frequency - The number of times the vertical sweep is repeated per second.

Aspect Ratio = $\frac{\text{Width of field of view}}{\text{Height of field of view}}$

Negative Transmission - A type of modulation in which a dark element causes an increase in the amplitude of the carrier wave.

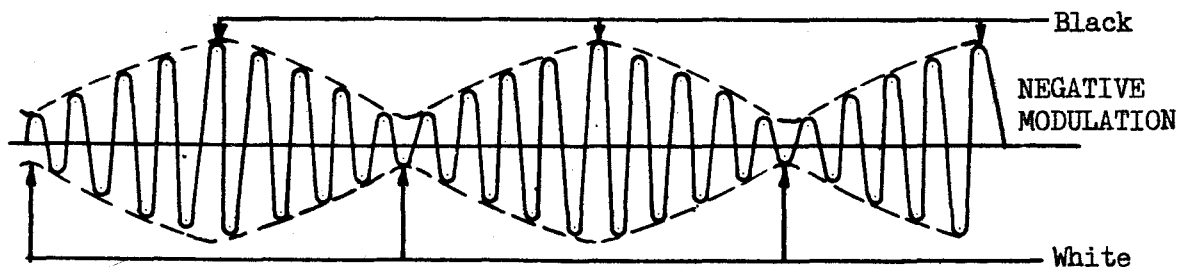

Positive Transmission - A type of modulation in which a light element causes an increase in the amplitude of the carrier wave.

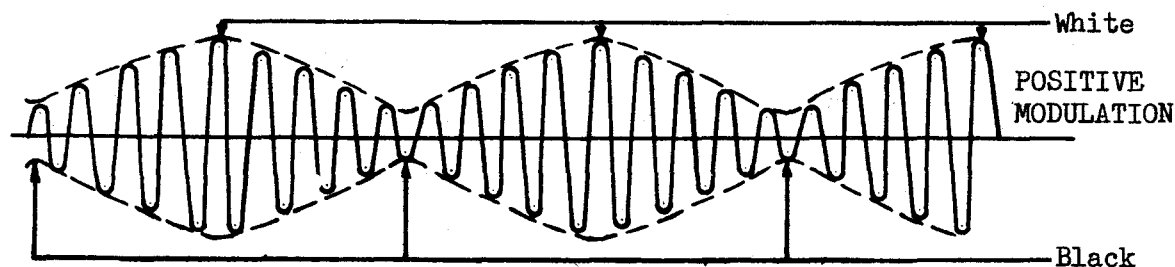

R.M.A. Television Standards - Specifications recommended by Radio Manufacturers Association, which is the present accepted standard for the United States: (A) 441 line picture (B) 30 frames per second (C) 60 fields per second (D) aspect ratio - 4/3 (E) negative transmission.

Synchronization - That function of the television system by which the transmitting and receiving ends of the system are held together in proper time relationship.

Horizontal Blanking Pulse - A pulse produced at the end of each line for the purpose of blanking out the horizontal retrace of the electron beam.

Vertical Blanking Pulse - A pulse produced at the end of each field for the purpose of blanking out the vertical retrace of the electron beam.

Horizontal Synchronizing Pulse - A pulse produced at the end of each line for the purpose of starting each scanning line at the receiver.

Vertical Synchronizing Pulse - A pulse produced during part of the vertical blanking pulse for the purpose of maintaining horizontal synchronization during this period.

Video Signal - Pertaining to all voltages resulting from television scanning.

Side-Bands - One on either side of the carrier frequency produced by the process of modulation.

R.M.A. Standard Television Signal - Modulates the carrier wave.

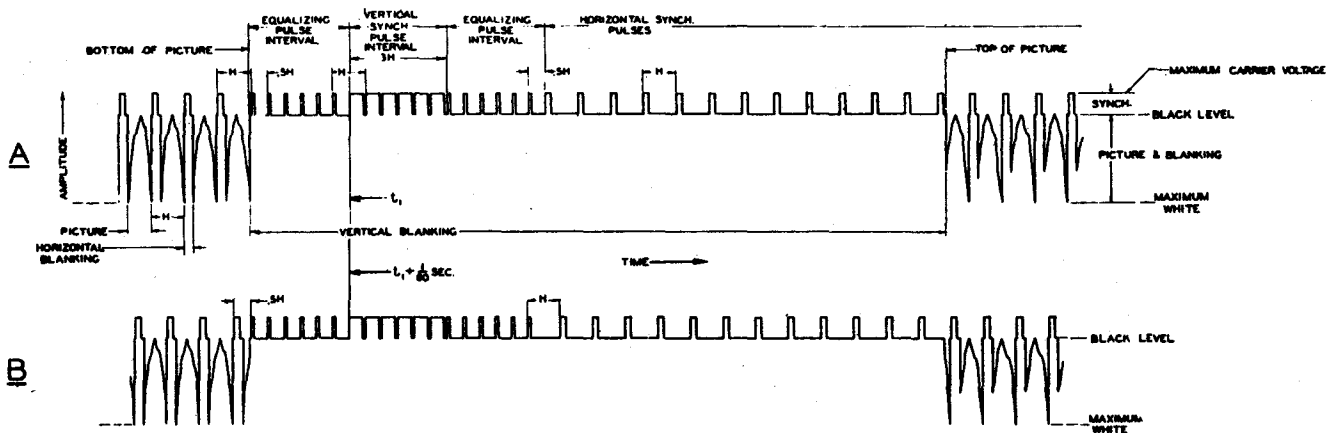

Vestigial Side-Band Transmitter - One in which one side-band and a portion of the other are intentionally transmitted.

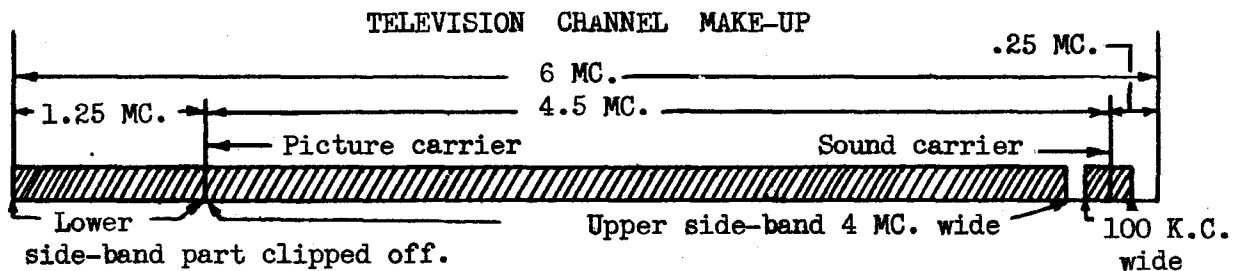

ICONOSCOPE-CAMERA TUBE (R.C.A.)

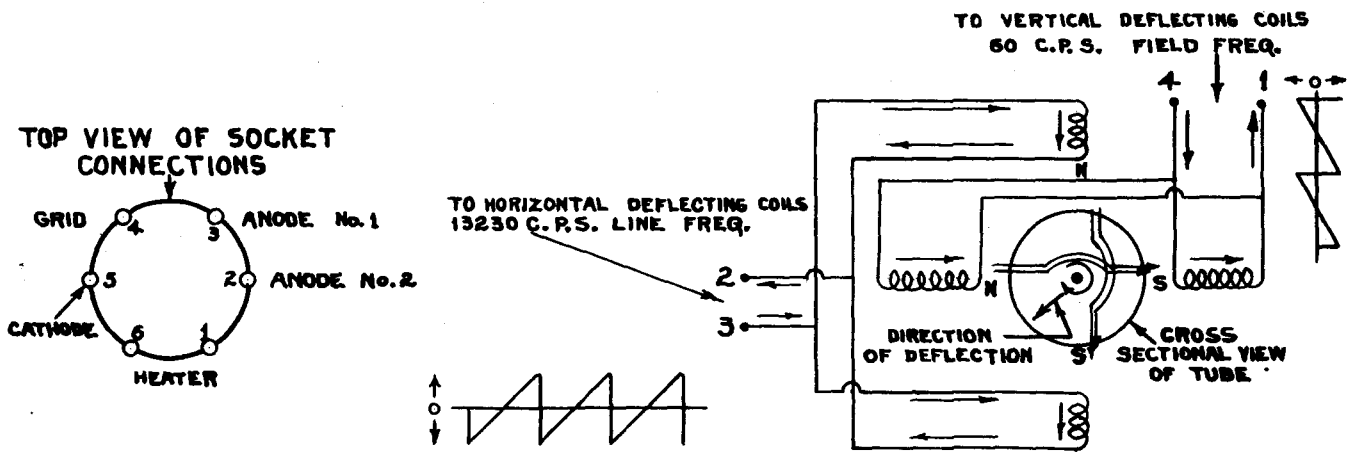
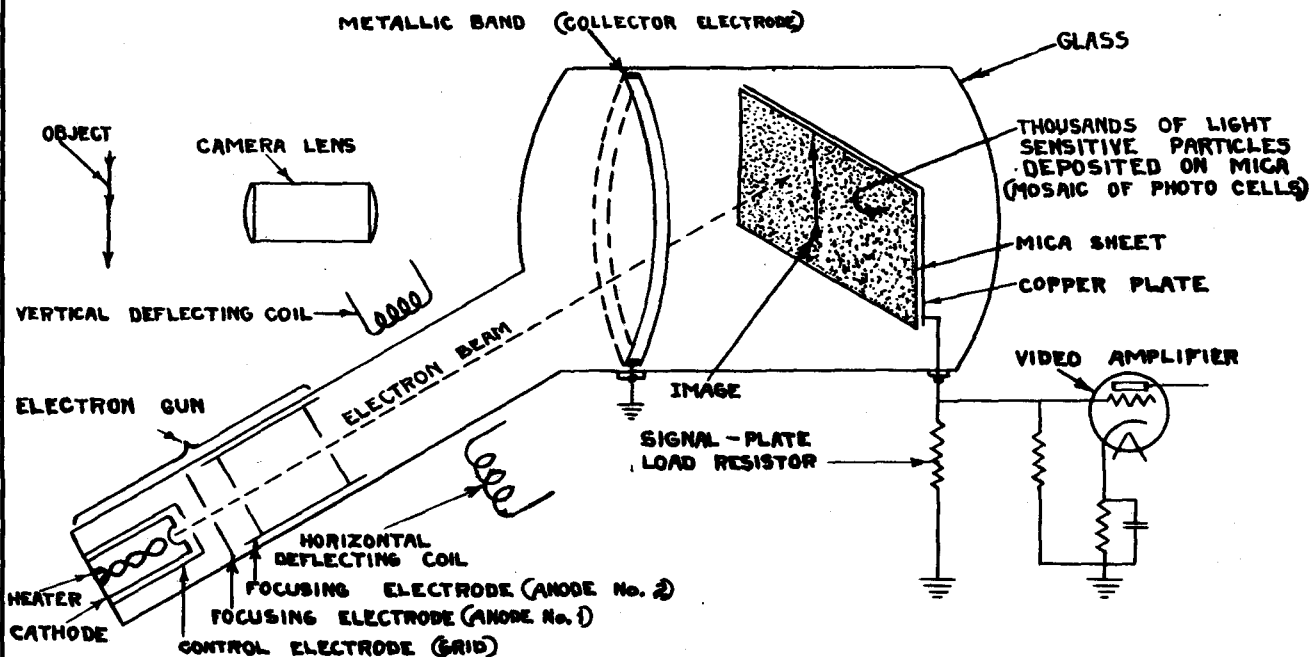

REGULATED HIGH-VOLTAGE SUPPLY FOR ICONOSCOPE

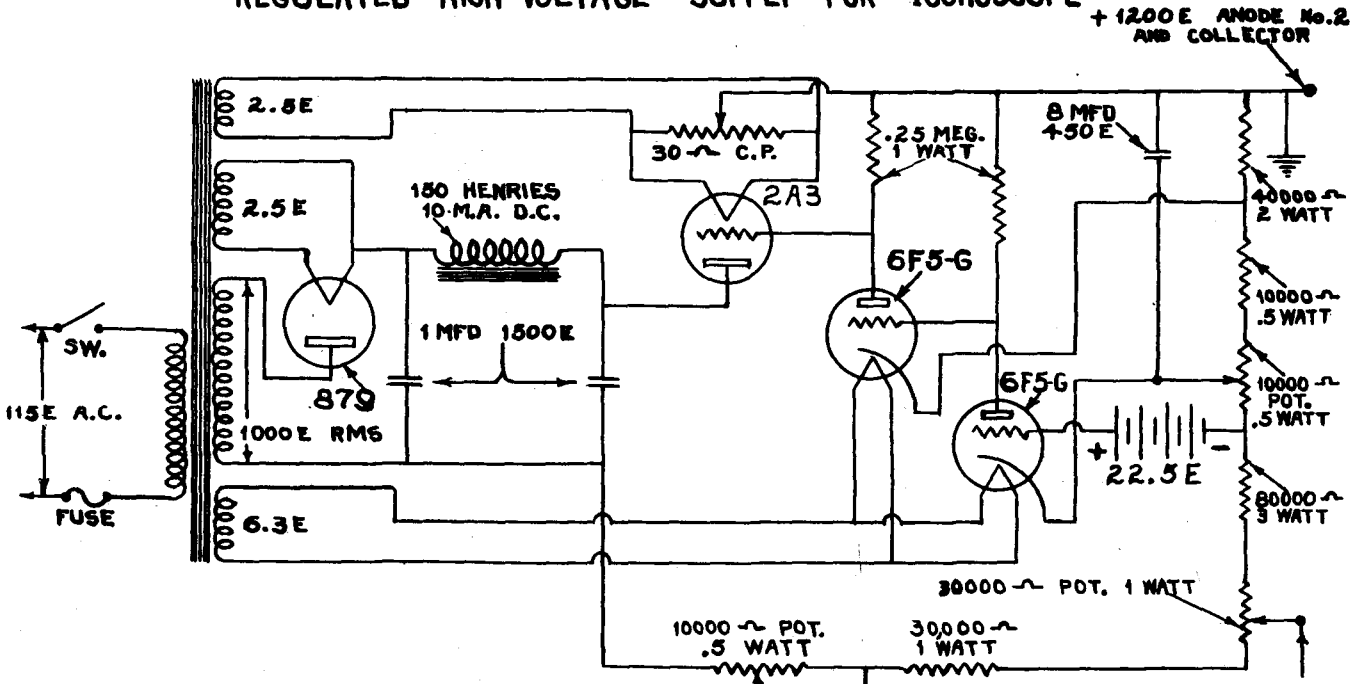

KEYSTONING CIRCUIT

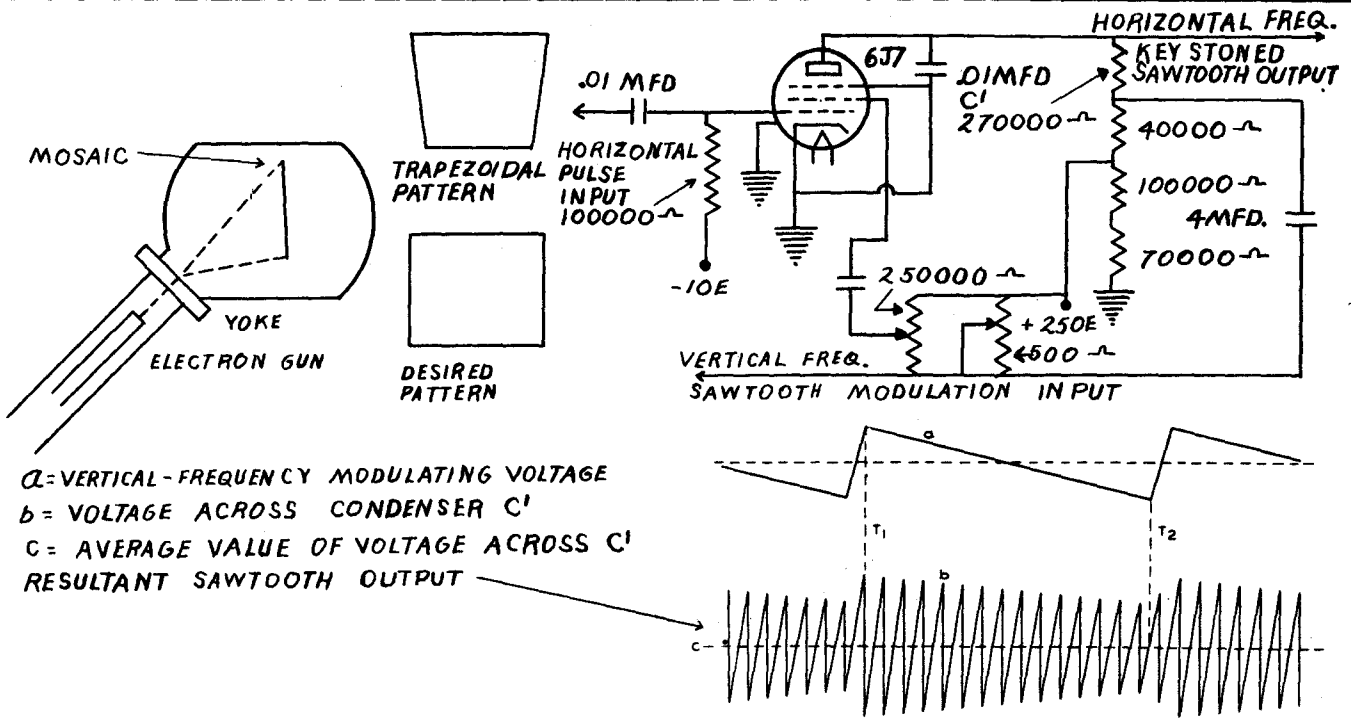

OUTPUT STAGE FOR VERTICAL DEFLECTING CIRCUIT

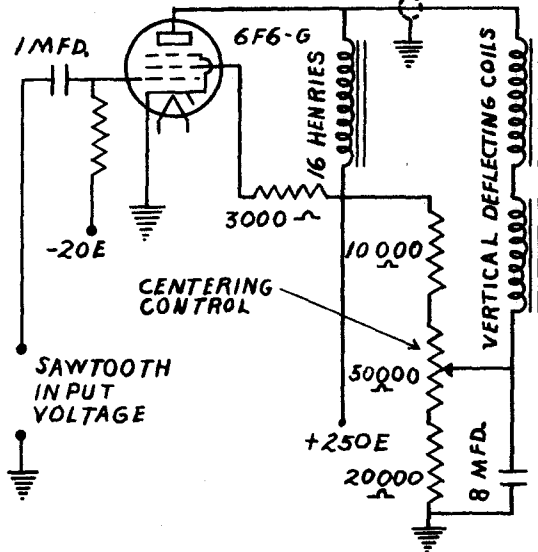

OUTPUT STAGE FOR HORIZONTAL DEFLECTING CIRCUIT

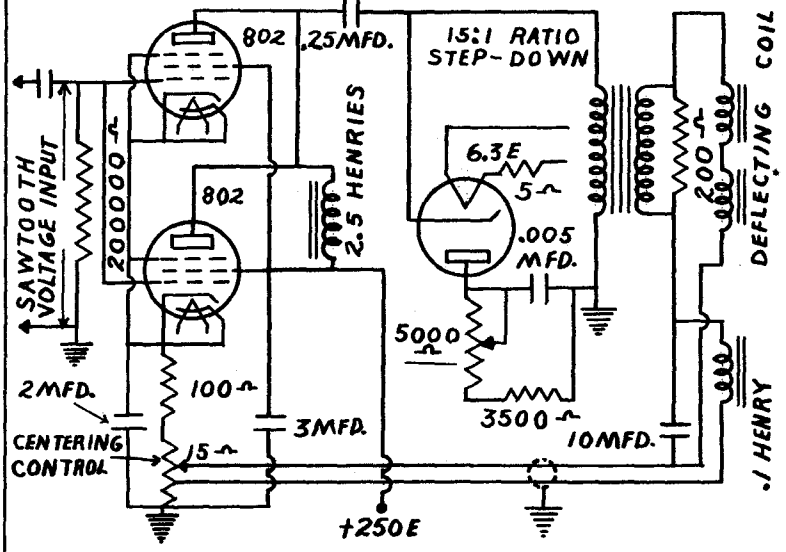

ICONOSCOPE DEFLECTING YOKE

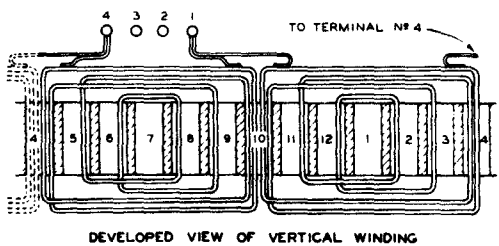

265 TURNS
#36 S.S.E.
WIRE PER COIL

ICONOSCOPE DEFLECTING YOKE CORE

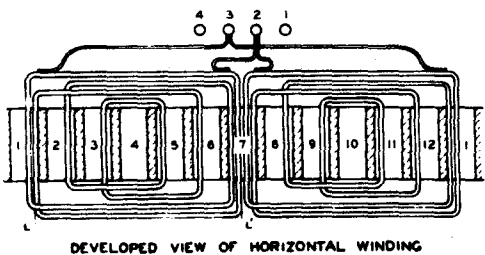
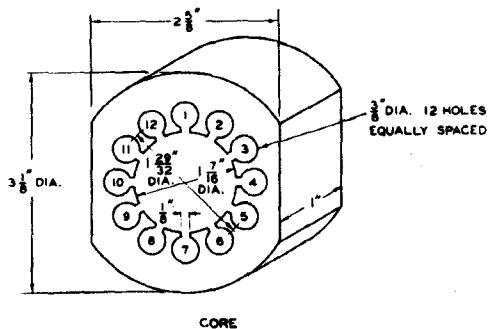

14 TURNS
#26 S.S.E.
WIRE PER COIL

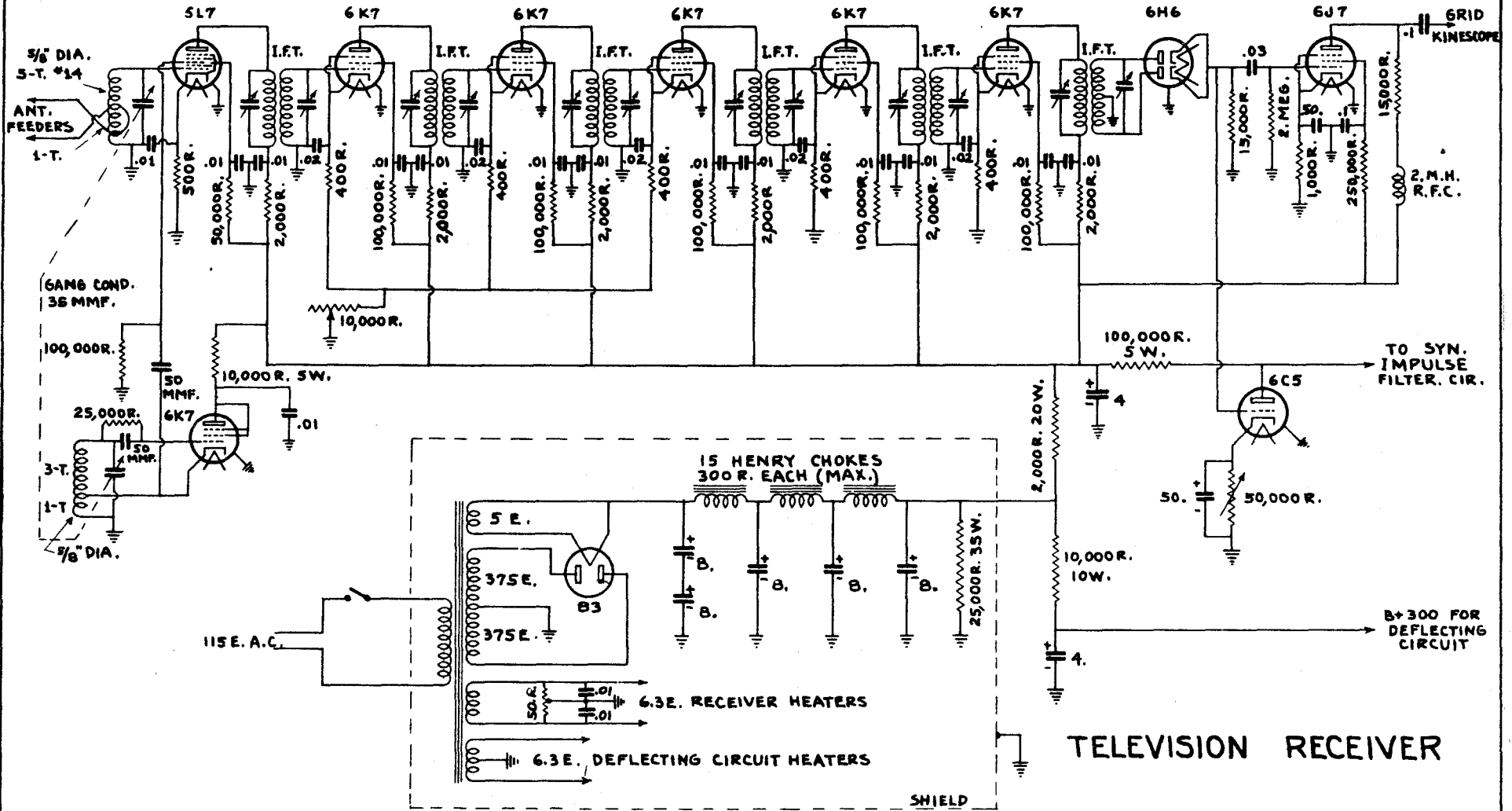

TELEVISION RECEIVER

FREQUENCY ALLOCATIONS PERMITTING SOUND AND PICTURE TRANSMISSION ON A SINGLE CHANNEL.

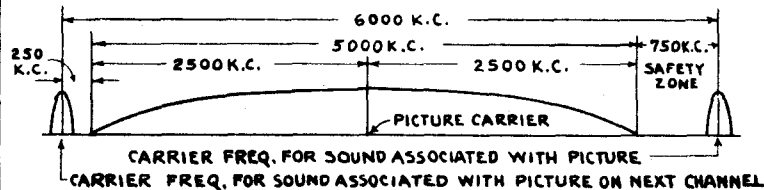

BLOCK DIAGRAM OF RECEIVER EQUIPMENT REQUIRED FOR RECEPTION OF SOUND AND PICTURE.

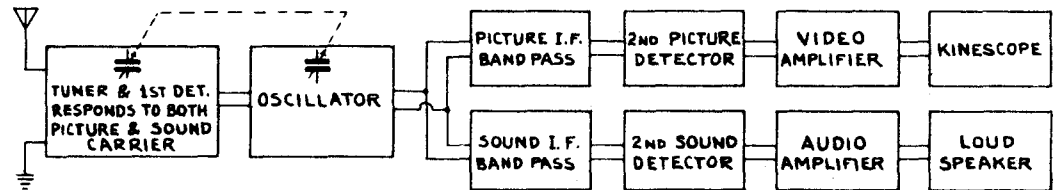

CATHODE RAY TUBE (KINESCOPE) USED WITH TELEVISION RECEIVER FOR IMAGE REPRODUCTION.

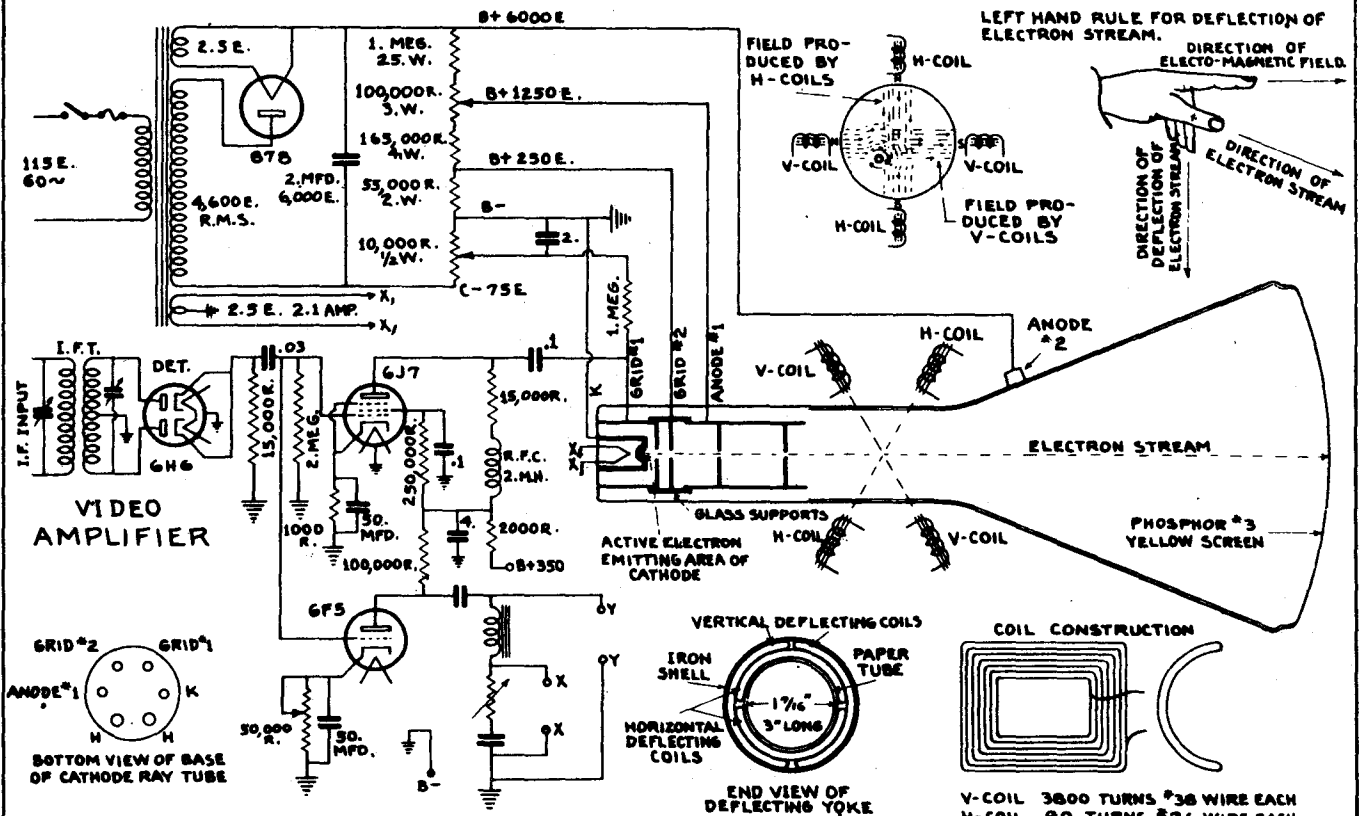

VERTICAL-DEFLECTING CIRCUIT

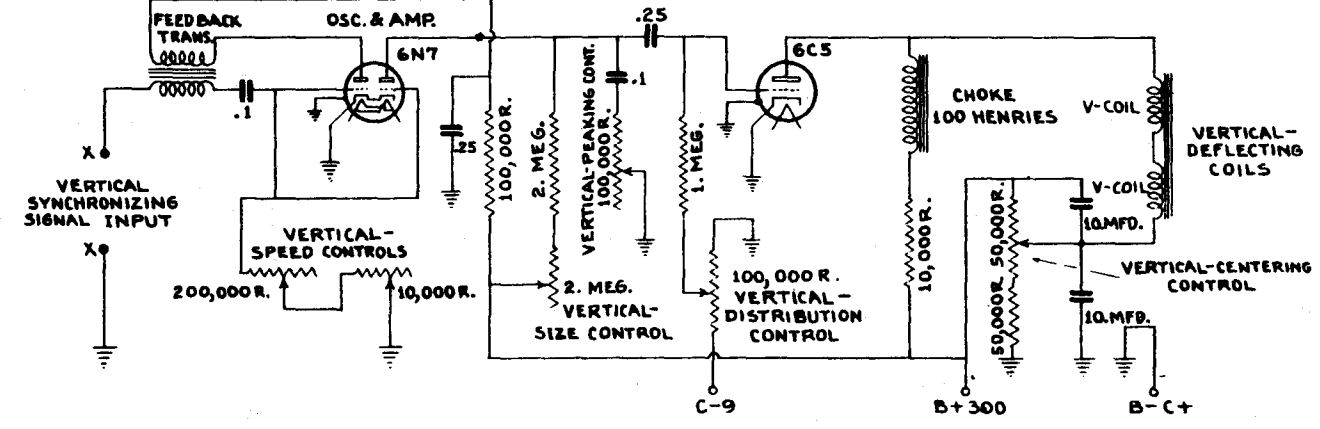

HORIZONTAL-DEFLECTING CIRCUIT

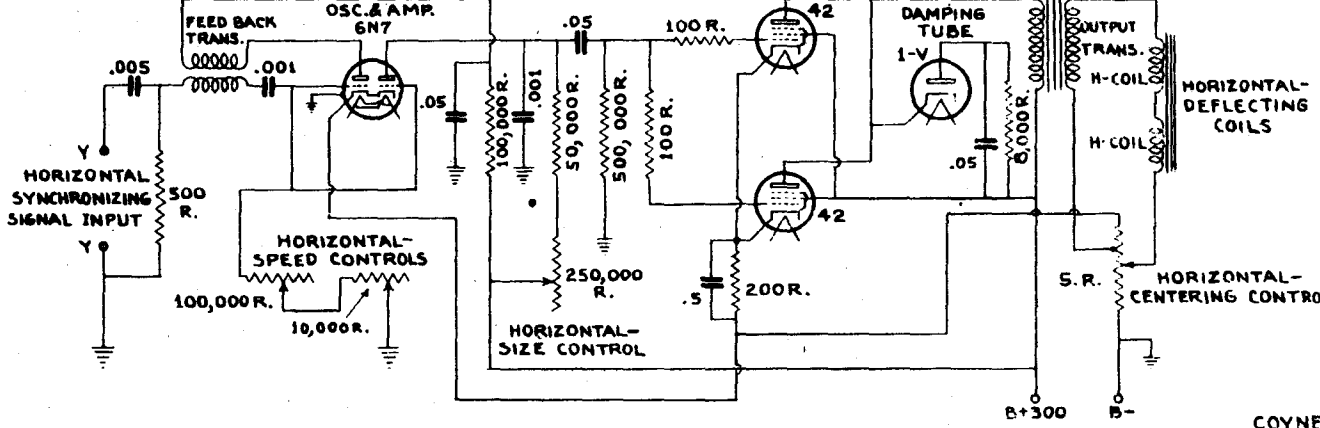

MECHANICAL SYSTEM OF TELEVISION TRANSMISSION & RECEPTION.

LENSES

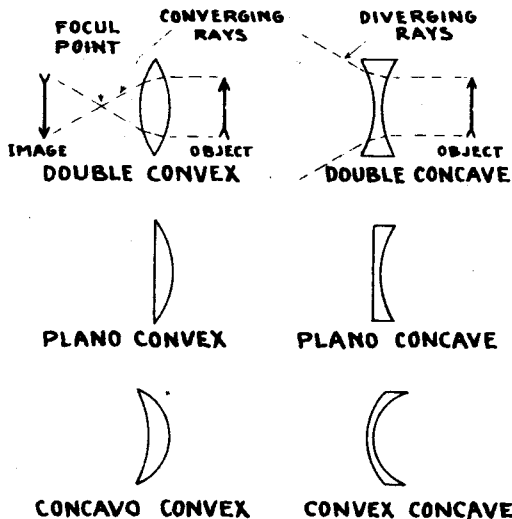

ACTION OF LIGHT WHEN STRIKING ORDINARY MIRROR.

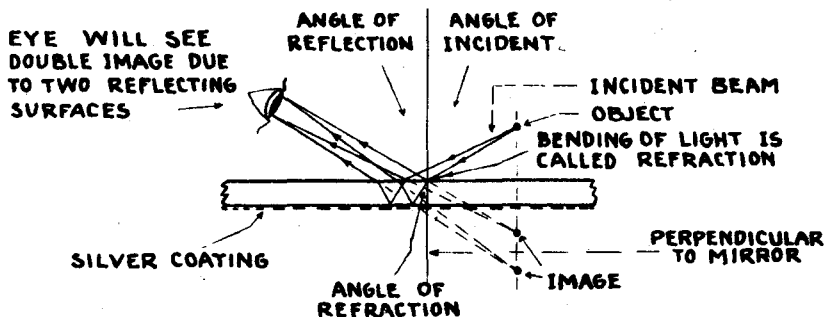

MIRRORS.

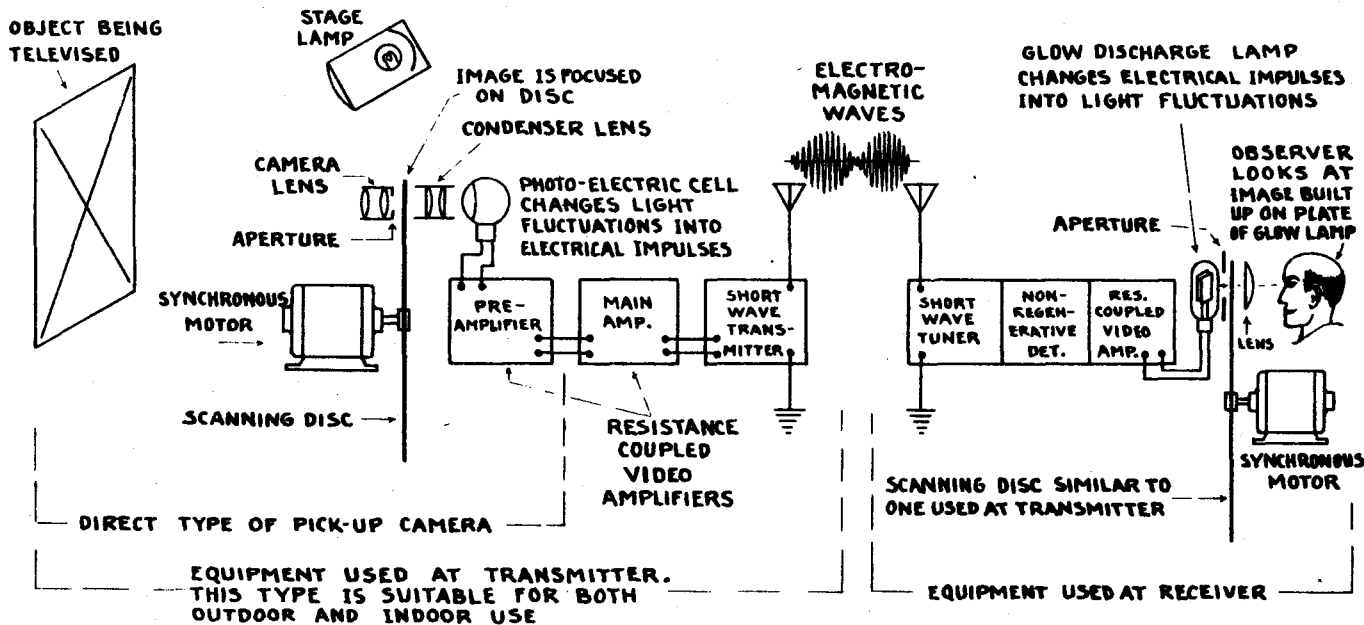
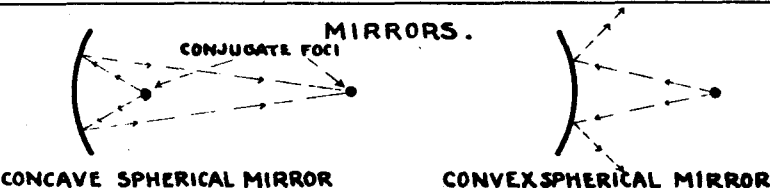

FLYING SPOT OR INDIRECT TYPE OF PICK-UP CAMERA, FOR INDOOR USE ONLY

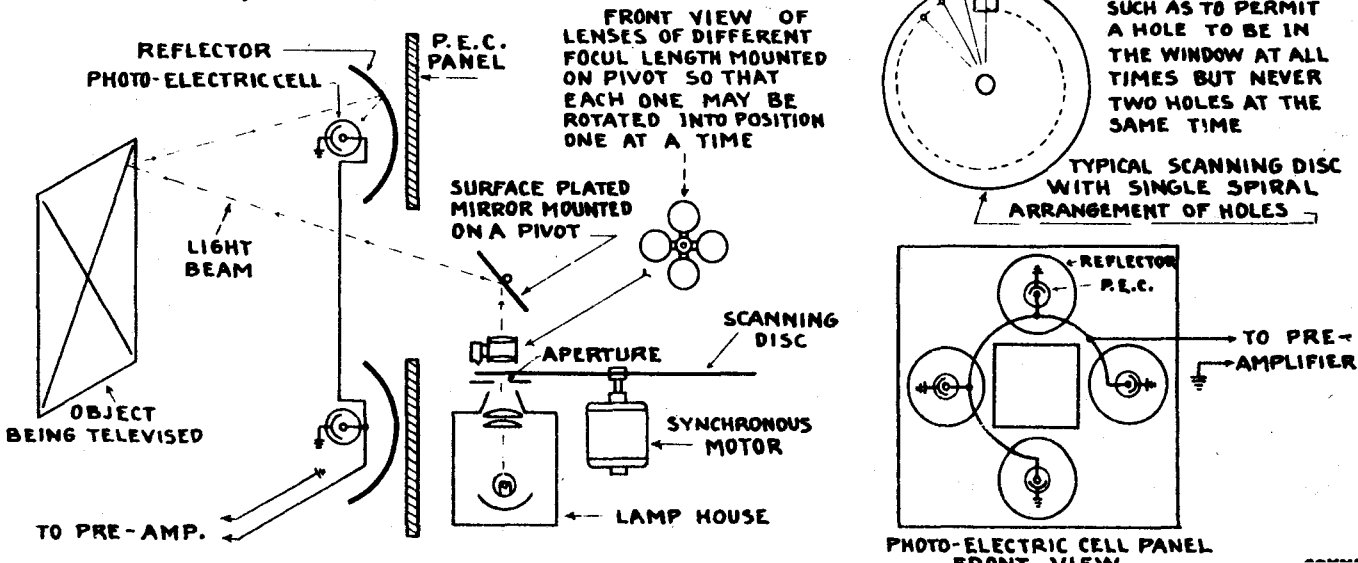

FIG. 1

GLOW DISCHARGE LAMPS

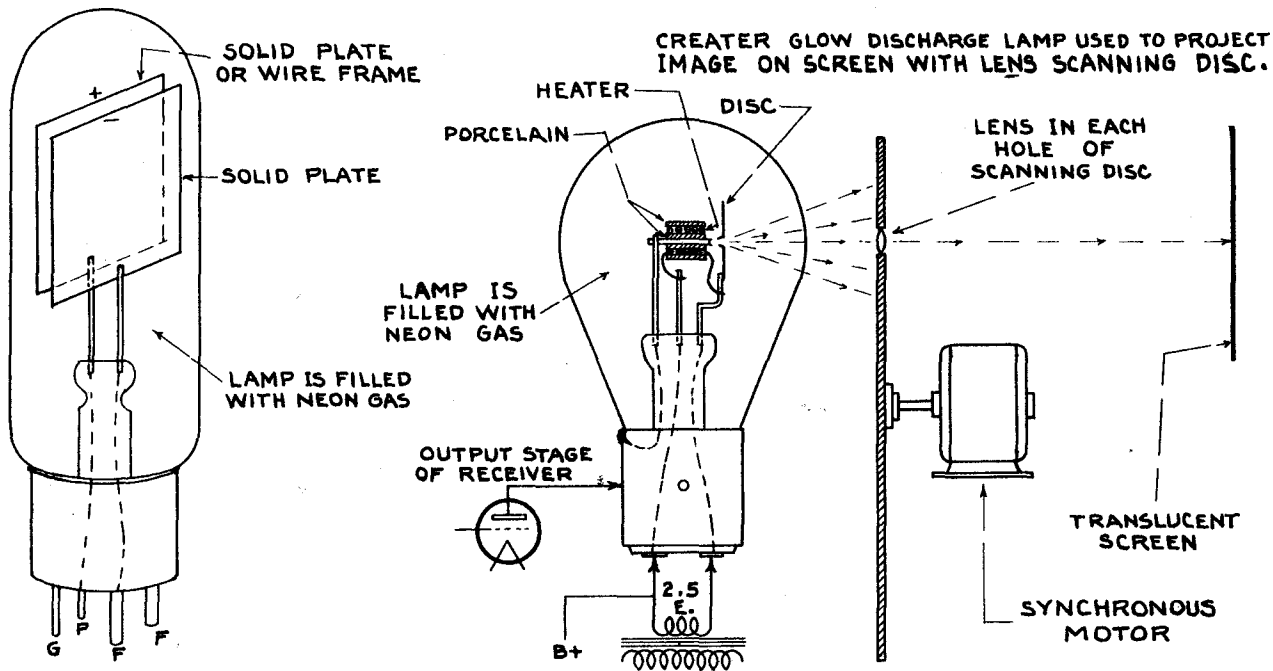

FIG. 2

PECKS' SYSTEM OF PROJECTING IMAGE ON SCREEN USING MIRROR-LENS DRUM.

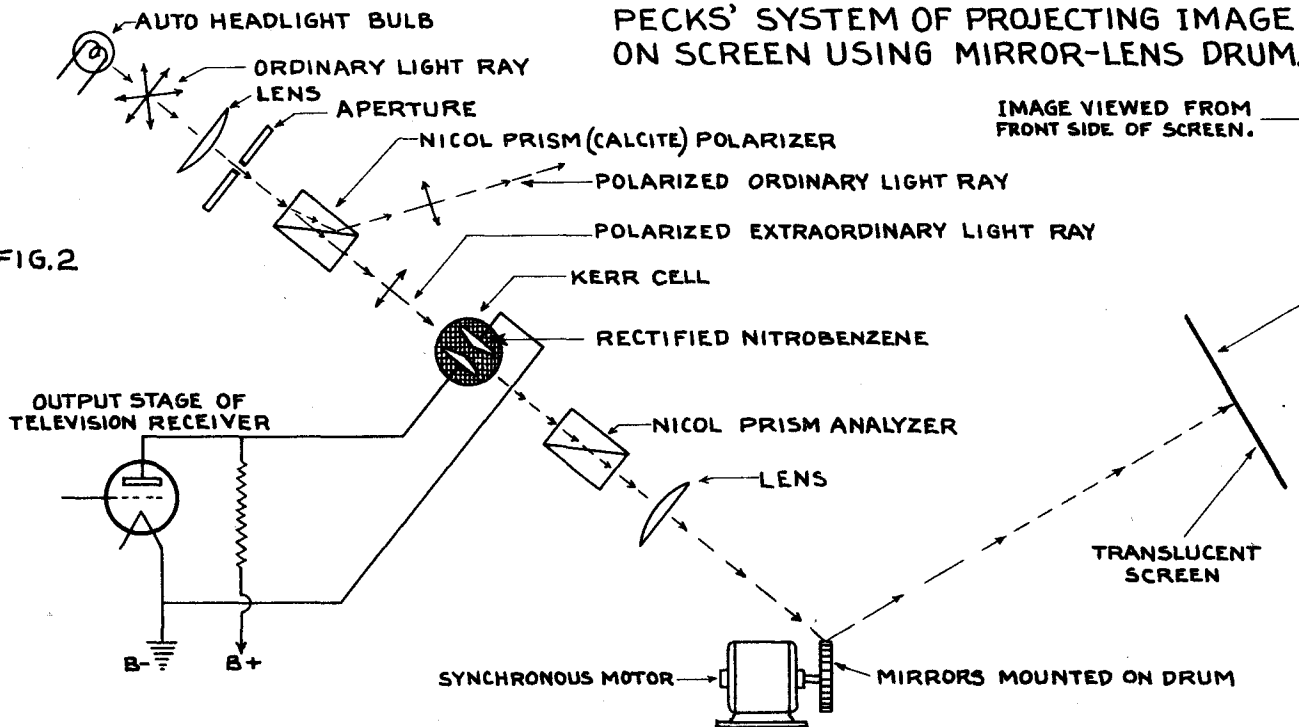
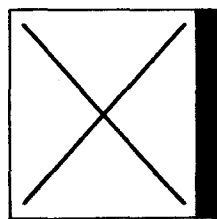
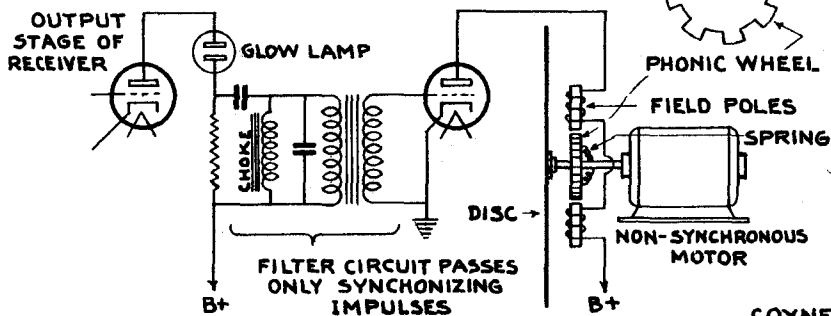

FIG. 3

PHONIC WHEEL - AUTOMATICALLY KEEPS THE TRANSMITTER AND RECEIVER DISCS IN SYNCHRONISM WITH EACH OTHER BY ACTING AS AN ELECTRICAL ACCELERATOR OR BRAKE AS REQUIRED.



SYNCHRONIZING IMPULSES ARE PRODUCED BY PLACING THIS BAND OF CONTRASTING SHADE ON ONE SIDE OF FIELD OF VIEW AT TRANSMITTER.



TRANSMITTER CIRCUITS.

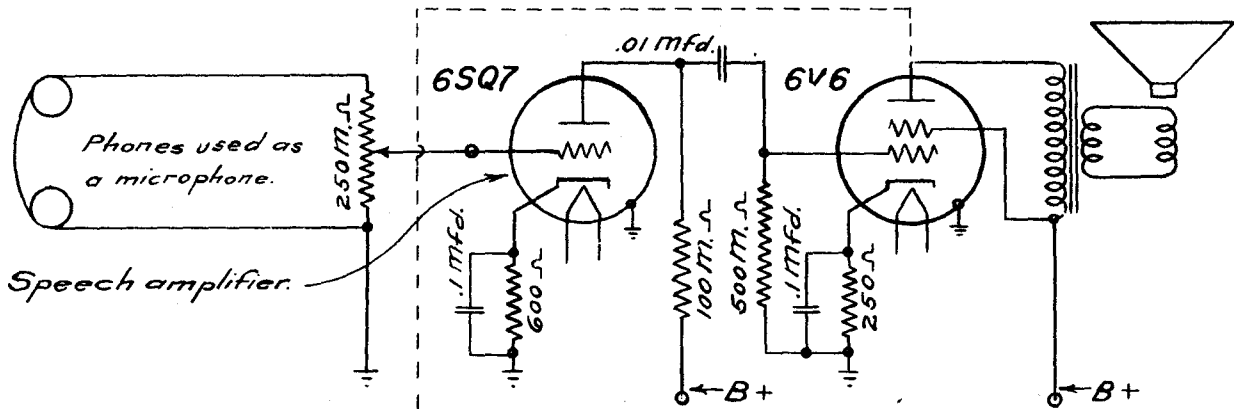

TWO STAGE AUDIO AMPLIFIER.

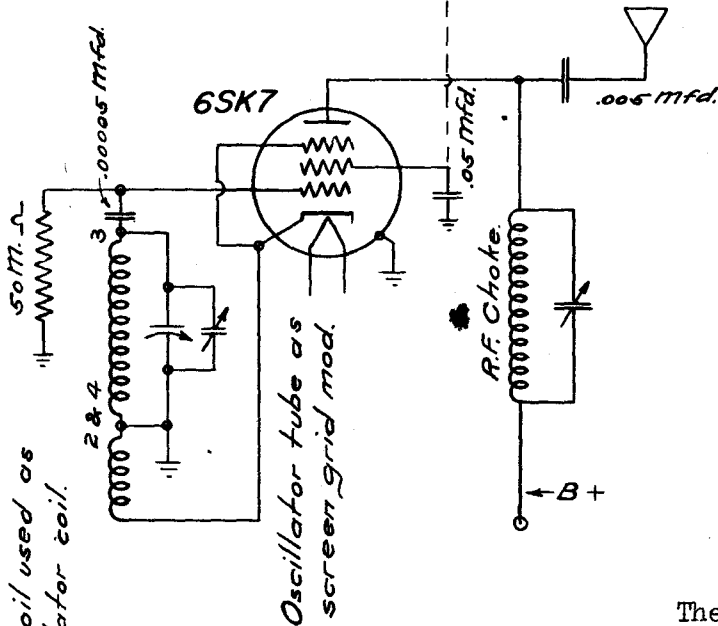

OSCILLATOR.

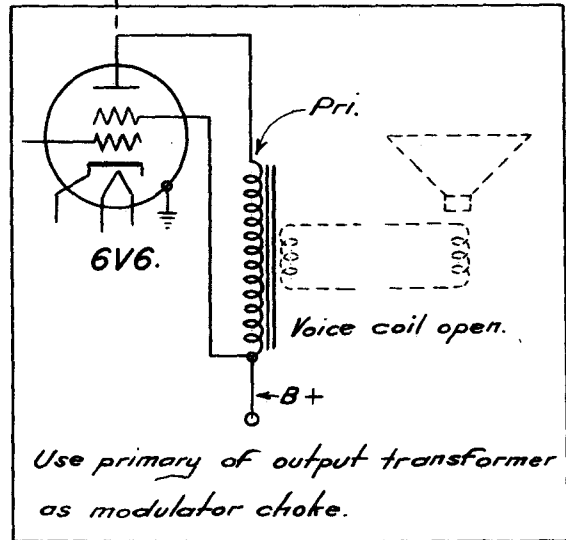

Use primary of output transformer as modulator choke.

The two stage amplifier shown above may be connected as indicated by the dotted line and used to modulate the RF energy produced by the oscillator.

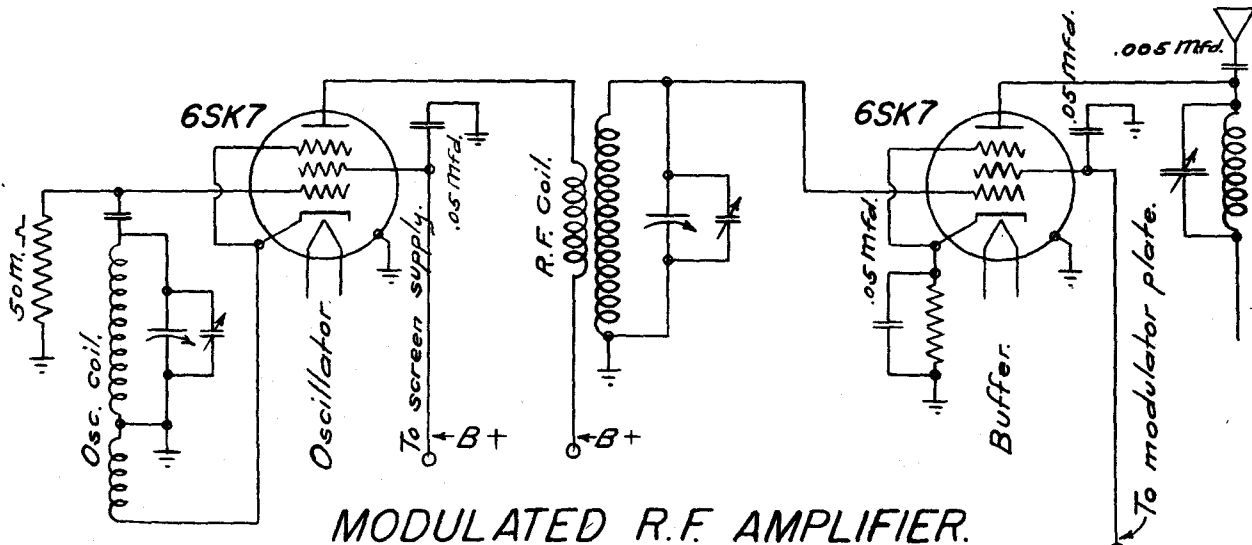

MODULATED R.F. AMPLIFIER.



Sound Wave (Audio Frequency): Frequencies range from 16 to 15,000 cycles depending on the pitch of the note. Value depends on the loudness of the sound.

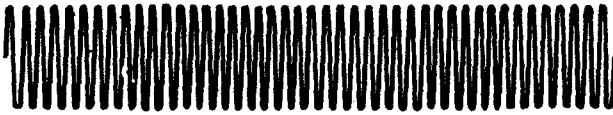

Radio Frequency Carrier Wave: Frequencies range from 550 k.c. to 1700 k.c. in the broadcast band. Frequencies above are employed in the Short Wave Band.

Amplitude Modulation

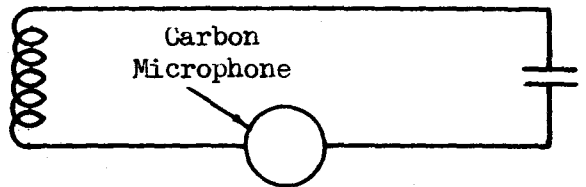
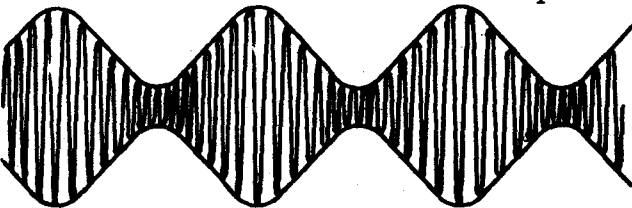

An Amplitude Modulated (A.M.) carrier has its frequency held constant at a specified value and its amplitude is changed in accordance with the audio frequencies impressed on it.

Frequency Modulation

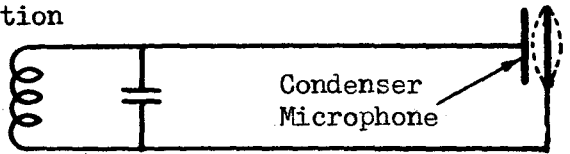
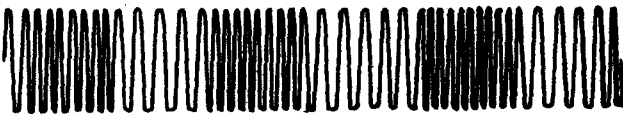

A Frequency Modulated (F.M.) carrier has its frequency varied in accordance with the audio frequencies impressed on it and the amplitude of the carrier is held constant.

Oscillator

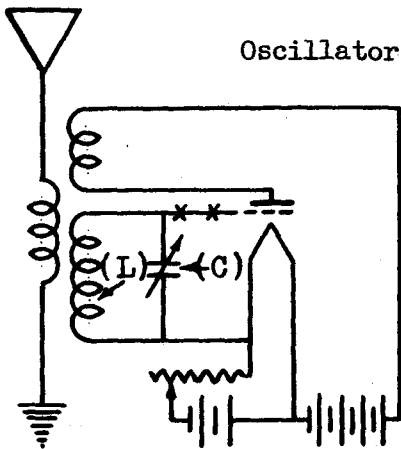

E.G. - I.P. Characteristic curve

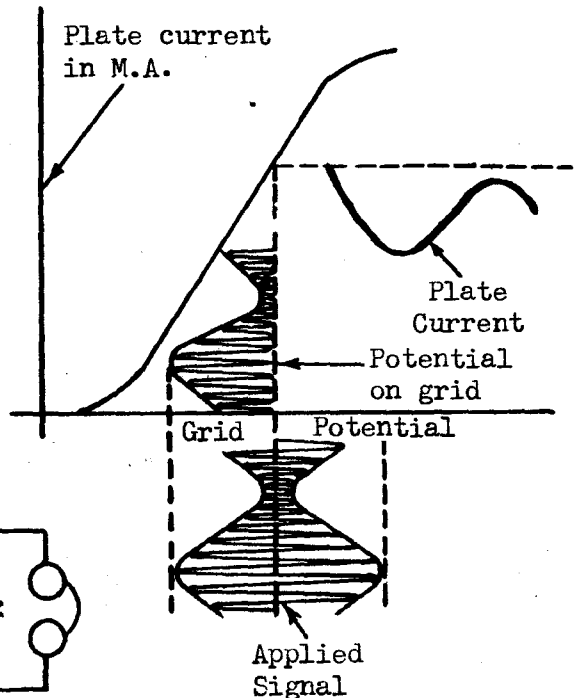

Detector

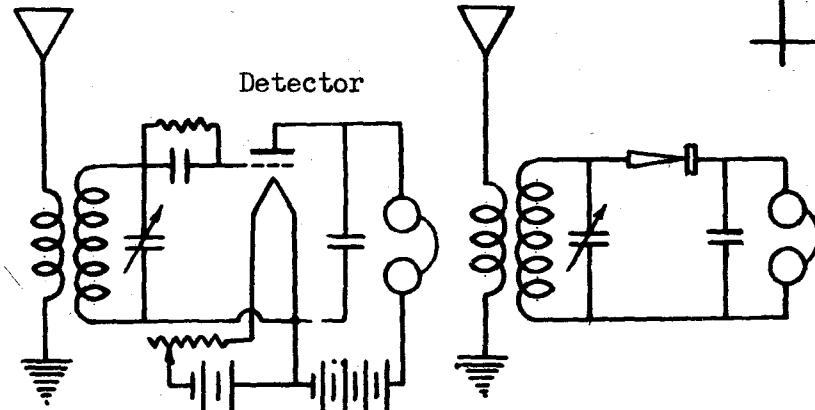

3-D MIXER PANEL

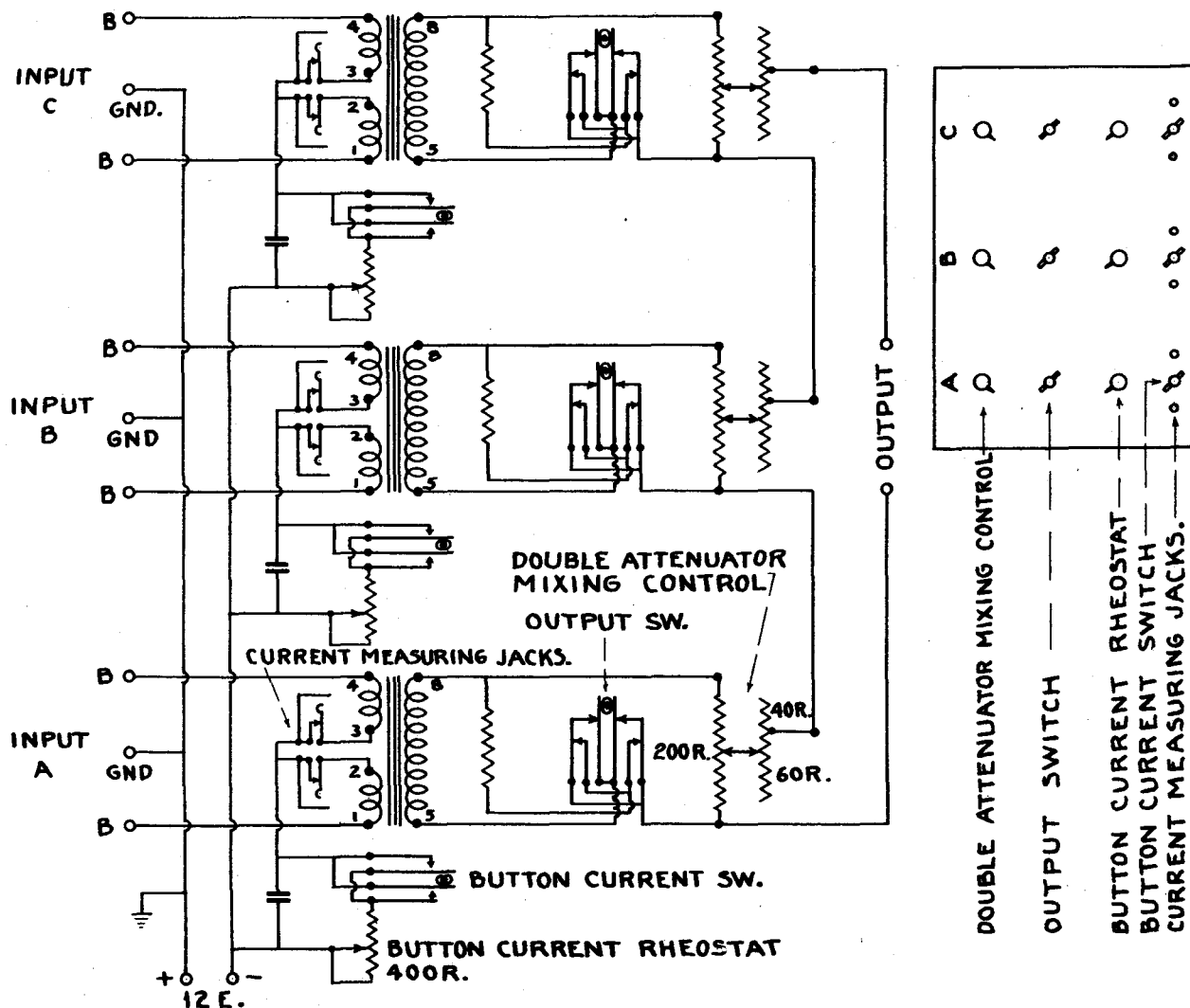

Installation and Operation.

Connect the output terminals of the mixing panel to the 200 ohm input terminals of the amplifier. Connect battery supply only when carbon microphones are to be used. The input terminals for the three mixing channels are designated as A, B, and C.

When carbon microphones are used, connect the button terminals of the microphone to the two outer terminals of the mixer marked B and the frame of the microphone to the center terminal marked GROUND.

When condenser type transmitters are used, connect the output of the condenser transmitter to the two outer terminals marked B.

In the case of carbon microphones, an individual button current switch is associated with each channel and current measuring jacks are provided for obtaining the proper microphone current. This current should be adjusted to approximately 20 milliamperes in each button circuit by means of the rheostat marked INCREASE. The output switch can now be turned on and the level adjusted as desired by means of the mixing control.

When condenser transmitters are used, the button current switch should be left in the OFF position at all times.

TYPE "C" MONITOR PANEL

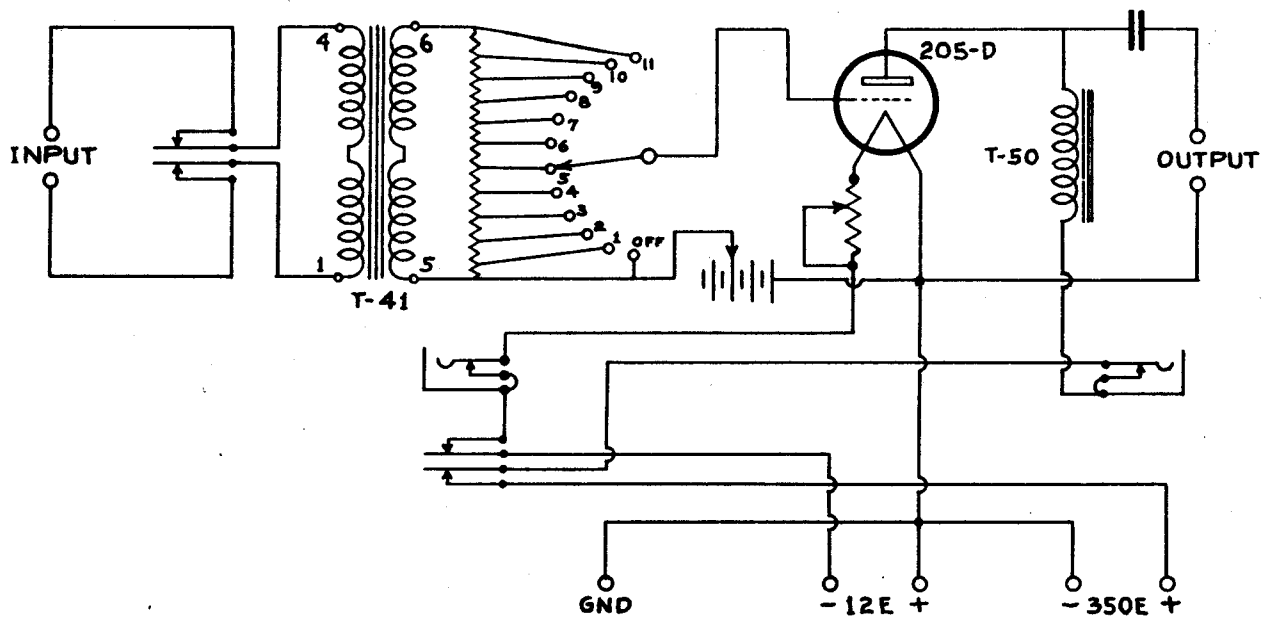

OPERATION

Connect the high impedance monitoring speaker to the output terminals. Turn on the battery switch and adjust the filament current to 1.6 amperes and by means of the C-bias adjust the plate current to a value between 20 M.A. and 25 M.A.

VOLUME INDICATOR PANEL

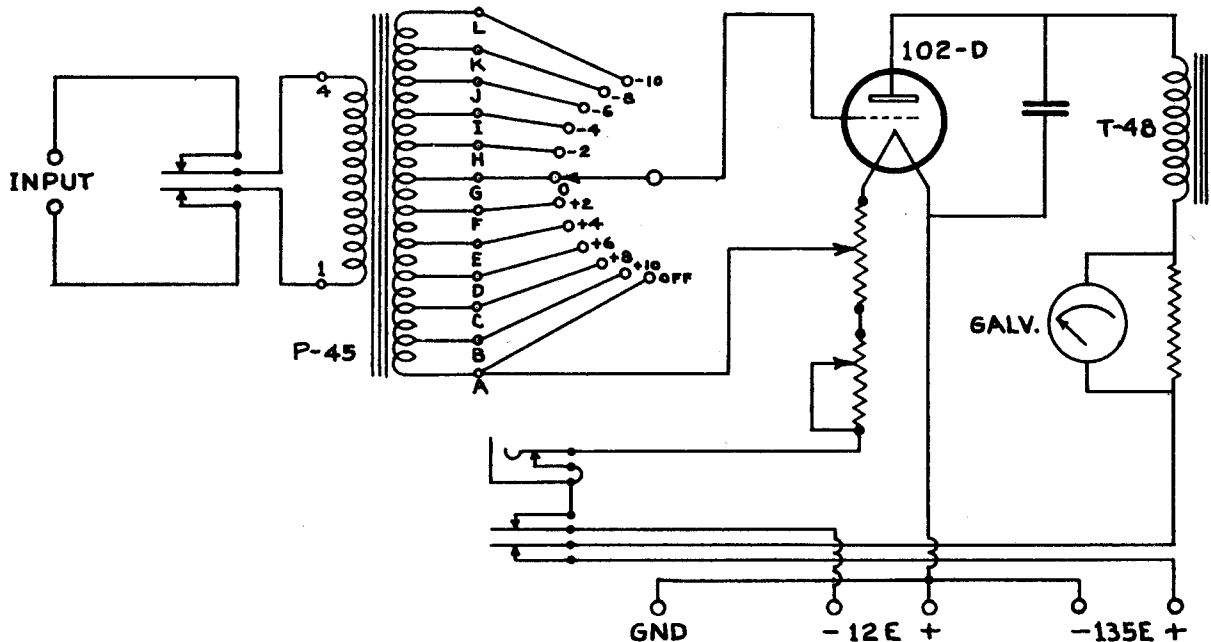

OPERATION

After turning battery switch to the ON position, adjust the filament current to .98 amp. The meter reading is now adjusted to the first red line by means of the C-bias control. After these adjustments have been made, the volume indicator is now ready for operation. After turning on the input switch, adjust the volume indicator switch, until the peak of the program level just causes the meter to read one scale division past center.

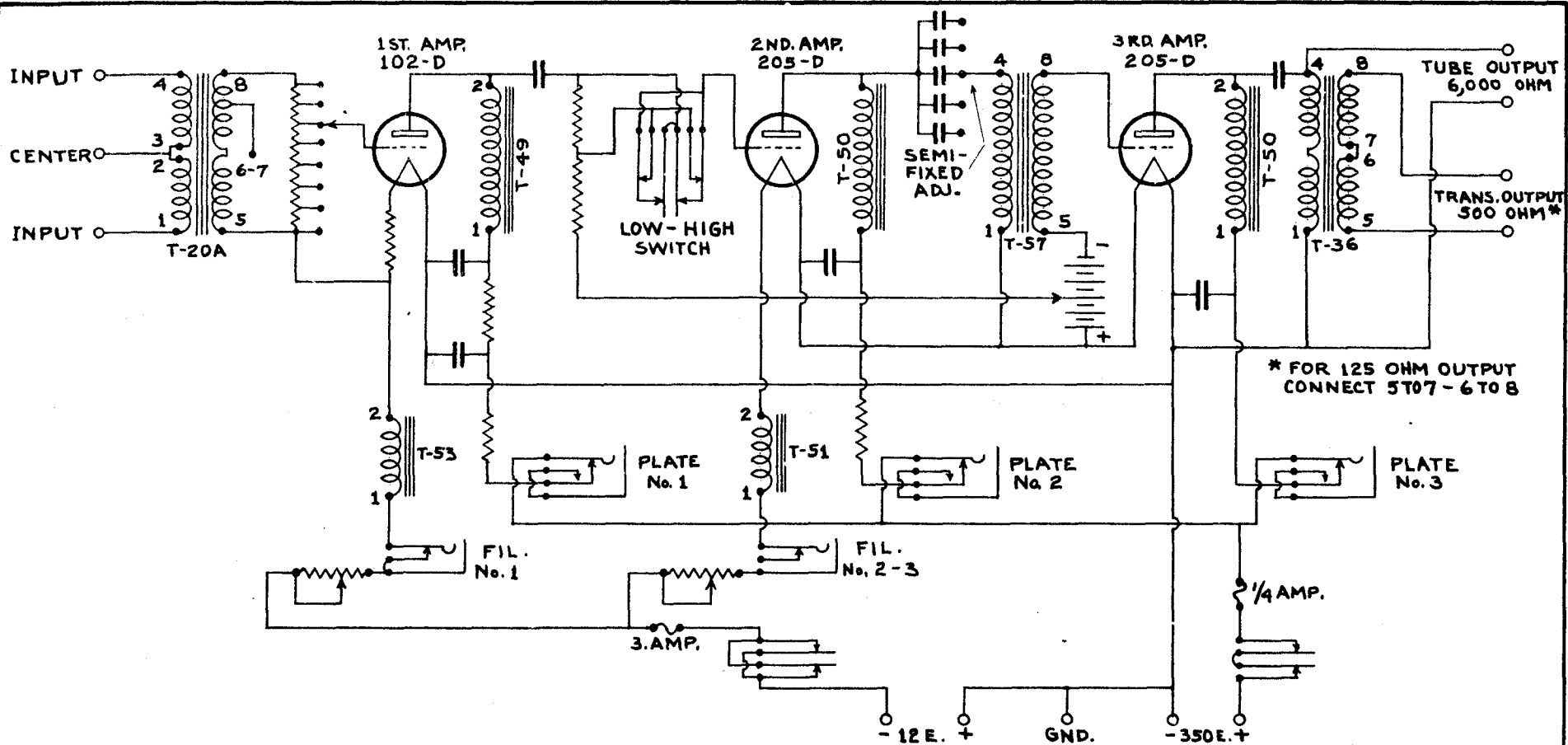

INSTALLATION AND OPERATION OF TYPE "C" AMPLIFIER

This class "A" amplifier will amplify audio frequencies from about 50 to 6000 cycles. It should be mounted in a vertical position, preferably on a standard mounting bay. The input terminals should be connected to a 200 ohm input source and the transformer output connected to a 500 ohm load (tube output terminals are provided for a 6000 ohm load.) Close the 12 volt battery switch, adjust filament "1" (102-D) to .98 amperes and filaments "2" and "3" (two 205-D tubes in series) to 1.6 amperes. Before closing the 350 volt battery switch, be certain that the MAXIMUM bias battery is in the circuit. The 350 volt switch can now be closed. Plate current #1 should be between $\frac{1}{2}$ and $1\frac{1}{2}$ M.A. The C-bias on the second amplifier should now be adjusted to give approximately 12 M.A. The C-bias of the third amplifier should be adjusted to give between 20 and 25 M.A. The gain of the amplifier should not be increased to a point above which there is any noticeable fluctuation of current in the plate circuit of the last amplifier. During operation, this should be checked occasionally to make sure that the plate current of this tube is perfectly steady. The switch marked HIGH and LOW introduces a loss of approximately 20 D.B. in the amplifier when in the low position.

POWER UNIT FOR 75 WATT TRANSMITTER.

Generator Out-put.

- 350 M.A. at 1000 V. for plate circuit.
- 15 Amps. at 14.6 V for filament circuit.
- 10 Amps. at 14.6 V. Charging spare battery.

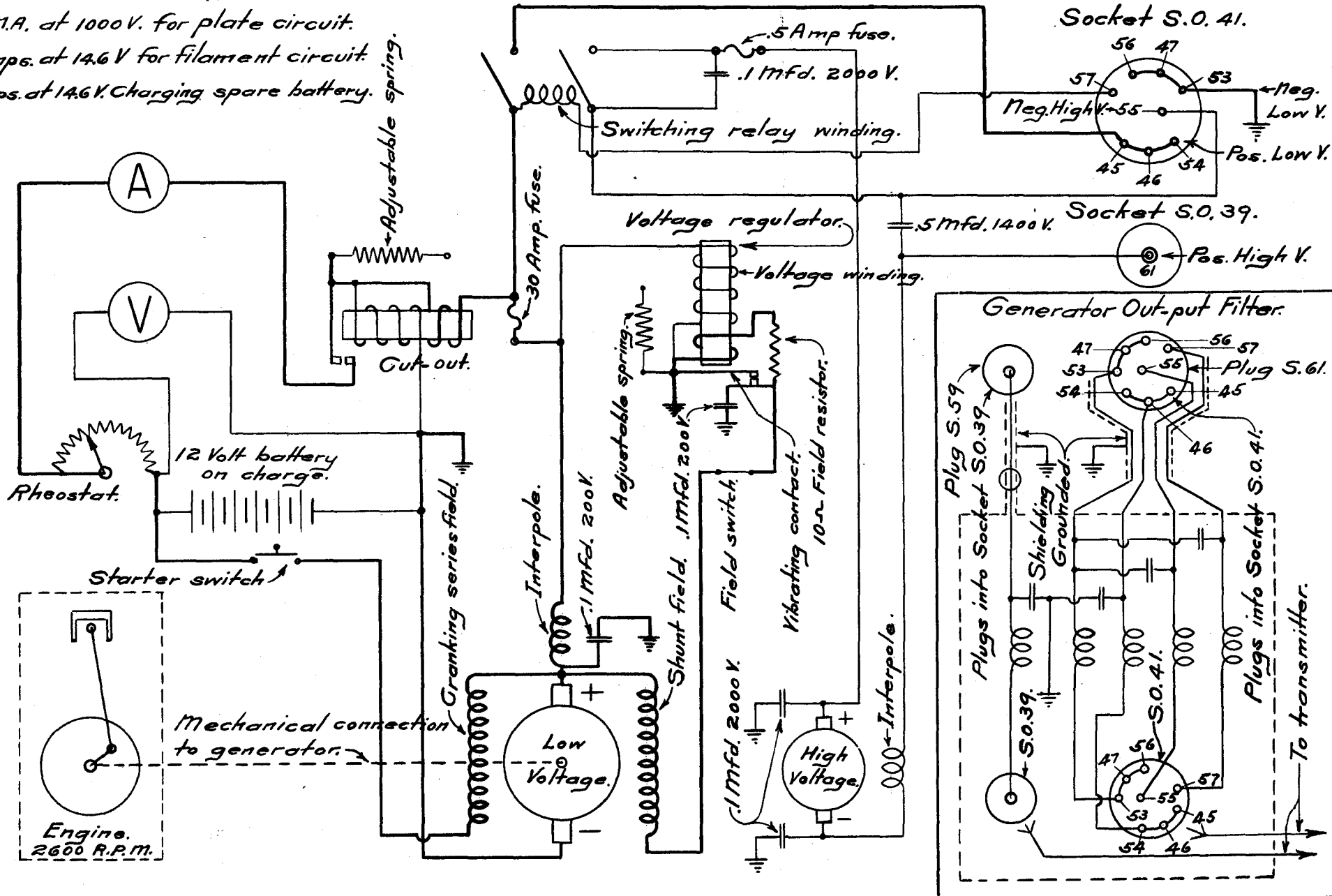

DYNAMOTORS.

VOLTAGE CHANGING

In the A.C. circuit, changing the voltage from one value to another is readily accomplished by means of a transformer. In the D.C. circuit, no such simple method of stepping up or stepping down a D.C. voltage is available. Whenever a D.C. voltage of a specified value is needed, a D.C. generator, driven by a prime mover such as is shown in Fig. A is usually employed.

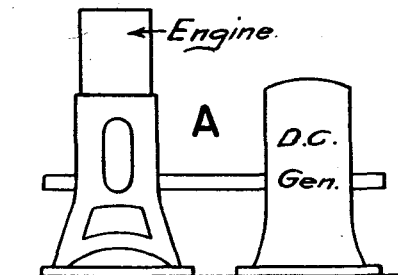

VOLTAGE STEP UP

Fig. B indicates how a D.C. voltage may be raised by the use of a motor generator set. A 110 volt motor is used to drive a 220 volt generator; in this way the voltage is stepped up from 110 to 220 volts. Note that such an arrangement does not result in any increase in power, for the power output of the generator must always be less than the power input to the motor. In small units, the overall efficiency of such a voltage conversion device may be below 50%.

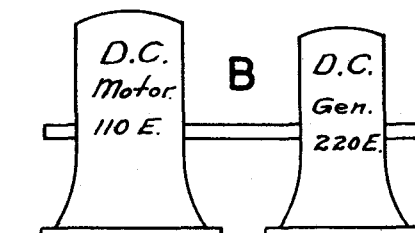

VOLTAGE STEP DOWN

Fig. C indicates a voltage step down arrangement and shows how several different voltages may be obtained. In this case, three separate generators, each having a different voltage rating, are operated from the same driving unit. The obvious disadvantage of this assembly is the space requirement and the cost.

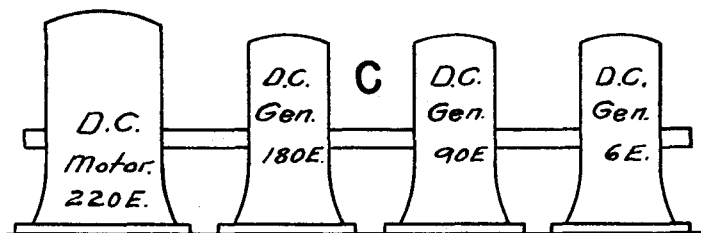

THE DYNAMOTOR

The disadvantages of cost, space requirement, and duplication of machines has been overcome in the unit shown in Fig. D. Separate machines have been replaced by separate windings and commutators. The heavy winding shown at the left receives energy from the battery and operates the unit as a motor, the other windings, moving in the same magnetic field, generate voltages that are collected from the separate commutators. Note that it is possible to have the input voltage stepped up and stepped down in the same machine; however, such a combination is unusual. It is important to observe that there is no electrical connection between the separate windings for this machine is really three separate units that use the same magnetic field.

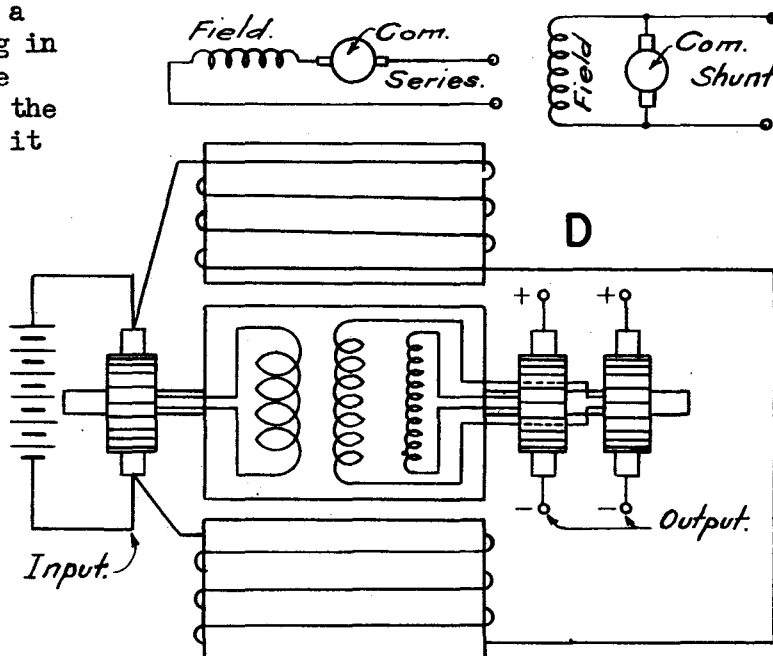

The principal troubles encountered with dynamotors is associated with commutator, brushes, bearings, and loose

BROADCAST INSTALLATION

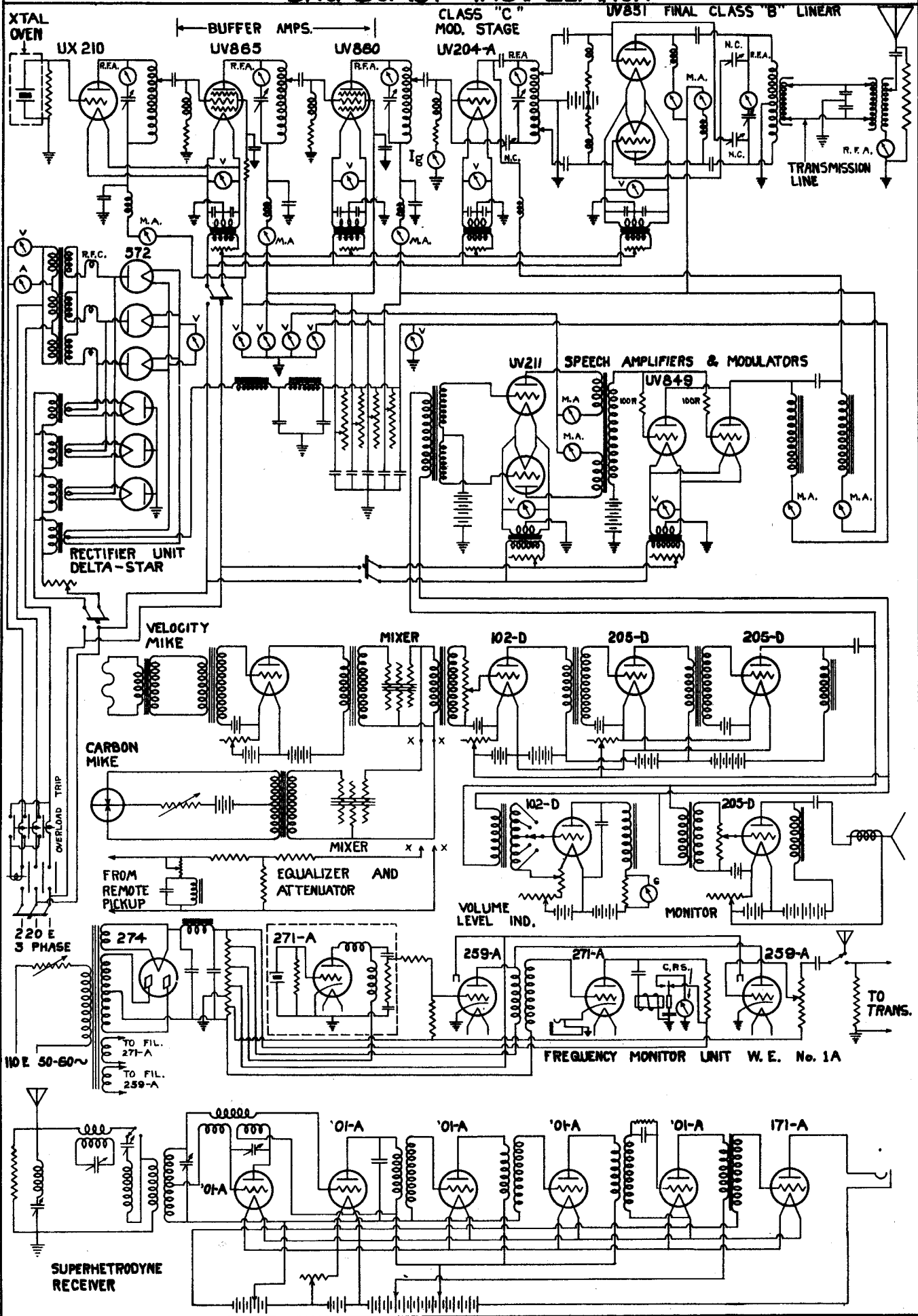

TRANSMITTER: TONE-C.W.-VOICE.

V₁ - Oscillator.
V₂ - Power amplifier.
V₃ & *V₄* - Class "B" modulators.
V₅ - Speech amp. & audio osc.
C₁ to *C₉* inc. By-pass condensers.
C₁₀ & *C₁₁* - Compensating Con.
C₁₂ & *C₁₃* - Tuning condensers.

G₁₄ - Ant. tuning condenser.
C₁₅ - Neutralizing condenser.
C₁₆ to *C₁₉* inc. Coupling condensers.

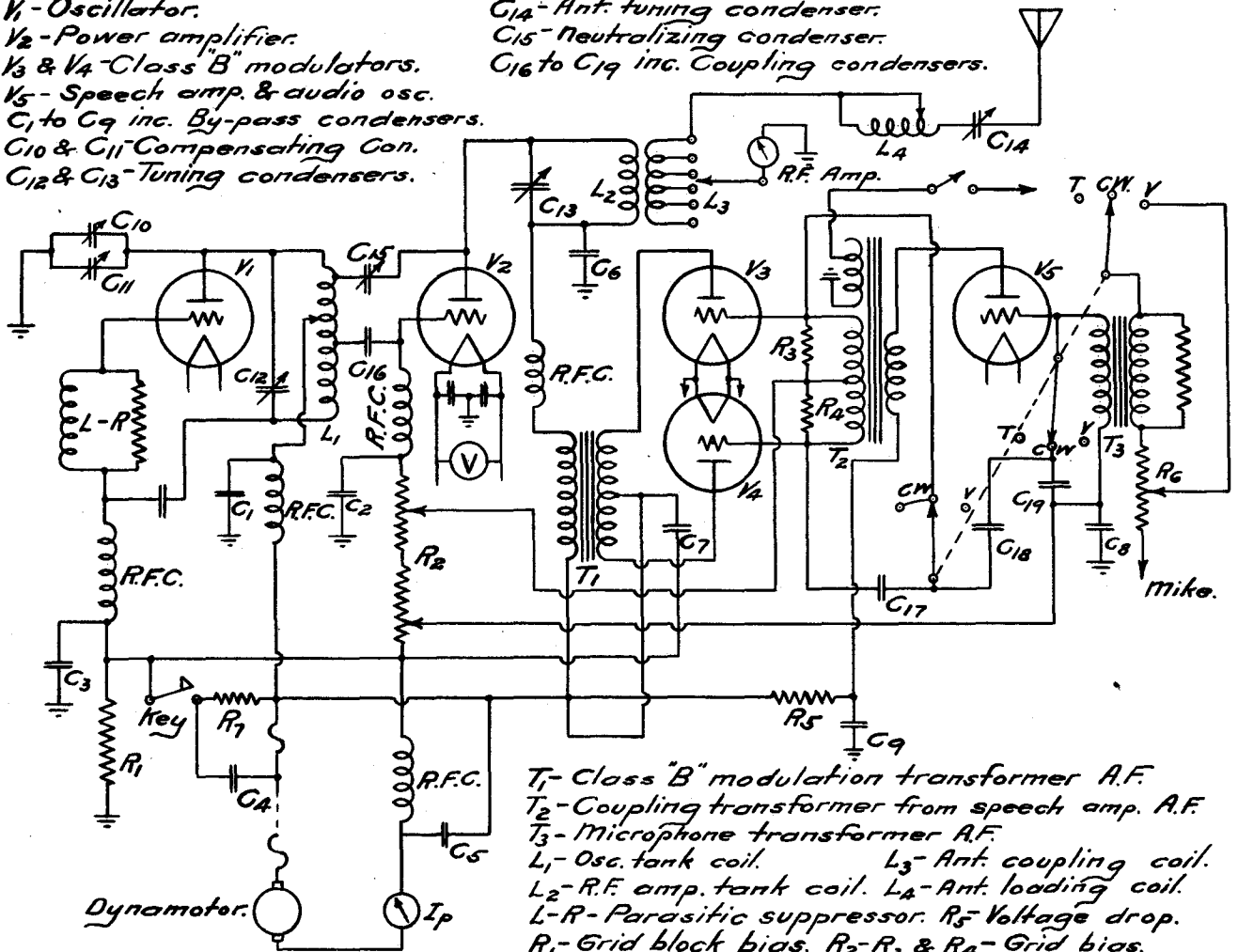

T₁ - Class "B" modulation transformer A.F.
T₂ - Coupling transformer from speech amp. A.F.
T₃ - Microphone transformer A.F.
L₁ - Osc. tank coil. *L₃* - Ant. coupling coil.
L₂ - R.F. amp. tank coil. *L₄* - Ant. loading coil.
L-R - Parasitic suppressor. *R₅* - Voltage drop.
R₁ - Grid block bias. *R₂* - *R₃* & *R₄* - Grid bias.
R₆ - Volume control. *R₇* - Key click Resistor.

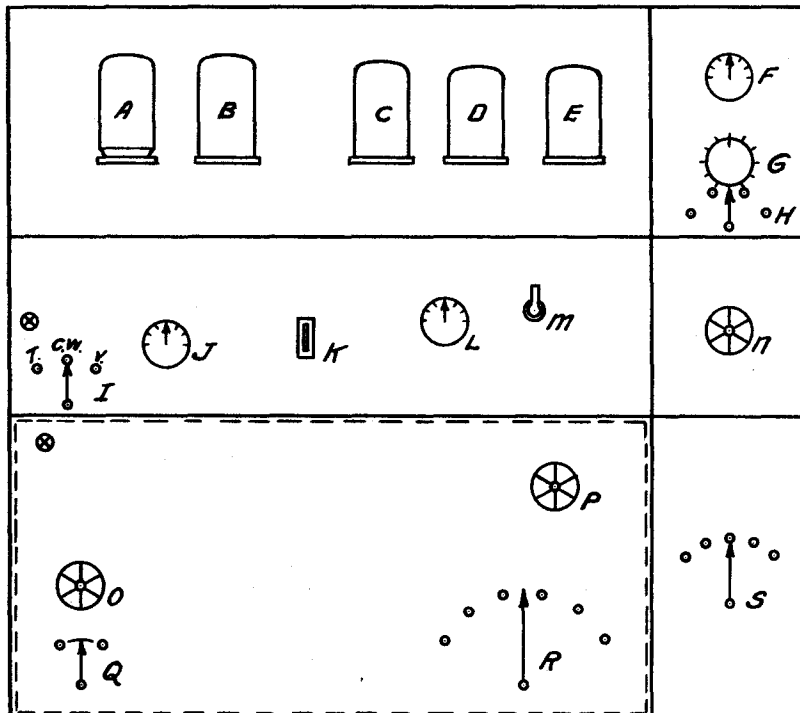

A - Speech amplifier.
B - Oscillator.
C - R.F. amp.
D - Modulator.
E - "
F - Ant. R.F. meter.
G - Variable ant. *L₄*.
H - Ant. circuit switch.
I - Signal selector. T-C.W.-V.
J - *I_p* meter.
K - *E_f* on-off switch.
L - *E_f* Voltmeter.
M - *E_f* Switch.
N - Ant. series condenser *G₁₄*.
O - Osc. tuning condenser *C₁₂*.
P - P.A. " " *C₁₃*.
Q - Band change switch.
**R* - Coupling to ant.
S - Ant. positions.
**Removable tuning unit L₃.*

WARNING:

Operation of transmitting equipment involves the use of high voltages which are dangerous to life. Operating personnel must at all times observe safety rules and regulations. Do not change tubes, or make adjustments inside equipment with high voltage on. Do not complete or maintain any connections between transmitter and dynamotor unit unless all duplicate unused sockets on the transmitter are covered with socket caps with catches properly snapped in place.

Under no condition should any of the switches on the transmitter or tuning units be changed while the key or microphone button is depressed. Failure to observe this precaution will cause undue arcing at the switch; it may cause tube failure.

PROCEDURE:

CW OPERATION

1. Select tuning unit for desired frequency.
2. Place signal switch on CW.
3. From calibration chart on panel, set band switch, master oscillator tuning control, and power amplifier tuning control for desired frequency.
4. Set antenna coupling switch to the first contact or 1.
5. Place the off-on switch in the on position. This will start the dynamotor lighting the filaments of the master oscillator power amplifier.
6. Press the key. This should cause the tubes to draw plate current.
7. Check power amplifier for resonance by varying the power amplifier control until minimum plate current is indicated. This should be approximately 80 to 110 mils.
8. Tune the antenna to resonance. As the antenna tuning control is varied through resonance, the plate current on the final power amplifier will increase to a value somewhat higher than the off-resonance value in the power amplifier proper. With an RF meter in the antenna, assuming the marconi type working against ground or counter-poise, maximum RF in the antenna meter and maximum plate current in the power amplifier will occur at the same time.

VOICE OPERATION

1. For voice operation, the above procedure must be carried out.
2. Place the signal switch in the voice position.
3. Adjust modulator bias in tube compartment until total plate current with the microphone switch depressed is about 20 mils higher than for CW.
4. Because the modulators are biased for class "B" operation, the plate current will increase to about 300 mils when the microphone switch is depressed and the voice energy applied at sustained normal level.

TONE OPERATION

1. Place signal switch on the tone position and the transmitter is then keyed for telegraph tone signal. The plate current for the transmitter will be between 300 and 350 mils.

SHIPBOARD INSTALLATION.

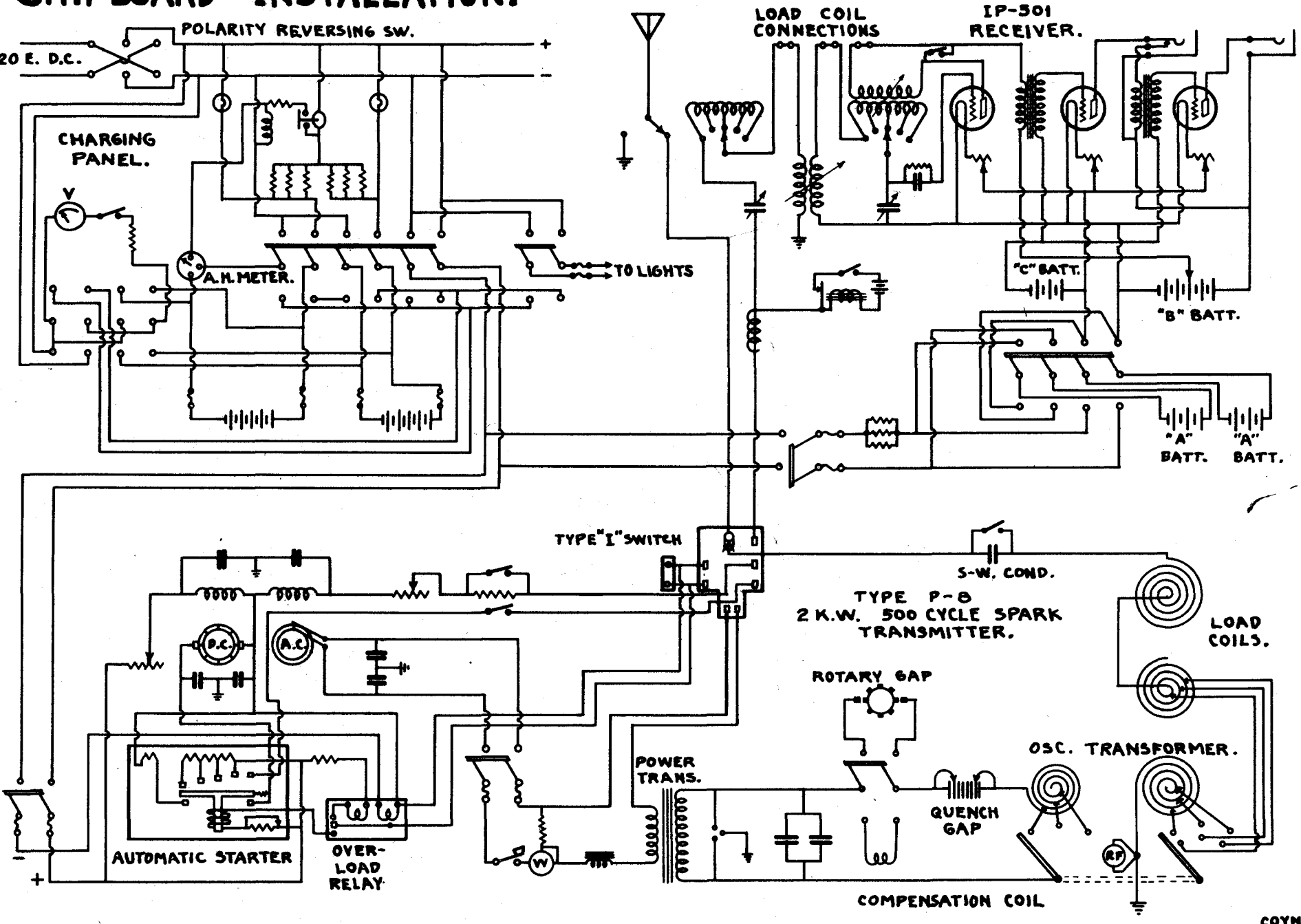

Radio Transmission and Transmitters

SHIPBOARD INSTALLATION.

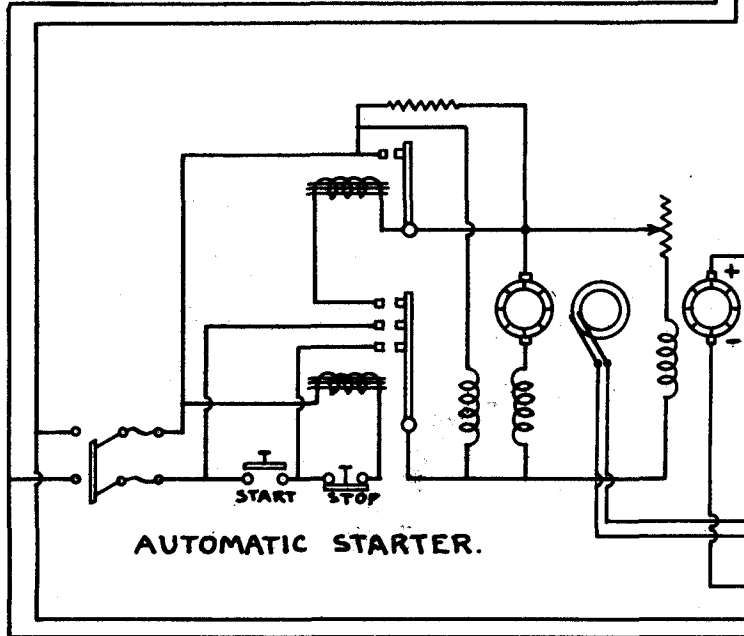
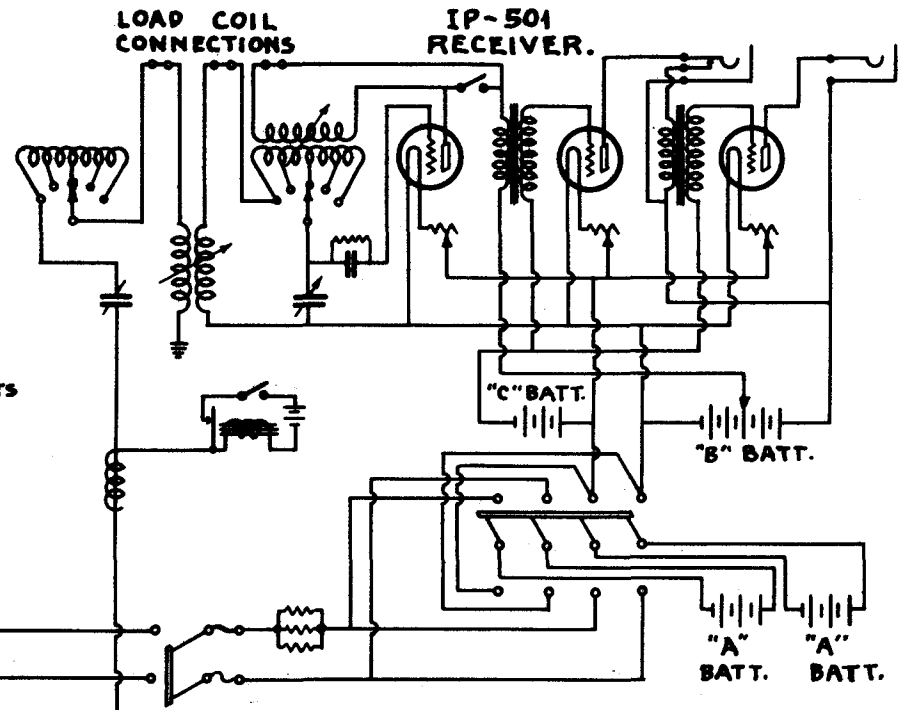
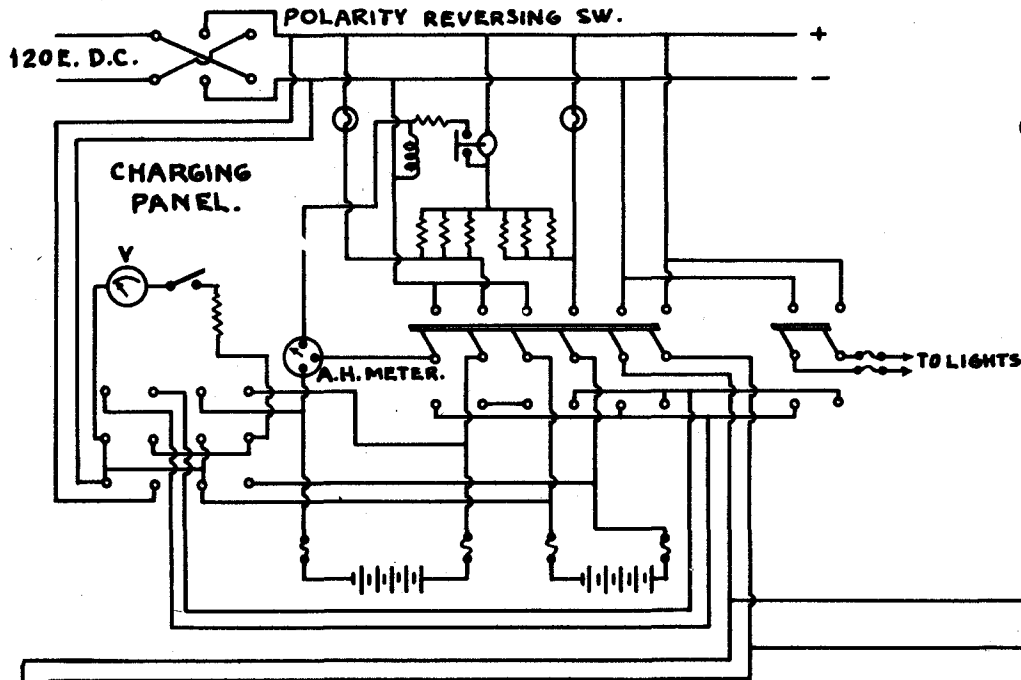

ET-3627-A 200WATT TUBE TRANSMITTER WITH RADIOPHONE ATTACHMENT.

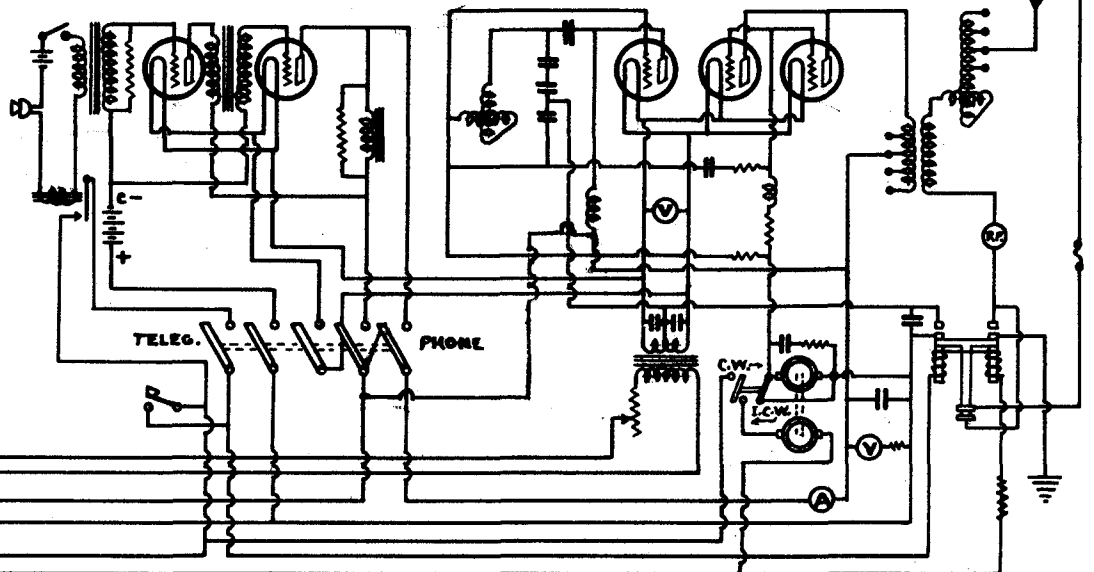

SHIPBOARD INSTALLATION.

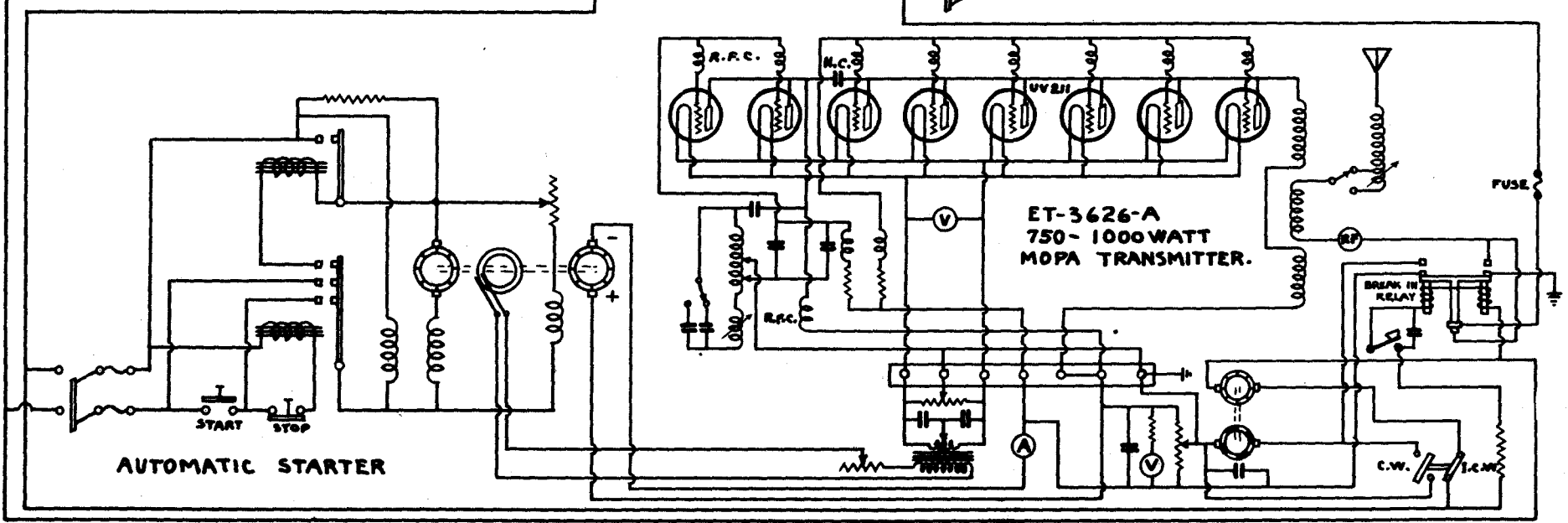
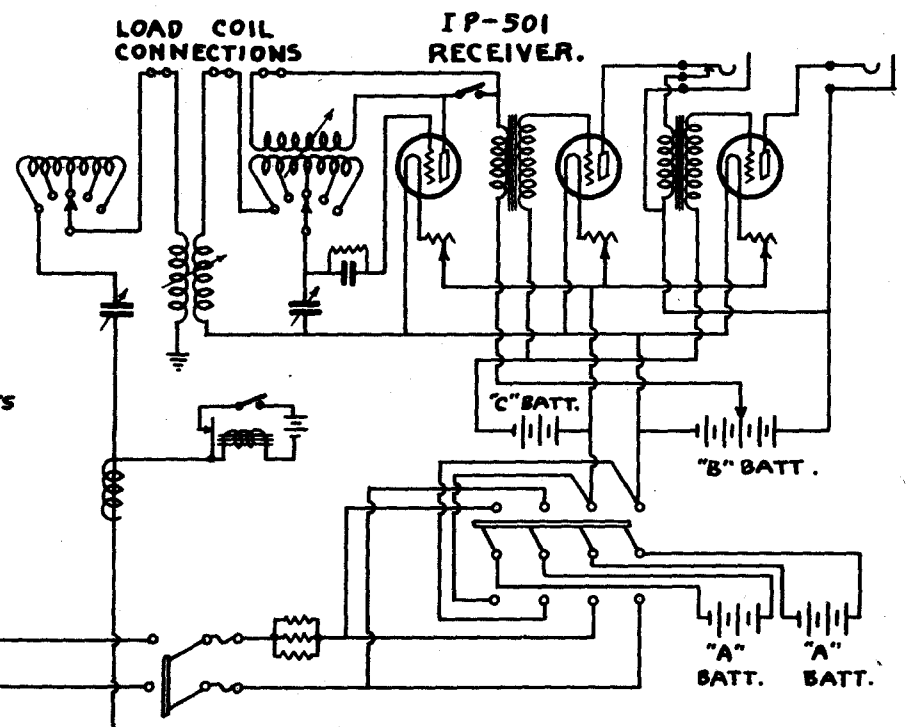
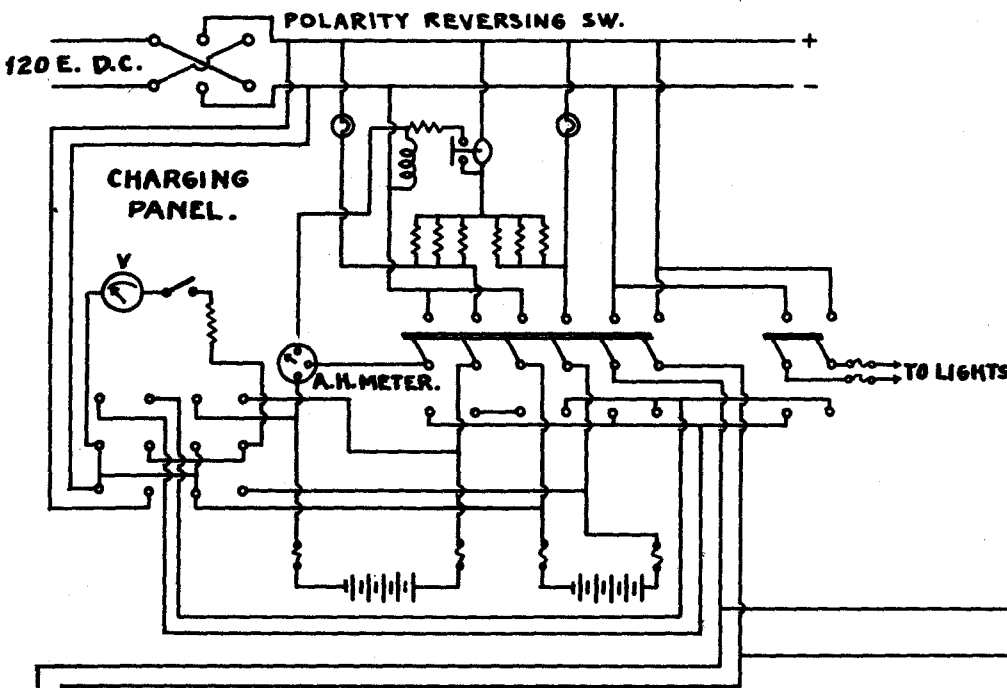

Radio Transmission and Transmitters

SHIP INSTALLATION USING ARC TRANSMITTER MODEL "Q"

λ RANGE IP 501 300-23000 RECEIVER WITH LOAD COIL

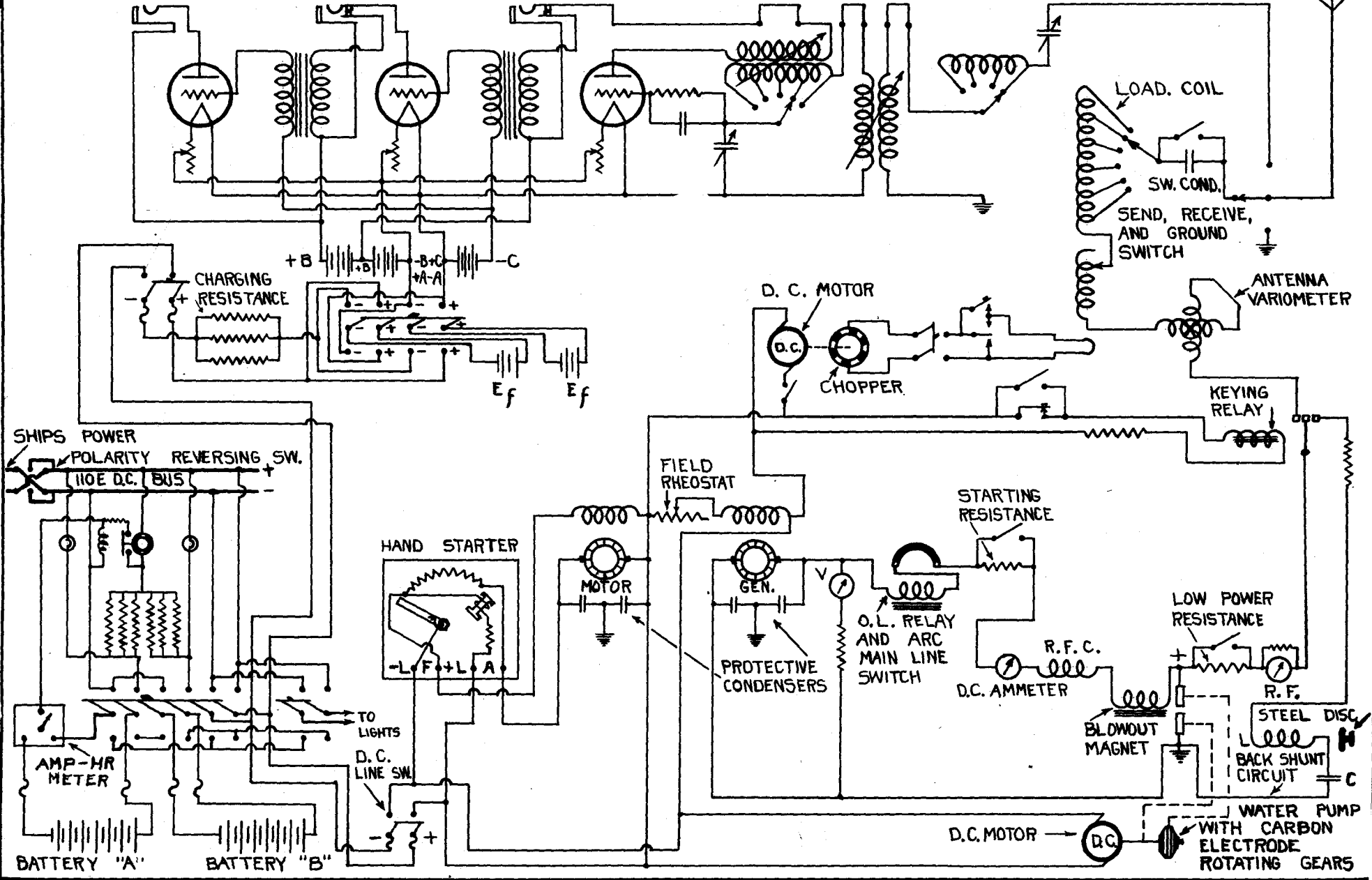

SHIPBOARD INSTALLATION.

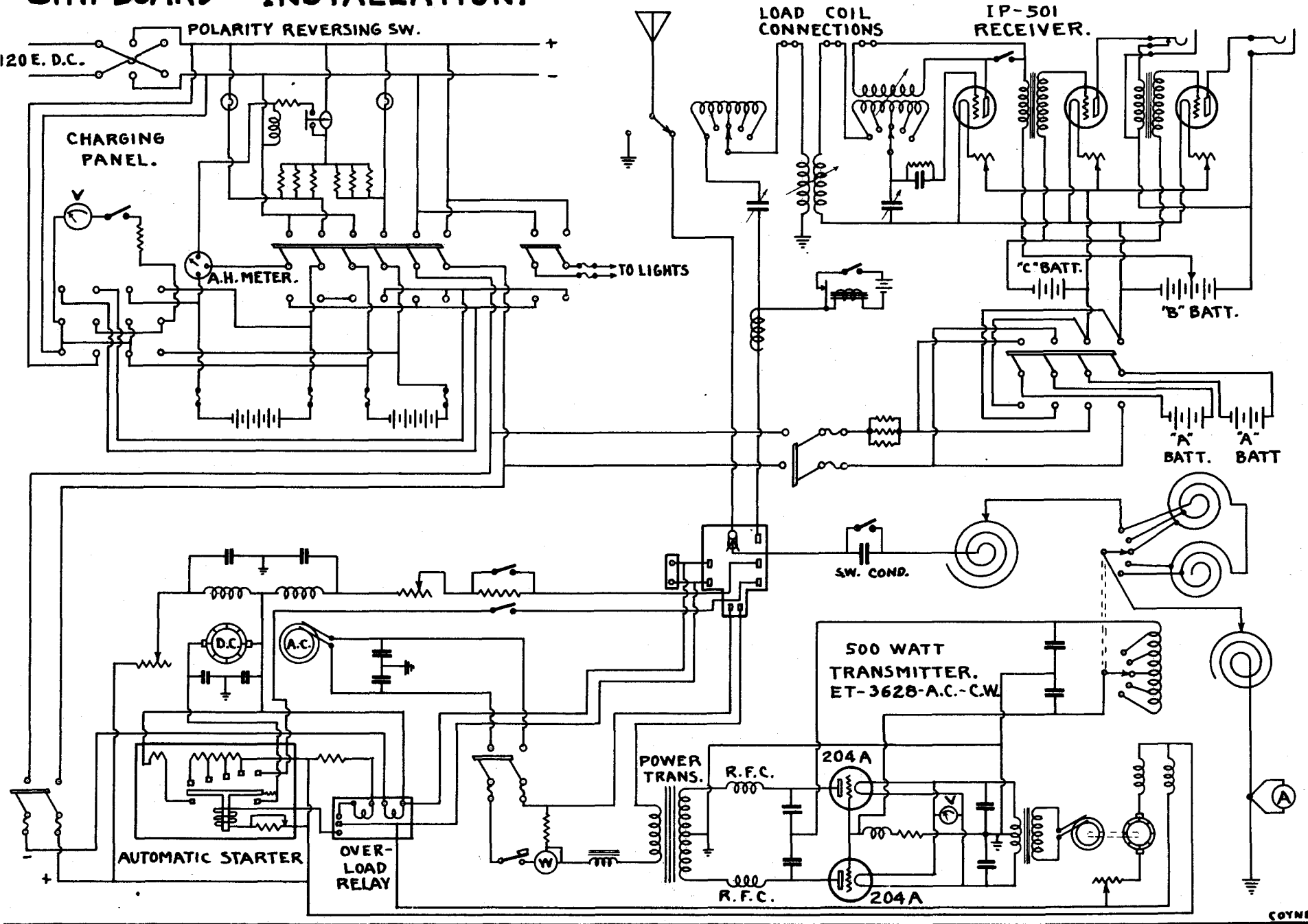

Radio Transmission and Transmitters

LIST OF ABBREVIATIONS USED IN RADIOTELEGRAPHY.

A ---	1 - - - - -	PERIOD - - - - -
B - - - - -	2 - - - - -	SEMICOLON - - - - -
C - - - - -	3 - - - - -	COMMA - - - - -
D - - - - -	4 - - - - -	COLON - - - - -
E - - - - -	5 - - - - -	APOSTROPHE - - - - -
F - - - - -	6 - - - - -	BAR INDICATING FRACTION - - - - -
G - - - - -	7 - - - - -	PARENTHESIS - - - - -
H - - - - -	8 - - - - -	INVERTED COMMAS - - - - -
I - - - - -	9 - - - - -	BREAK OR DOUBLE DASH - - - - -
J - - - - -	0 - - - - -	DISTRESS CALL - - - - -
K - - - - -		ATTENTION CALL - - - - -
L - - - - -		GENERAL INQUIRY - - - - -
M - - - - -		FROM (DE) - - - - -
N - - - - -		GO AHEAD
O - - - - -		QUESTION MARK - - - - -
P - - - - -		WAIT - - - - -
Q - - - - -		RECEIVED O.K. - - - - -
R - - - - -		POSITION REPORT - - - - -
S - - - - -		END OF MESSAGE - - - - -
T - - - - -		END OF TRANSMISSION - - - - -
U - - - - -		
V - - - - -		
W - - - - -		
X - - - - -		
Y - - - - -		
Z - - - - -		

International Abbreviations corrected list

Question	Answer
QRA What is the name of your stn.?	Name of stn. is -----
QRD Where are you bound for and from?	I am bound for --- from ---
QRG Will you indicate my exact freq?	Your exact freq is -----
QRH Does my freq vary?	Your freq varies.
QRI Is my tone regular?	Your tone varies.
QRJ Are you receiving me badly?	Cannot receive you. Sigs. are weak.
QRK Are you receiving me well?	I am receiving well.
QRM Are you being interfered with?	I am being interfered with.
QRN Are you troubled by static?	I am troubled by static.
QRQ Shall I send faster?	Transmit faster at speed of -- per min.
QRS Shall I send slower?	Transmit at a speed of --- per min.
QRT Shall I stop transmission?	Stop transmission.
QRU Have you anything for me?	I have nothing for you.
QRV Are you ready?	I am ready.
QRX Must I wait?	Please wait I will call you at -----
QRZ By whom am I being called?	You are being called by -----
QRW Must I advise -- that you are calling him?	Please advise --- that I am calling him on --- KC (or meters)
QRO Must I increase power?	Increase power.
QRP Must I decrease power?	Decrease power.
QRL Are you busy?	I am busy. Please do not interfere.

OPERATING

"LEARNING THE CODE"

DOT LETTERS	DASH LETTERS	LETTERS ENTIRELY DISSIMILAR
E •	T —	C — • — •
I • •	M — —	Z — — • •
S • • •	O — — —	J • — — —
H • • • •		
LETTERS THAT ARE OPPOSITE		NUMBERS
A • —	N — •	0 — — — —
U • • —	D — • •	1 • — — — — 9 — — — — •
V • • • —	B — • • •	2 • • — — — 8 — — — • •
W • — — —	G — — • •	3 • • • — — 7 — — • • •
F • • — •	L • — • •	4 • • • • — 6 — • • • •
P • — — •	X • • • • —	5 • • • • •
Y — • — — —	Q — — • • —	
R • — •	K • — • —	

First learn to distinguish the different letters and figures by their sound rather than by the number of dots and dashes contained in them.

This means that the particular letter or signal should be thought of the same as if it were a spoken word.

The procedure is something like learning a new set of ABC's, and can be considered from that angle.

The art of learning the sounds of the individual letters, etc., is a mental process, and when such intelligence is conveyed to a sheet of paper, the mind and the hand MUST work together, which calls for concentration.

Learning the letters by groups as indicated in the chart helps to relieve the monotony somewhat, the accomplishment of being able to master a job in steps is encouraging in itself, and after one group is learned the rest should follow much easier.

The initial learning of the letters must be accomplished by the individual alone, after that, copying from another person or tape machine is most beneficial. In this case, it requires the individual to do two things, namely, think of the letter, and copy it down on paper.

When copying from another person try and practice reading a little behind the sending, (never ahead). Do not anticipate what the letter or word is going to be, because when under conditions of a test, (which may consist of most any type of material) such a letter or word may not materialize which causes the person copying to become disturbed and probably miss several other words or groups.

DO NOT SEND FASTER THAN YOU CAN RECEIVE. This practice does not accomplish anything other than to convey to the person you are working with that you are a speed artist, but when he returns the compliment, the picture is changed somewhat, and YOU will have to request a slower speed.

Using a BUG is to be discouraged until you have mastered the code entirely, to a point where you can send on a straight key at least 20 words per minute intelligently without errors. ALL GOVERNMENT SENDING TESTS ARE CARRIED OUT ON STRAIGHT

SUPERHETRODYNE RECEIVER WITH BEAT FREQUENCY OSCILLATOR. FOR C.W. RECEPTION.

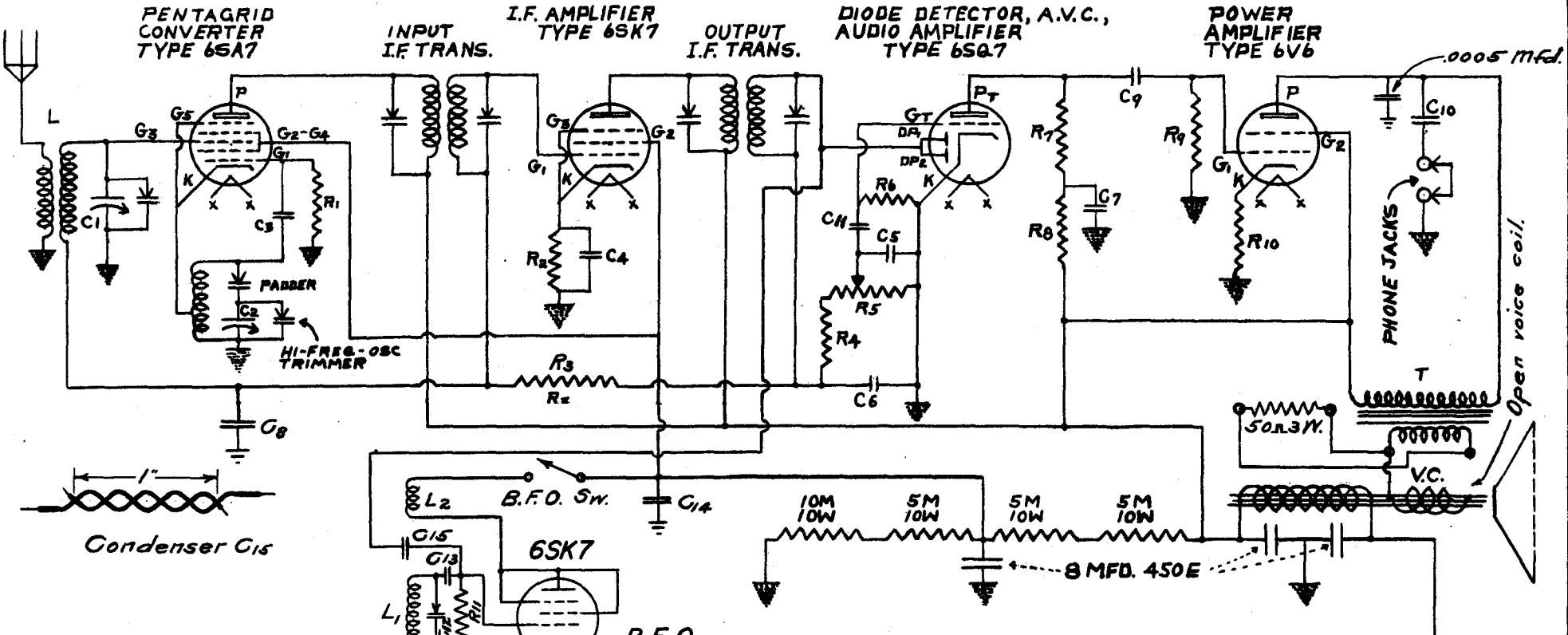

RECEIVER PARTS

- C₁ & C₂ = gauged tuning cond.
- C₃ = .00005 mfd. "
- C₄ = .05 " "
- C₅ = .00025 " "
- C₆ = .1 " "
- C₇ = .01 " "
- C₈ = .025 " "
- C₉ = .005 " "
- C₁₀ = ANT. coil
- C₁₁ = 20 M Ω
- C₁₂ = 250 Ω
- C₁₃ = 2 Meg. Ω

- R₁ & R₈ = 50 M Ω
 - R₂ = 250 M Vol. Control
 - R₃ = 10 Meg. Ω
 - R₄ = 250 M Ω
 - R₅ = 500 M Ω
 - R₆ = 250 Ω 1 W
 - R₇ = 250 Ω 1 W
 - R₉ = 250 Ω 1 W
 - R₁₀ = 250 Ω 1 W
- All Resistors except R₁₀ are 1/2 watt
- T = output transformer
 - F.C. = field coil
 - V.C. = voice coil

PARTS FOR B.F.O.

- R₁₁ = 50 M Ω
- C₁₂ = .0005 mfd. Padder
- C₁₃ = .0005 mfd. cond.
- C₁₄ = .01 " "
- C₁₅ = 1" of twisted insulated hook-up wire
- L₁ = 130 turns of #30 E.C. Wire
- L₂ = 37 turns of #30 E.C. Wire
- 1 = 4 Prong Socket
- 1 = 8 " "

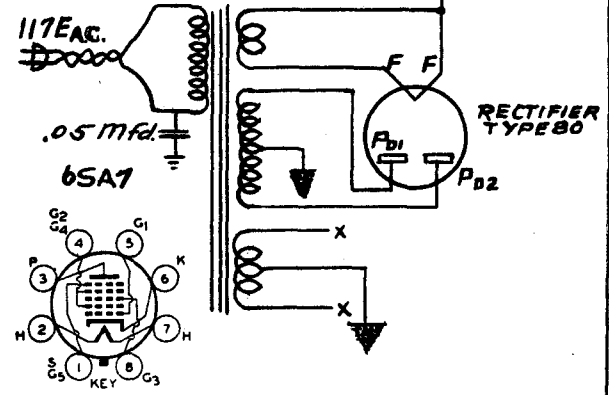

LONGITUDE AND TIME.

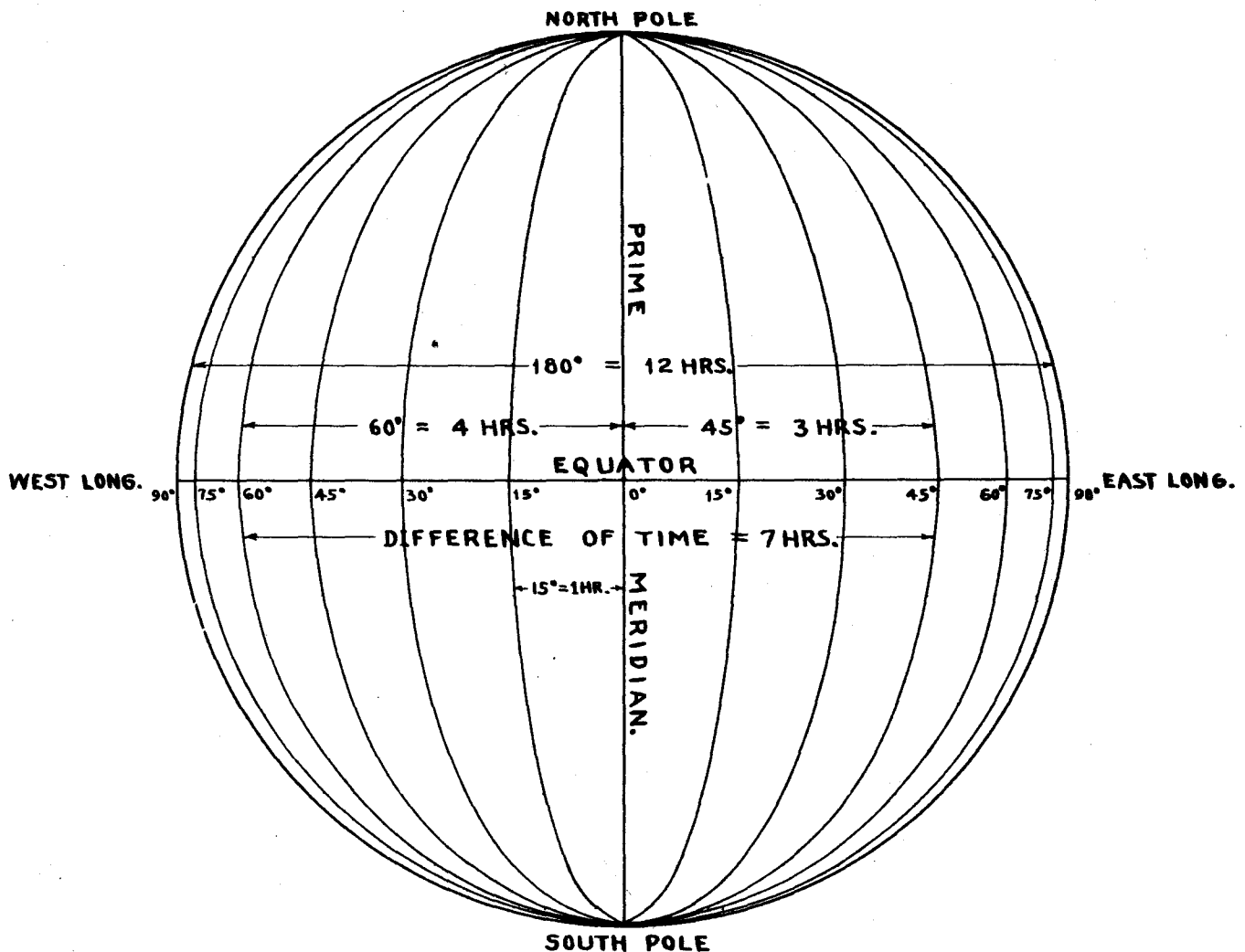

A point on any plane can be located by two measures taken from two intersecting lines.

Measurements are made from equator and Prime Meridian in degrees, minutes, and seconds.

Longitude is the distance east or west of the Prime Meridian.

The earth rotates on its axis from west to east. Motion of the earth causes the sun to appear to move from east to west. Earlier time west; later time east. When it is noon on any Meridian it will be one o'clock P.M. 15° east of that Meridian, and 11 o'clock A.M. 15° west of it.

Since the earth turns on its axis once in every 24 hours, every point on the earth's surface passes under the sun's rays every 24 hrs.

Consequently 360° of the earth's surface pass under the sun's rays in 24 hours.

Therefore;

360° of Long. - 24 hours of time.

1° of Long. - $1/360$ of 24 hr. - 4 min.

$1'$ or Long. - $1/60$ of 4 min. - 4 sec.

$1''$ or Long. - $1/60$ of 4 sec. - $1/15$ sec.

Consequently the difference in Long. equals fifteen times the difference in time. The motion of the sun is only apparent.

The Prime Meridian passes thru. Washington D.C. for U.S.A., thru. Greenwich for England, and thru. Paris for France.

In reckoning time in Canada and U.S.A. Longitude is usually measured from the Meridian of Greenwich.

WINDCHARGER.

TOP VIEW

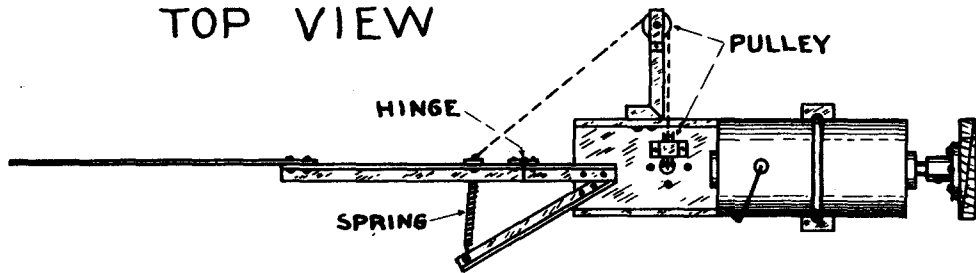

SIDE VIEW

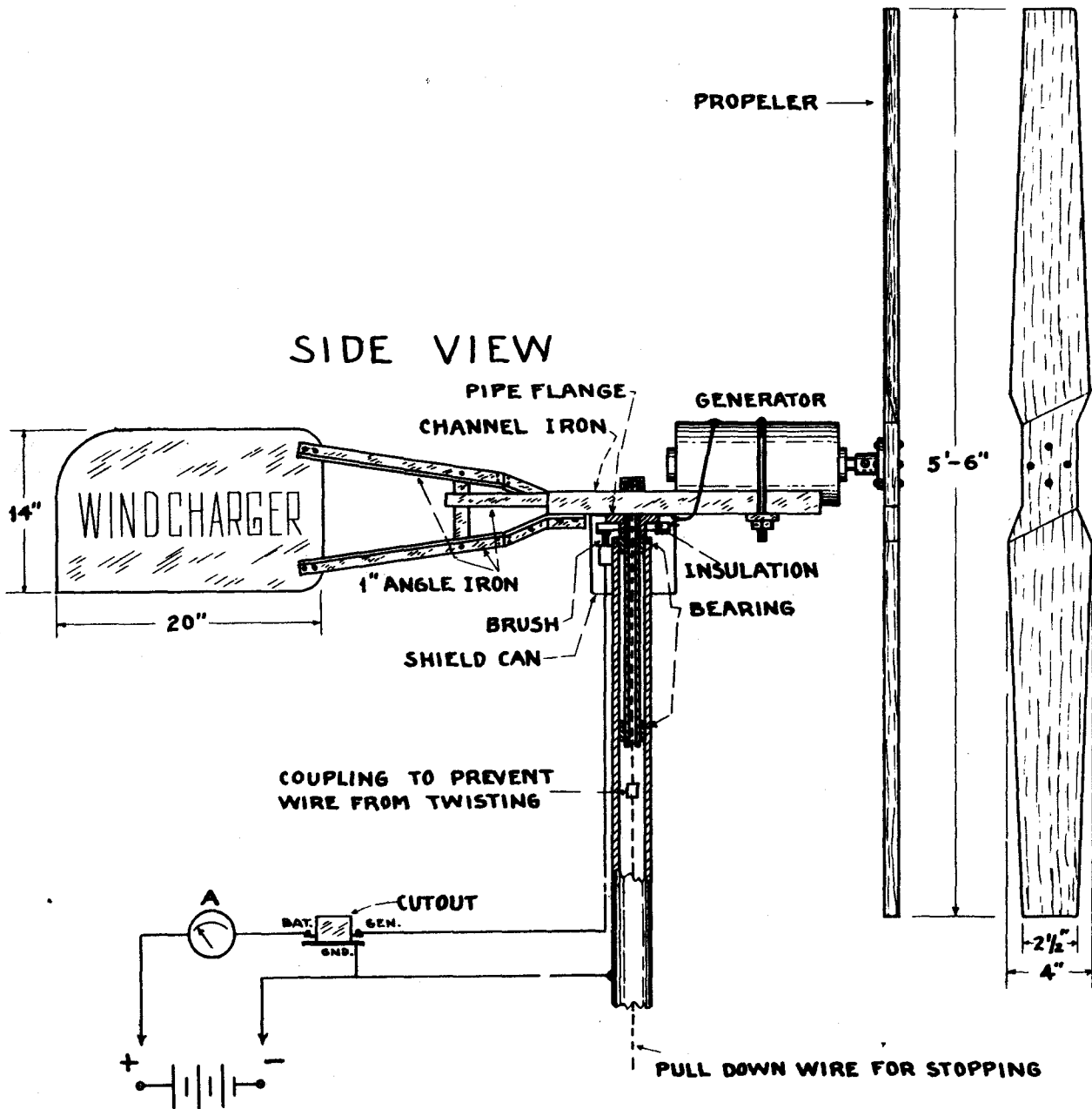

VOLTAGE GENERATED BY REVOLVING CONDUCTOR.

When a conductor moves in a magnetic field the voltage induced in it depends upon:

1. The strength of the field
2. The speed of the conductor
3. The direction of motion of the conductor with respect to the field.

In all diagrams on this sheet, the conductor is assumed to move at a constant angular velocity. In diagram A the conductor is moving parallel to the field; therefore, no voltage is generated.

In diagram B the conductor is moving thru the flux at an angle and the rate of cutting of lines of force has increased. Sketch B₁ shows the effect of the changing direction of conductor motion.

In Figure C the conductor is moving across the flux at a different angle and, as can readily be seen by referring to Fig. C₁ the number of lines of force cut per degree of angular motion has increased.

In Figure D the conductor is moving at right angles to the flux and is therefore cutting lines of force at the maximum rate. The induced voltage at this point in the rotation is therefore maximum.

In Fig. E the angle at which the conductor is moving with respect to the lines of force is diminishing. The rate of cutting of lines of force is therefore reduced, and the generated voltage is less than in Fig. D. The manner in which the voltage varies from point to point as the conductor rotates is shown on the opposite side of the sheet.

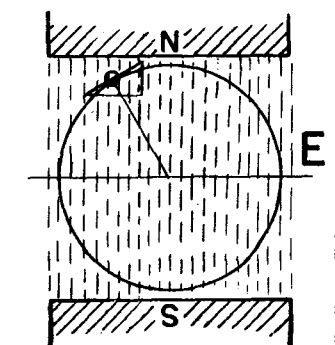
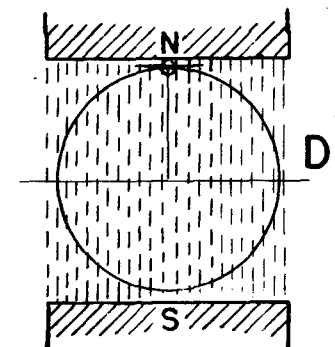
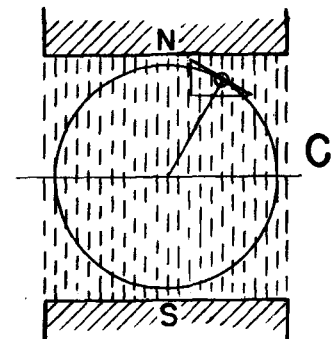
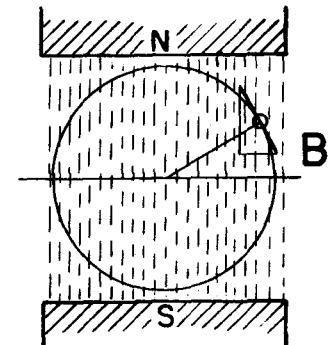
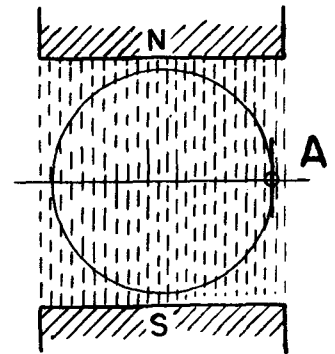
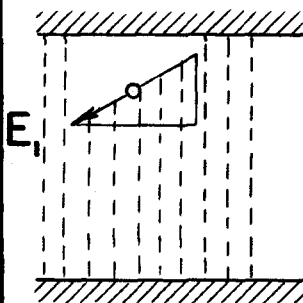
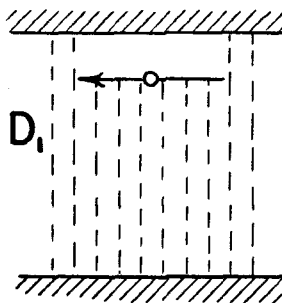
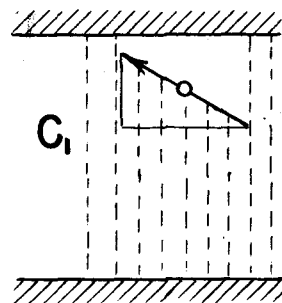
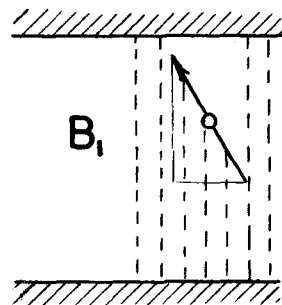
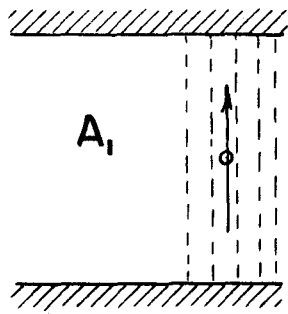

DEVELOPMENT OF THE SINE CURVE.

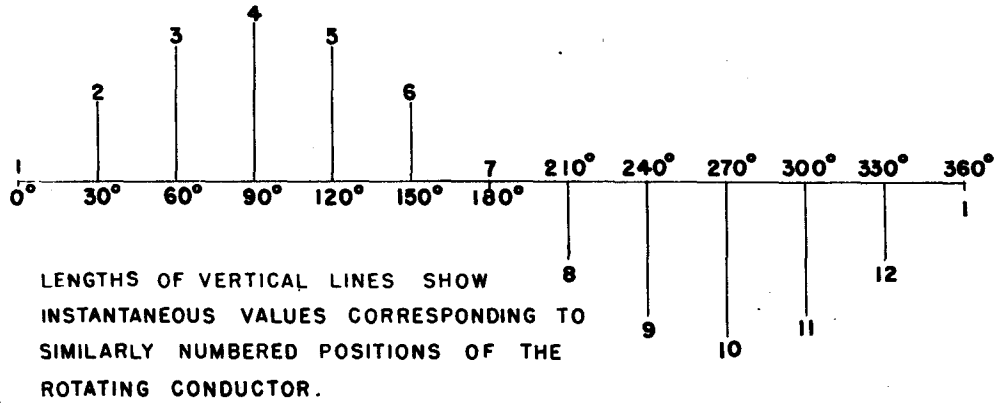
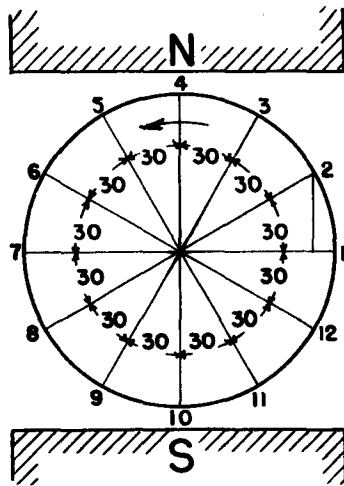

These values are based on the assumption that the conductor moves at constant angular velocity thru a magnetic field of uniform strength.

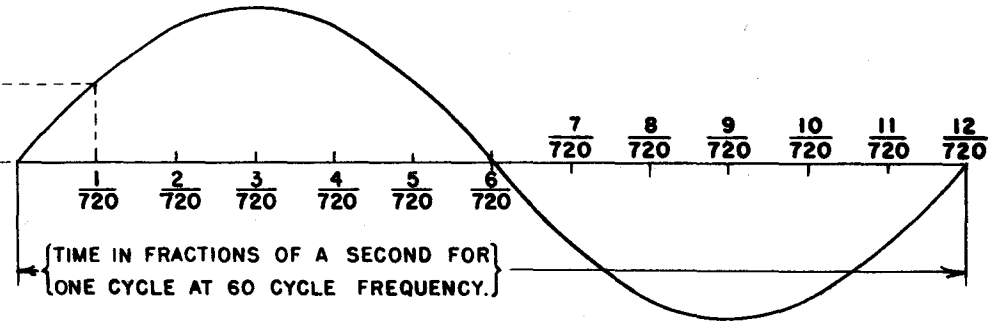
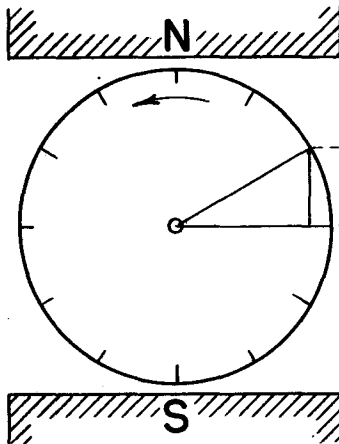

The smooth curve above shows the manner in which the generated voltage varies from instant to instant. The distance of the curve from the base line at any point is a measure of the voltage generated at that instant.

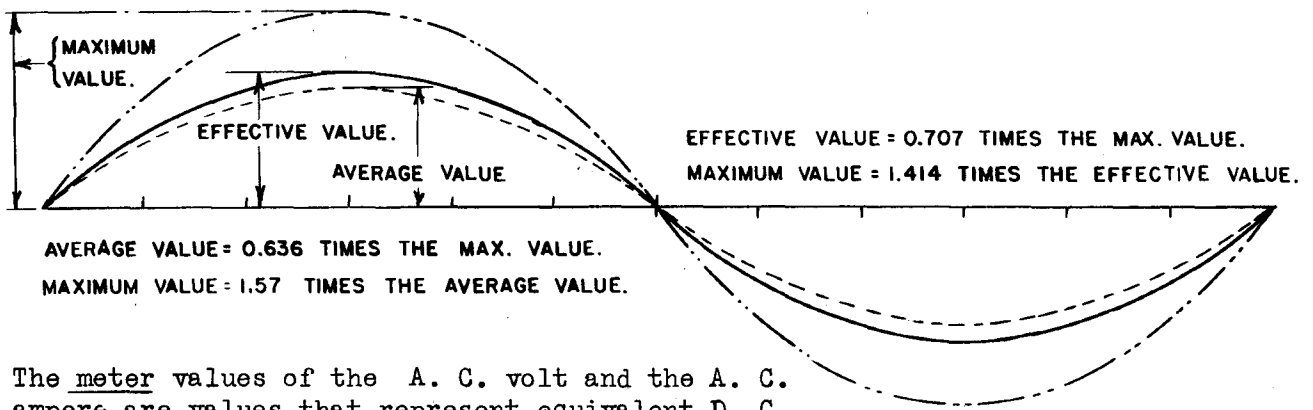

The meter values of the A. C. volt and the A. C. ampere are values that represent equivalent D. C. values. An A. C. current that will produce the same heating effect as a D. C. current of one ampere is said to have an effective value of one A. C. ampere. Note that the curve of effective values is somewhat lower than the curve of maximum values, and slightly higher than the curve of average values.

TROUBLE SHEET #1

TYPE OF TROUBLE 520 SHEET #	OPERATE AND NOTE SYMPTOM	RESISTANCE VALUES					E AND I VALUES					REASON FOR IN- CORRECT READING	REMEDY		
		CIRCUIT TESTED	N	H	L	O _Ω	N-R _g	TESTS MADE	N	O	L			H	
#1 - OPEN G ₁ CIRCUIT IN IF STAGE	NO SIGNAL	P						I _p					BROKEN WIRE	REPLACE	
	OSCILLATES	G ₁						E _p					POOR CONTACT	INSULATE	
	WEAK VOLUME	G ₂						E _{g2}					OPEN UNIT	CLEAN	
	DISTORTED	G ₃						E _{g1}					SHORTED UNIT	SOLDER	
	MOTORBOATS	K						E _k					GROUND	REPAIR	
#2 SHORTED CATHODE BY-PASS CONDENSER IN IN STAGE	NO SIGNAL	P						I _p					BROKEN WIRE	REPLACE	
	OSCILLATES	G ₁						E _p					POOR CONTACT	INSULATE	
	WEAK VOLUME	G ₂						E _{g2}					OPEN UNIT	CLEAN	
	DISTORTED	G ₃						E _{g1}					SHORTED UNIT	SOLDER	
	MOTORBOATS	K						E _k					GROUND	REPAIR	
#3 - OPEN GRID BIAS RESISTOR IN OUTPUT STAGE	NO SIGNAL	P						I _p					BROKEN WIRE	REPLACE	
	OSCILLATES	G ₁						E _p					POOR CONTACT	INSULATE	
	WEAK VOLUME	G ₂						E _{g2}					OPEN UNIT	CLEAN	
	DISTORTED	G ₃						E _{g1}					SHORTED UNIT	SOLDER	
	MOTORBOATS	K						E _k					GROUND	REPAIR	
#4 OPEN PLATE IN PENTAGRID CONVERTER CIRCUIT	NO SIGNAL	P						I _p					BROKEN WIRE	REPLACE	
	OSCILLATES	G ₁						E _p					POOR CONTACT	INSULATE	
	WEAK VOLUME	G ₂ & G ₄						E _{g2} & 4					OPEN UNIT	CLEAN	
	DISTORTED	G ₃						E _{g3}					SHORTED UNIT	SOLDER	
	MOTORBOATS	G ₅ & K						E _{g5} & E _k					GROUND	REPAIR	
#4 OPEN PLATE CIRCUIT IN IF STAGE	NO SIGNAL	P						I _p					BROKEN WIRE	REPLACE	
	OSCILLATES	G ₁						E _p					POOR CONTACT	INSULATE	
	WEAK VOLUME	G ₂						E _{g2}					OPEN UNIT	CLEAN	
	DISTORTED	G ₃						E _{g1}					SHORTED UNIT	SOLDER	
	MOTORBOATS	H						E _k					GROUND	REPAIR	
#5 - OPEN SCREEN GRID CIRCUIT IN OUTPUT STAGE	NO SIGNAL	P						I _p					BROKEN WIRE	REPLACE	
	OSCILLATES	G ₁						E _p					POOR CONTACT	INSULATE	
	WEAK VOLUME	G ₂						E _{g2}					OPEN UNIT	CLEAN	
	DISTORTED	K						E _{g1}					SHORTED UNIT	SOLDER	
	MOTORBOATS	H						E _k					GROUND	REPAIR	
#6 OPEN CONNECTION FROM CENTER TAP OF HEATER WINDING TO GROUND	NO SIGNAL	P	ALL TUBES					I _p	ALL TUBES					BROKEN WIRE	REPLACE
	OSCILLATES	G ₁						E _p						POOR CONTACT	INSULATE
	WEAK VOLUME	G ₂						E _{g2}						OPEN UNIT	CLEAN
	DISTORTED	G ₃						E _{g1}						SHORTED UNIT	SOLDER
	MOTORBOATS	K						E _k						GROUND	REPAIR

Radio Testing and Adjustment

TROUBLE SHEET #2

TYPE OF TROUBLE 520 SHEET #	OPERATE AND NOTE SYMPTOM	RESISTANCE VALUES					E AND I VALUES					REASON FOR IN- CORRECT READING	REMEDY	
		CIRCUIT TESTED	N	H	L	O ₂	N-R _g .	TESTS MADE	N	O	L			H
#8 - OPEN HEATER CIRCUIT IN OUTPUT STATE	NO SIGNAL	P						I _p					BROKEN WIRE	REPLACE
	OSCILLATES	G ₁						E _p					POOR CONTACT	INSULATE
	WEAK VOLUME	G ₂						E _{g2}					OPEN UNIT	CLEAN
	DISTORTED	K						E _{g1}					SHORTED UNIT	SOLDER
	MOTORBOATS	H						E _h					GROUND	REPAIR
#9 - SHORTED SCREEN GRID BY-PASS COND. IN IF STAGE	NO SIGNAL	P						I _p					BROKEN WIRE	REPLACE
	OSCILLATES	G ₁	ALL TUBES					E _p	ALL TUBES				POOR CONTACT	INSULATE
	WEAK VOLUME	G ₂	ALL TUBES					E _{g2}	ALL TUBES				OPEN UNIT	CLEAN
	DISTORTED	G ₃	ALL TUBES					E _{g1}	ALL TUBES				SHORTED UNIT	SOLDER
	MOTORBOATS	K	ALL TUBES					E _k	ALL TUBES				GROUND	REPAIR
#10 - SHORTED COUPLING COND. FEEDING OUT- PUT STAGE	NO SIGNAL	P						I _p					BROKEN WIRE	REPLACE
	OSCILLATES	G ₁	OUTPUT TUBE					E _p	OUTPUT TUBE				POOR CONTACT	INSULATE
	WEAK VOLUME	G ₂	OUTPUT TUBE					E _{g2}	OUTPUT TUBE				OPEN UNIT	CLEAN
	DISTORTED	K	OUTPUT TUBE					E _{g1}	OUTPUT TUBE				SHORTED UNIT	SOLDER
	MOTORBOATS	H	OUTPUT TUBE					E _k	OUTPUT TUBE				GROUND	REPAIR
#11 - SHORTED PLATE BY-PASS CONDENSER IN 1st AF STAGE	NO SIGNAL	P _t						I _{pt}					BROKEN WIRE	REPLACE
	OSCILLATES	G _t						E _{pt}					POOR CONTACT	INSULATE
	WEAK VOLUME	P _{d1}						E _{gt}					OPEN UNIT	CLEAN
	DISTORTED	P _{d2}						E _{gd1}					SHORTED UNIT	SOLDER
	MOTORBOATS	K						E _k					GROUND	REPAIR
#12 - OPEN BLEEDER RESISTOR	NO SIGNAL	P						I _p					BROKEN WIRE	REPLACE
	OSCILLATES	G ₁	ALL TUBES					E _p	ALL TUBES				POOR CONTACT	INSULATE
	WEAK VOLUME	G ₂	ALL TUBES					E _{g2}	ALL TUBES				OPEN UNIT	CLEAN
	DISTORTED	G ₃	ALL TUBES					E _{g1}	ALL TUBES				SHORTED UNIT	SOLDER
	MOTORBOATS	K	ALL TUBES					E _k	ALL TUBES				GROUND	REPAIR
#15 - OPEN IN B- CLESE TO RECTIFIER	NO SIGNAL	P						I _p					BROKEN WIRE	REPLACE
	OSCILLATES	G ₁	ALL TUBES					E _p	ALL TUBES				POOR CONTACT	INSULATE
	WEAK VOLUME	G ₂	ALL TUBES					E _{g2}	ALL TUBES				OPEN UNIT	CLEAN
	DISTORTED	G ₃	ALL TUBES					E _{g1}	ALL TUBES				SHORTED UNIT	SOLDER
	MOTORBOATS	K	ALL TUBES					E _k	ALL TUBES				GROUND	REPAIR
#16 - SHORTED INPUT FILTER CONDENSER THROUGH 500 RESISTOR	NO SIGNAL	P						I _p					BROKEN WIRE	REPLACE
	OSCILLATES	G ₁	ALL TUBES					E _p	ALL TUBES				POOR CONTACT	INSULATE
	WEAK VOLUME	G ₂	ALL TUBES					E _{g2}	ALL TUBES				OPEN UNIT	CLEAN
	DISTORTED	G ₃	ALL TUBES					E _{g1}	ALL TUBES				SHORTED UNIT	SOLDER
	MOTORBOATS	K	ALL TUBES					E _k	ALL TUBES				GROUND	REPAIR

VOLTAGE DISTRIBUTION IN THE D.C. CIRCUIT.

To determine the difference in electrical pressure between two points in a circuit, it is first of all necessary to establish a reference point.

Unless otherwise specified, the negative terminal of any D.C. source is regarded as the reference point, and the difference in pressure between this terminal and any other point in the circuit is called the voltage of that point.

If the point in question has a voltage that is higher than the reference point it is marked (+), if lower it is marked (-). Thus point "d" in Fig. A is marked -8.2 whereas point "h" in Fig. C is marked -7.5 volts, for the last figure indicates that point "h" has a pressure that is 7.5 volts below the reference point "e" which is used in Fig. C.

In Fig. A and B, in which the negative terminal of the battery or point "a" is used as the reference, it is evident that the voltage rises through the battery and falls through each resistance until the reference value is reached.

In Fig. C the reference point has been changed from "a" to "e". With respect to this new reference point, the voltages of the various points will be different from those indicated in Fig. B. Note that points f, g, h, j, and a have pressures below the reference value, and points b, c, and d have voltages above the reference point "e".

It is usual to regard the pressure at the reference point as zero. All points above this value are marked (+), all below are marked (-)

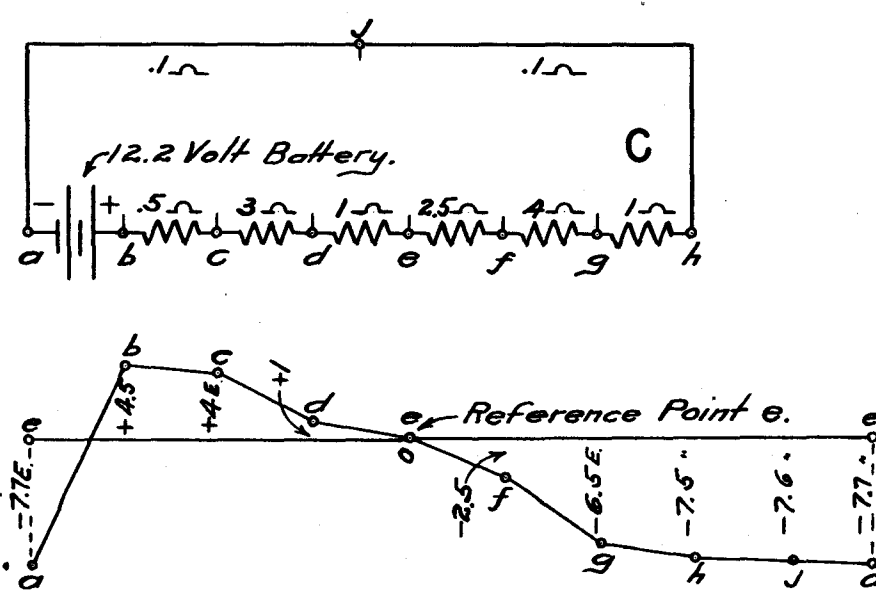
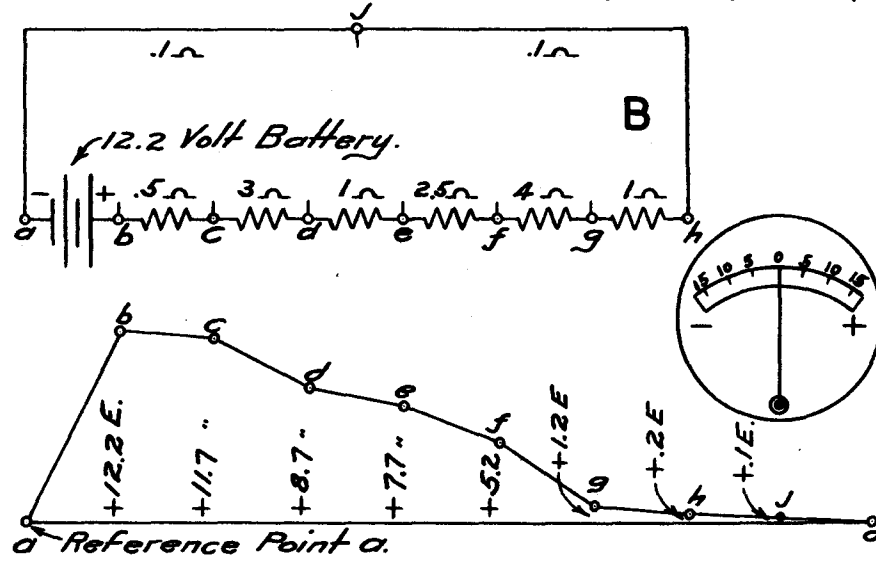
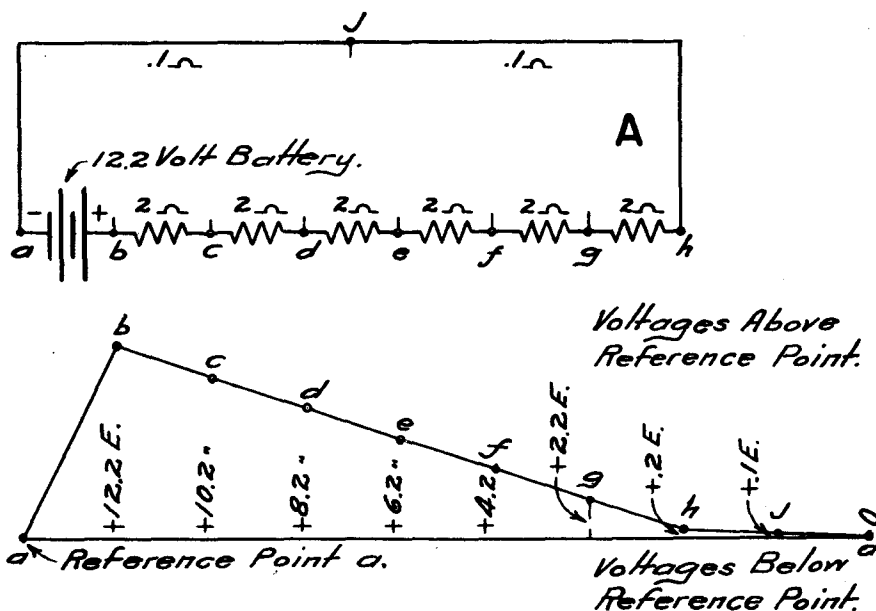

VOLTAGE DISTRIBUTION IN THE D.C. CIRCUIT.

Figure D shows a more complex circuit in which several batteries are employed, and graphs E, F, and G indicate the voltages at different points in this circuit.

As the positive terminal of a source of supply is at a higher electrical pressure than the negative, it follows that, in passing through a battery from neg. to pos., the pressure rises. When passing through the battery from pos. to neg. the pressure falls.

As all batteries have internal resistance, the terminal voltage of the battery is diminished by the IR drop caused by current flowing through this internal resistance. This explains why the open circuit voltage of a cell is higher than the closed circuit voltage.

In graph E is shown the manner in which the voltage of the different points changes. As F is used as the reference point, and as all points in the circuit have a lower pressure than this point, all values are plotted below the reference line.

In graph F the reference point has been moved to E. As this is the point of lowest pressure in the circuit, all other points have their voltage higher and are plotted above the reference line.

In Graph G the point chosen as the reference has a voltage that is approximately midway between the other two (electrically) therefore, there are some points that are higher in pressure than point A and some that are lower.

If one terminal of a sensitive voltmeter with a center zero were connected to the reference, the reading of the instrument would correspond to the values indicated on the various graphs.

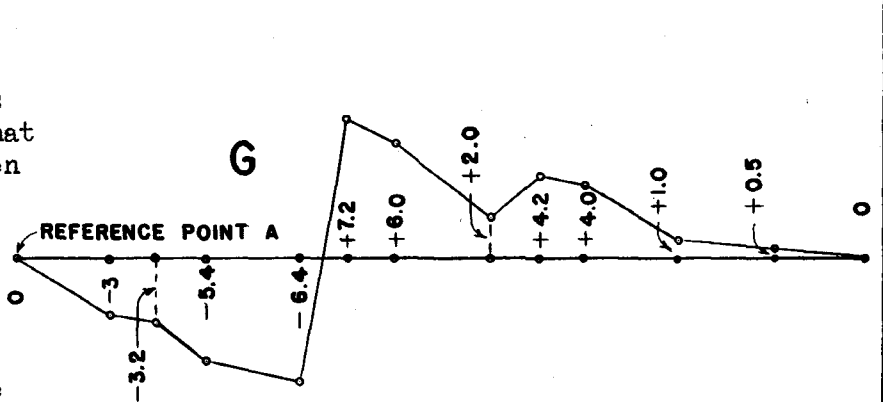
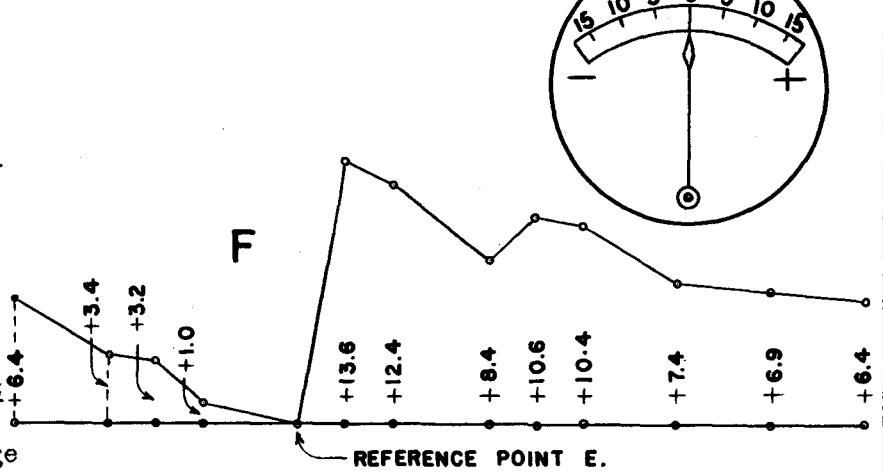
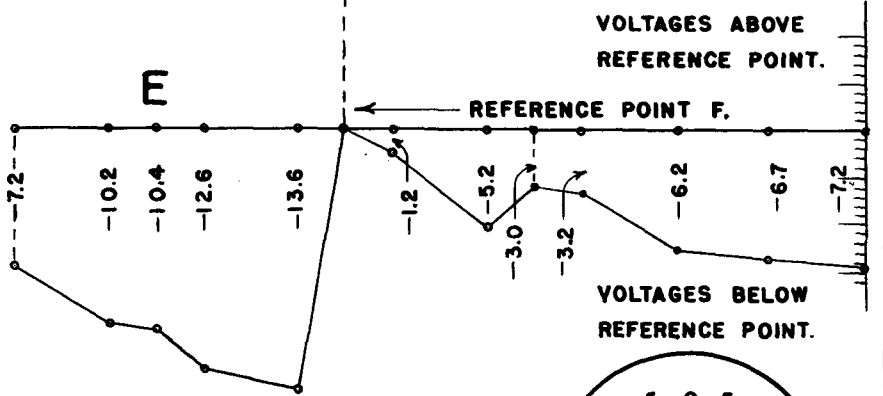
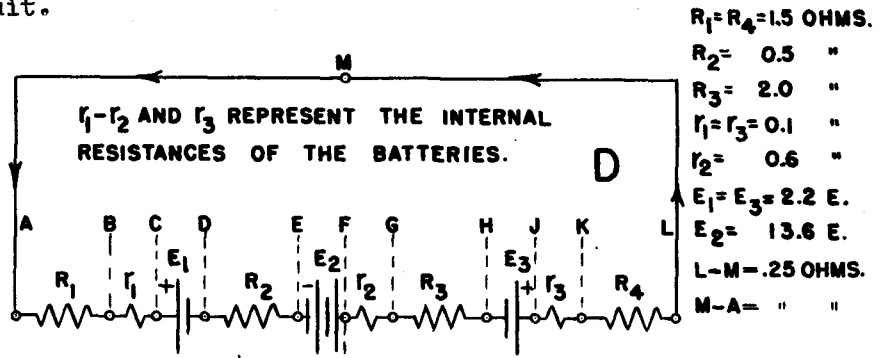

CIRCUIT TRACING AND TESTING ON BATTERY RECEIVERS

Determine Filament Polarities by the following facts:

- 1 - Grid return of all R.F. tubes always connect to "A" negative, "C" negative or contact arm of a potentiometer.
- 2 - Grid return of detector tube usually connects to "A" positive.
- 3 - Grid return of all A. F. tubes always connect to "A" negative or "C" negative.
- 4 - "C" positive always connects to "A" negative.

METHODS OF CONTROLLING VOLUME

A potentiometer has three contacts and should not be less than 175 ohms, and is used to control volume by varying the grid voltage.

A rheostat is used to control volume by varying the filament voltage.

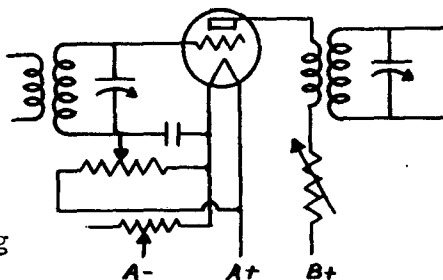

A 100,000 to 500,000 ohms variable resistor in series with the plate circuit is used to control volume by varying the plate voltage.

Note: Any one receiver utilizes one method of control

CONTINUITY METER CIRCUIT

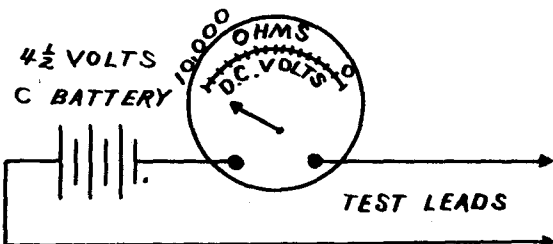

TABLE FOR SHORT TEST

Before taking any tests be sure that the switch and rheostats are closed.

"A" pos. to "A" neg. post	"B" pos. 45 to "A" pos. and "A" neg. posts	"B" pos. 90 to "A" pos. and "A" neg. posts

After taking short tests and before taking continuity tests, short "A" pos. and "A" neg. posts on receiver.

To obtain second reading on grid circuit of detector, short grid cond.

To obtain second reading on plate of last A.F. tube, short out the head-phone terminals.

TABLE FOR CONTINUITY TEST

Ant. to Gnd.	Location of Tube	F Pos. to F neg. prong	Grid prong to F prong	Plate prong to B+ post
	1st R.F.			B+90
	2nd R.F.			B+90
	Detector			B+45
	1st. A.F.			B+90
	2nd A.F.			B+90

LOCALIZING TROUBLE

- 1 - Test for battery voltage with headphones.
- 2 - Listen for click when phones are plugged into the plate circuit of the last A.F. tube.
- 3 - With the phones connected in the plate circuit of the last A.F. tube, touch the detector grid terminal. If a click or buzz is heard, the trouble is in the R.F. Amplifier. If no click or buzz is heard the trouble is in the A.F. Amplifier.

TROUBLES IN R. F. AMPLIFIER

- 1 - With phones connected in last A.F. plate circuit, disconnect the antenna lead-in wire and touch it to plate terminal of last R.F. tube and try to tune in a station. If signal is heard, repeat this test on next to last R.F. tube.

TROUBLES IN A. F. AMPLIFIER

- 1 - Connect the phone cord tips across the primary or secondary of the first A.F. transformer. Touch detector grid terminal and listen for click or buzz. If response is heard repeat this test on the second A.F. transformer and so on until the defective circuit is located.

VOLT OHM MILLIAMMETER.

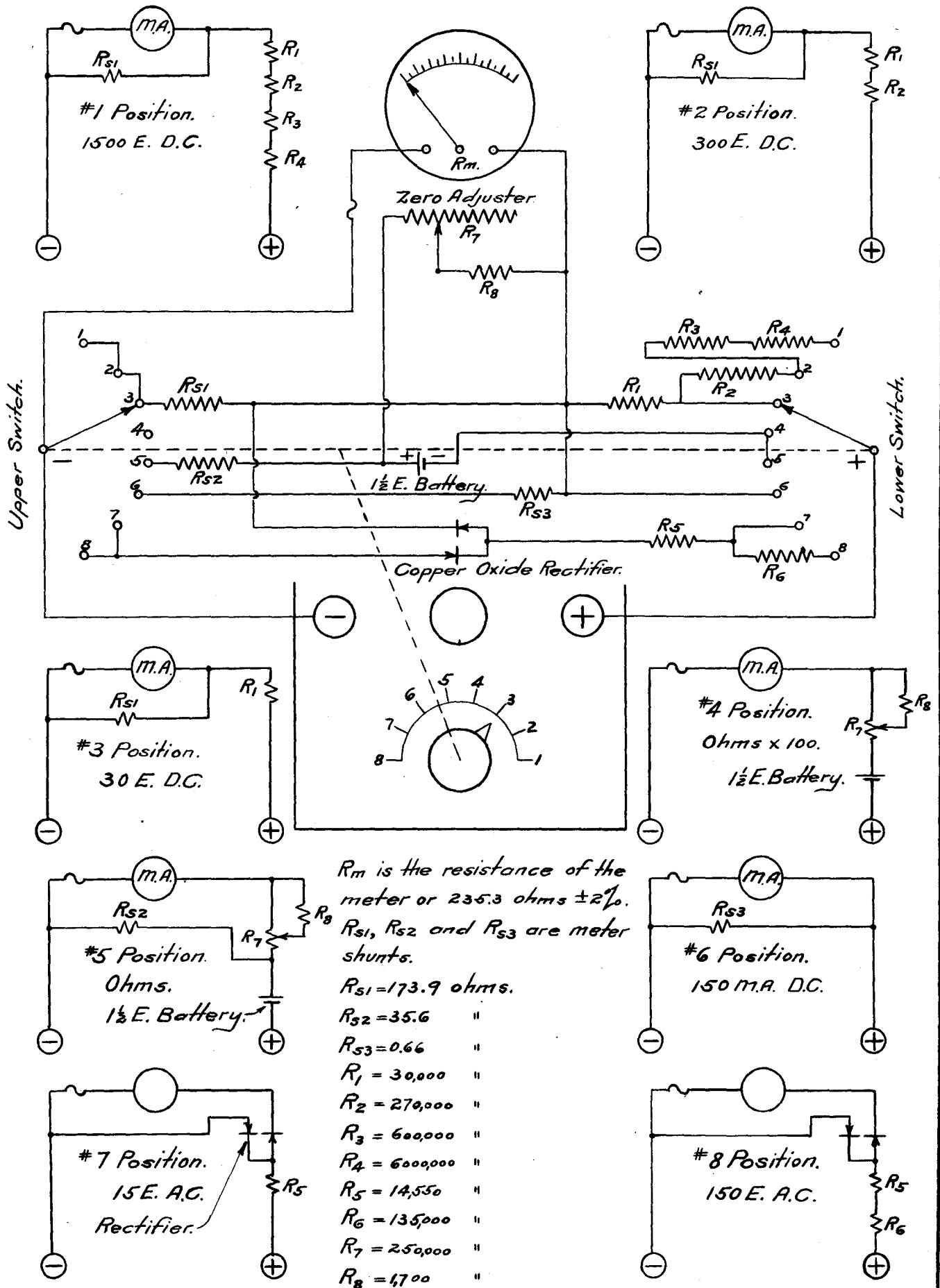

R_m is the resistance of the meter or 235.3 ohms $\pm 2\%$.
 R_{s1}, R_{s2} and R_{s3} are meter shunts.

$R_{s1} = 173.9$ ohms.
 $R_{s2} = 35.6$ "
 $R_{s3} = 0.66$ "
 $R_1 = 30,000$ "
 $R_2 = 270,000$ "
 $R_3 = 600,000$ "
 $R_4 = 6,000,000$ "
 $R_5 = 14,550$ "
 $R_6 = 135,000$ "
 $R_7 = 250,000$ "
 $R_8 = 1,700$ "

RESISTOR COMBINATIONS.

Series Resistors.

$$R_T = R_1 + R_2 + R_3 \dots$$

Parallel Resistors.

$$R_T = \frac{1}{\frac{1}{R_1} + \frac{1}{R_2} + \frac{1}{R_3} \dots}$$

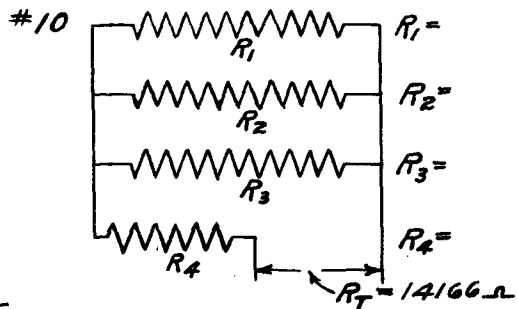
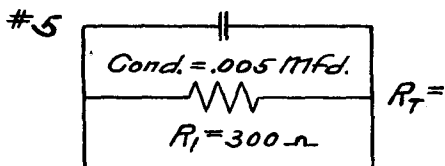
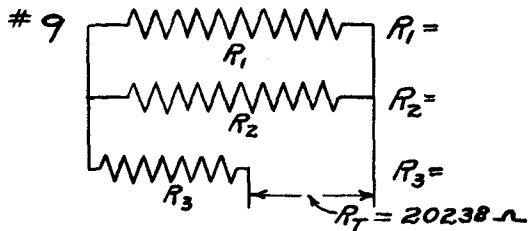
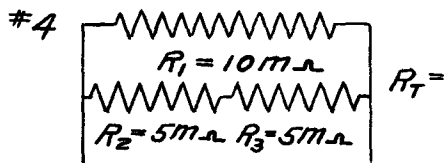
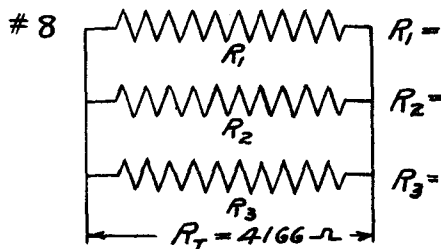
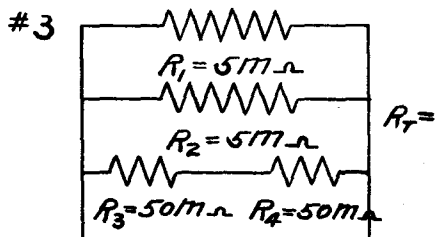
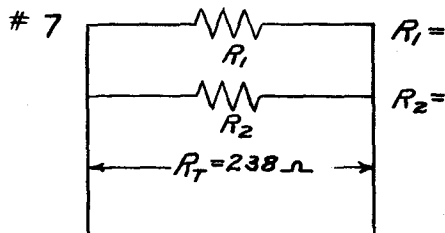
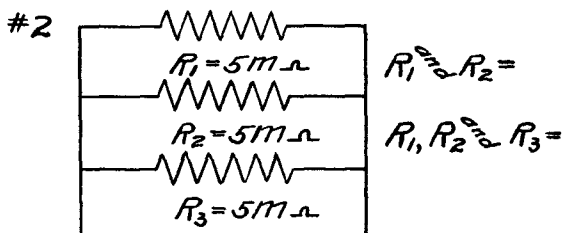
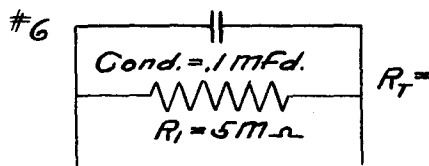
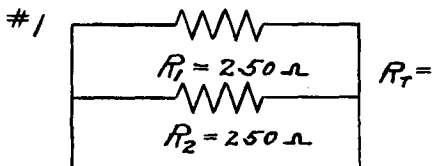

Solder all connections. Do not twist wires together when soldering. Bring diagram, job and meter to instructor for checking. Each job must be checked and approved. Job card will be punched when all 10 jobs have been approved by the instructor. When measured with an ohmmeter (D.C.) what effect on R_T does the condenser have? -----

RESISTANCE TEST OF RECEIVER CIRCUITS.

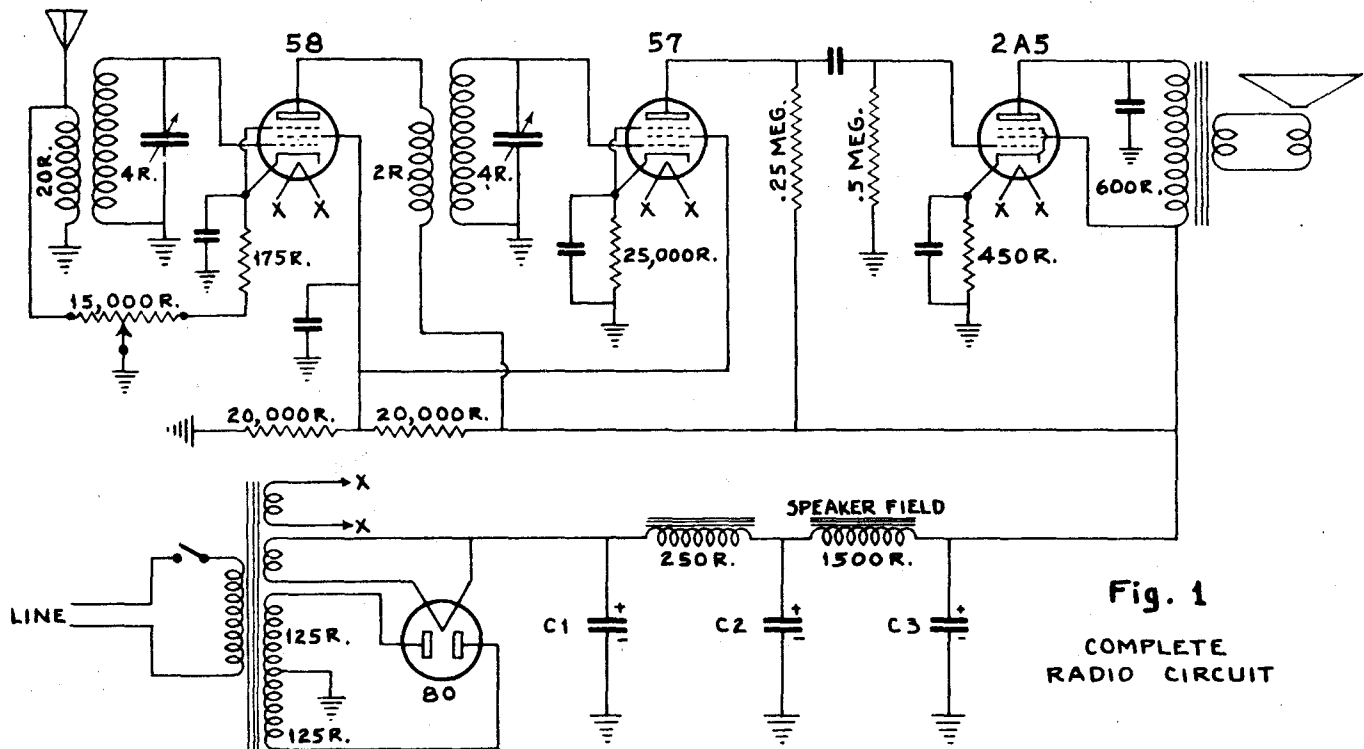
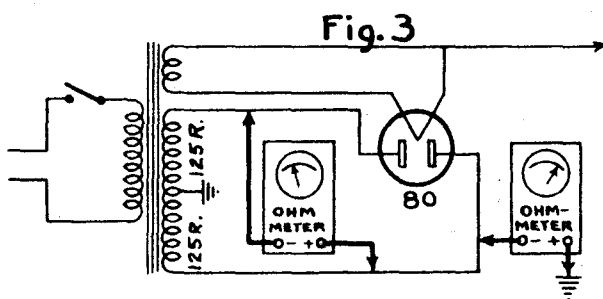
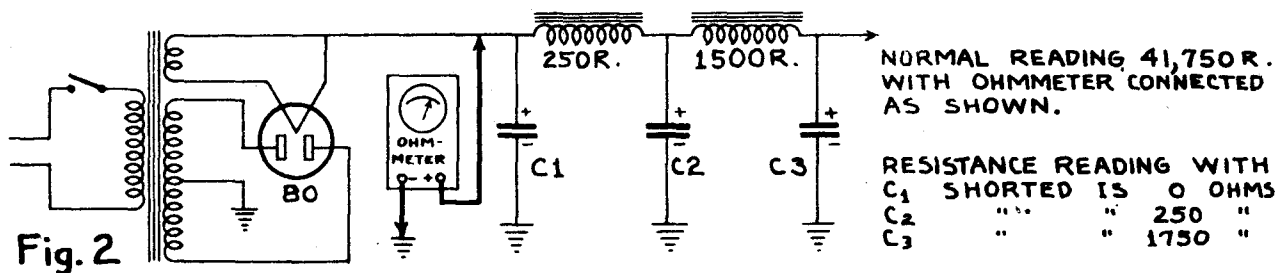
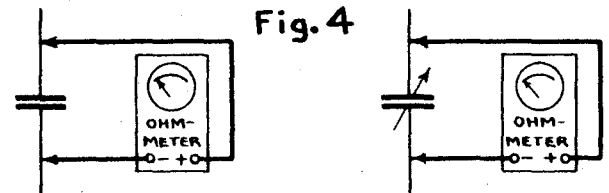

Fig. 1
COMPLETE
RADIO CIRCUIT

RECEIVER SHOULD NOT BE TURNED ON WHEN MAKING RESISTANCE TESTS. LOW RESISTANCE CIRCUITS SHOULD BE TESTED WITH THE METER'S LOW OHMMETER RANGE FOR MORE ACCURATE RESULTS. HIGH RESISTANCE CIRCUITS SHOULD BE TESTED WITH THE METER'S HIGH OHMMETER RANGE. POLARITIES OF ELECTROLYTIC CONDENSERS MUST BE OBSERVED. THE POSITIVE LEAD OF THE OHMMETER CONNECTS TO THE POSITIVE TERMINAL OF THE COND. AND THE NEGATIVE LEAD TO THE NEG. TERMINAL.



RESISTANCE FROM PLATE TO
PLATE APPROX. 250 OHMS
RESISTANCE FROM PLATE TO
GROUND APPROX. 125 OHMS.



SHORTED CONDENSER ZERO OHMS
OPEN CONDENSER NO READING
LEAKY CONDENSER GIVES A READING
DEPENDING ON THE AMOUNT OF LEAKAGE
GOOD COND. GENERALLY GIVES A MOMENTARY
DEFLECTION ON THE OHMMETER.
WHEN TESTING VARIABLE CONDENSERS
ROTATE THE ROTOR OR ADJUST TRIMMERS.

NOTE:- IF THE RESISTANCE OF A RESISTOR IS NOT WITHIN TEN PERCENT PLUS OR MINUS (10% ±) OF ITS RATED VALUE ONE END SHOULD BE DISCONNECTED AND ANOTHER TEST MADE.

RESISTANCE TEST OF RECEIVER CIRCUITS CONTINUED

Fig. 5

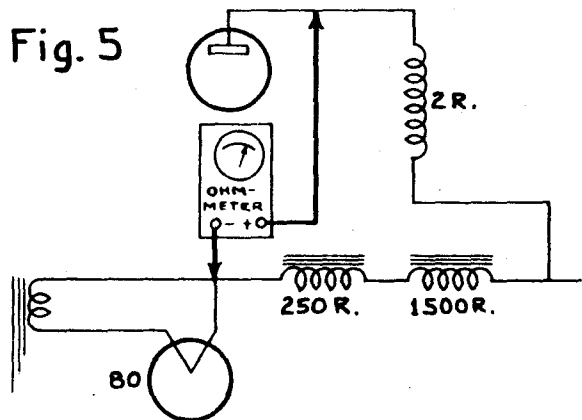

TESTING THE PLATE CIRCUIT. RESISTANCE READINGS SHOULD BE 1752 OHMS. NO READING INDICATES AN OPEN CIRCUIT.

Fig. 6

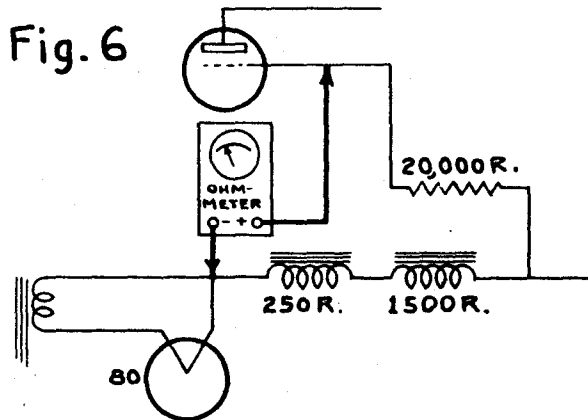

TESTING THE S.G. CIRCUIT. RESISTANCE READINGS SHOULD BE 21,750 OHMS. NO READING INDICATES AN OPEN CIRCUIT.

Fig. 7

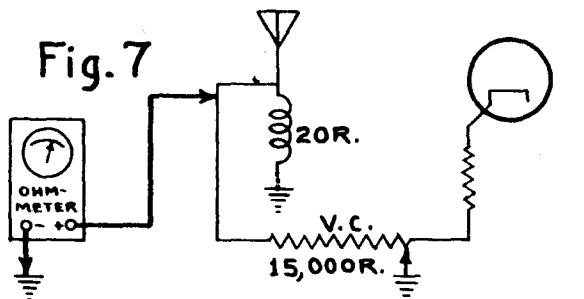

RESISTANCE TEST OF ANT. COIL. V.C. TO THE RIGHT READING IS 20 R. V.C. TO THE LEFT READING IS ZERO R.

Fig. 8

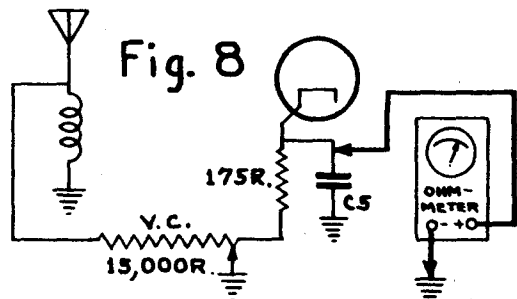

RES. TEST OF CATHODE CIR. WITH V.C. V.C. TO THE LEFT READING IS 15,175 R. V.C. TO THE RIGHT READING IS 175 R. COND. C5 SHORTED THE READING IS ZERO R.

Fig. 9

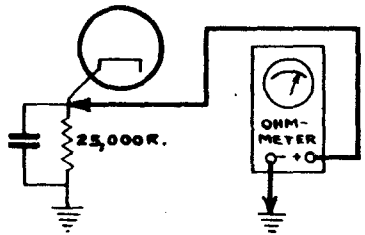

RESISTANCE TEST OF CATHODE CIRCUIT NORMAL READING IS 25,000 OHMS. OPEN RESISTOR IS NO READING. SHORTED CONDENSER IS ZERO OHMS.

Fig. 10

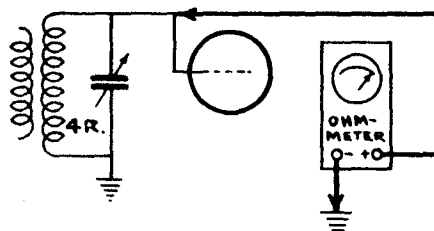

RESISTANCE TEST OF TUNED CIRCUIT NORMAL READING IS 4 OHMS. OPEN TRANSFORMER IS NO READING. SHORTED CONDENSER IS ZERO OHMS.

Fig. 11

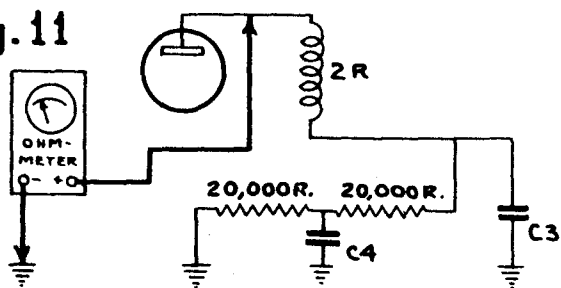

RESISTANCE TEST FROM PLATE TO GRD. NORMAL READING IS 40,000 OHMS. NO READING INDICATES AN OPEN CIR. 2 R. READING COND. C4 IS SHORTED. 20,000 R. READING COND. C4 IS OPEN.

Fig. 12

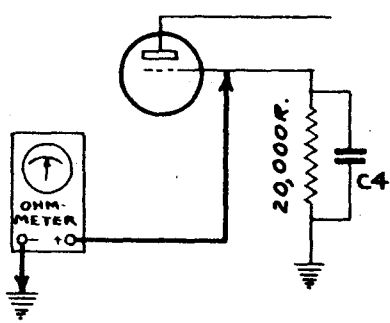

RES. TEST FROM S.G. TO GROUND. NORMAL READING 20,000 R. NO READING RESISTOR IS OPEN. ZERO OHMS COND. C4 IS SHORTED.

RECEIVER RESISTANCE ANALYSIS

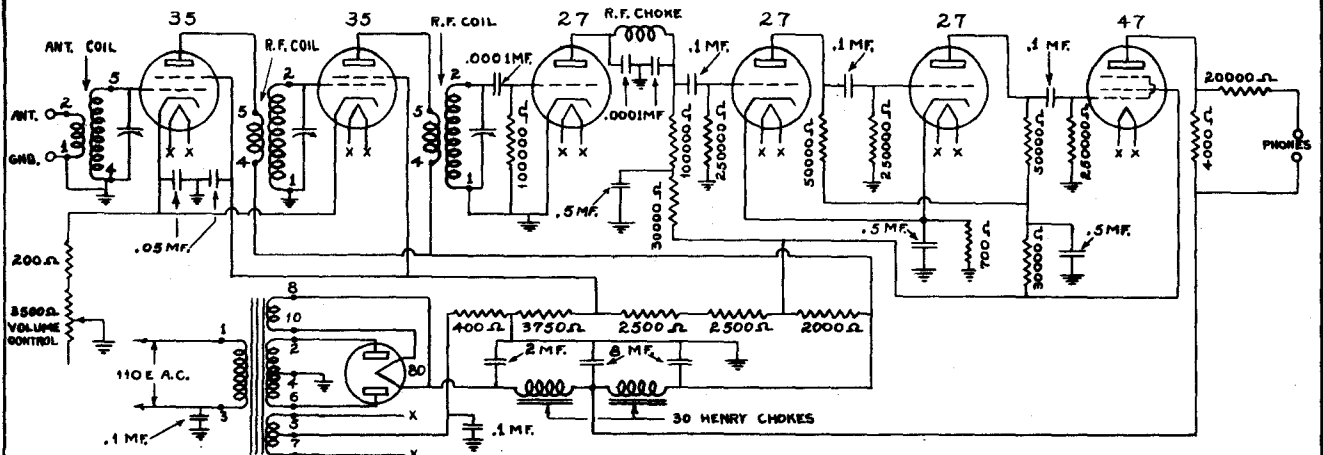

PARTS LAYOUT AND WIRING CONNECTIONS

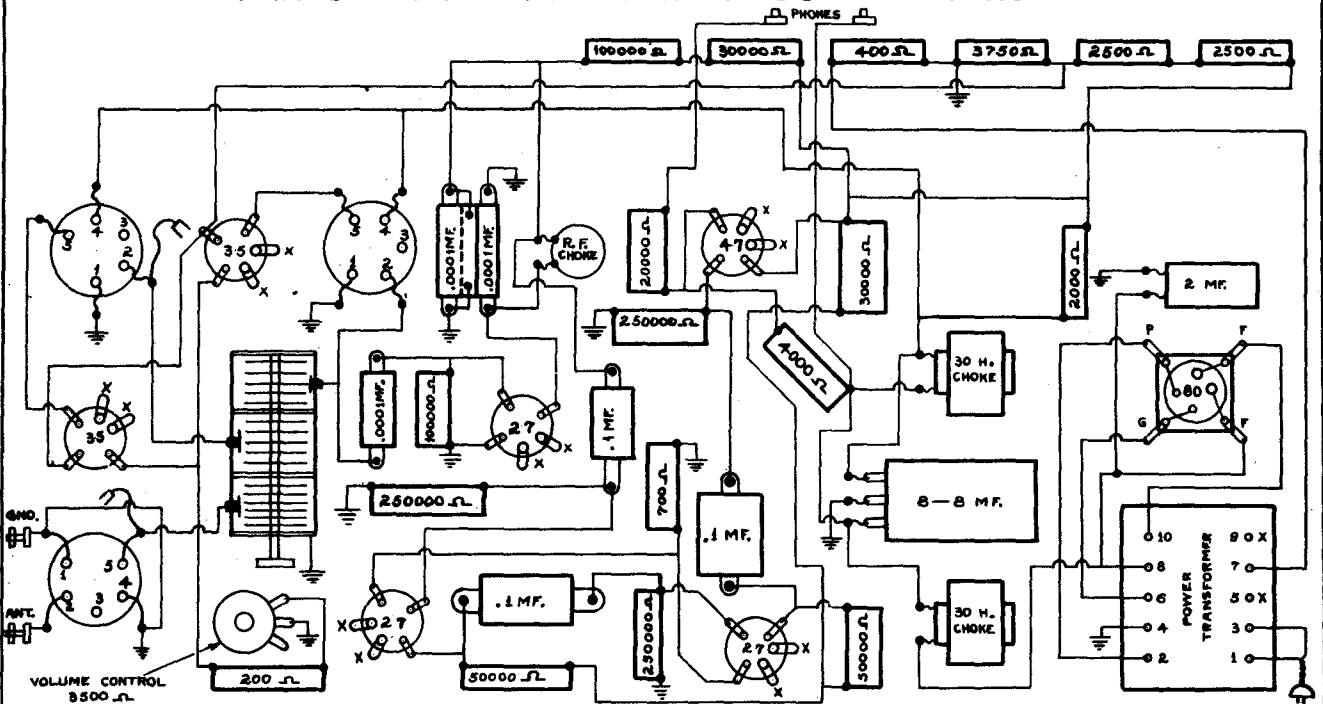

RESISTANCE CHART

STAGE	PLATE TO FILAMENT OF RECTIFIER	SCREEN GRID TO FILAMENT OF RECTIFIER	CONTROL GRID TO GROUND	CATHODE TO GROUND	PLATE TO GROUND	SCREEN GRID TO GROUND	HEATER TO HEATER
1 st R. F.				VOLUME OFF			
				VOLUME ON			
2 nd R. F.				VOLUME OFF			
				VOLUME ON			
DETECTOR		Grid				Grid	
1 st A. F.		Grid				Grid	
2 nd A. F.		Grid				Grid	
3 rd A. F.				FILAMENT TO GROUND			FILAMENT TO FILAMENT
				FILAMENT TO GROUND	P ₁	ANTENNA TO GROUND	FILAMENT TO FILAMENT
RECTIFIER	Grid	Grid	Grid	FILAMENT TO GROUND	P ₂		
	Grid	Grid	Grid				

R.M.A. COLOR CODE FOR RESISTORS AND CONDENSERS.

COLOR	FIGURE
Black	0
Brown	1
Red	2
Orange.	3
Yellow.	4
Green	5
Blue.	6
Violet.	7
Gray.	8
White	9

Color A gives first figure of resistance value.
 Color B gives second figure of value.
 Color C gives number of ciphers following the first two figures.
 Color D Gold band indicates 5% tolerance.
 Silver band 10% tolerance.
 No band 20% tolerance.

METHOD #1

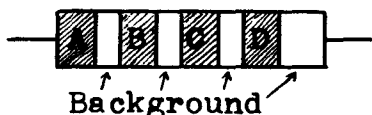

Color bands A, B, & C give resistance value.
 Color band D, usually omitted, indicates tolerance.
 Black background uninsulated.
 Brown background insulated.

EXAMPLE #1

<u>Band A</u>	<u>Band B</u>	<u>Band C</u>	<u>Band D</u>	<u>Background</u>	<u>Value</u>
Green-	Black-	Black-	None-	Black	50 ohms-20% Uninsulated.
Red-	Green-	Brown-	Silver-	Brown	250 Ohms-10% Insulated.
Green-	Black-	Yellow-	None-	Black	500M ohms-20% Uninsulated.
Orange-	Green-	Green-	Gold-	Brown	3.5 Meg.-5% Insualted.

METHOD #2

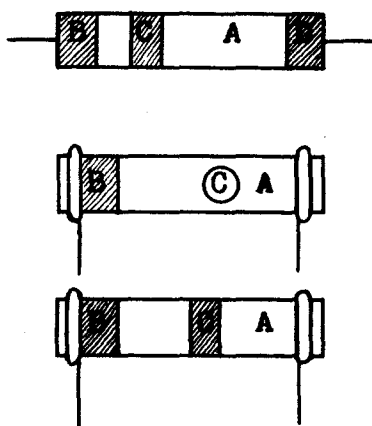

Body color A, end color B, and dot or band C gives value. Gold or silver band D, usually omitted, indicates per cent of tolerance.

EXAMPLE #2

<u>Body A</u>	<u>End B</u>	<u>Dot or band C</u>	<u>Value</u>
Green-	Black-	Black-	50 ohms
Red-	Green-	Brown-	250 ohms
Green-	Black-	Yellow-	500,000 (500M)
Orange-	Green-	Green-	3,500,000 (3.5 meg)

EXAMPLES OF MICA CONDENSERS

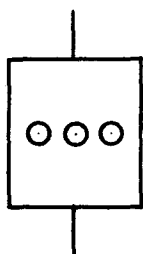

<u>1st Dot</u>	<u>2nd Dot</u>	<u>3rd Dot</u>	<u>Condenser value</u>
Green-	Black-	Black-	50 mmfd (.00005 mfd)
Brown-	Black-	Brown-	100 mmfd (.0001 mfd)
Red-	Green-	Brown-	250 mmfd (.00025 mfd)
Green-	Black-	Red-	5000 mmfd (.005 mfd)

CONDENSER TESTING.

Use Power Pack to Obtain D.C. Voltage.
(See preceding page.)

Basic Circuit for Trouble Testing on Paper & Mica Cond.

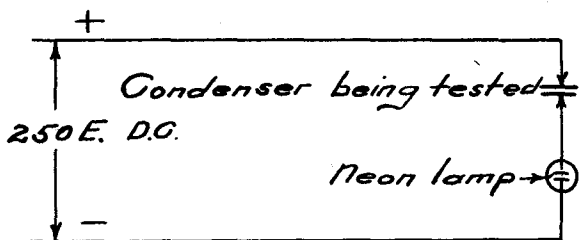

Troubles.

- 1- Open - Lamp does not flash.
- 2- Shorted - Continuous glow on lamp.
- 3- Leaky - Flicker. Lamp will flash less than once per second on a good condenser.

Circuit for measuring leakage on Electrolytic Condensers.

*Caution - Test for shorts with an ohmmeter before leakage test is made.
Do not test shorted condensers for leakage or meter will be*

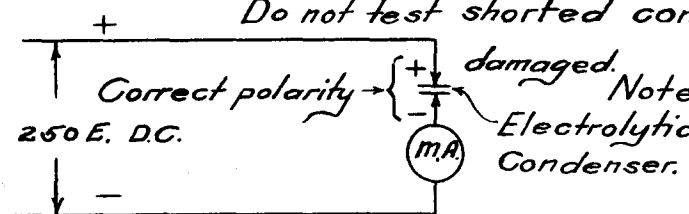

Note. - Leakage should be less than 1/4 m.A. per mfd. with 250 volts applied on a condenser rated at 450 volts.

Condenser Test Chart.

<i>Paper and mica.</i>		<i>Electrolytic Condensers.</i>			
<i>Size</i>	<i>Condition.</i>	<i>Size</i>	<i>Leakage.</i>		<i>Condition.</i>
			<i>Right Polarity</i>	<i>Wrong Polarity.</i>	

CONDENSER CAPACITY TEST.

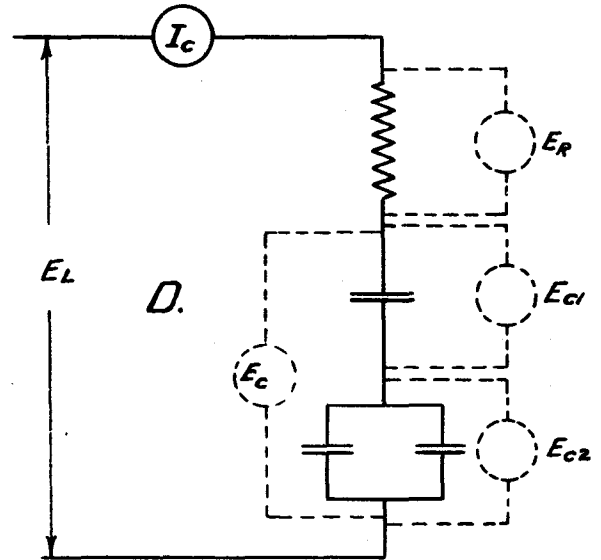
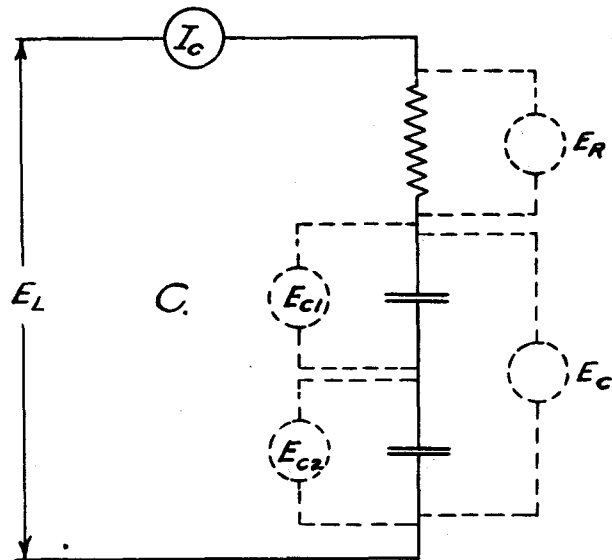
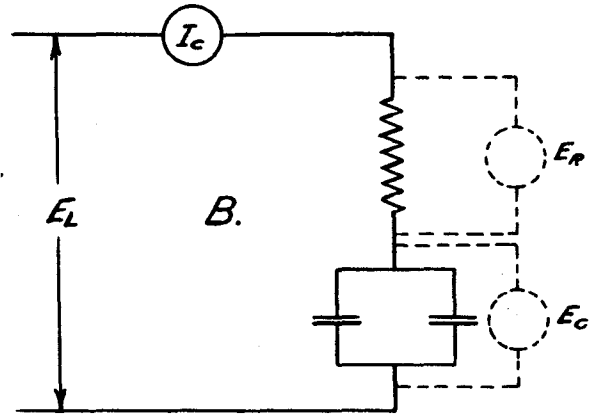
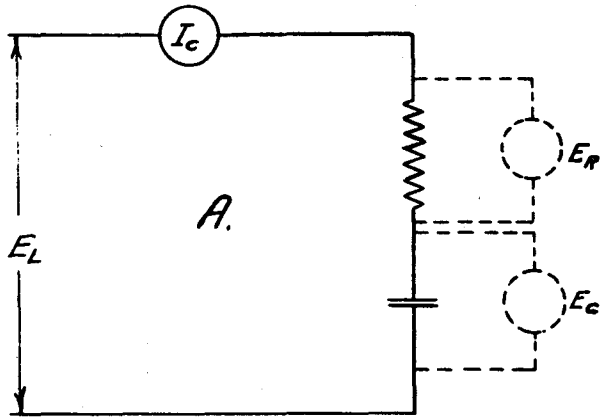

	$I = \frac{E_R}{R}$	E_R	$X_C = \frac{E_C}{I}$	E_C	Cap. mfd.	$E_R + E_C$	$\sqrt{E_R^2 + E_C^2}$	E. Line	E_{C1}	E_{C2}	$Z = \frac{E_L}{I}$
A											
B											
C											
D											

Adding the voltage drop across the resistor (E_R) to the voltage drop across the condenser (E_C) will not give a value equal to the applied voltage because these two voltage drops are not in phase with each other. To find the resultant voltage the quantities must be added thus

$$E_L = \sqrt{E_R^2 + E_C^2}$$

CONDENSER TESTER

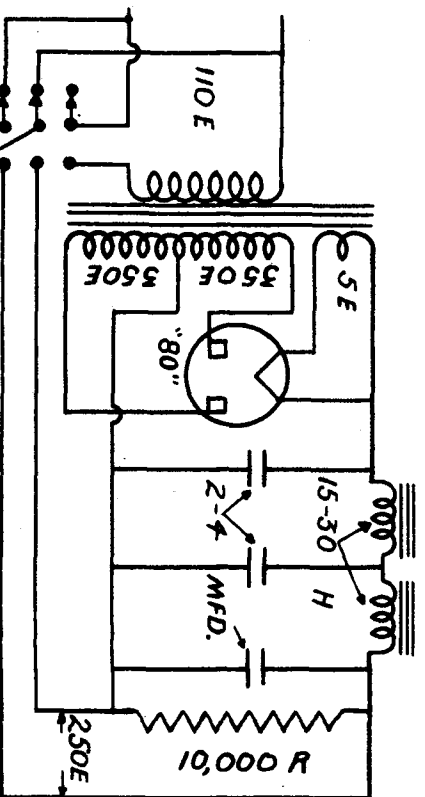

ELECTROLYTIC CONDENSER

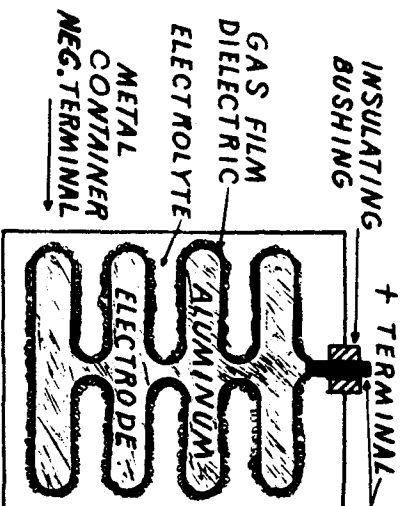

tone CONTROLS

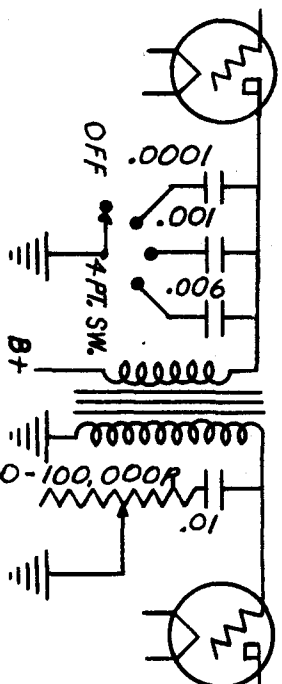

SPEAKERS

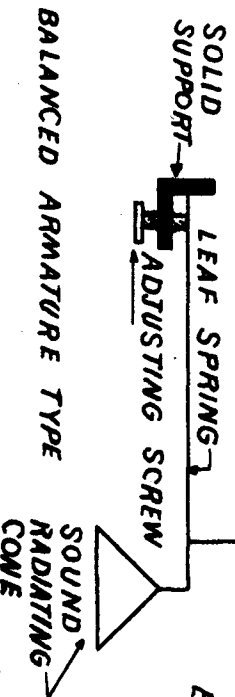
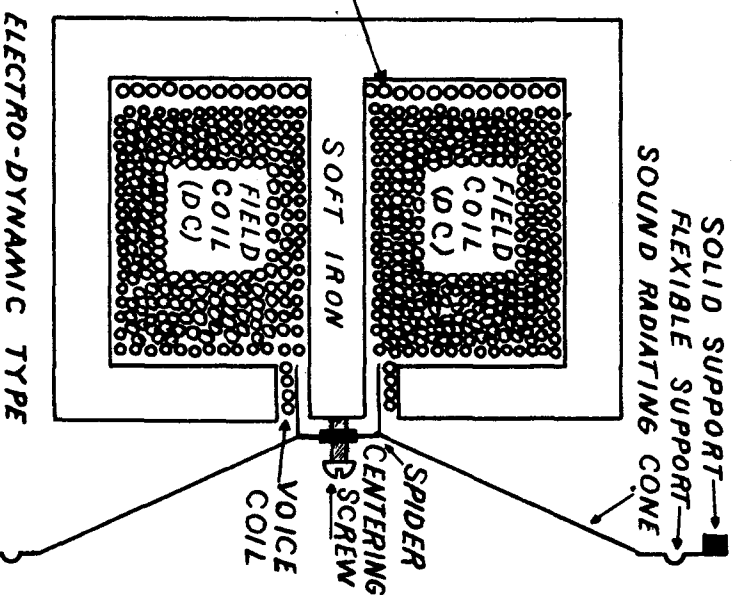
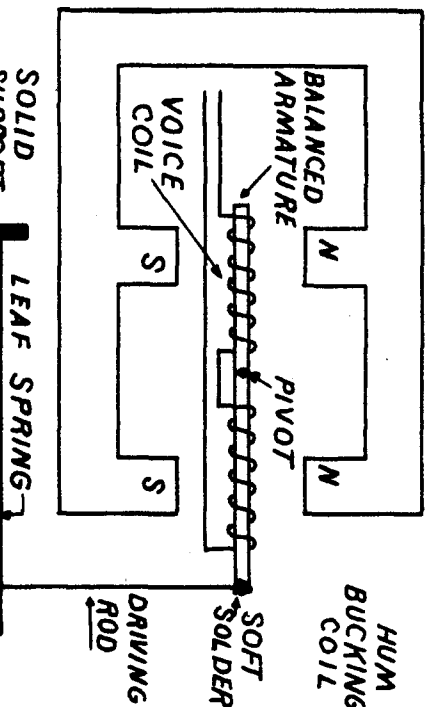
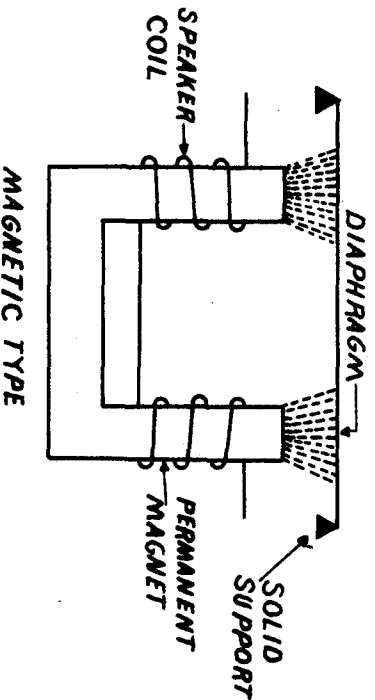

TROUBLE SHOOTING WITH AN ANALYZER.

THIS CHART APPLIES TO TESTS MADE USING THE CATHODE OR FILAMENT AS A COMMON. IF GROUND (GENERALLY THE CHASSIS) IS USED AS A COMMON, NUMBERS 3, 6 AND 15 WILL NOT APPLY. USE 3A, 6A AND 15A ON THE RIGHT SIDE OF CHART.

	1	2	3	4	5	6	7	8	9	10	11	12	13	14	15	16				
	OPEN GRID OR CONTROL GRID OR SHORTED GRID BY-PASS CAPACITOR.		OPEN GRID BIAS RESISTOR.	OPEN PLATE CIRCUIT.	OPEN SCREEN GRID CIRCUIT.	UNGROUNDDED HEATER CIRCUIT.	BURNED OUT TUBE.	OPEN FILAMENT OR HEATER CIRCUIT.	SHORTED SCREEN GRID BY-PASS CAPACITOR.	SHORTED COUPLING CONDENSER.	OPEN PLATE RESISTOR.	RECTIFIER.	WEAK RECTIFIER TUBE.	HIGH RESISTANCE IN B+ OR B-	OPEN B+ OR B- SHORTED B+ OR B-	SHORTED FILTER CONDENSER.				
															3A	6A	15A			
I_p	H	H	O	O	F_{20}	N	O	O	O	H	O	N_H	I_{T1}	L	L	O	H	O	N	O
E_p	L	L	O	O	H	N	H	H	L	L	O	N_H	I_{P2}	L	L	O	H	H	N	O
E_{g1}	L	L	O	H	O	N	H	H	F_{20}	L	O	H	E_{P1}	H	H	O	L	H	N	O
E_{g2}	O	O	V.H.	F_{20}	F_{20}	N	F_{20}	F_{20}	F_{20}	H	F_{20}	N	E_{P2}	H	H	O	L	O	O	O
E_k	H	O	V.H.	F_{20}	F_{20}	O	F_{20}	F_{20}	F_{20}	H	F_{20}	N	N_H					V.H.	N	
E_f	N	N	N	N	N	N	H	O	N	N	N	N_H	E_f	N	N	N	N	N	N	N
E_b	N	N	N	N	N	N	H	O	N	N	N	E_f	E_f	N	N	N	N	N	N	N

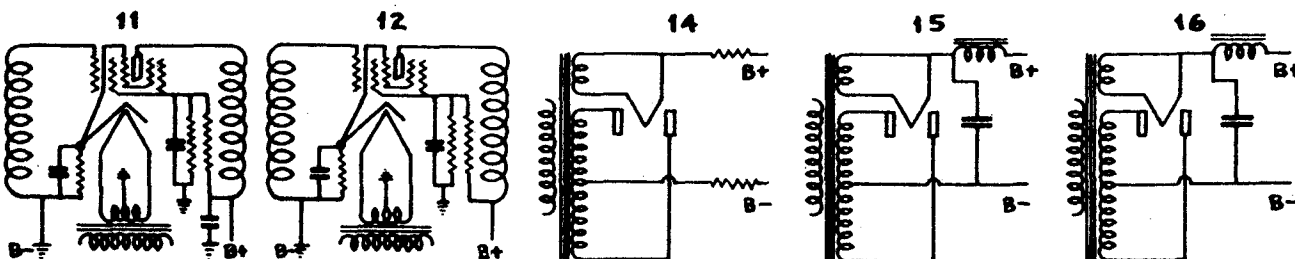
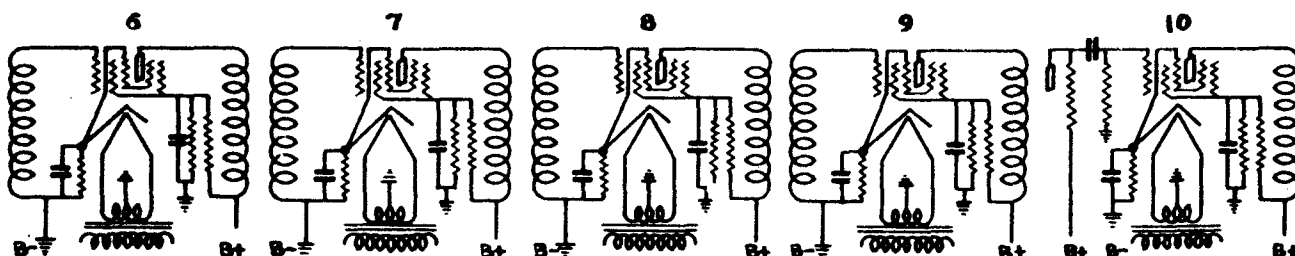
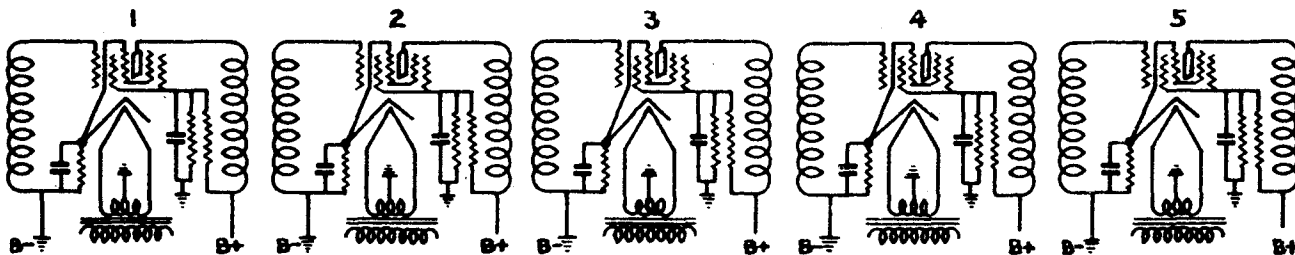

ALIGNING SUPERHETERODYNE RECEIVERS.

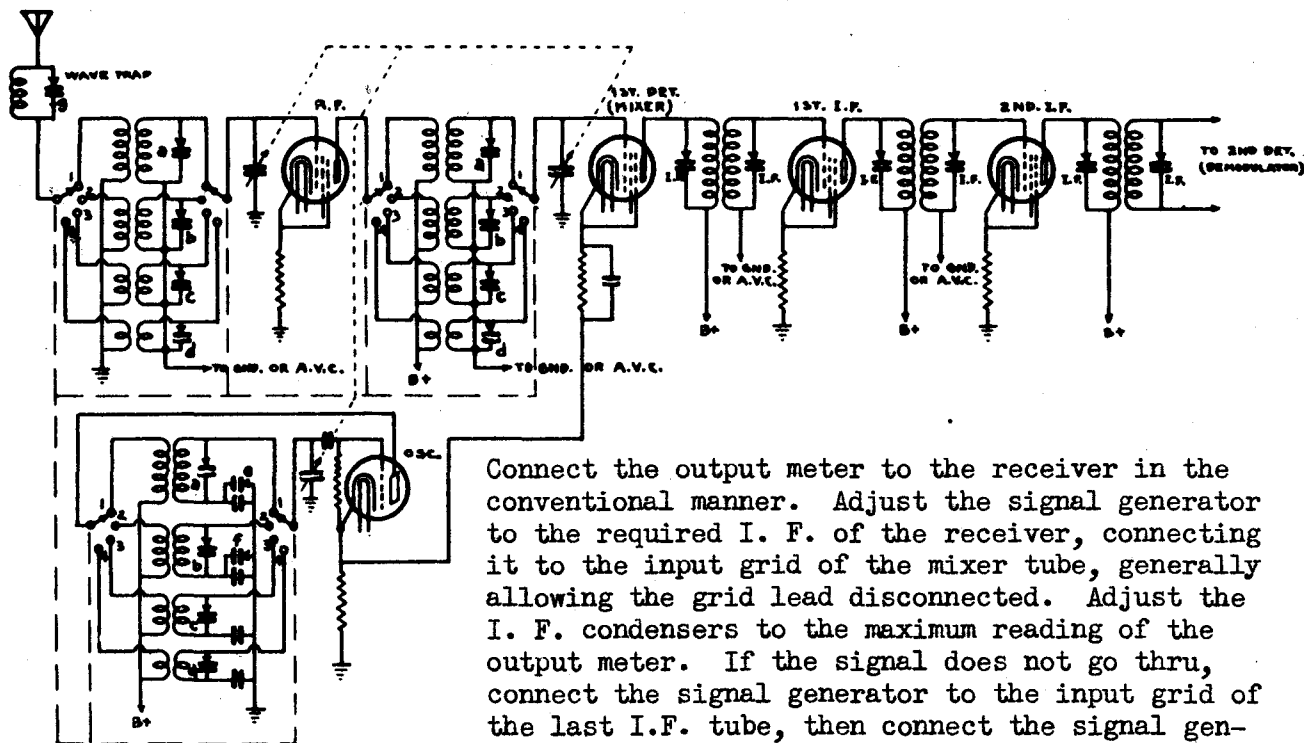

Connect the output meter to the receiver in the conventional manner. Adjust the signal generator to the required I. F. of the receiver, connecting it to the input grid of the mixer tube, generally allowing the grid lead disconnected. Adjust the I. F. condensers to the maximum reading of the output meter. If the signal does not go thru, connect the signal generator to the input grid of the last I.F. tube, then connect the signal generator to the preceding stages.

Transfer the signal generator connections to the antenna and ground of the receiver.

Tune the receiver to band #1 (generally the broadcast band). If the receiver has a wave trap, the trimmer (g) is adjusted to minimum reading of the output meter, when the signal generator is tuned to the I. F. and the tuning condensers are tuned to the low frequency end of the broadcast band.

Adjust the signal generator and the receiver to 1400 k.c. Adjust the high frequency trimmers (a) to maximum reading of the output meter.

Adjust the signal generator and the receiver to 600 k.c. Adjust the low frequency trimmer (e) to maximum reading of the output meter.

Tune the receiver to band #2 (generally the first short wave band)

Adjust the signal generator and the receiver to the required frequency of band #2. Adjust the high frequency trimmers (b) to the maximum reading of the output meter.

Adjust the signal generator and the receiver to the required low frequency and adjust the low frequency trimmer to the maximum reading of the output meter.

The same procedure is followed with bands #3 and #4, the high frequency trimmers (c) and (d) are adjusted for maximum reading of the output meter in their respective bands.

NOTE: Keep output of the signal generator low in value, allowing just enough signal to give a readable induction on the output meter. Above frequencies do not apply to all receivers, check with manufacturers aligning data.

METHODS OF CONNECTING OUTPUT METERS

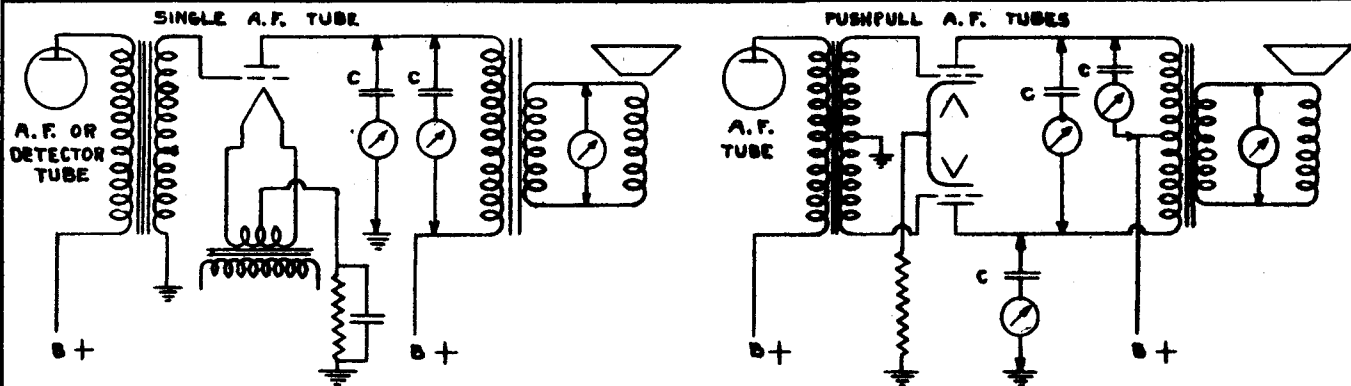

The drawings above show seven of the most popular methods of connecting an output meter to a single A.F. or push-pull A.F. stage. Only one of the above methods is necessary for an aligning indicator. The condenser "C" may be any capacity from .1 mfd. on up, with a voltage rating of 400 volts or more. Meters used as output meters, in above connections, may be conventional output meters or A.C. meters having a range of 0 to 5 milliamperes or less.

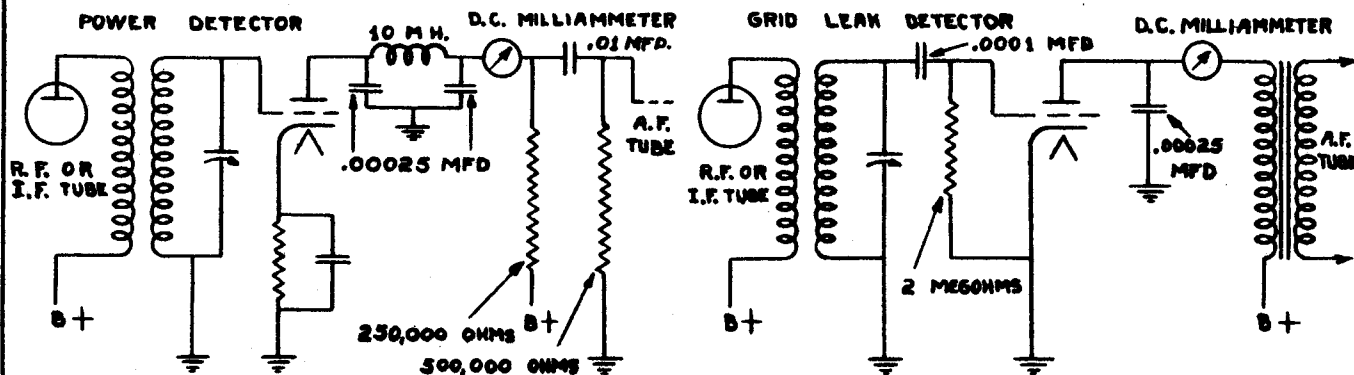

A.D.C. milliammeter may also be used as an output meter by connecting it in series with the plate circuit of the detector stages. In the power detector, the milliammeter is adjusted for the highest reading, and in the grid leak detector to the lowest reading, when adjusting the trimmer condensers of the I.F., oscillator, mixer, and R.F. stages, (with the exception of the wave trap.) If this connection is used, it is important to keep meter leads short to prevent unstable readings.

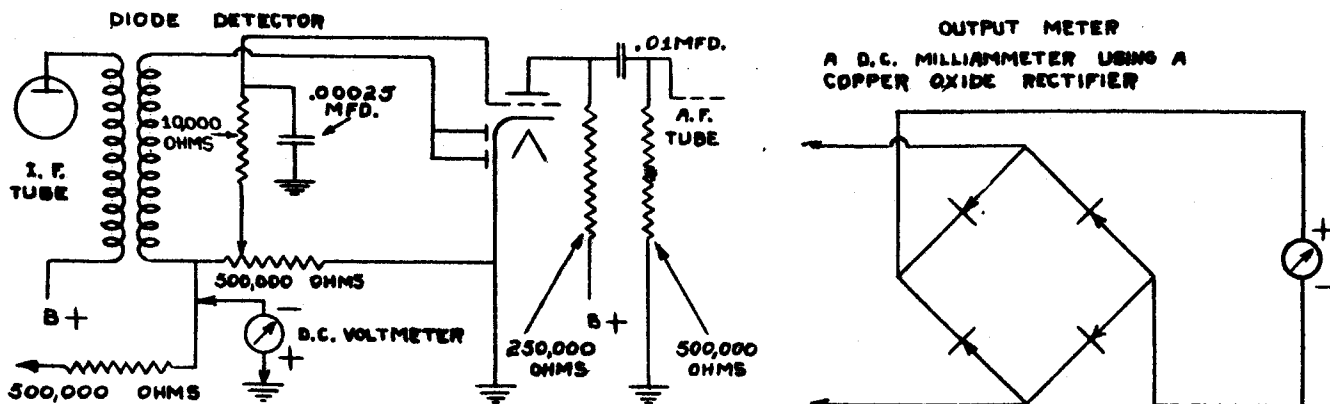

Circuits that employ A.V.C. can have a high resistance D.C. voltmeter connected across the load resistor of the diode detector. The positive side of the voltmeter is connected to the grounded end of the resistor and the negative to the negative end of the load resistor. The meter connections at the top of the sheet may also be used.

OSCILLOGRAPH

CATHODE RAY TUBE

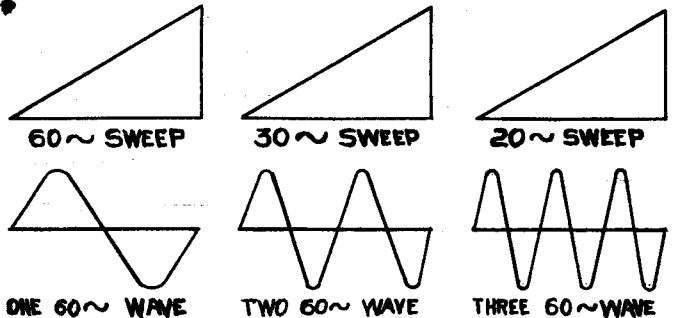
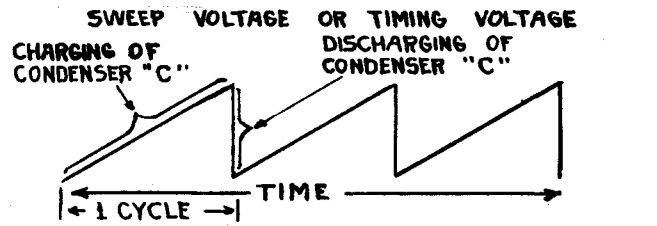
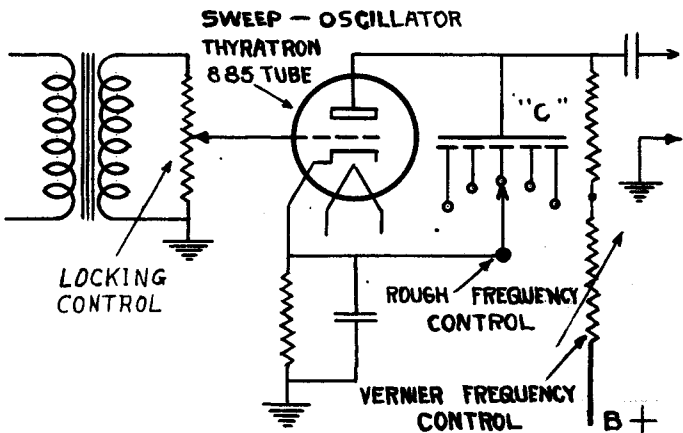
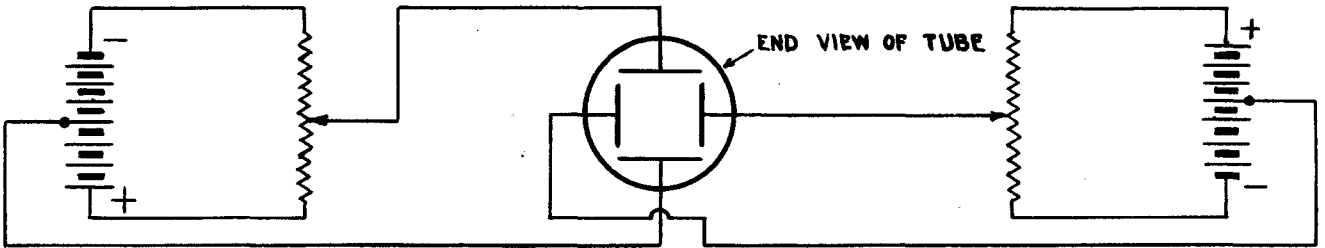
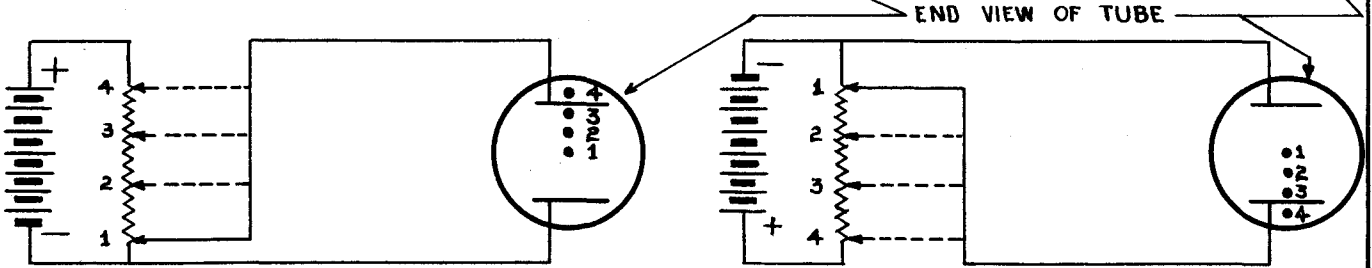
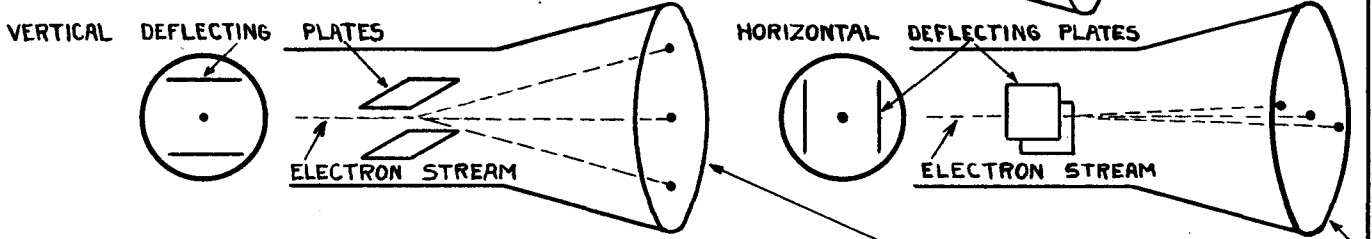
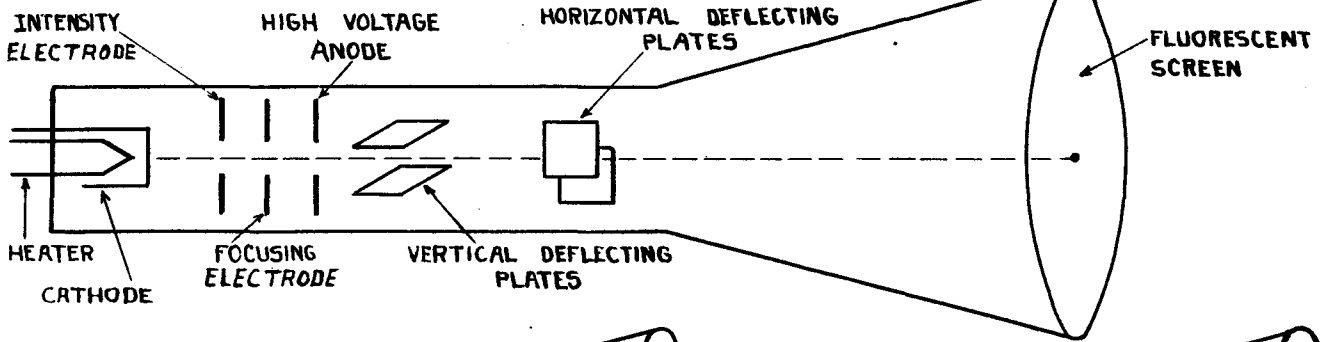

DETERMINING THE SENSITIVITY OF THE CATHODE RAY TUBE

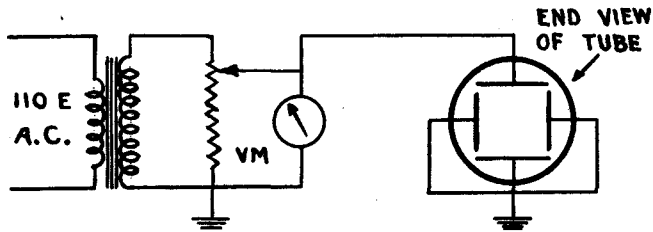

DETERMINING THE GAIN OF AN AMPLIFIER

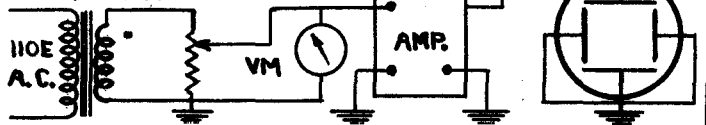

OSCILLOGRAPH CONNECTIONS TO THE DEMODULATOR TUBE WHEN ALIGNING A RECEIVER

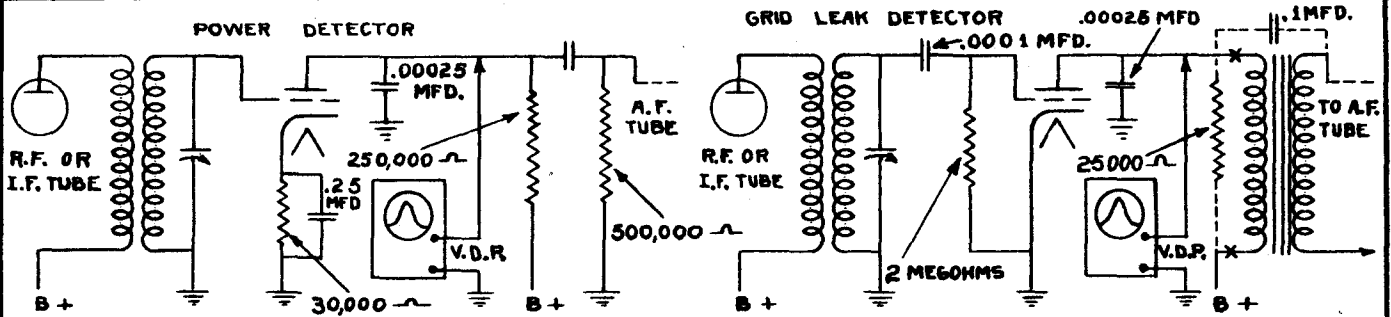

In case of a power detector and a grid leak detector, the binding posts of the vertical deflecting plates (V.D.P.) are connected to plate and ground. The ungrounded post to the plate and the remaining post to ground. Sets, employing transformer or impedance coupling between the detector and the first A.F. tube, should have the reactive unit disconnected from the plate and connect a 25,000 ohm resistor in place of it as shown. The purpose of this change is to prevent distortion of the waveform. Then connect a .1 mfd. condenser between the plate and grid to couple the two circuits.

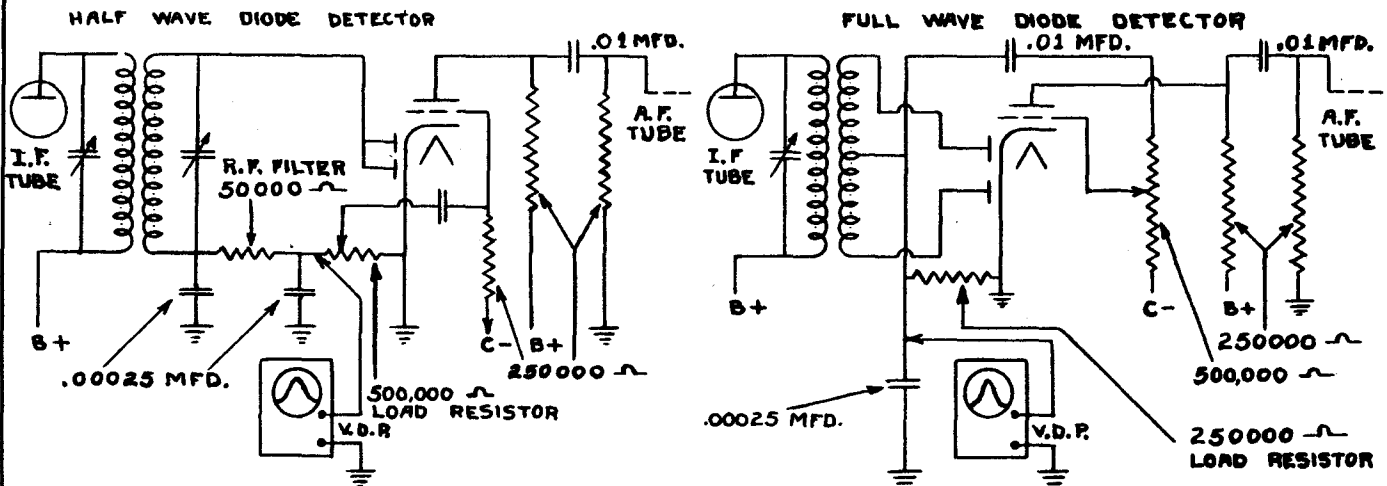

Receivers employing diode detection must have the V.D.P. of the oscilloscope connected across the load resistor of the diode detector. Connect the ungrounded V.D.P. to the negative or ungrounded end of the load resistor and the grounded V.D.P. to ground.

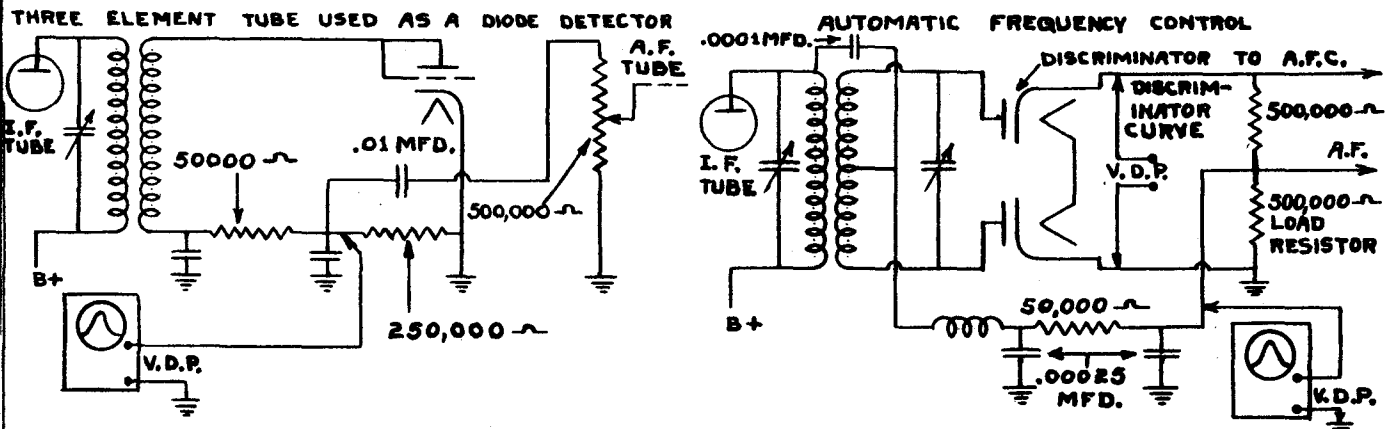

In A.F.C. circuits the V.D.P. binding posts of the oscilloscope are connected across the load resistor that connects to a ground. The connections of the V.D.P. to the load resistor are the same as mentioned above. To obtain the discriminator curve, connect the V.D.P. across both load resistors or from cathode to cathode of the dis-

EMERGENCY METHOD OF ALIGNING A RECEIVER WITHOUT A SIGNAL GENERATOR:

Although a signal generator is ordinarily required for the alignment of a receiver, it is not absolutely essential. When a situation arises in which such an instrument is not available, the procedure outlined below may be employed. The ultimate alignment will not be as good as that obtained with a signal generator, but the set will work, and satisfactory reception will be possible. The possibility of such an emergency makes a knowledge of the subsequent material of vital importance.

A. Substitutes for a Signal Generator

1. Any broadcast or short wave station.
2. Any modulated radio signal such as may be obtained from portable or stationary transmitters.
3. Disturbance signal introduced by tapping the grid of the mixer tube with a moistened finger.
4. Any other source of modulated RF energy such as may be produced by ignition systems, X-ray apparatus, vibrating spark coils, etc.,
5. If an unmodulated RF signal is available, it may be modulated by introducing into an appropriate grid on the receiver an audio rate variation produced by a microphone, headset, phonograph pick-up, or a low voltage (10 volts or less) 60 cycle A.C. supply.

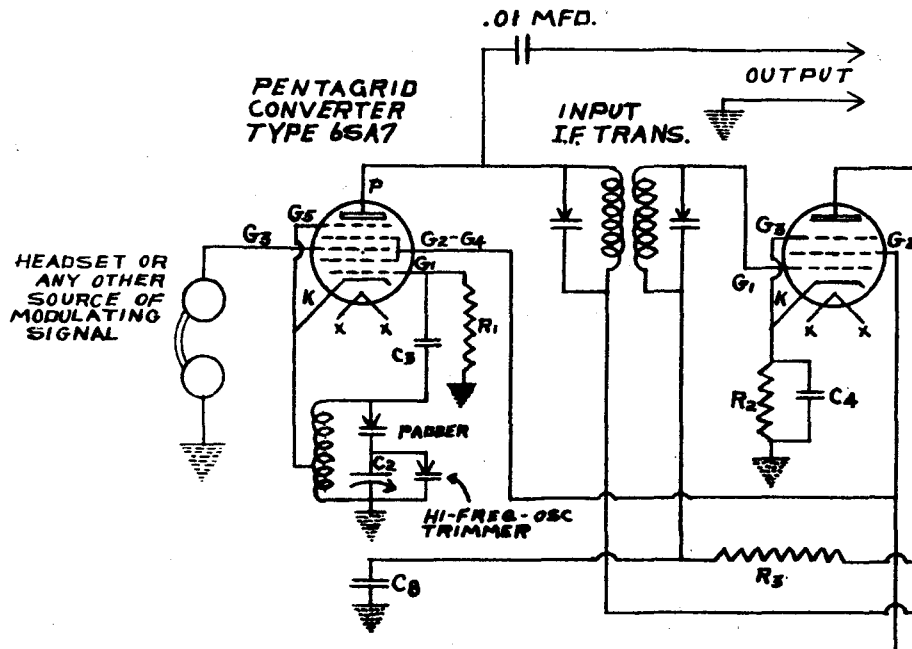

B. Procedure if Signal or Station can be Tuned in

1. Turn tuning condenser plates until maximum volume is obtained.
2. Adjust I.F. trimmers to maximum signal.
3. If the frequency of the received signal is known, check the dial reading. Turn tuning dial toward correct frequency while adjusting the high frequency trimmers and padder for maximum volume.
4. If tuning dial cannot be adjusted to correct frequency, adjust the I.F. trimmers to maximum volume while dial is being turned towards the correct frequency.
 - a. I.F. trimmer condensers should be fairly tight for correct adjustment.
 - b. If medium reception is obtained with the I.F. trimmer condenser screws turned almost all the way out, it indicates that the I.F. circuits are resonant to the harmonic of the correct I.F. Reception will not be at its best. Tighten trimmers and repeat B.

- C. Procedure if Signal Cannot be Heard.
1. Turn all I.F. trimmer condensers down fairly tight.
 2. Tap the R.F. input grid of the mixer tube with finger to produce a disturbance. Readjust I.F. trimmers to obtain maximum disturbance.
 3. Adjust high frequency trimmers and padder for maximum noise level.
 4. Tune in a signal or station and repeat all steps in procedure "B"
- D. After the Above Aligning Procedure is Completed.
1. Tune in a station of known frequency at the high frequency end of the dial and readjust high frequency trimmers to maximum volume at correct dial reading.
 2. Tune in a station of known frequency at the low frequency end of the dial and readjust padder for maximum volume at correct dial reading.
- E. Always use an Insulated Screw Driver to Adjust Trimmers and Padder.
1. One quarter inch diameter bakelite rod at least six inches long.
 2. One quarter inch diameter fibre rod at least six inches long.
 3. One quarter inch diameter hard maple wood rod.
 4. Any other similarly shaped piece of insulating material.

METHOD OF CHECKING THE CALIBRATION OF A SIGNAL GENERATOR

1. Tune in a station of known frequency on any radio receiver.
2. Feed signal from signal generator into the receiver antenna circuit, and set signal generator dial the same frequency as the received station.
3. Turn selector switch on signal generator to unmodulated R.F.
4. Rotate signal generator dial slowly back and forth across the correct frequency calibration.
 1. Whistle should be heard when the dial is turned to each side of the correct frequency. The pitch of the whistle should decrease as the dial approaches the correct frequency and disappear entirely when the dial is set accurately on the correct frequency. This indicates that the dial is calibrated accurately at this position. The calibration may be checked at any position where a station of known frequency may be tuned in on the receiver.

NOTE - The whistle referred to above is caused by the heterodyning of the received carrier with the signal produced by the signal generator. The pitch (frequency) of the whistle depends upon the difference between the two frequencies. When the signal generator produces a signal frequency equal to the carrier frequency, the difference is zero; therefore, a whistle will not exist. Adjusting the signal generator to a lower pitch until the whistle disappears is referred to as, "adjusting signal generator to zero beat note".

2. A check on signal generator frequencies below the broadcast frequency, such as are used for aligning the IF, may be obtained by using the first harmonic of the IF frequency. For example, if IF is 500 Kc, 1st harmonic is 1000 Kc.

ANALYZING - METER CONNECTIONS

USING CATHODE AS COMMON AS SHOWN IN DRAWINGS OR GROUND MAY BE USED AS COMMON FOR VOLTAGE ANALYSIS.

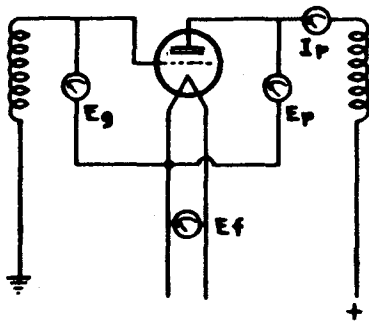

THREE ELEMENT FILAMENT
TYPE TUBE - 26, 45 ETC.

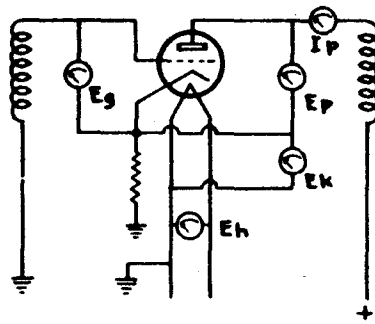

THREE ELEMENT HEATER
TYPE TUBE - 27, 56 ETC.

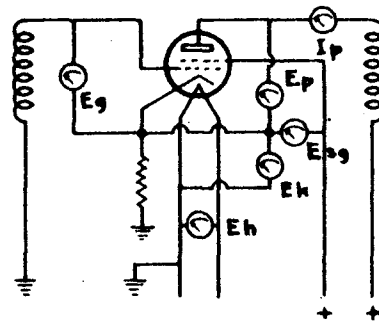

SCREEN GRID HEATER
TYPE TUBE - 24-35 ETC.

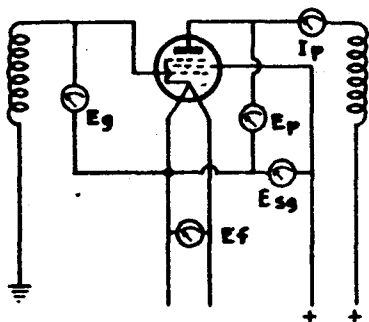

PENTODE FILAMENT TYPE
TUBE - 47, 33 ETC.

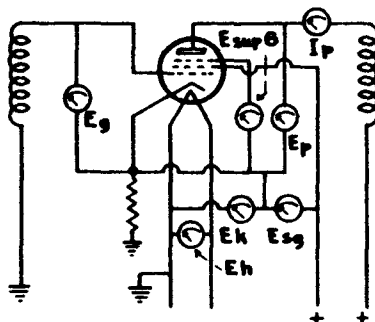

PENTODE HEATER TYPE
TUBE - 57, 58 ETC.

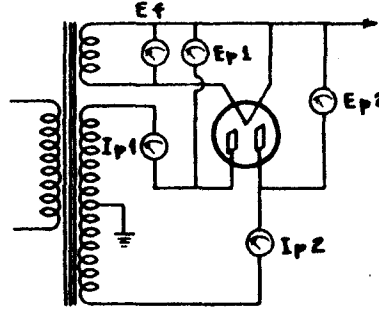

RECTIFIER FILAMENT
TYPE - 80, 523 ETC.

SYMBOLS

- Ip. - Plate current
- Ip. grid test - Plate current when making the grid test.
- Ep. - Plate volts.
- Esg. Screen grid volts.
- E sup. G. - Suppressor grid volts.
- Eg. - Grid volts.
- Ecg. - Control grid volts.
- Ek. - Cathode volts.
- Ef. - Filament volts.
- Eh. - Heater volts.

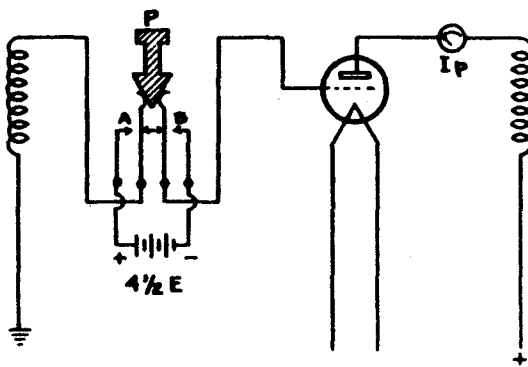

GRID TEST

The grid test is made by changing the grid bias, thereby obtaining an indication of the amplifying ability of the tube. Depressing P makes contact at A and B, and connects the battery in series with the grid circuit -- with the negative usually attached to the grid. The variation in plate current, produced by inserting and then disconnecting the battery, indicates the tubes amplifying merit. Tubes of the same type may give slightly different readings due to unavoidable variations involved in the manufacturing process.

TUBE CHARACTERISTICS.

Job A. With plate and grid voltages (E_p) and (E_g) held at constant value, the plate current (I_p) will not vary unless the filament voltage (E_f) is changed. This experiment is arranged to show the effect of filament voltage on plate current.

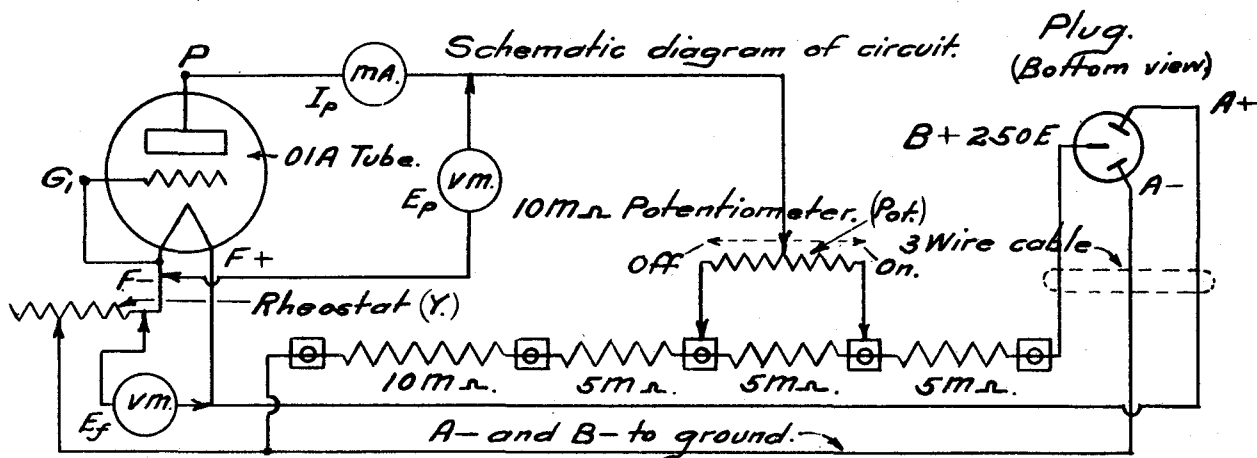
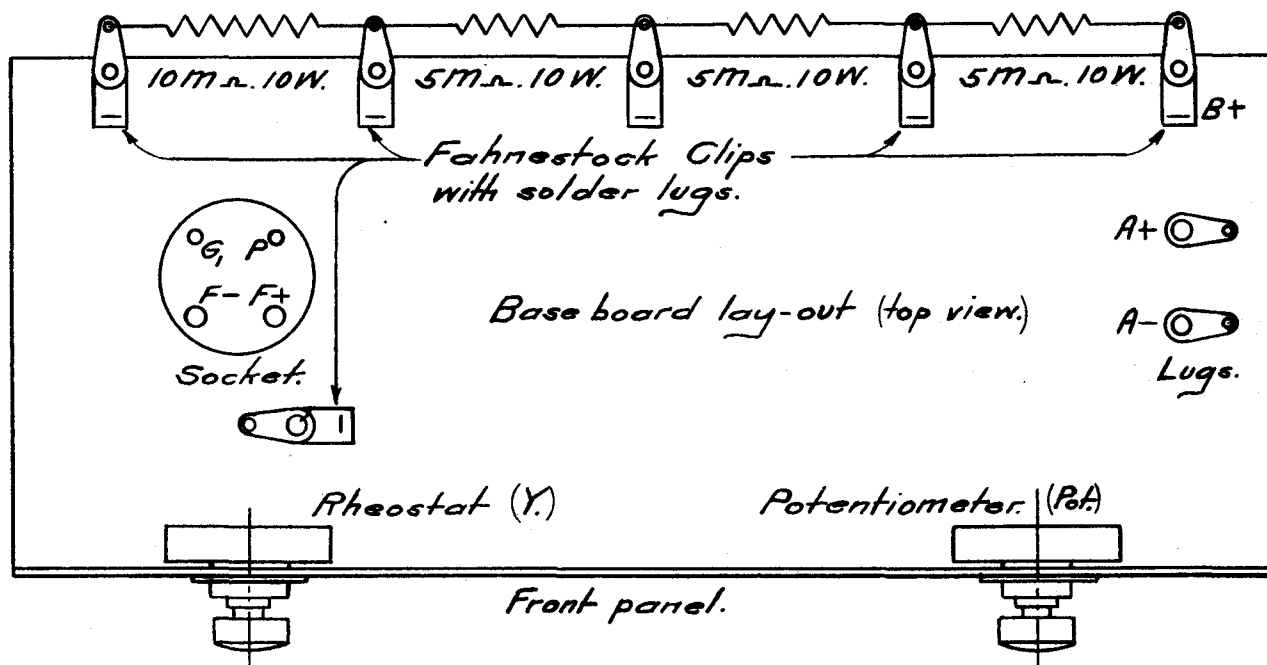

Resistance Test Chart.

F-prong to A-lead.	F+prong to A+lead.	G ₁ prong to A-lead.	Plate prong to B+lead.	B+ 250E lead to A-lead.	A+ lead to A-lead.
Rheo. off.		Rheo. off.	Pot. off.		Rheo. off.
Rheo. on.		Rheo. on.	Pot. on.		Rheo. on.

Caution: All resistance tests must be made with tubes out of sockets

TUBE CHARACTERISTICS.

After the circuit has been wired according to the diagram, and the connections have been carefully checked:

1. Trace diagram, filament circuit in black, plate circuit in red
2. Make resistance test and fill in resistance test chart.
3. Insert 3-prong plug and apply power to the test board.
4. Read E_f . Vary rheostat and note change in filament voltage. Turn rheostat full on; filament voltage should then be 6 volts.
5. With voltmeter connected from B plus side of MA to F minus, set E_p at 150 volts by adjusting the potentiometer Pot. If necessary, change Pot. to a different position on voltage divider. CAUTION - Never connect Pot. across more than one resistor in the voltage divider.
6. Place tube in socket and note change in E_f . Readjust E_p to 150 volts, E_f to 6 volts and tabulate filament voltage (E_f) against plate current (I_p) as indicated in data table.
7. Reduce E_f by 1 volt steps, readjust E_p to 150 volts and complete table.
8. Using values from table plot $E_f - I_p$ curve.

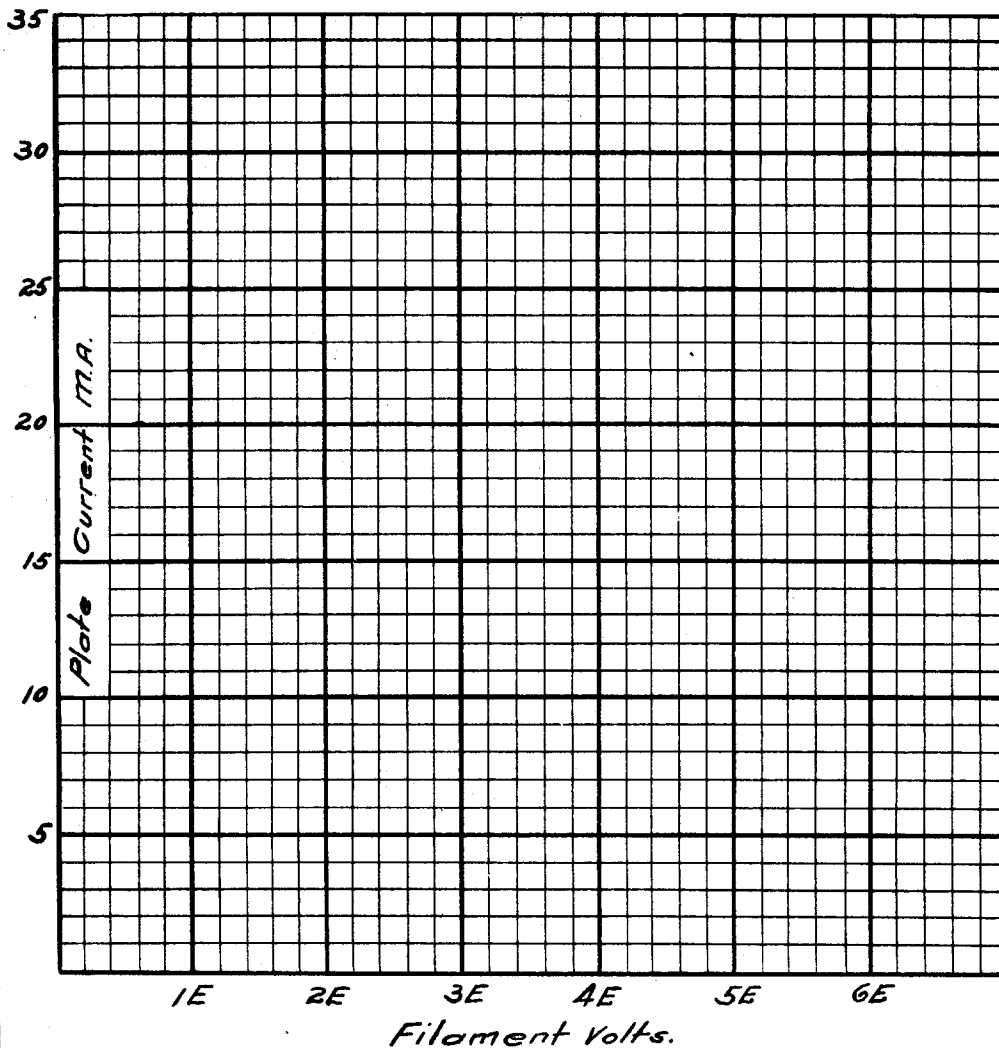

Data Table.

E_f	I_p
6	
5	
4	
3	
2	

TUBE CHARACTERISTICS.

PROCEDURE:

Read complete instructions before starting to work job.

1. Adjust E_f to 5E, to 45E and E_{g1} to values specified in section 1 on chart
2. Read and mark in section 1 and I_p for each value of E_{g1}
3. Adjust E_p to 90E and fill in section 2
4. Adjust E_p to 150E and fill section 3
5. Adjust E_f to 3E. Fill in section 4, 5 and 6 as instructed in 1, 2, and 3
6. Plot all six curves on chart below

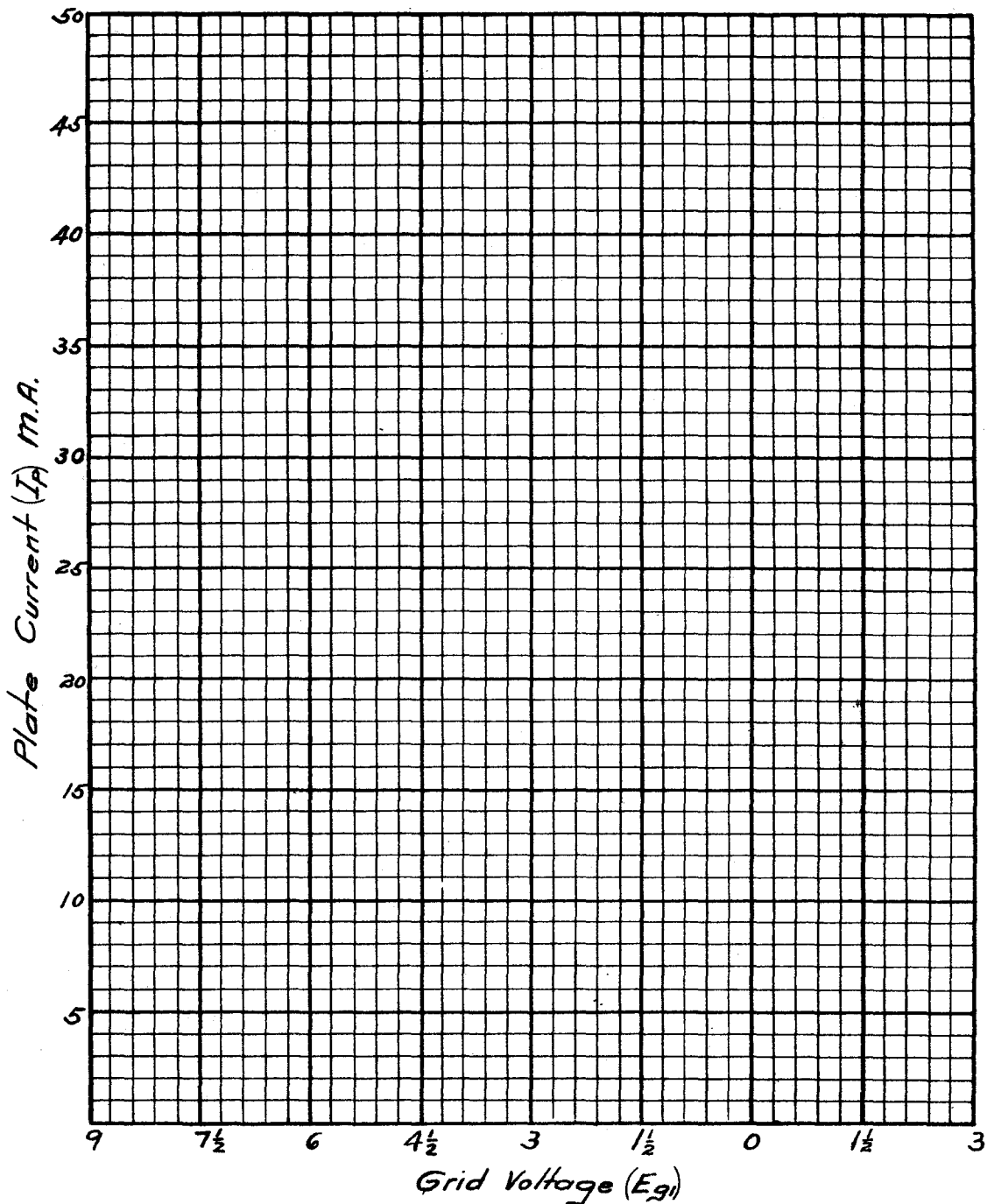

TUBE CHARACTERISTICS.

Job C.

When the grid voltage and the filament voltage applied to a three element tube are held at a constant value, the plate current will vary directly with the plate voltage. As the plate voltage is raised, the plate current will increase; as the plate voltage is reduced, the plate current will decrease. If the plate voltage is raised sufficiently to attract all the electrons emitted (saturation point) a further increase in plate voltage will not increase the plate current.

This experiment is designed to show how the plate current is affected by changes in plate voltage.

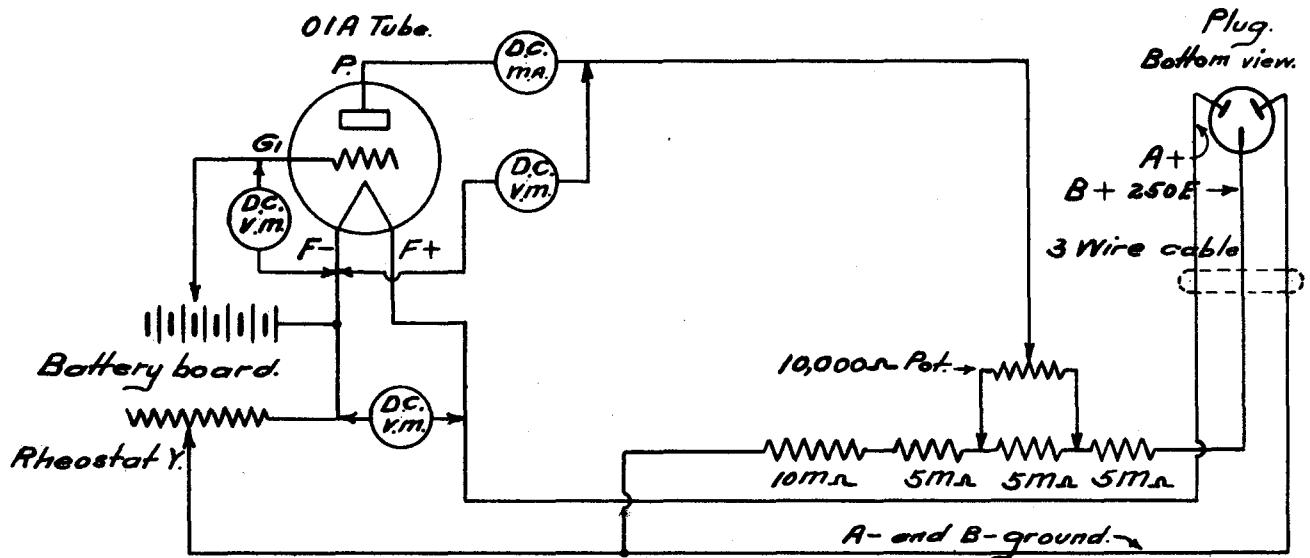

Data Table.

	Section #1	Section #2	Section #3
E_p	I_p when $E_{g1} = 0$	I_p when $E_{g1} = 6E$	I_p when $E_{g1} = 9E$
45			
65			
85			
105			
125			
150			

TUBE CHARACTERISTICS.

PROCEDURE:

1. Adjust E_f to 5 volts, E_{g1} to zero, and then vary E_p through the values indicated on the chart. Read and record I_p for each value of E_p .
2. Change E_{g1} to -6 volts and repeat #1 procedure.
3. Change E_{g1} to -9 volts and repeat procedure #1.
4. Plot curves in different colors for each group of data on the graph below.

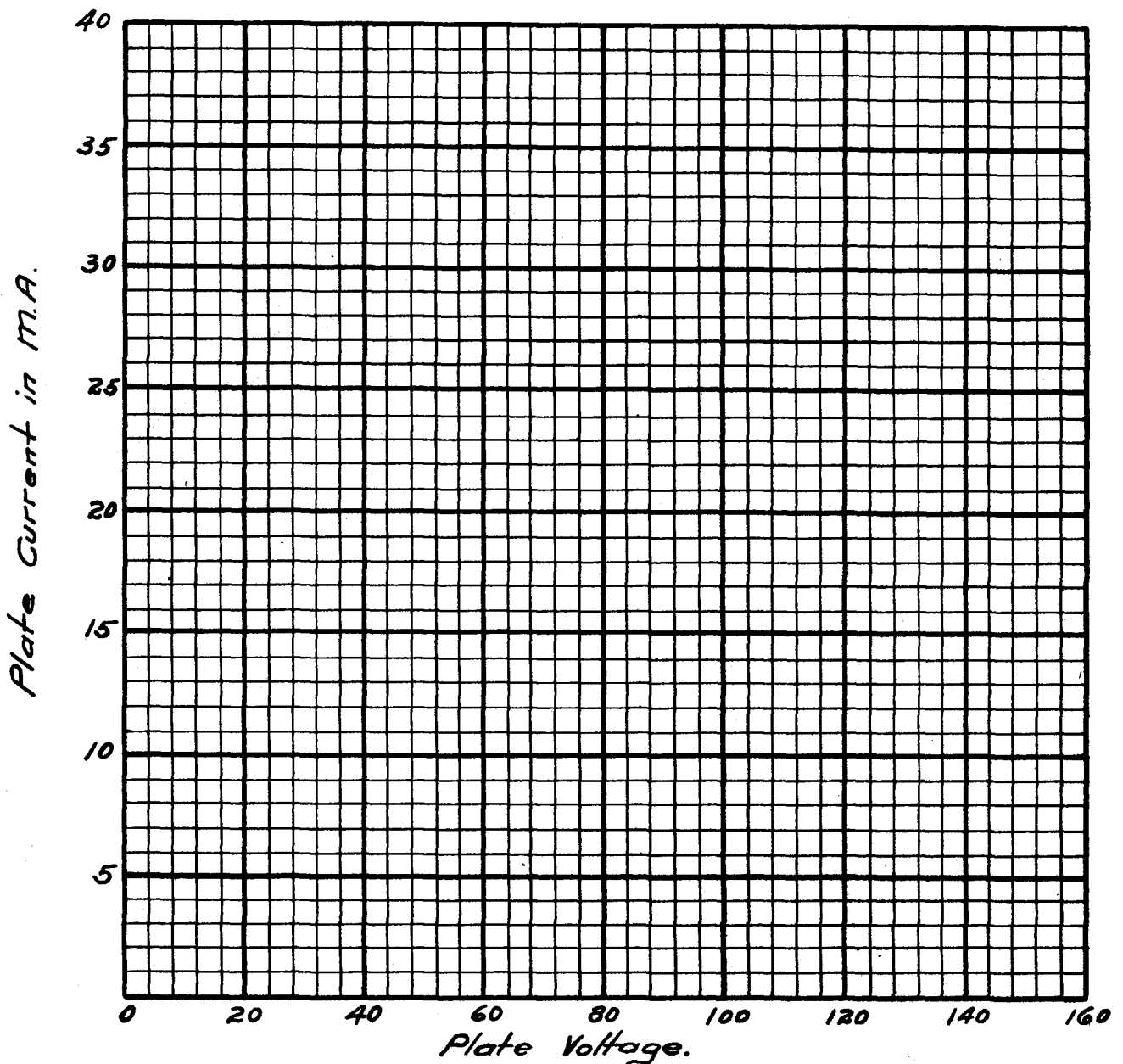

TUBE CHARACTERISTICS.

Job D.

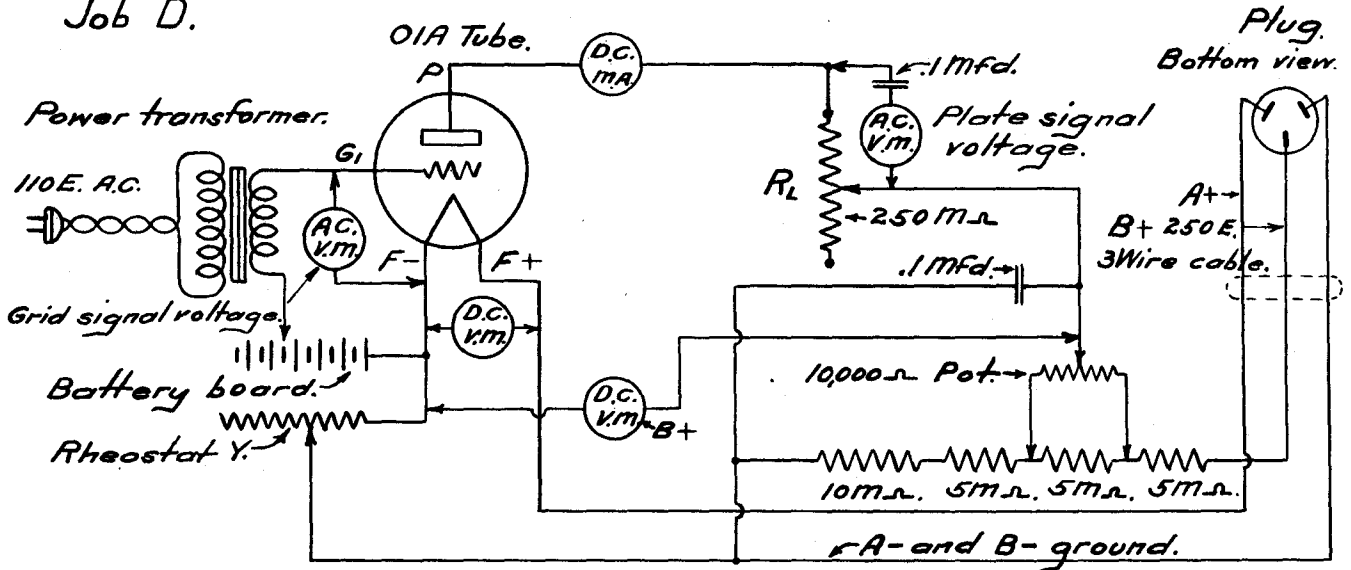

When an A.C. signal is injected into the grid circuit, amplified variations of a similar character will appear in the plate circuit.

$B+ = 135 E.$ $E_f = 5 E.$ $E_{g1} = 4\frac{1}{2} E.$						
$R_p.$	Section 1. Grid signal = 0		Section 2. Grid signal = 6.3 E.		Section 3. Grid signal = 11.3 E.	
	Average $I_p.$	Plate signal voltage.	Average $I_p.$	Plate signal voltage.	Average $I_p.$	Plate signal voltage.
0 Ω						
5 M Ω						
10 M Ω						
20 M Ω						
30 M Ω						
40 M Ω						
60 M Ω						
100 M Ω						
200 M Ω						

The magnitude of the signal voltage appearing in the plate circuit will depend upon; A. Magnitude of signal applied to grid circuit. B. Amplification factor of the tube. C. Value of the plate load resistance.

This experiment is designed to show how these factors are related.

TUBE CHARACTERISTICS.

PROCEDURE:

1. Insulate all high voltage transformer secondary leads.
2. Wire circuit according to diagram.
3. Insert 3-prong plug, adjust E_p to 135E, E_f to 5E, E_{g1} to 4 1/2 E and, with no AC signal applied, record I_p in Section 1 of data chart for R_L values indicated.

CAUTION - Always pull out 3-prong plug when setting R_L with an ohmmeter to the value specified, and readjust voltages to correct values before proceeding.

4. Apply 6.3 E AC signal to grid and fill in Section 2.
5. Apply 11.3 E AC to grid and fill in Section 3.
6. Plot all average I_p and plate signal curves on graph below.

Trace signal voltage curves in red, plate current in black.

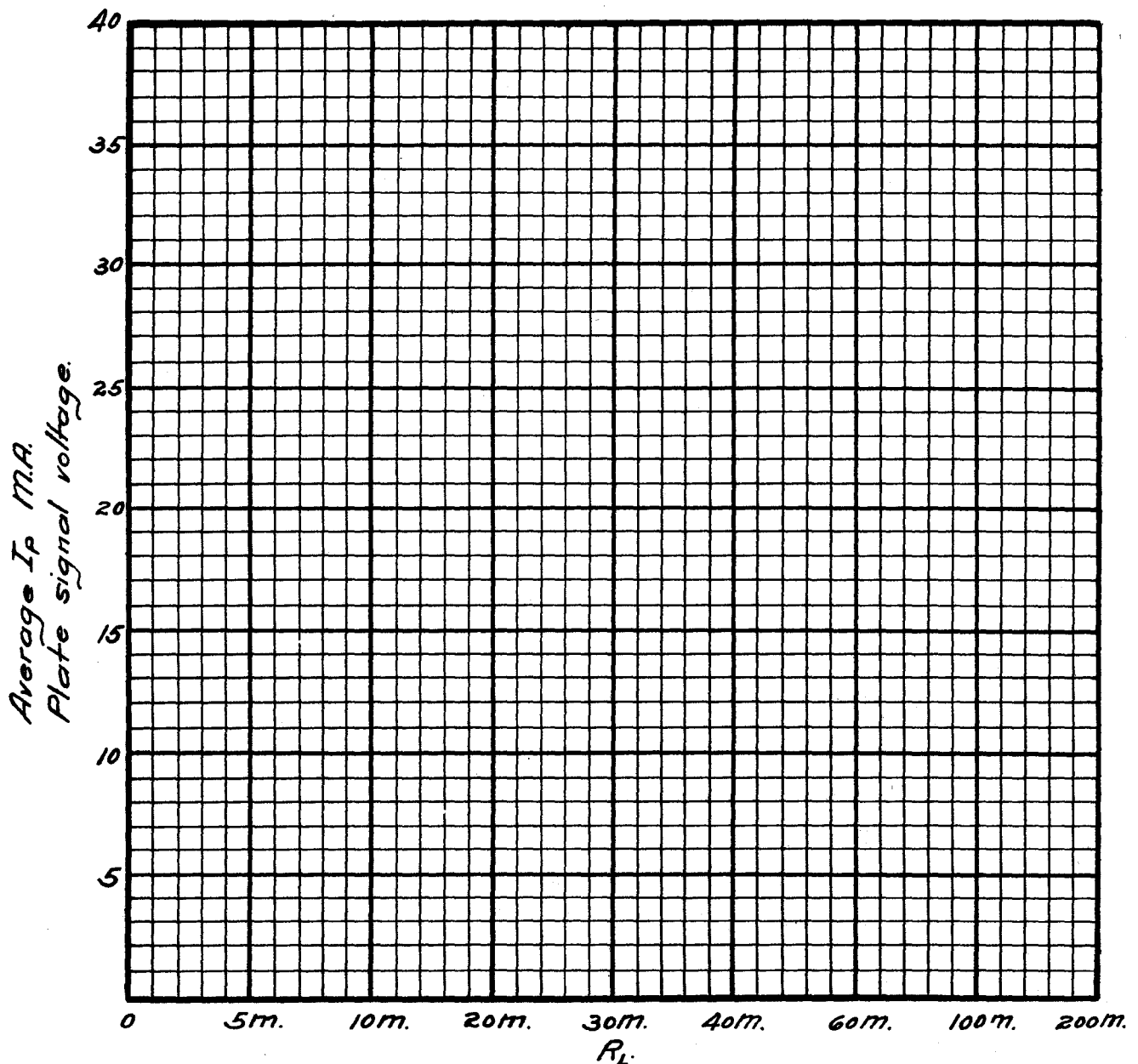

PHILCO DYNAMIC TESTER

MODEL 030

The Philco Dynamic Tester is extremely useful in locating defects in any type of radio with a minimum of time and effort. It operates on the principle of amplifying and reproducing a signal taken from any circuit of a radio in which a signal is normally present. It is easy to use, requiring no tuning to amplify signals of any frequency (radio, intermediate or audio frequency).

The Dynamic Tester not only indicates the presence of a signal but gives a comparative idea of its intensity. It can also be used to test public address amplifiers, microphone circuits and phonograph pickup circuits. The tester is designed to operate on a 115 Volt, 50 to 60 cycle A. C. power supply.

TUBE COMPLEMENT

The tester contains four tubes. Three of the tubes (types 7C7, 7A5 and 7Y4) are mounted in the tester case, and a 6F5GT tube in the test prod assembly.

The complete test prod assembly including the tube it encloses can be removed from the socket at the end of the cable. The tube can be removed from the shield by grasping one of the base pins or locating pin with a pair of pliers. In replacing this tube in the shield, it is necessary to remove the switch from the end of the shield to connect the grid clip to the control grid cap of the tube.

Connecting for Operation

1. Connect the dynamic tester to a 115 volt, 50 or 60 cycle power supply. Turn the attenuator control to the right until the power switch is in the "ON" position.
2. Connect the ground wire clip to the radio chassis. In the case of an A.C.-D.C. set, it might be necessary to reverse the power plug to either the dynamic tester or the radio under test or both for a minimum of hum pickup in the dynamic tester.
3. Turn the radio "ON," and tune in a strong local station. If the radio is inoperative, turn the dial to the setting for a local station. If a strong local station is not on the air, connect a signal generator and tune in any audio modulated R.F. signal in the broadcast or short-wave band. The following procedure should be used in testing the radio and other special apparatus.

TEST PROCEDURE

Beginning with the input terminal (antenna or loop) touch the test prod to the various points at which a signal should be present, particularly the grid and plate of each amplifier tube. These various test points are indicated in the "Testing Signal Circuits" procedure and schematic diagram on the following pages.

At the R.F. end of the set, the signal level switch on the test prod assembly should be kept in the "High" position toward the tip. The attenuator should be turned all the way on when testing in the R.F. sections of the set and gradually retarded as the audio amplifier circuit is approached. As the test prod is moved from the test points in the R.F. section toward the audio circuit the signal should increase in volume. When testing the audio amplifier, the switch on the prod assembly should be turned to the "LOW" position.

When it is impossible to obtain a normal signal at some particular amplifier stage, testing for the exact location of the trouble can be completed by touching the test prod to the adjacent parts of the circuit.

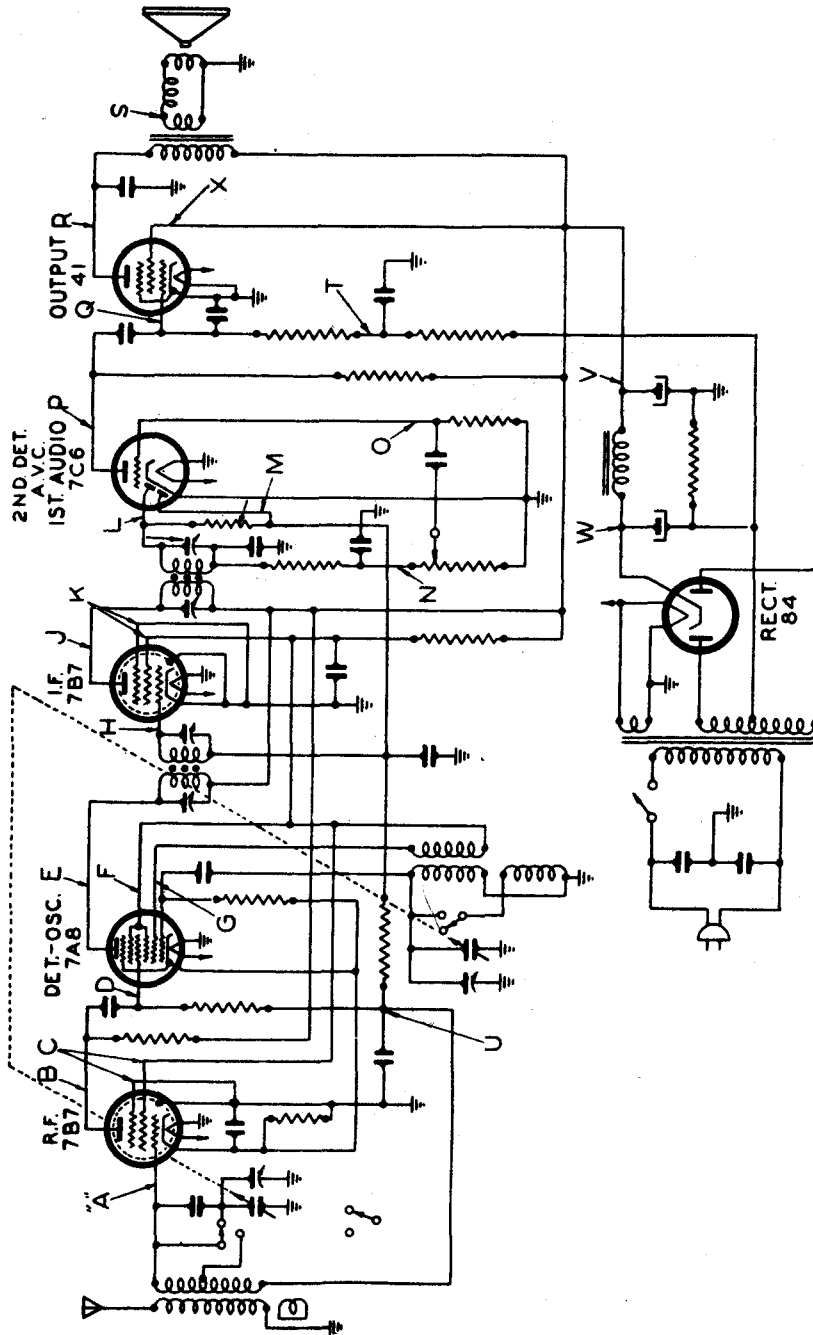

TESTING SIGNAL CIRCUITS

1. ANTENNA CIRCUIT TEST

- a. Place test prod at point "A"; with the attenuator on full, the signal should be heard weakly. The band switch should be tested in broadcast and S.W. positions, with a signal tuned in for each position.

2. R. F. CIRCUIT TEST

- a. Apply test prod at point "B" (plate of R.F. Tube); an increase in signal strength should be noted. When testing the S.W. band a signal should be tuned in above the middle of the tuning range (tuning condenser at least half meshed).

3. CONVERTER CIRCUIT (1st Detector Stage)

- a. Connect test prod to point "D" (grid signal should have same signal strength as point "B").
- b. Attach prod to point "E" (plate). The signal should increase greatly over point "D" (grid).

4. OSCILLATOR CIRCUIT

- a. Touch test prod to oscillator grid or plate "G." Momentarily short circuit the plate of oscillator section of gang with metallic instrument or wire. A click should be heard in the speaker of the tester when the short is applied and also when it is removed.

5. I. F. CIRCUIT

- a. Connect prod to point "H" (grid I.F.). Signal should be approximately the same as at point "E."
- b. Apply prod to point "J," (plate of I.F. tube). Signal should increase in strength over point "H" grid.

6. 2nd DETECTOR—A.V.C.

- a. Attach prod to diode plate, point "L." Signal should be heard.
- b. Apply test prod to points "M" and "U." A signal should NOT be heard at either of these points. If signal is heard there is a possibility of the A.V.C. by-pass condenser being open.

7. FIRST AUDIO STAGE

- a. Apply test prod to high end of volume control point "N"—push switch on test prod to "LOW" position. A weak audio signal should be heard.
- b. Apply test prod to point "O" (volume control). Volume control of radio in maximum position, signal should be heard with equal strength of point "N."
- c. Attach test prod to point "P" (plate of audio tube). Signal will greatly increase in strength if tube and associated circuit preceding are normal.
- d. While the illustrative diagram shows the 2nd detector A.V.C. and 1st audio stages in one tube, the same test as given above is used when these circuits are in separate tubes.

and the signal strength noted. The signal should have greater gain than when tested at the 1st audio stage.

8. AUDIO OUTPUT CIRCUITS

- a. Connect test prod to point "Q" (grid). Signal should have same gain as was noted at point "P."
- b. Attach prod to point "R." Signal should have tremendous gain over the input point "Q."
- c. Apply test prod to point "S." Signal should be lower in volume than at point "R," depending upon ratio of transformer.

ADDITIONAL USES AND SPECIAL TESTS

While the tester is primarily intended to indicate the presence of a signal in a circuit where it should normally be, it can also be used to detect signals in circuits in which the signals are supposed to be excluded through the action of by-pass condensers. In addition, it will be found useful in checking any special apparatus which develops an R.F. or audio signal.

1. OPEN BY-PASS CONDENSERS

a. Automatic Volume Control (A.V.C.) Circuit

By applying the test prod to points "M" and "U" the filtering condition of the A.V.C. circuit can be checked. A signal SHOULD NOT be heard at either of these points. If a signal is heard it will indicate trouble in the filter condensers or resistors of the A.V.C. circuit.

b. Screen grid circuits.

Application of the test prod to any screen grid tube contact will indicate the filtering action of the by-pass condensers. Under normal operation a signal should NOT be present. If the signal appears in these circuits it will indicate trouble in the by-pass condensers (being open or partially open).

2. HUM (HUM FILTER CONDENSERS)

- a. Abnormal hum can be located with the tester by applying the test prod to points "O" and "T" in the audio filter circuit. If abnormal hum is heard at any of these points it will indicate trouble in the filter resistors or by-pass condensers. Hum comparison tests can be made in any circuit with the tester.

3. LEAKY COUPLING CONDENSERS (Between Audio Stages)

The Dynamic tester will also be found helpful in locating leaky coupling condensers (noisy) in audio circuits such as the condenser between points "P" and "Q." If this condenser is leaky the signal will be noisy or weak at point "Q." If the condenser is shorted no signal will be heard at "Q." This test also is useful in testing coupling condensers in the R.F. such as at points "B" and "D."

4. PHONOGRAPH CIRCUITS

The dynamic tester will also test phonograph pickup circuits. The test prod is applied to the various connections in the phonograph circuit beginning at the pickup and working back through the audio amplifier stage to the speaker.

5. MICROPHONE CIRCUITS

The Dynamic tester works equally well in testing microphone circuits. The procedure being the same as phonograph circuits, beginning, however, with the

PORTABLE INTERFERENCE LOCATOR

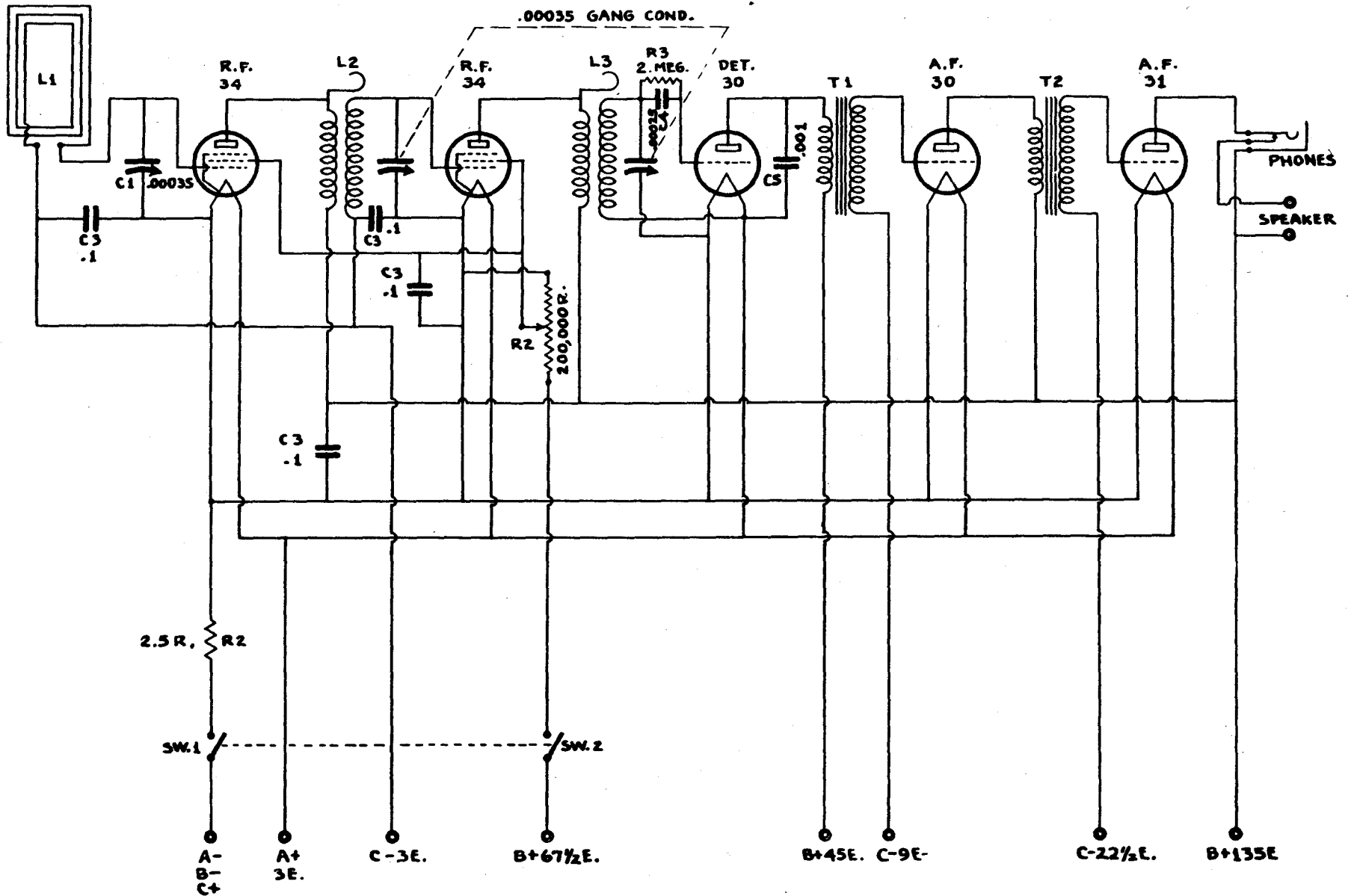

LOOP DIRECTIONS AND INTERFERENCE TRIANGULATION

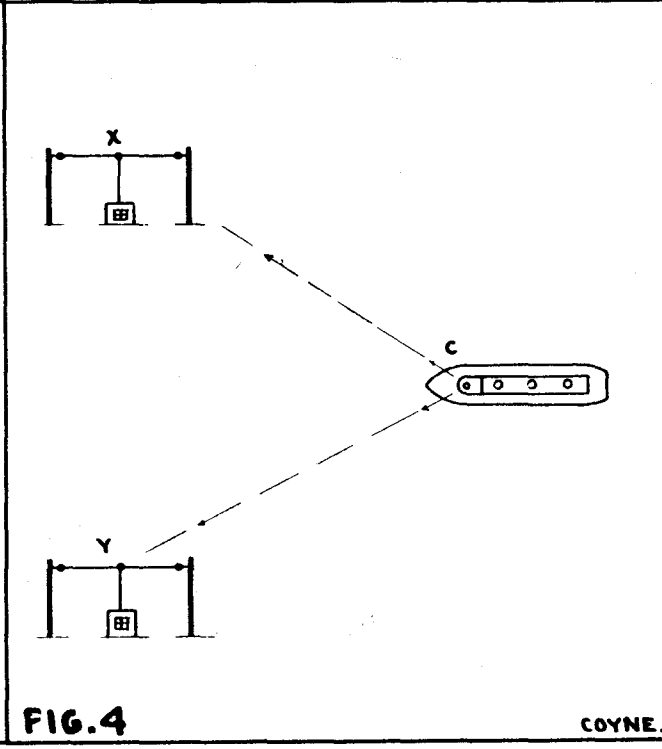
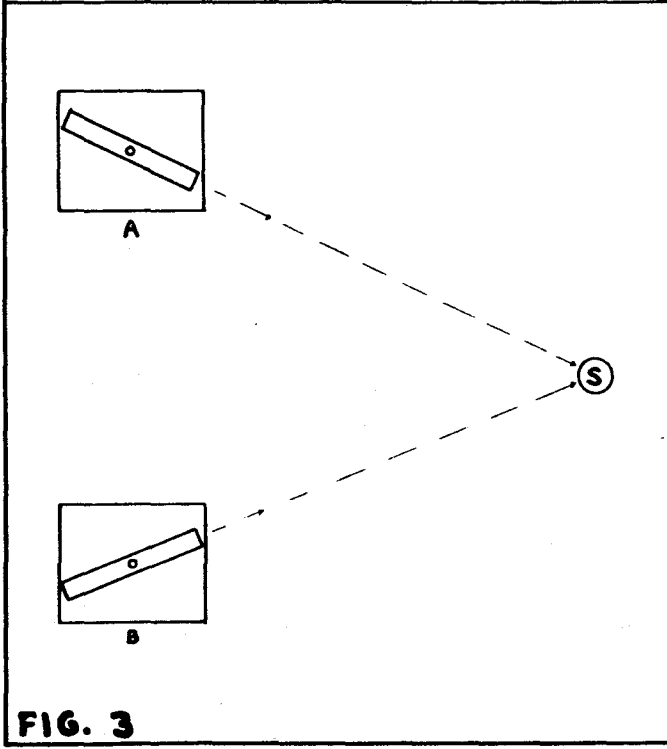
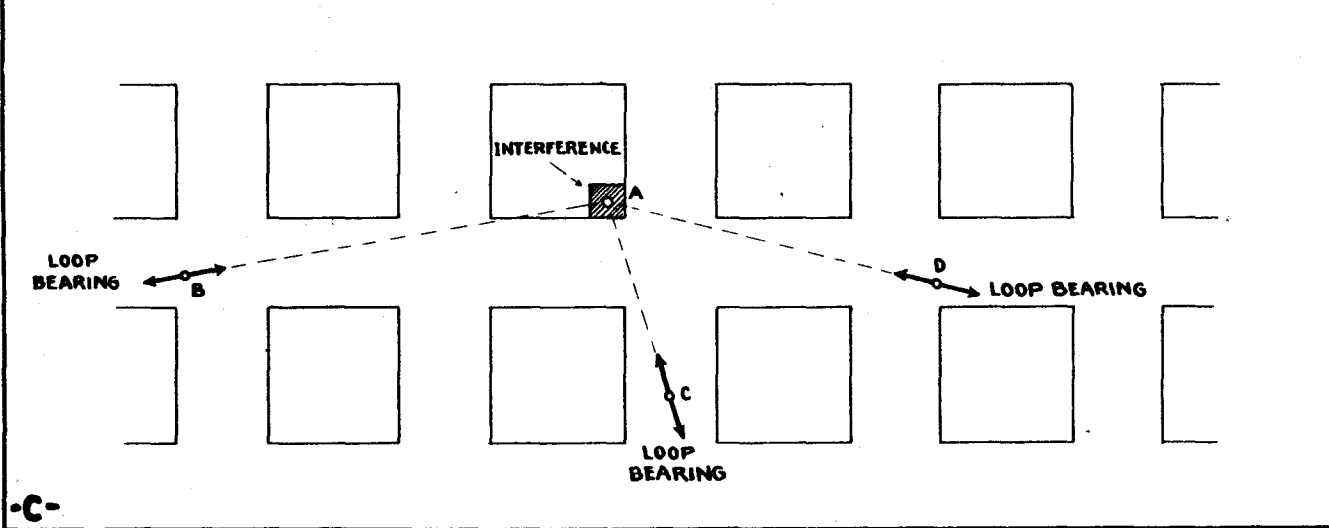
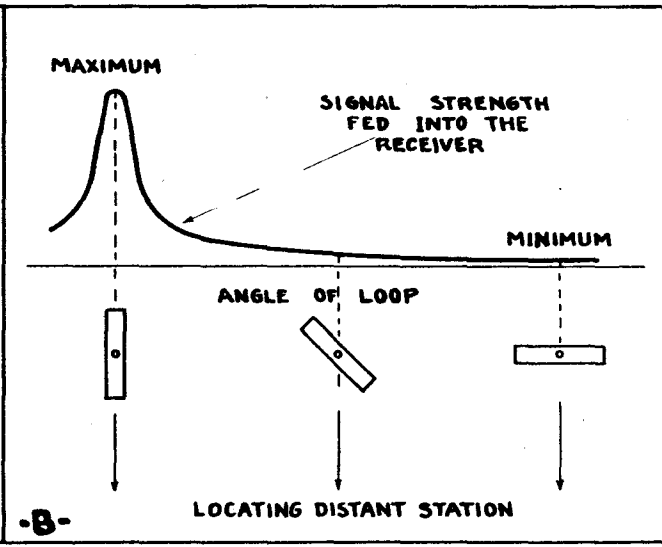
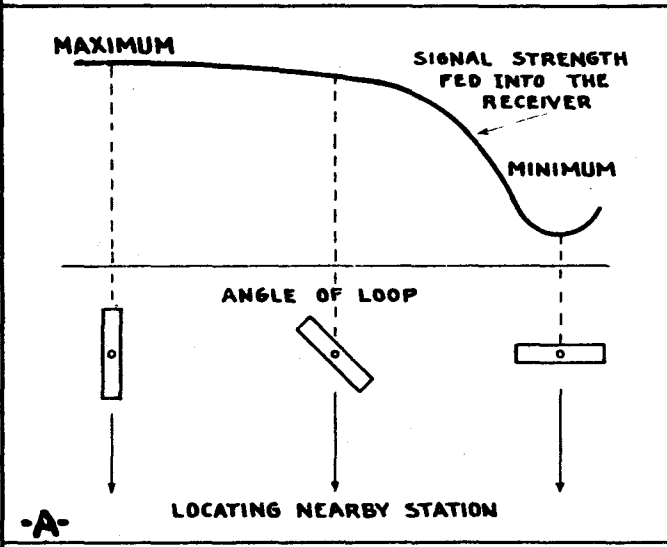

OPERATION AND CONSTRUCTION OF INTERFERENCE LOCATOR

This receiver must be self-contained, nothing except the loop should be outside the case. The cabinet must be completely shielded, top, bottom, and sides, with no joints or openings at any point. All voltages and specifications should be followed very closely for efficient operation and good results. This receiver being a loop operated unit, the following instructions are very important to insure proper operation.

If the loop is turned so that it is pointed edgewise toward the transmitting station, radio waves from that station will travel the greatest distance between the two sides of the loop thus setting up the greatest voltage and consequently the signals will be strongest. When the loop is turned so that its flat surface is toward the transmitting station, the signal strength will be least. In the latter instance, the advancing radio waves strike both sides of the loop at the same instant, generating exactly equal and opposite voltages which balance each other out completely leaving no signal for the receiver, except that due to loop capacity.

Due to this directional effect of the loop aerial it is possible to partially tune out an undesired station by turning the loop broadside to it. Pointing the loop will greatly increase the signal strength from a distant station. This is one of the advantages of the loop.

In using the loop it will be found that the signal strength from a near-by station remains approximately the same until the loop is turned almost at right angles to the station. The signal strength will then show a sudden and decided decrease during the last few degrees of loop movement as in Figure 2-A.

On the other hand, the signal strength from a distant station will show a very gradual increase as the edges of the loop are brought into line with the direction of the radio waves; but during the final few degrees of loop movement, which brings the loop directly in line with the station, a decided and sudden increase in signal strength will be noticed, as shown in Figure 2-B.

When used as a direction finder the operating principles are practically the same. A direction finder consists essentially of a receiver mounted in a completely shielded cabinet and equipped with the directional loop also. Due to the shielding the receiver will not be affected by radio waves or signals except those coming through the loop. By turning the loop it is possible to tell from which direction the interference signal is coming. A transmitting station or interfering device as in "A" in Figure 2-C may be located with the aid of such a receiver, by tuning in the signal from two or more positions and noting the bearing of the loop in each case. At the intersection of the bearings or lines such as those taken from B, C and D, in Figure 2-C, the location of the transmitter or interfering device may be determined.

Shielding is the most important factor in the construction of this receiver. It is especially important that the coils and all units are completely shielded, in many instances the receiver is built into a portable typewriter case (these cases can be purchased very reasonably). The parts used are those of an ordinary battery set, using regular broadcast coils and condensers. The values marked in the diagram should be used to insure best results. The two-volt tubes are most practical because of the low current drain. The source of supply for the filaments consists of 2 dry cells. The "B" supply is furnished by small 45-volt batteries especially designed for portable use. The "C" bias is obtained from three 7.5 volt C-batteries.

We will now consider the design and construction of the loop as it is one of the essential parts. In building the loop for the receiver, the safest method is to use an excess length of wire to begin with. A loop antenna usually consists of a rectangular or circular coil of from 10 to 15, or 20 turns of insulated wire (bell wire, or #20 D.C.C. enameled) on a supporting framework. The framework may range from one to three feet in diameter, this being a matter of choice. A small area is not as sensitive and a large loop may be a little too bulky. A loop approximately two feet in diameter is recommended for this particular receiver. After the loop is wound, a high wave-length or low frequency broadcasting station should be tuned in. If the dial setting of the loop tuning condenser is much too low, that is, if too little of the condenser is used for this wave-length, wire should be removed from the loop. Take off one turn at a time. The loop should be retuned after each alteration and wire should be removed until the dial setting is correct from the station being received.

When used as a radio compass: A radio compass consists essentially of a receiver mounted in a completely shielded cabinet and equipped with a directional loop. The receiver is not affected by radio waves or signals except those coming through the loop. By turning the loop it is possible to tell from which direction of the compass the signal is coming. A transmitting station as at "S" in Figure 3 may be located to position with the aid of such a receiver. The receiver is tuned in on the station from two or more positions and the bearing of the loop is noted in each case. At the intersection of the bearings, such as those taken from position A & B in the Figure, the location of the transmitter may be determined.

For use on ship board, the radio compass is in the form of a large loop carried usually above the pilot house of the ship. Compass signals are transmitted from two or more stations. These signals are distinguished from each other as received by the ship. The location of the shore station is known to the navigators and the ship's position with reference to the shore stations may be determined by triangulation. Such a position finding method is illustrated in Figure 4, the ship's compass being designated as "C" and the shore stations as X and Y.

LIST OF PARTS NEEDED IN CONSTRUCTING INTERFERENCE LOCATOR

- One Set of R.F. coils, L2 and L3.
- One two-gang condenser, 350 mmf., C2 and C3.
- One single condenser, 350 mmf., C1.
- Two midget transformers (A.F.), T3 and T4.
- One D.P.S.T. switch, Sw. 1.
- One variable resistor, 2 meg., R1.
- One wire wound resistor, 2.5 ohms, R2.
- One carbon resistor, 2 meg., 1.5 watts, R3.
- Four condensers, .1 mfd., 330 volt rating, C3.
- One mica condenser, 250 mmf., C4.
- One mica condenser, .001 mfd., C5.
- Two type 34 tubes.
- Two type 30 tubes.
- One type 31 tube.
- One special case with loop antenna (L1) in cover.
- Two #6 dry cells (A battery)
- Three C batteries, 7.5 volts.
- Three B batteries, (45 volts, portable size).
- One bakelite strip with five four prong sockets.
- One 5 inch magnetic speaker.
- Knobs, wire, hardware, etc.

CROSLY 53-54-57 (NEW BUDDY).

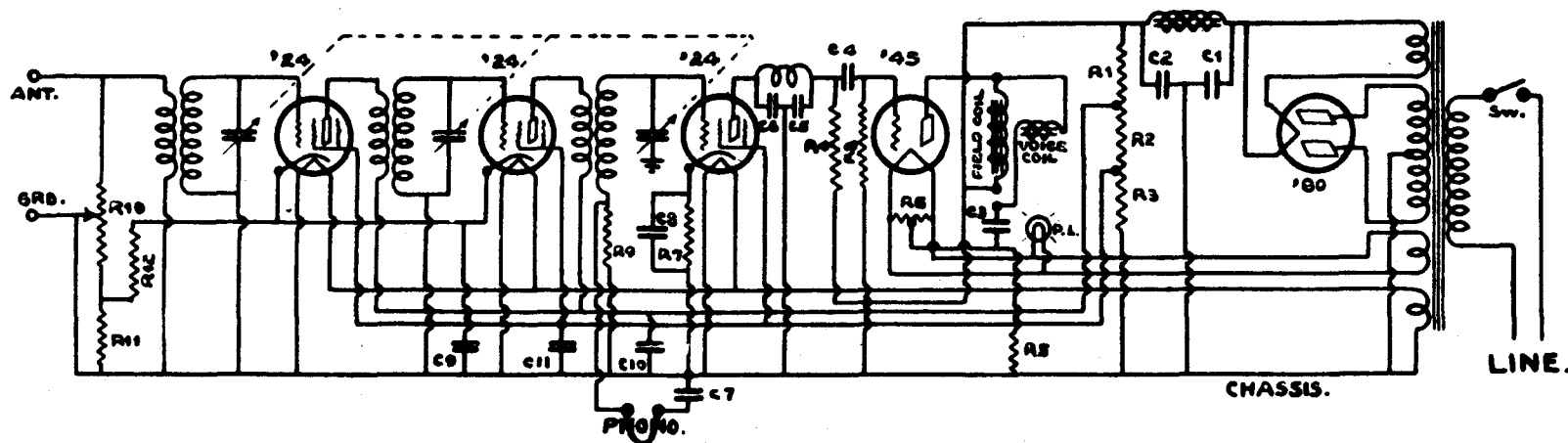

- R 1 --- 10,000 Ohms
- R 2 --- 10,000 "
- R 3 --- 10,000 "
- R 4 --- 150,000 "
- R 5 --- 1,650 "
- R 6 --- 25 " each side of center tap.
- R 7 --- 10,000 "
- R 8 --- 1 megohm
- R 9 --- 1 "
- R10 --- 25,000 ohms
- R11 --- 20,000 "
- R12 --- 440 "

- C 1 and C 2 (Electrolytic) 8 Mfd. each.
- C 3 --- 0.5 Mfd.
- C 4 --- 0.1 "
- C 5 --- 0.00025 mfd.
- C 6 --- 0.00025 "
- C 7 --- 0.1 "
- C 8 --- 0.5 "
- C 9 --- 0.1 "
- C10 --- 0.5 "
- C11 --- 0.1 "

Line voltage 110.		Vol. Control set at Maximum.					
Tube		Operating Voltages.					
Type	Location	Fil.	Plate	Grid	Cath.	S.G.	Plate M.A.
'24	1 R.F.	2.1	160	3.1	----	85	3.0
'24	2 R.F.	2.1	160	2.1	----	85	3.0
'24	Det.	2.1	215	9.0	----	85	3.0
'45	Power	2.2	230	45.0	----	----	33.0
'90	Rect.	4.1	340	----	----	----	45.0*

* NOTE: - INDICATES TOTAL PLATE CURRENT.

Emerson Radio

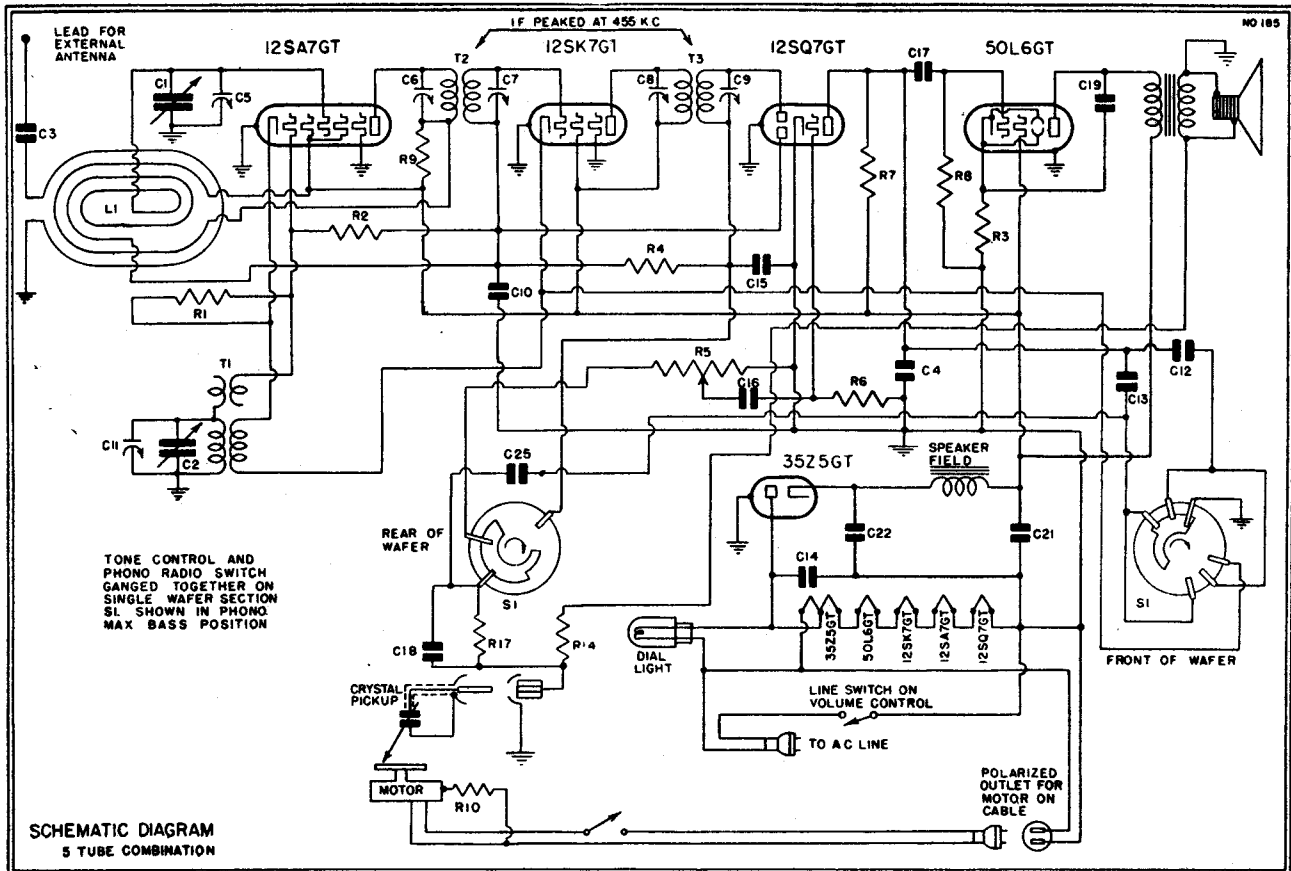

SCHEMATIC FOR MODEL FS

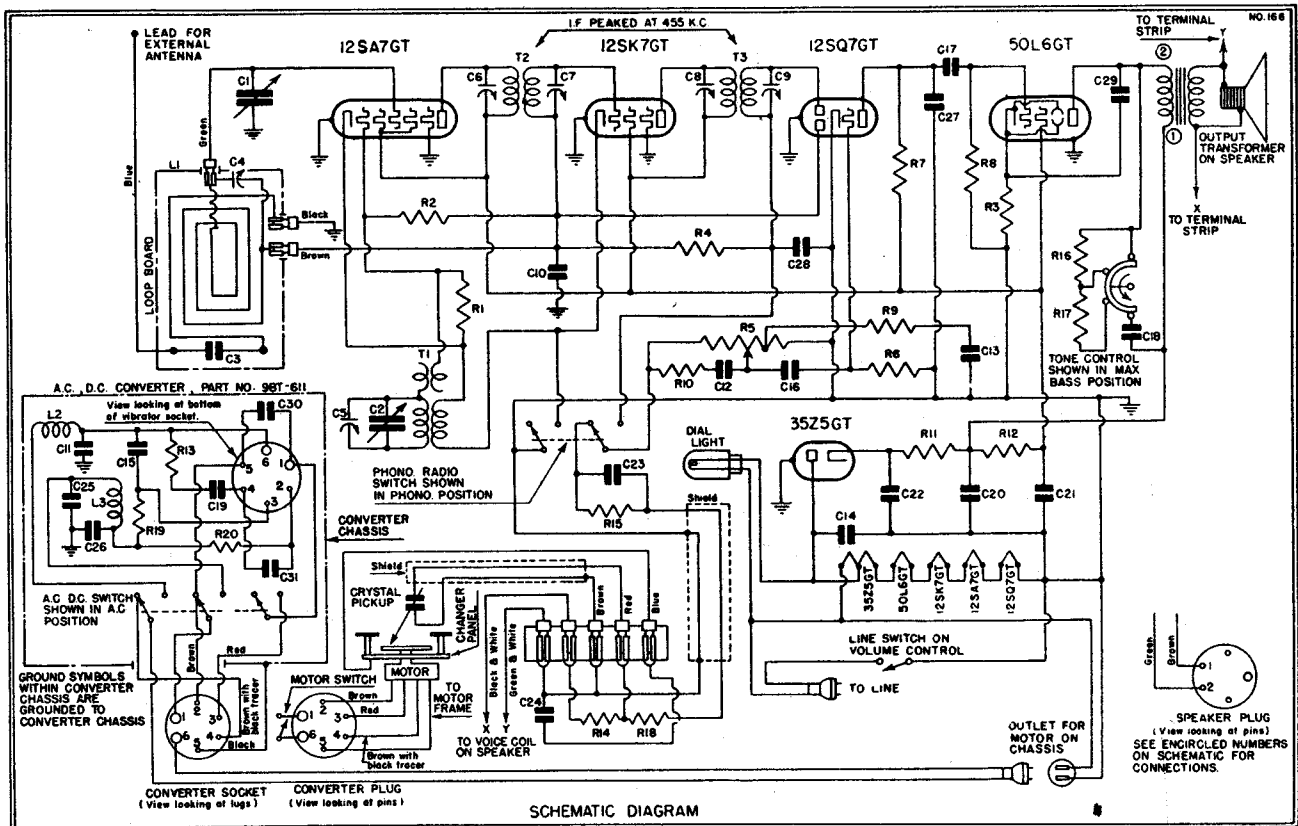

SCHEMATIC DIAGRAM FOR MODEL FB2

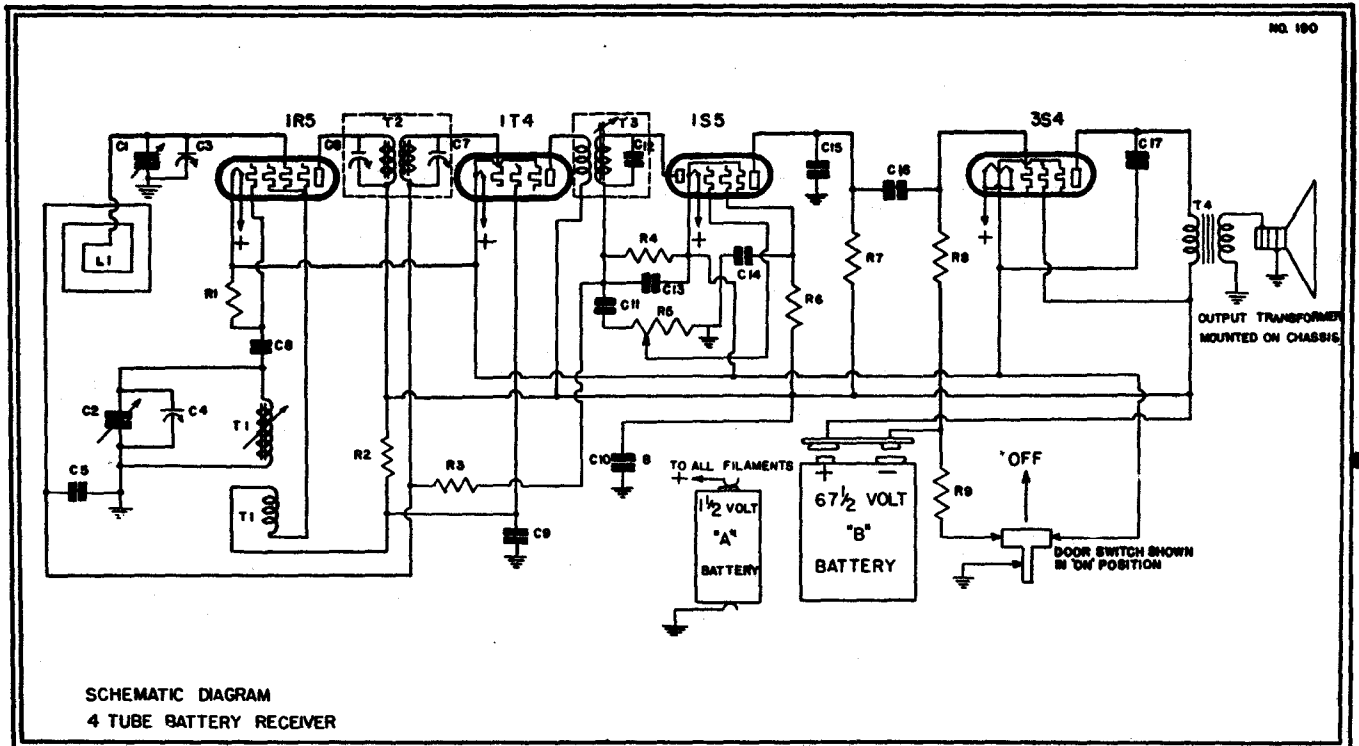

FR SCHEMATIC DIAGRAM FOR CHASSIS BEARING SERIAL NUMBERS BELOW 4,818,700

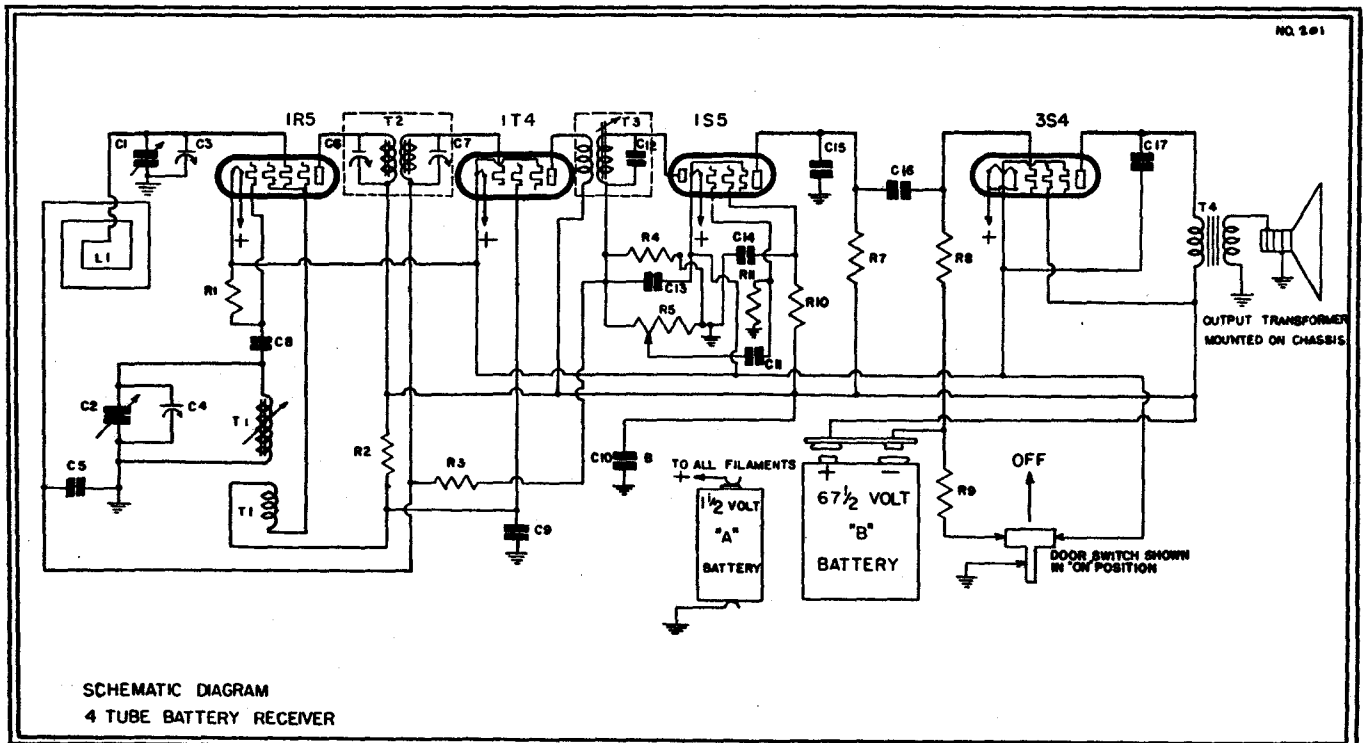

FR SCHEMATIC DIAGRAM FOR CHASSIS BEARING SERIAL NUMBERS ABOVE 4,818,700

Emerson Radio

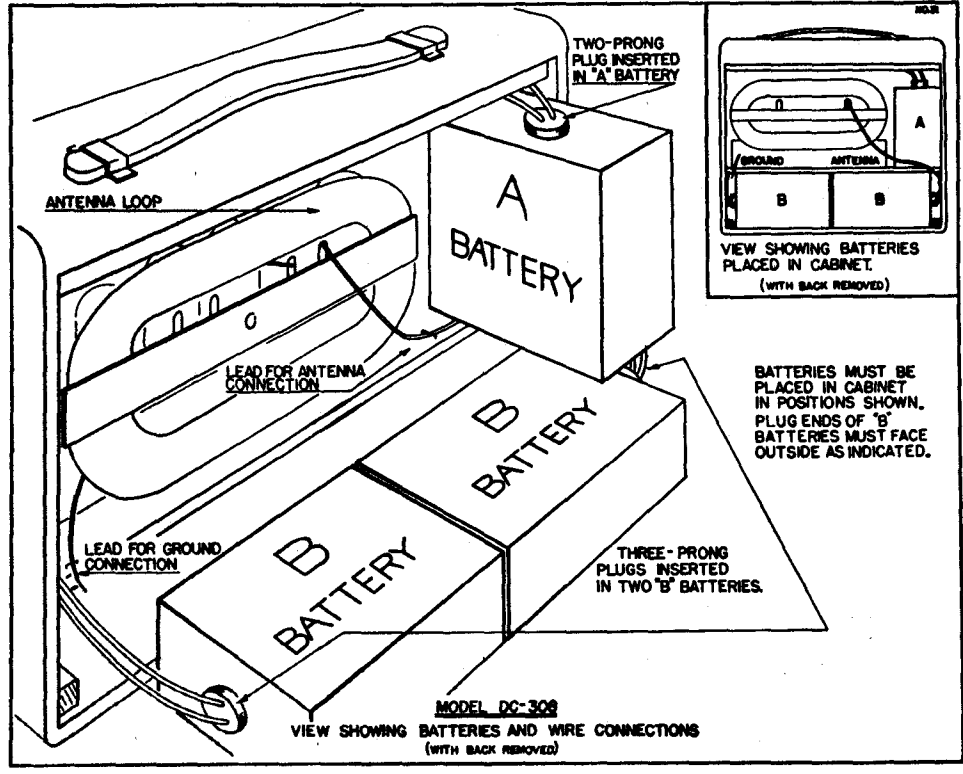
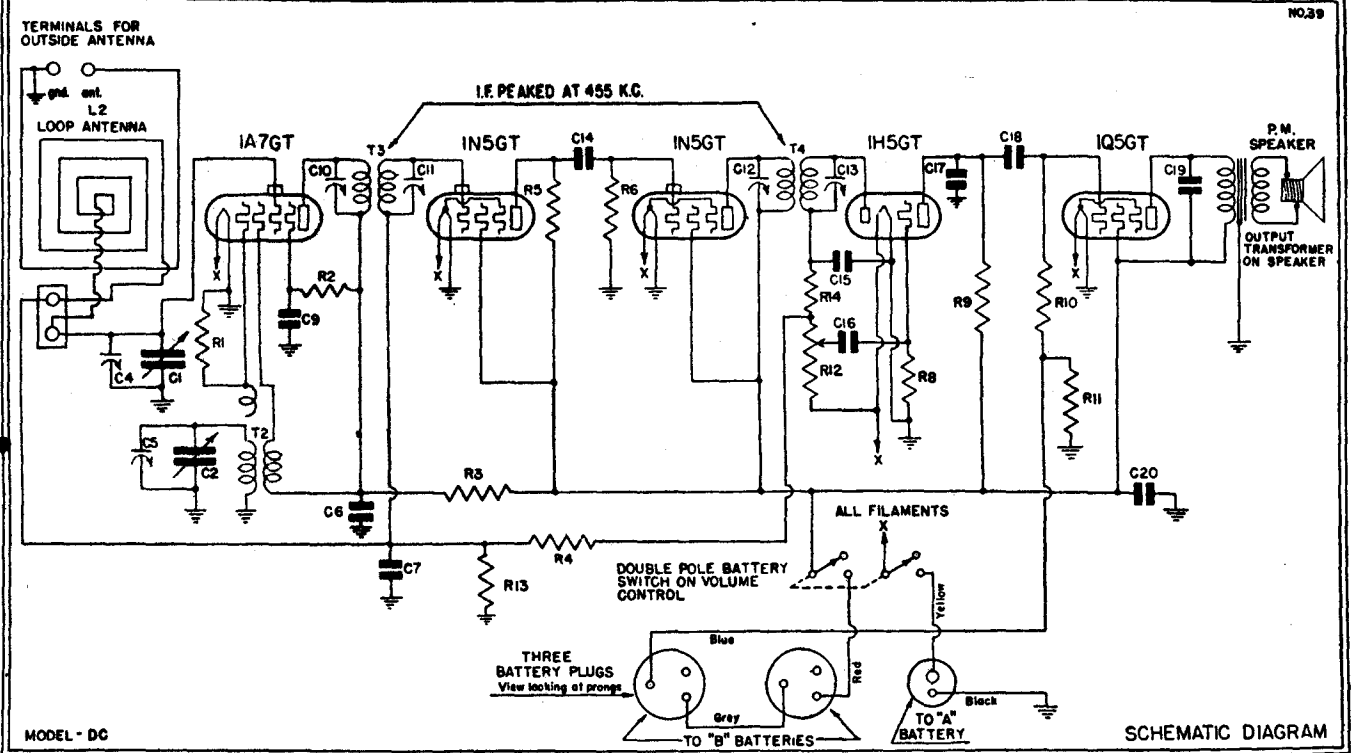

Emerson Radio

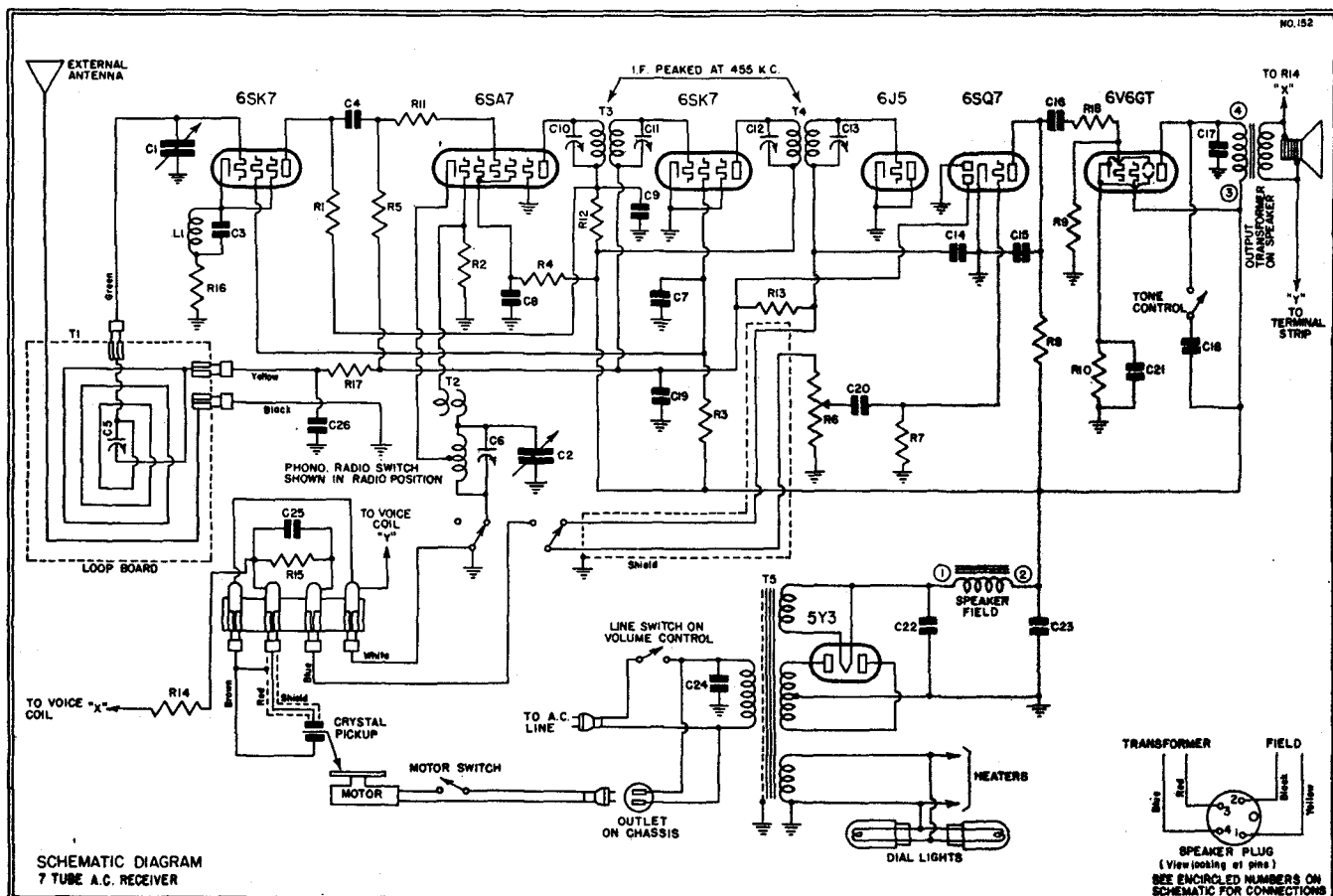
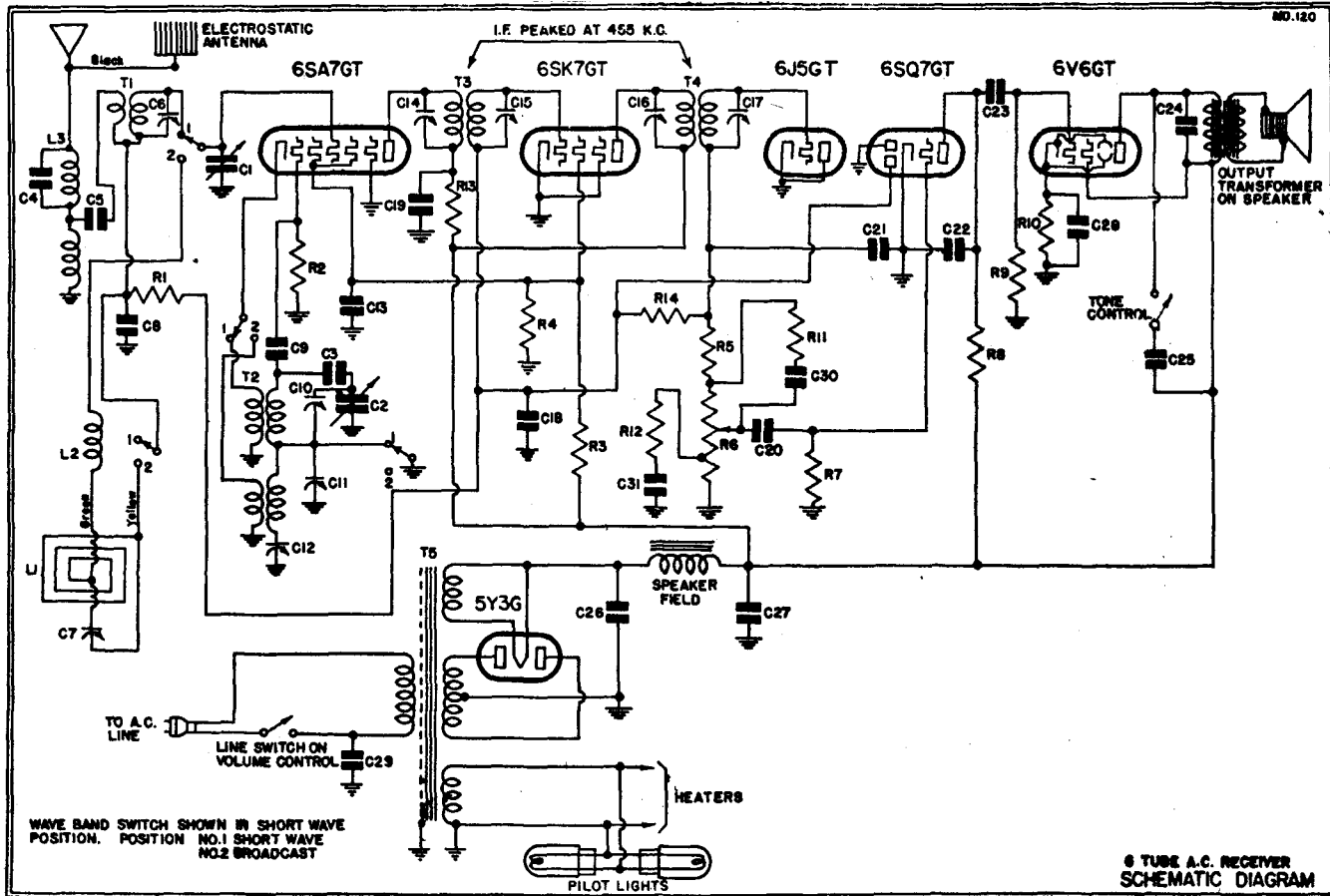

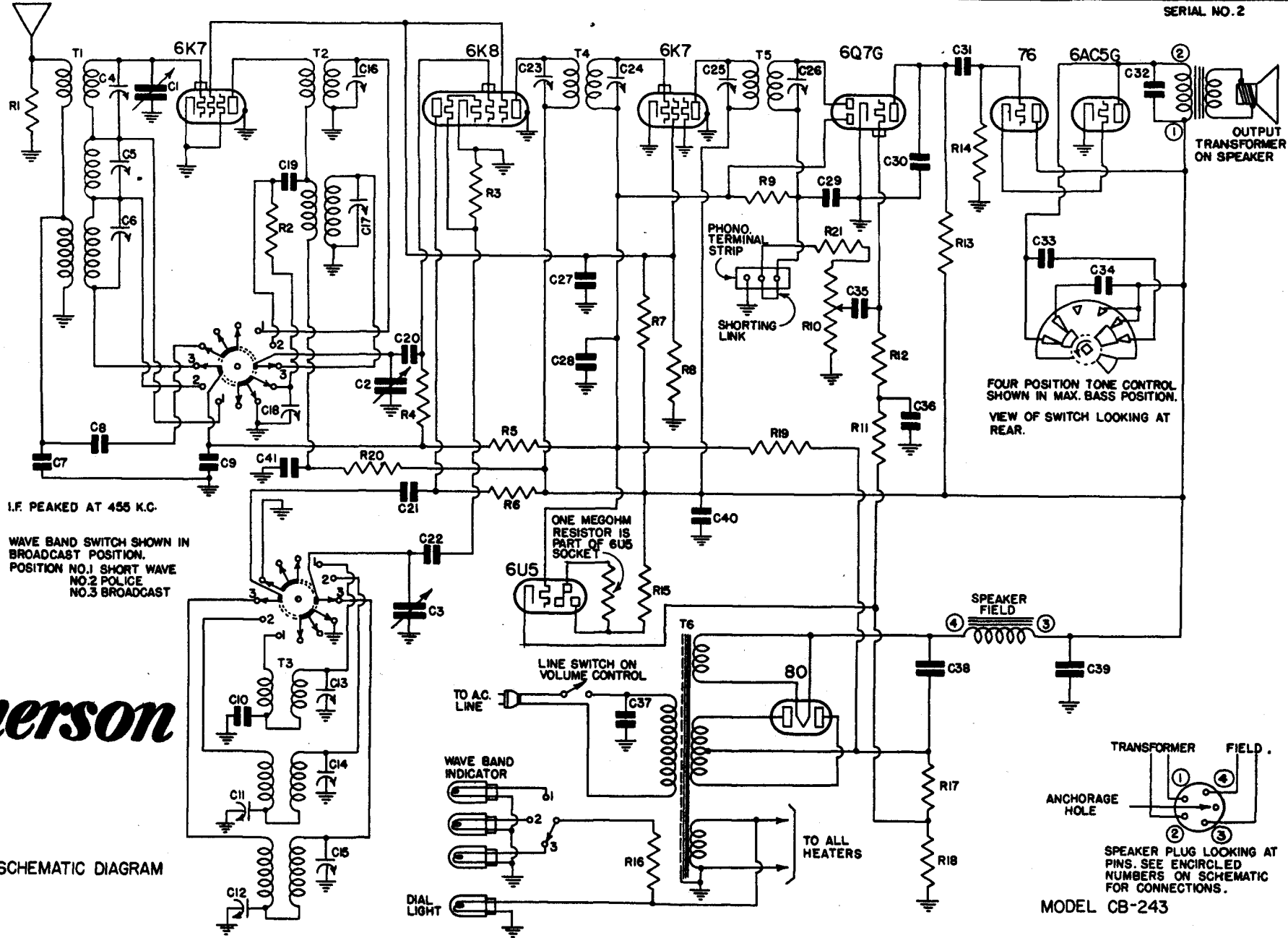

I.F. PEAKED AT 455 K.C.

WAVE BAND SWITCH SHOWN IN BROADCAST POSITION.
POSITION NO.1 SHORT WAVE
NO.2 POLICE
NO.3 BROADCAST

ONE MEGOHM RESISTOR IS PART OF 6U5 SOCKET

FOUR POSITION TONE CONTROL SHOWN IN MAX. BASS POSITION.
VIEW OF SWITCH LOOKING AT REAR.

OUTPUT TRANSFORMER ON SPEAKER

Emerson

SCHEMATIC DIAGRAM

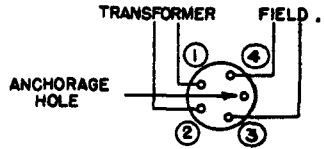

SPEAKER PLUG LOOKING AT PINS. SEE ENCIRCLED NUMBERS ON SCHEMATIC FOR CONNECTIONS.

MODEL CB-243

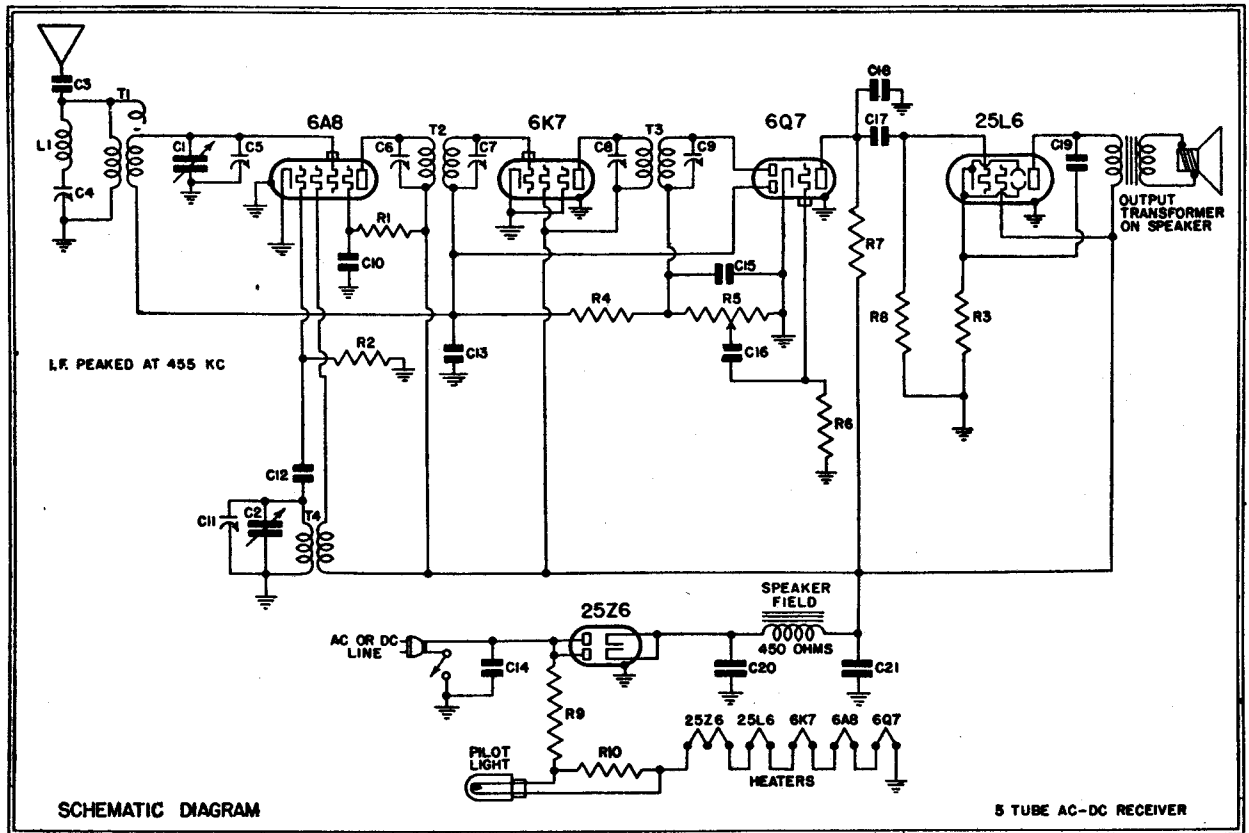

SCHMATIC DIAGRAM FOR MODELS AX-211, 212, 217, 235, 237, 238, 239 and 257

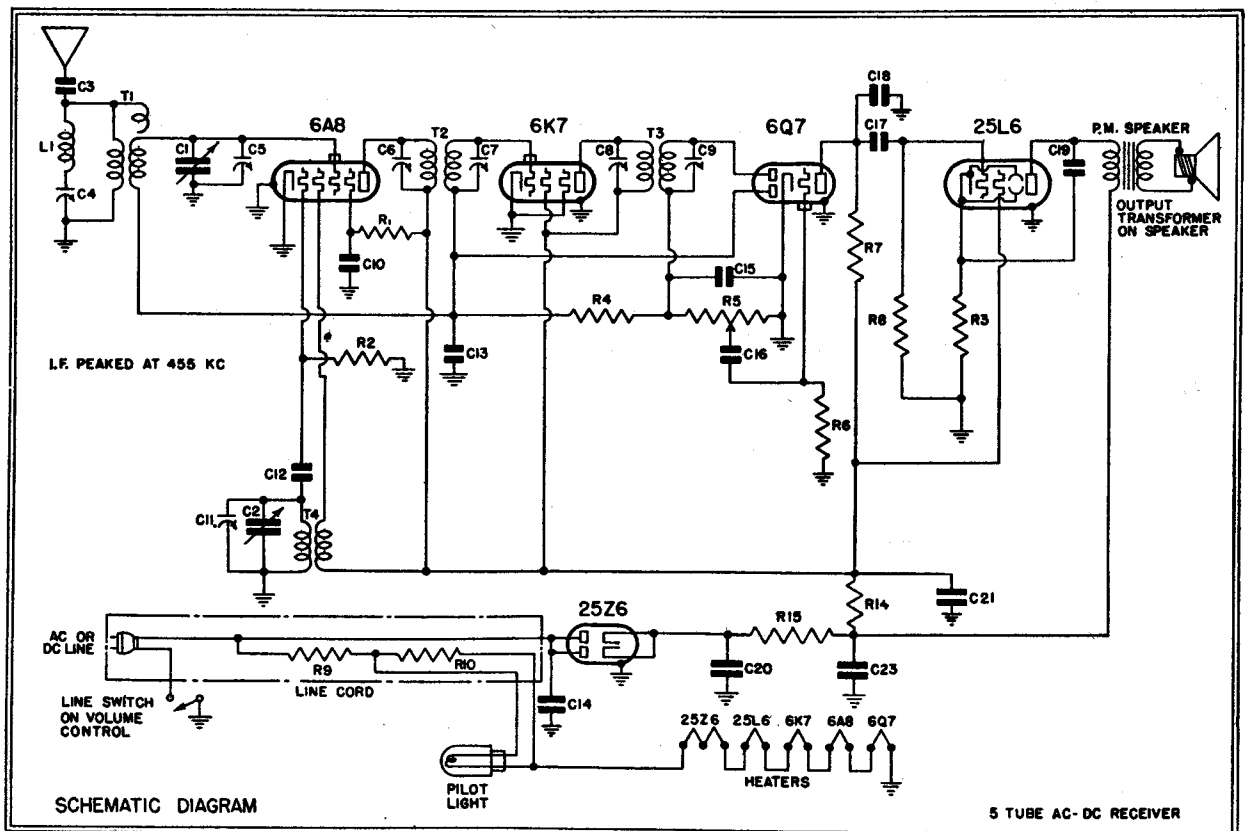

SCHMATIC DIAGRAM FOR MODEL AX-240

Farnsworth

TELEVISION & RADIO CORPORATION

MARION, INDIANA

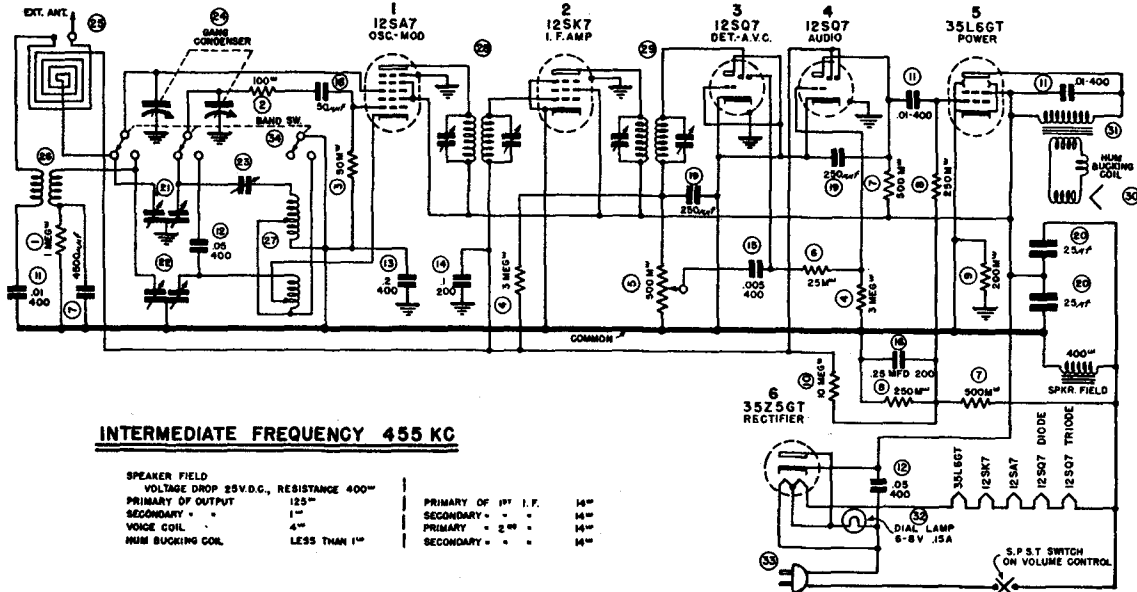

Schematic C5-1.

VOLTAGE	RESISTANCE	VOLTAGE	RESISTANCE	VOLTAGE	RESISTANCE	VOLTAGE	RESISTANCE
1. 0	1. 1 MEG	1. OPEN	1. 1 ME	1. 0	1. 1 MEG	1. 75	1. INF.
2. 0	2. 0	2. 1.5	2. 1.5	2. 1.5	2. 1.5	2. 1.5	2. 1.5
3. 83	3. INF.	3. 75	3. INF.	3. 25↑	3. INF.	3. 80	3. INF.
4. 85	4. 100M	4. 80	4. INF.	4. OPEN	4. INF.	4. 82	4. INF.
5. 39	5. INF.	5. 80	5. INF.	5. 0	5. 500M	5. 1.5↑	5. 1 MEG
6. 80	6. INF.	6. OPEN	6. 800	6. 0	6. 1 ME	6. 5	6. 500
7. 1.5	7. 1.5	7. 0	7. 0	7. 0	7. 0	7. 0	7. 0
8. 0	8. 1ME	8. 1.5	8. 1 ME	8. 0	8. 500M	8. 40	8. INF.
CAP 0		CAP 0		CAP 0		CAP 0	1 MEG

BOTTOM VIEW OF SOCKETS

↑ DEPENDS ON SENSITIVITY OF METER.
RESISTANCE MEASUREMENTS MADE WITH BATTERIES DISCONNECTED.
VOLTAGE & RESISTANCE MEASURED TO GROUND WITH A 1000^Ω PER VOLT VOLTMETER.

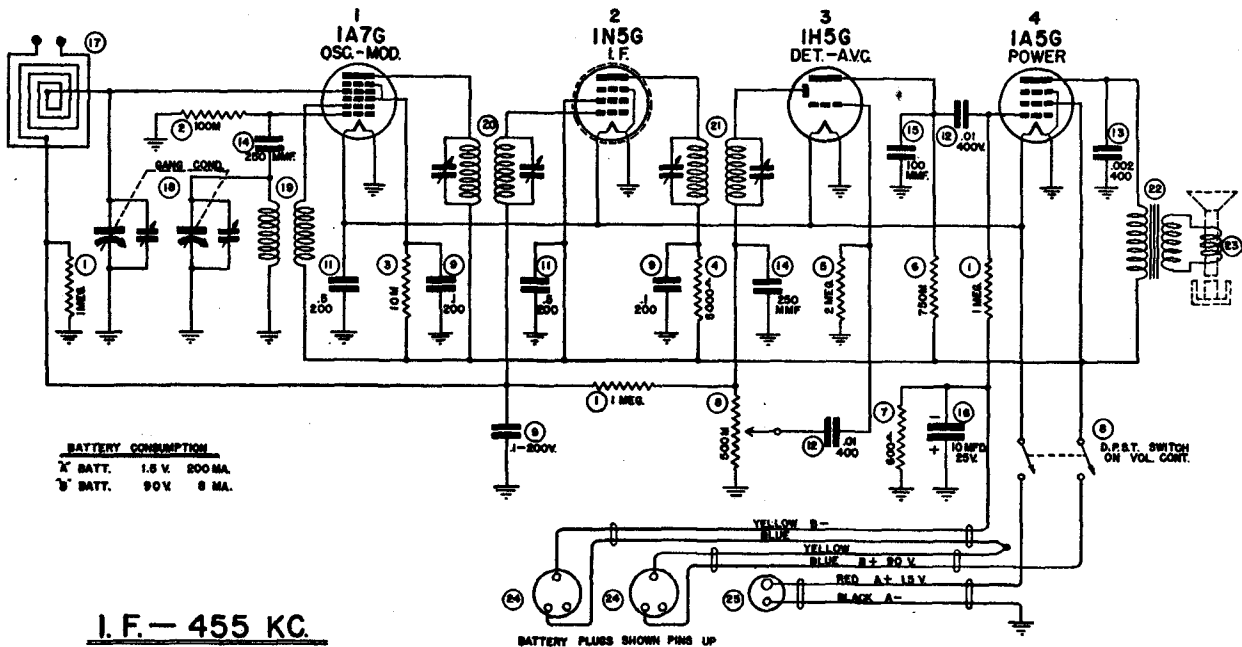

Schematic C6-1.

Farnsworth

TELEVISION & RADIO CORPORATION

MARION, INDIANA

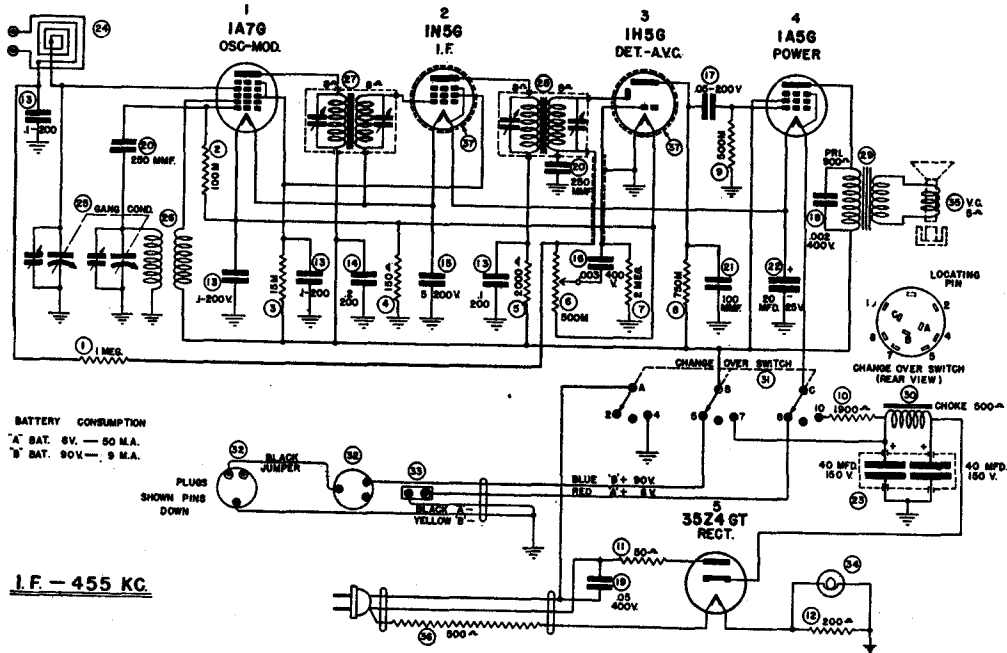

BATTERY CONSUMPTION
 'A' BAT. 6V. — 50 M.A.
 'B' BAT. 90V. — 9 M.A.

I.F. — 455 KC

Schematic C7-1.

VOLTAGE 1 RESISTANCE		VOLTAGE 2 RESISTANCE		VOLTAGE 3 RESISTANCE		VOLTAGE 4 RESISTANCE		VOLTAGE 5 RESISTANCE	
1. 0	1. 0	1. 0	1. 0	1. 0	1. 0	1. INF	1. 120AC	1. 125	
2. 26AC	2. 37	2. 38AC	2. 58	2. 0	2. 38AC	2. 58	2. 120AC	2. 125	
3. 93	3. INF *	3. 93	3. INF *	3. 0	3. 0	3. 85	3. 114AC	3. 122	
4. 93	4. INF *	4. 93	4. INF *	4. 500M	4. 93	4. 93	4. INF *	4. 122	
5. 0	5. 20M	5. 0	5. 0	5. 0	5. 0	5. 500M	5. 114AC	5. 122	
6. 0	6. 0	6. 0	6. 2.5MEG.	6. 40	6. 0	6. INF *	6. 0	6. 125	
7. 13AC	7. 20	7. 28AC	7. 37	7. 13AC	7. 20	7. 95AC	7. 105	7. 105	
8. 0	8. 2.5MEG.	8. 0	8. 0	8. 0	8. 0	8. 150	8. 125DC	8. INF *	

ALL VOLTAGES MEASURED FROM SOCKET TERMINALS TO CHASSIS.
 *RESISTANCE WILL DEPEND ON CONDITION OF ELECTROLYTIC CONDENSER
 VOLTMETER RESISTANCE 1000 OHMS PER VOLT.
 LINE VOLTAGE 117

MEASURE RESISTANCE OF FIELD COIL FROM TERMINAL #4 OF 50L6GT SOCKET TO TERMINAL #8 OF 35Z5GT SOCKET.
 PHONO MOTOR 200Ω MEASURED FROM BLACK LEAD OF MOTOR SWITCH TO GROUND WITH MOTOR SWITCH IN 'OFF' POSITION
 RESISTANCE MEASURED FROM SOCKET TERMINALS TO CHASSIS

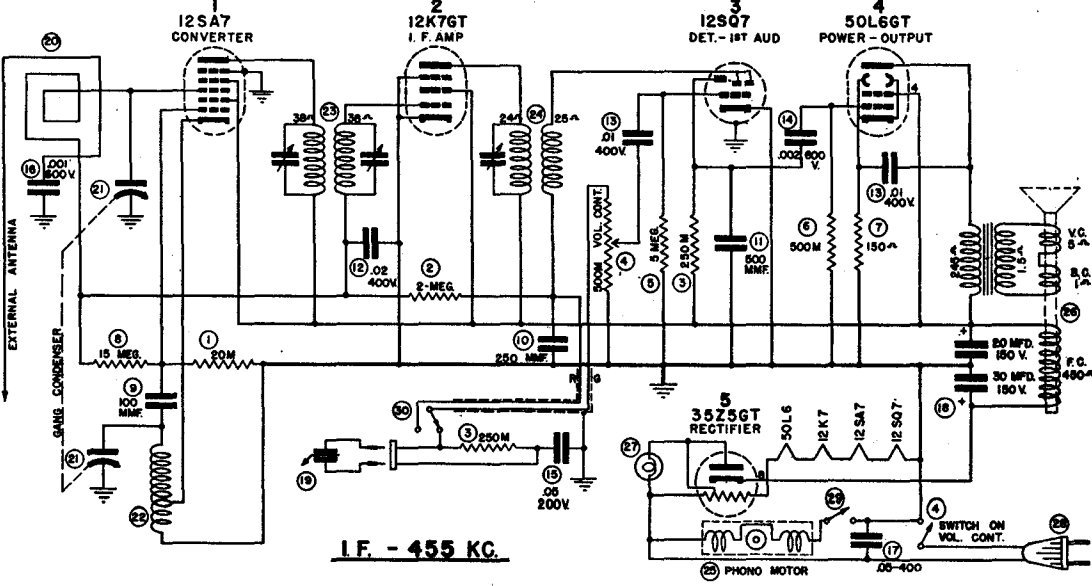

I.F. — 455 KC

Schematic C12

VOLTAGE	1	RESISTANCE	VOLTAGE	2	RESISTANCE	VOLTAGE	3	RESISTANCE	VOLTAGE	4	RESISTANCE	VOLTAGE	5	RESISTANCE	VOLTAGE	6	RESISTANCE	VOLTAGE	7	RESISTANCE	VOLTAGE	8 & 9	RESISTANCE	VOLTAGE	10	RESISTANCE
1.0	1.0	L.O.	1.0	1.0	L.O.	1.0	1.0	L.O.	1.0	1.0	L.O.	1.0	1.0	L.O.	1.0	1.0	L.O.	1.0	1.0	L.O.	1.0	1.0	1.0	1.0	1.0	1.0
2.0	2.0	2.0	2.0	2.0	2.0	2.0	2.0	2.0	2.0	2.0	2.0	2.0	2.0	2.0	2.0	2.0	2.0	2.0	2.0	2.0	2.0	2.0	2.0	2.0	2.0	
3.0	3.0	3.0	3.0	3.0	3.0	3.0	3.0	3.0	3.0	3.0	3.0	3.0	3.0	3.0	3.0	3.0	3.0	3.0	3.0	3.0	3.0	3.0	3.0	3.0	3.0	
4.0	4.0	4.0	4.0	4.0	4.0	4.0	4.0	4.0	4.0	4.0	4.0	4.0	4.0	4.0	4.0	4.0	4.0	4.0	4.0	4.0	4.0	4.0	4.0	4.0	4.0	
5.0	5.0	5.0	5.0	5.0	5.0	5.0	5.0	5.0	5.0	5.0	5.0	5.0	5.0	5.0	5.0	5.0	5.0	5.0	5.0	5.0	5.0	5.0	5.0	5.0	5.0	
6.0	6.0	6.0	6.0	6.0	6.0	6.0	6.0	6.0	6.0	6.0	6.0	6.0	6.0	6.0	6.0	6.0	6.0	6.0	6.0	6.0	6.0	6.0	6.0	6.0	6.0	
7.0	7.0	7.0	7.0	7.0	7.0	7.0	7.0	7.0	7.0	7.0	7.0	7.0	7.0	7.0	7.0	7.0	7.0	7.0	7.0	7.0	7.0	7.0	7.0	7.0	7.0	
8.0	8.0	8.0	8.0	8.0	8.0	8.0	8.0	8.0	8.0	8.0	8.0	8.0	8.0	8.0	8.0	8.0	8.0	8.0	8.0	8.0	8.0	8.0	8.0	8.0	8.0	
9.0	9.0	9.0	9.0	9.0	9.0	9.0	9.0	9.0	9.0	9.0	9.0	9.0	9.0	9.0	9.0	9.0	9.0	9.0	9.0	9.0	9.0	9.0	9.0	9.0	9.0	
10.0	10.0	10.0	10.0	10.0	10.0	10.0	10.0	10.0	10.0	10.0	10.0	10.0	10.0	10.0	10.0	10.0	10.0	10.0	10.0	10.0	10.0	10.0	10.0	10.0	10.0	

† - VOLTAGE READING WILL VARY WITH SENSITIVITY OF METERS.
 * - RESISTANCE WILL DEPEND ON CONDITION OF ELECTROLYTIC CONDENSER.

BOTTOM VIEW OF SOCKETS

LINE VOLTAGE = 110.
 RECTIFIER FILAMENT VOLTAGE 5 V.A.C.
 MEASURED FROM PIN 2 TO PIN 8 OF SOCKET #10.

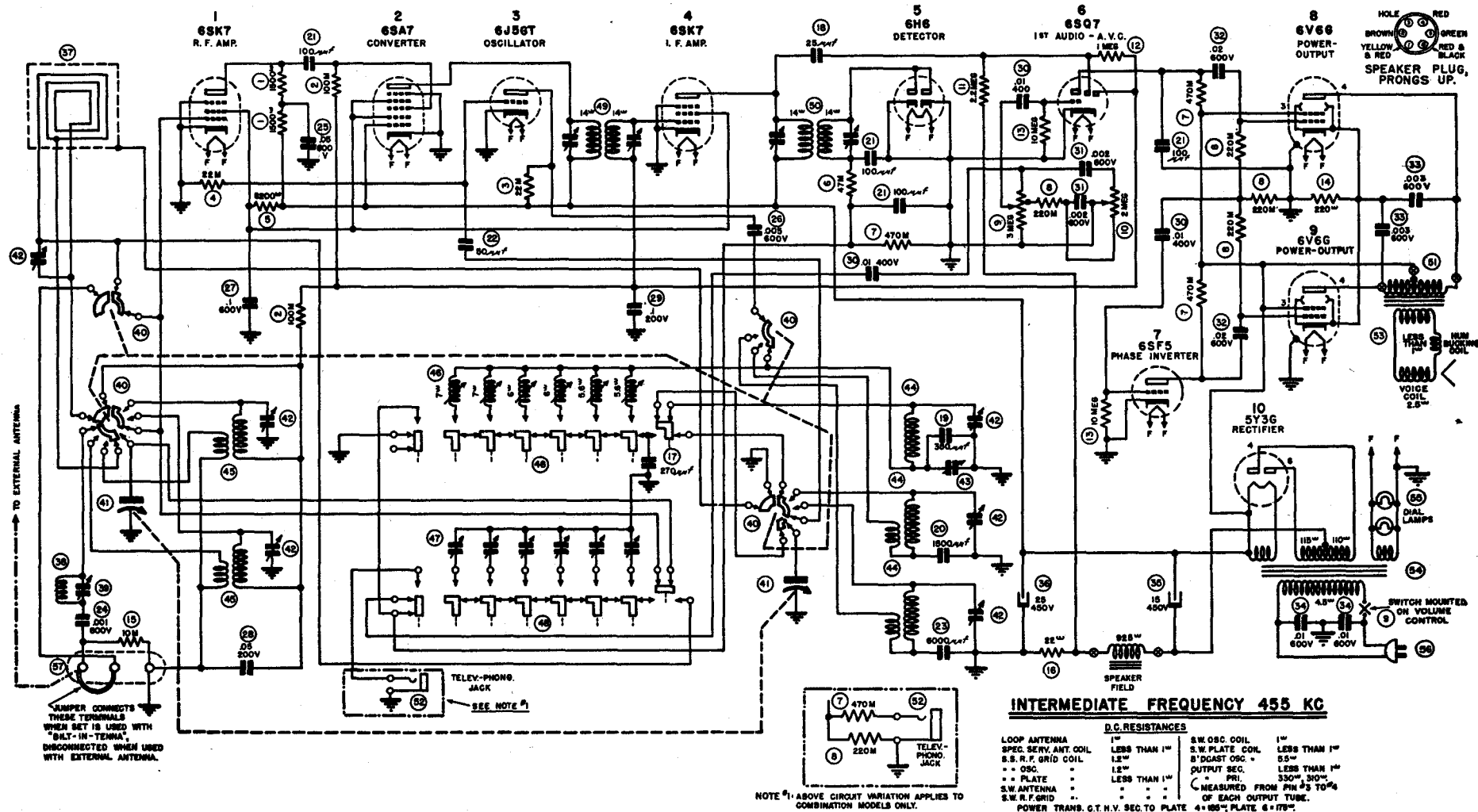

INTERMEDIATE FREQUENCY 455 KC

	D.C. RESISTANCES		
LOOP ANTENNA	1"	S.W. OSC. COIL	1"
SPEC. SERV. ANT. COIL	LESS THAN 1"	S.W. PLATE COIL	LESS THAN 1"
S.S. R.F. GRID COIL	1.2"	B'D'GAST OSC	55"
OSC.	1.2"	OUTPUT SEC.	LESS THAN 1"
PLATE	LESS THAN 1"	PRI.	330" 30%
S.W. ANTENNA	...	MEASURED FROM PINS 10 TO 4	
S.W. R.F. GRID	...	OF EACH OUTPUT TUBE.	
		POWER TRANS. C.T.N.V. SEC. TO PLATE	4 * 100% PLATE 6 * 170"

NOTE #1 - ABOVE CIRCUIT VARIATION APPLIES TO COMBINATION MODELS ONLY.

Farnsworth

Schematic C4-1 and C4-2

VOLTAGE	1	RESISTANCE	VOLTAGE	2	RESISTANCE	VOLTAGE	3	RESISTANCE	VOLTAGE	4	RESISTANCE	VOLTAGE	5	RESISTANCE	VOLTAGE	6	RESISTANCE	VOLTAGE	7	RESISTANCE	VOLTAGE	8	RESISTANCE	
1.0	1.0	1.0	1.0	1.0	1.0	1.0	1.0	1.0	1.0	1.0	1.0	1.0	1.0	1.0	1.0	1.0	1.0	1.0	1.0	1.0	1.0	1.0	1.0	1.0
2.0	2.0	2.0	2.0	2.0	2.0	2.0	2.0	2.0	2.0	2.0	2.0	2.0	2.0	2.0	2.0	2.0	2.0	2.0	2.0	2.0	2.0	2.0	2.0	2.0
3.0	3.0	3.0	3.0	3.0	3.0	3.0	3.0	3.0	3.0	3.0	3.0	3.0	3.0	3.0	3.0	3.0	3.0	3.0	3.0	3.0	3.0	3.0	3.0	3.0
4.0	4.0	4.0	4.0	4.0	4.0	4.0	4.0	4.0	4.0	4.0	4.0	4.0	4.0	4.0	4.0	4.0	4.0	4.0	4.0	4.0	4.0	4.0	4.0	4.0
5.0	5.0	5.0	5.0	5.0	5.0	5.0	5.0	5.0	5.0	5.0	5.0	5.0	5.0	5.0	5.0	5.0	5.0	5.0	5.0	5.0	5.0	5.0	5.0	5.0
6.0	6.0	6.0	6.0	6.0	6.0	6.0	6.0	6.0	6.0	6.0	6.0	6.0	6.0	6.0	6.0	6.0	6.0	6.0	6.0	6.0	6.0	6.0	6.0	6.0
7.0	7.0	7.0	7.0	7.0	7.0	7.0	7.0	7.0	7.0	7.0	7.0	7.0	7.0	7.0	7.0	7.0	7.0	7.0	7.0	7.0	7.0	7.0	7.0	7.0
8.0	8.0	8.0	8.0	8.0	8.0	8.0	8.0	8.0	8.0	8.0	8.0	8.0	8.0	8.0	8.0	8.0	8.0	8.0	8.0	8.0	8.0	8.0	8.0	8.0
2.0AC	2.0AC	2.0AC	2.0AC	2.0AC	2.0AC	2.0AC	2.0AC	2.0AC	2.0AC	2.0AC	2.0AC	2.0AC	2.0AC	2.0AC	2.0AC	2.0AC	2.0AC	2.0AC	2.0AC	2.0AC	2.0AC	2.0AC	2.0AC	2.0AC
2.205	2.205	2.205	2.205	2.205	2.205	2.205	2.205	2.205	2.205	2.205	2.205	2.205	2.205	2.205	2.205	2.205	2.205	2.205	2.205	2.205	2.205	2.205	2.205	2.205
4.4MEG	4.4MEG	4.4MEG	4.4MEG	4.4MEG	4.4MEG	4.4MEG	4.4MEG	4.4MEG	4.4MEG	4.4MEG	4.4MEG	4.4MEG	4.4MEG	4.4MEG	4.4MEG	4.4MEG	4.4MEG	4.4MEG	4.4MEG	4.4MEG	4.4MEG	4.4MEG	4.4MEG	4.4MEG
5.0	5.0	5.0	5.0	5.0	5.0	5.0	5.0	5.0	5.0	5.0	5.0	5.0	5.0	5.0	5.0	5.0	5.0	5.0	5.0	5.0	5.0	5.0	5.0	5.0
6.1NF	6.1NF	6.1NF	6.1NF	6.1NF	6.1NF	6.1NF	6.1NF	6.1NF	6.1NF	6.1NF	6.1NF	6.1NF	6.1NF	6.1NF	6.1NF	6.1NF	6.1NF	6.1NF	6.1NF	6.1NF	6.1NF	6.1NF	6.1NF	6.1NF
6.3AC	6.3AC	6.3AC	6.3AC	6.3AC	6.3AC	6.3AC	6.3AC	6.3AC	6.3AC	6.3AC	6.3AC	6.3AC	6.3AC	6.3AC	6.3AC	6.3AC	6.3AC	6.3AC	6.3AC	6.3AC	6.3AC	6.3AC	6.3AC	6.3AC
6.170	6.170	6.170	6.170	6.170	6.170	6.170	6.170	6.170	6.170	6.170	6.170	6.170	6.170	6.170	6.170	6.170	6.170	6.170	6.170	6.170	6.170	6.170	6.170	6.170
+	+	+	+	+	+	+	+	+	+	+	+	+	+	+	+	+	+	+	+	+	+	+	+	+

+ - VOLTAGE READING WILL VARY WITH SENSITIVITY OF METER.

+ - RECTIFIER FILAMENT VOLTAGE 5 VOLT A.C. PIN 2 TO PIN 8.

* - RESISTANCE WILL DEPEND ON CONDITION OF ELECTROLYTIC CONDENSER.

BOTTOM VIEW OF SOCKETS

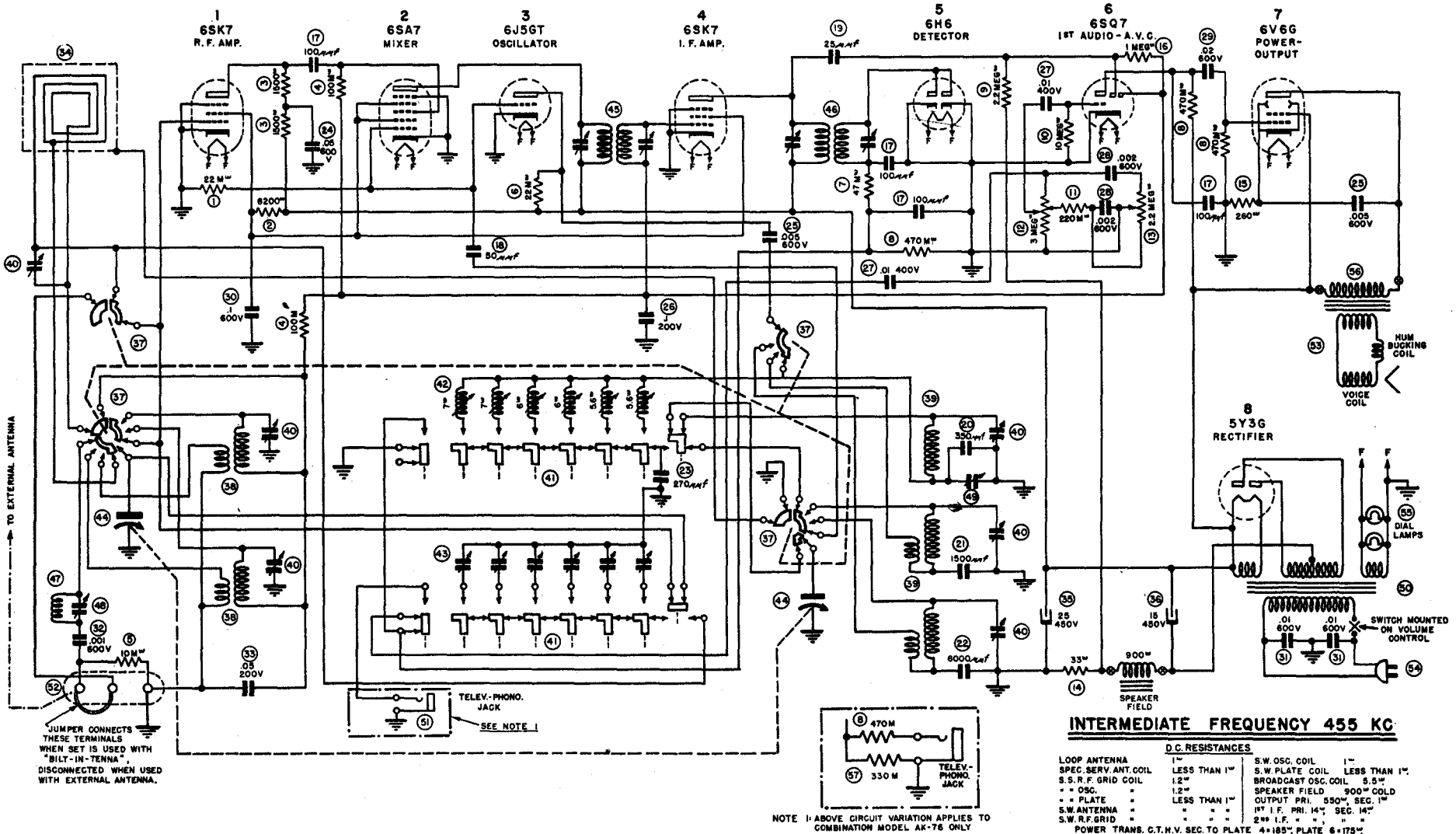

VOLTAGE	RESISTANCE	VOLTAGE	RESISTANCE	VOLTAGE	RESISTANCE	VOLTAGE	RESISTANCE	VOLTAGE	RESISTANCE	VOLTAGE	RESISTANCE	VOLTAGE	RESISTANCE
1 0	1 INF	1 0	1 0	1 0	1 INF	1 0	1 INF	1 0	1 INF	1 0	1 INF	1 0	1 INF
2 17AC	2 INF	2 17AC	2 INF	2 23.5AC	2 INF	2 0	2 INF	2 0	2 10MEG*	2 53AC	2 INF	2 78AC	2 INF
3 0	3 0	3 85	3 0	3 0	3 0	3 0	3 0	3 0	3 94	3 94	3 INF *	3 0	3 0
4 0	4 3 MEG*	4 85	4 INF *	4 0	4 3 MEG*	4 0	4 0	4 0	4 3 MEG*	4 100	4 INF *	4 103AC	4 INF *
5 2.4	5 180	5 0	5 50 M*	5 0	5 0	5 0	5 0	5 0	5 3 MEG*	5 0	5 500M	5 103AC	5 INF *
6 55	6 INF *	6 75	6 INF *	6 87	6 INF	6 0	6 0	6 0	6 INF *	6 0	6 0	6 103AC	6 INF *
7 23.5AC	7 INF *	7 1AC	7 INF	7 28.5AC	7 INF	7 6.2AC	7 INF	7 6.2AC	7 INF *	7 28.5AC	7 INF	7 53AC	7 INF *
8 85	8 INF *	8 2.4	8 3MEG	8 95	8 INF	8 0	8 0	8 0	8 INF	8 6.8	8 150M	8 200	8 INF *

† VOLTAGE READING WILL VARY WITH SENSITIVITY OF METER.
 * RESISTANCE WILL DEPEND ON CONDITION OF ELECTROLYTIC CONDENSER.

BOTTOM VIEW OF SOCKETS

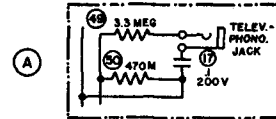

NOTE: 1- CONNECTION #1 ON ALL SOCKETS CONNECTED TO CHASSIS.
 2- CONNECTION #2 ON SOCKET 4 IS REFERENCE POINT FOR A.C. FILAMENT VOLTAGES.

NOTE 4: ABOVE CIRCUIT CHANGE APPLIES TO COMBINATION MODELS AK-58 & AK-59 WHEN STAMPED (2)

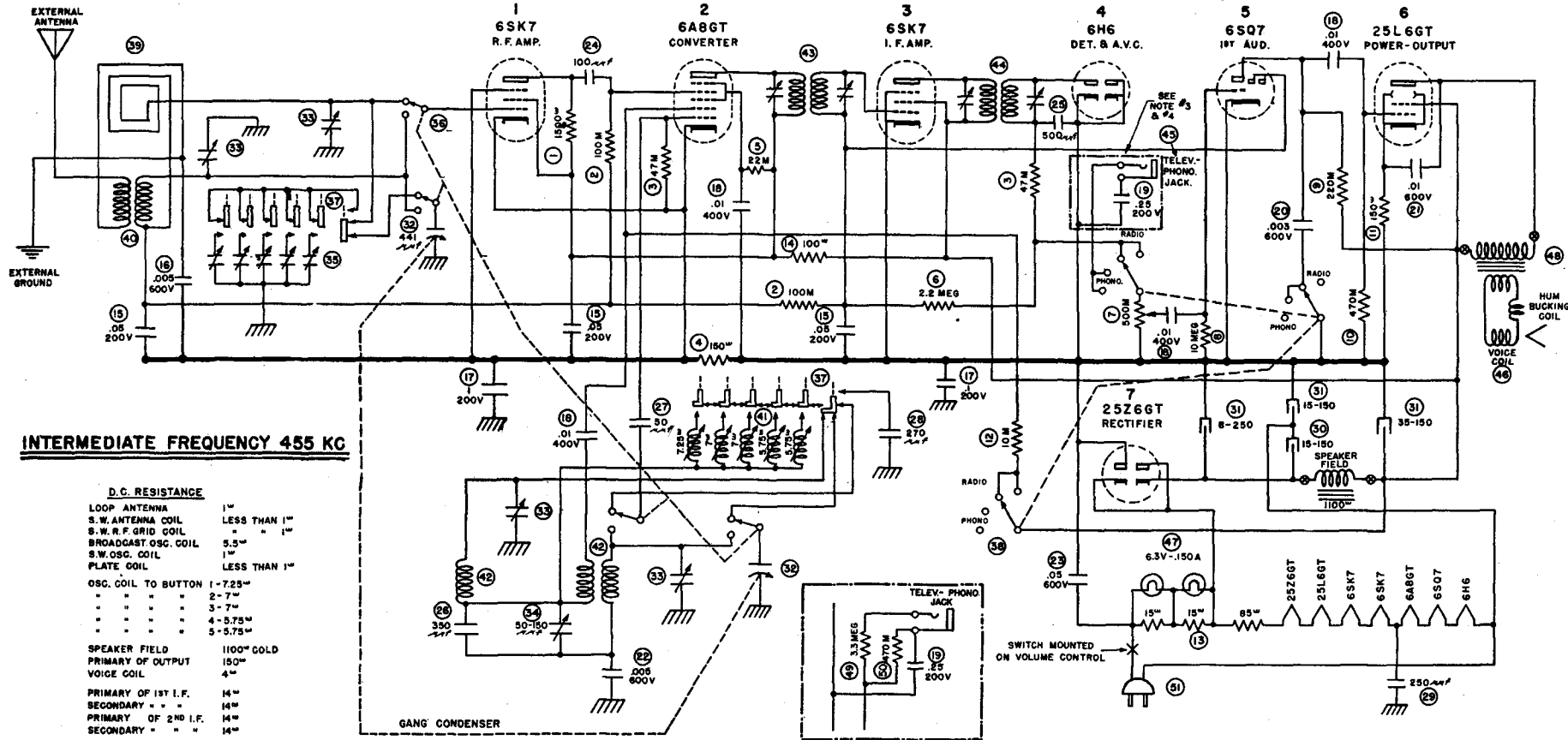

INTERMEDIATE FREQUENCY 455 KC

D.C. RESISTANCE

LOOP ANTENNA	1"
S.W. ANTENNA COIL	LESS THAN 1"
S.W. R.F. GRID COIL	" "
BROADCAST OSC. COIL	5.5"
S.W. OSC. COIL	1"
PLATE COIL	LESS THAN 1"
OSC. COIL TO BUTTON	1-7.25"
" " " "	2-7"
" " " "	3-7"
" " " "	4-5.75"
" " " "	5-5.75"
SPEAKER FIELD	1100" GOLD
PRIMARY OF OUTPUT VOICE COIL	150"
SECONDARY " " "	4"
PRIMARY OF 1ST I.F.	14"
SECONDARY " " "	14"
PRIMARY OF 2ND I.F.	14"
SECONDARY " " "	14"

NOTE: 3- ABOVE CIRCUIT CHANGE APPLIES TO COMBINATION MODELS AK-58 & AK-59 ONLY.

Schematic C2-1, C2-2, C2-3 and C2-4



SERVICE NOTES RLCS-648W

GENERAL ELECTRIC

SIX-TUBE, SINGLE BAND
AUTOMATIC PHONOGRAPH COMBINATION

MODEL LC-648W

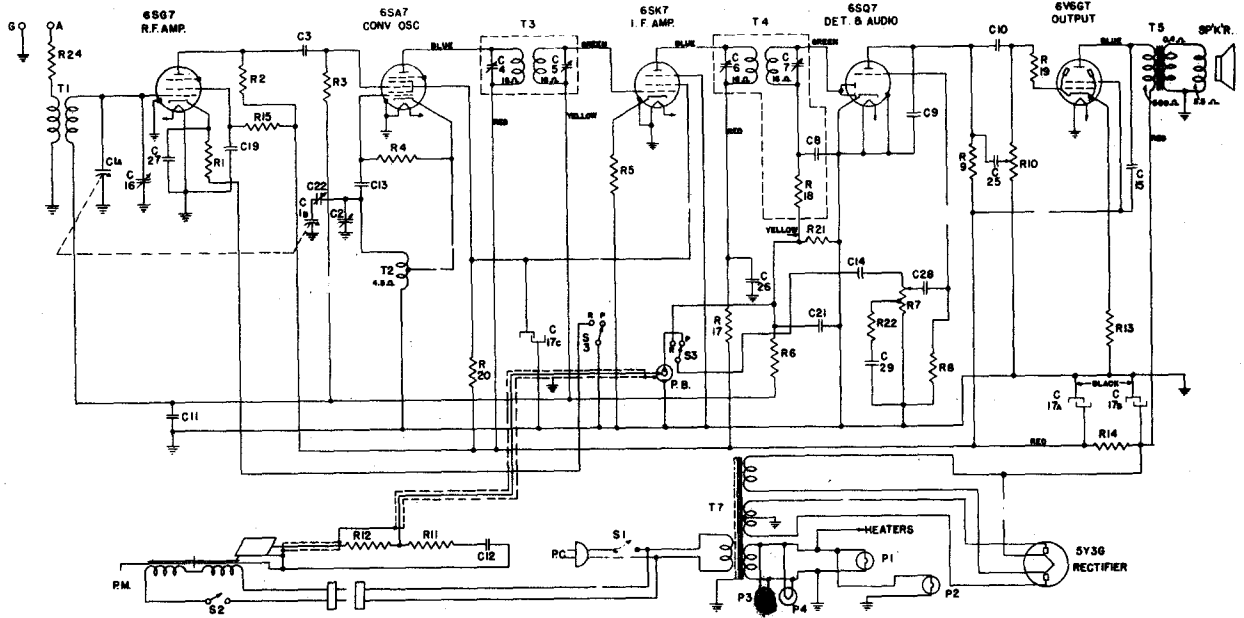

SERVICE NOTES RLS-916

GENERAL ELECTRIC

Nine-tube Superheterodyne

MODELS L915W & L916

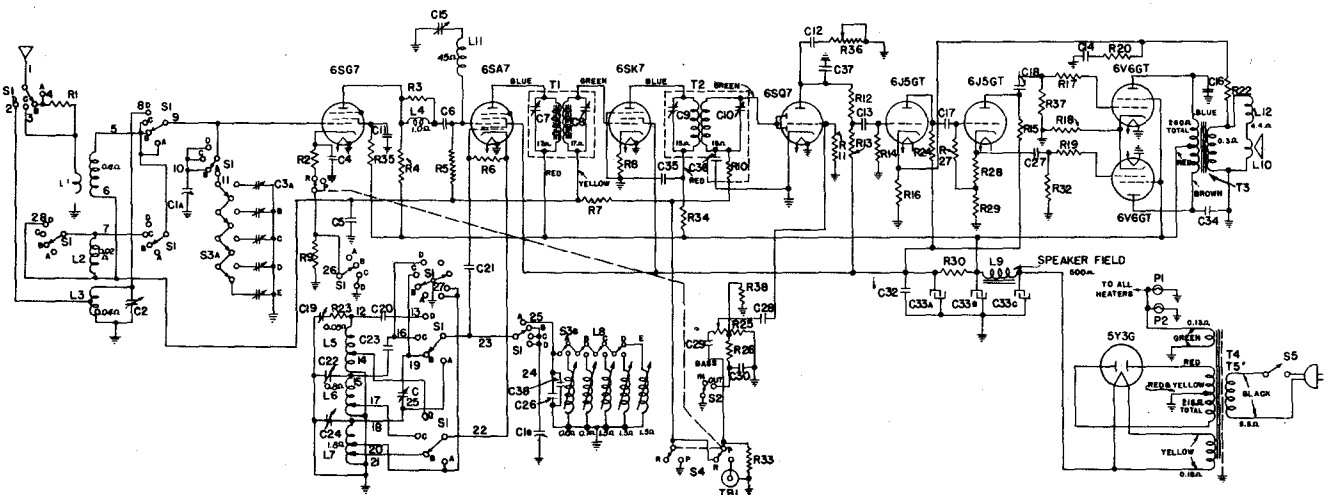
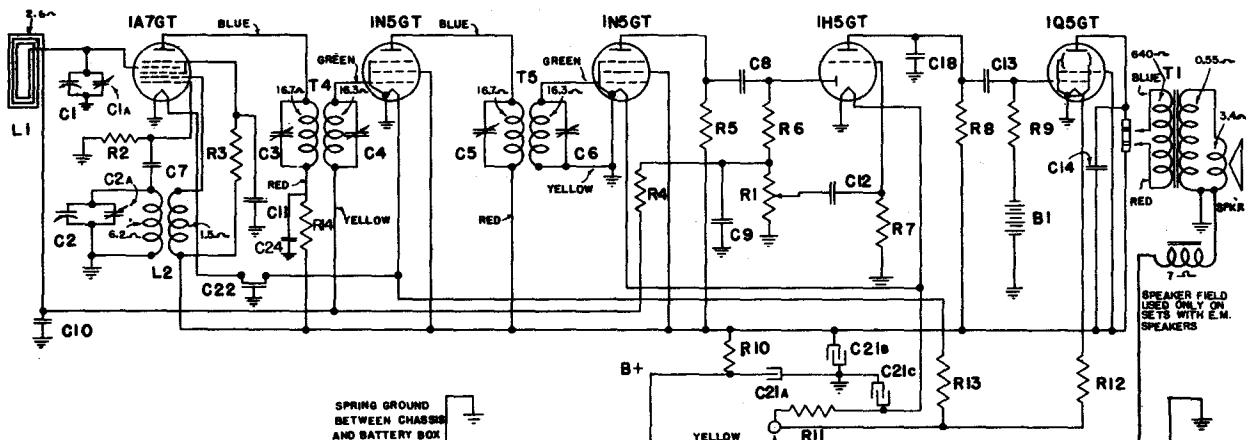

Fig. 1. Schematic Diagram

GENERAL ELECTRIC

SELF-CHARGING PORTABLE RADIO

MODEL LB-530X



POWER SELECTOR SWITCH OPERATION

POSITION	CONTACTS CONNECTED
"OFF"	ALL CONTACTS OPEN
"BATTERY"	#1 to #2; #4 to #5; #7* to #8
"AC"	#1 to #2 to #3; #4 to #5; #8 to #9
"CHARGE"	#2 to #3; #8 to #9

* #7 terminal is not connected to circuit

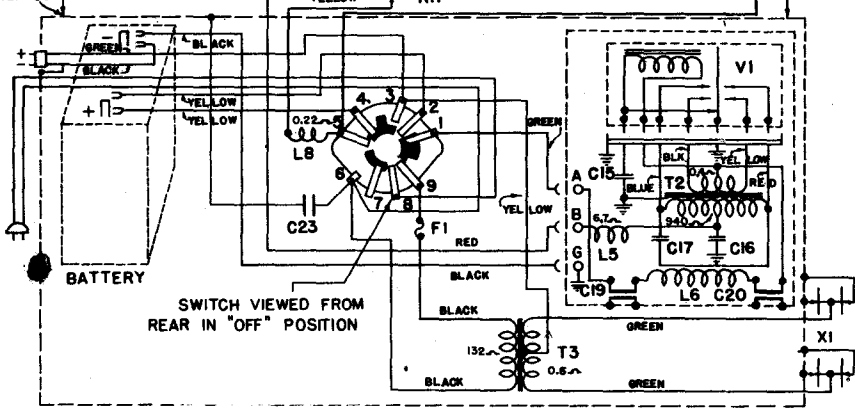

GENERAL ELECTRIC

Nine-tube Superheterodyne

MODEL L-915

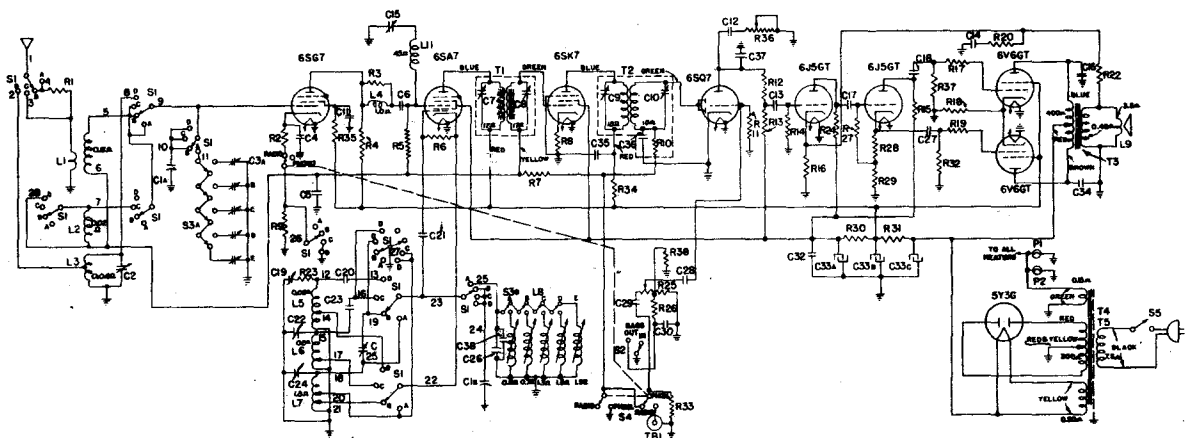
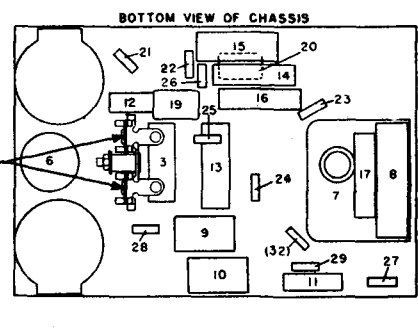
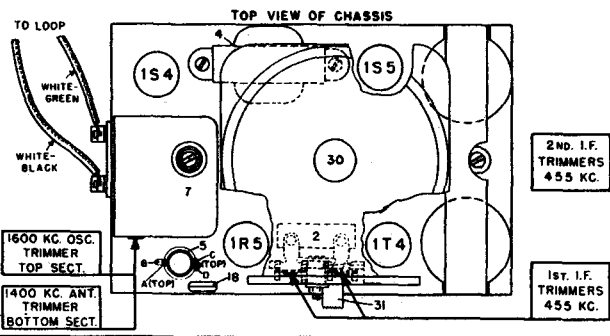
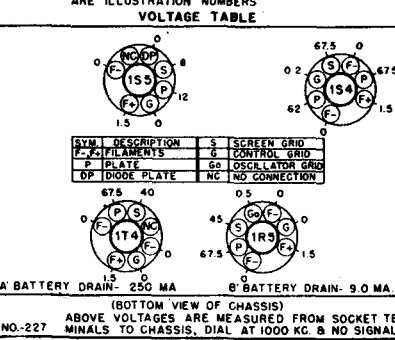
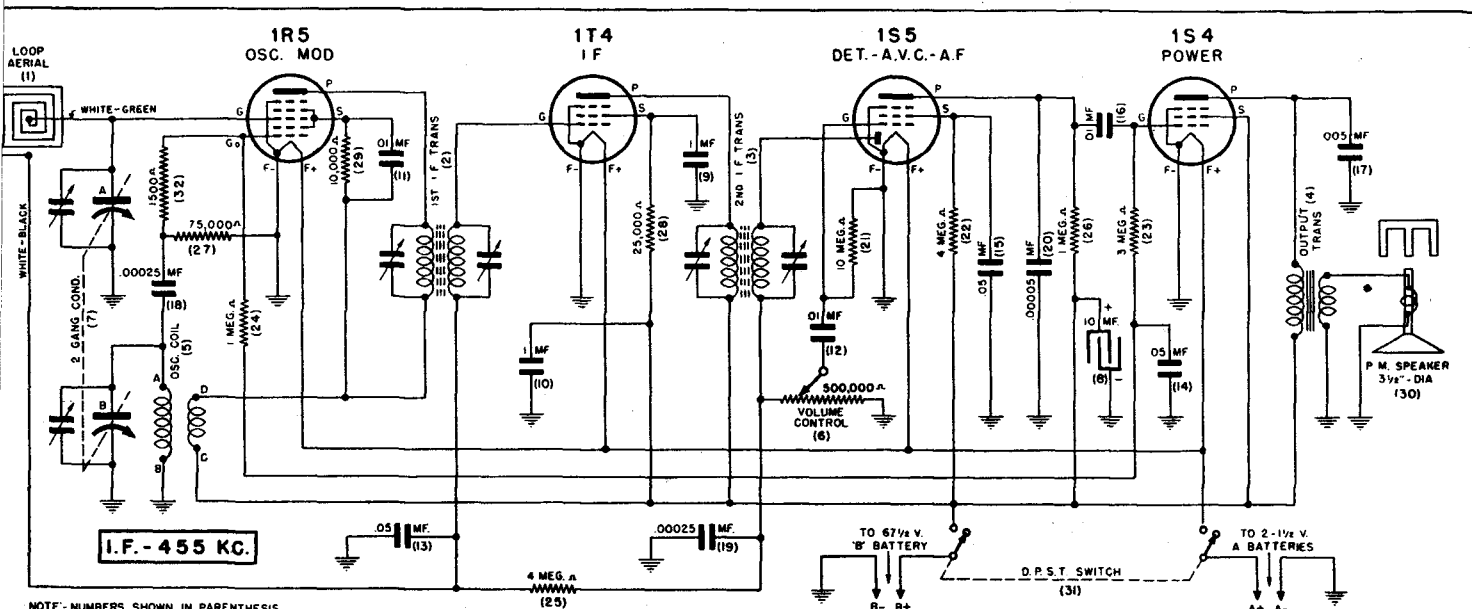

Fig. 1. Schematic Diagram

GENERAL ELECTRIC

**BATTERY OPERATED PORTABLE
SUPERHETERODYNE RADIO**

MODEL LB-412



BROADCAST AC-DC RECEIVERS

MODELS L-540, L-541, L-542, L-543, L-542M, L-543M, L-580

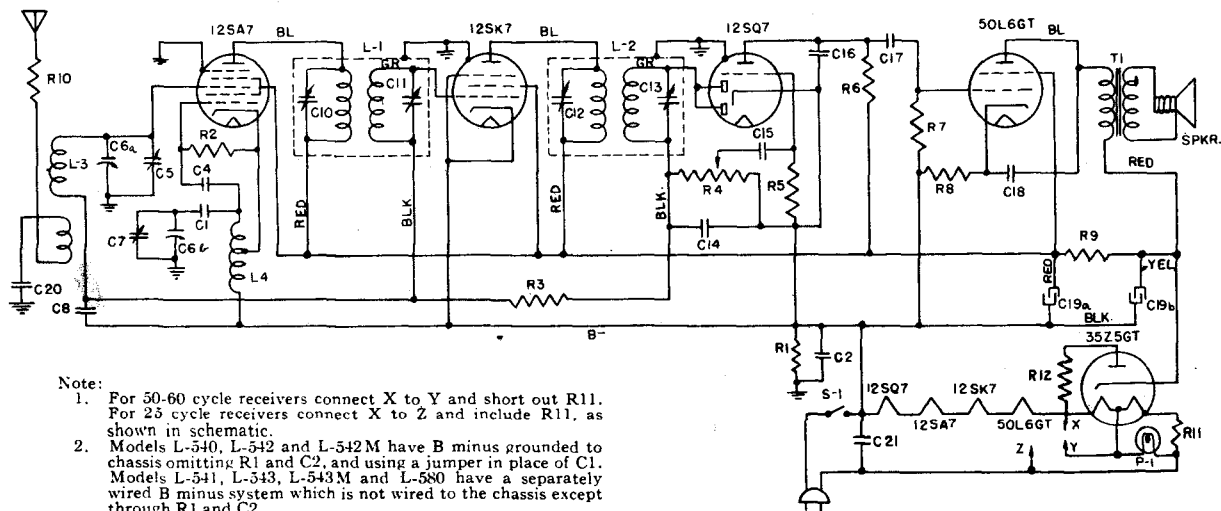

- Note:**
- For 50-60 cycle receivers connect X to Y and short out R11. For 25 cycle receivers connect X to Z and include R11, as shown in schematic.
 - Models L-540, L-542 and L-542M have B minus grounded to chassis omitting R1 and C2, and using a jumper in place of C1. Models L-541, L-543, L-543M and L-580 have a separately wired B minus system which is not wired to the chassis except through R1 and C2.

GENERAL ELECTRIC

SEVEN-TUBE, THREE-BAND PHONOGRAPH COMBINATION MODEL LC-758

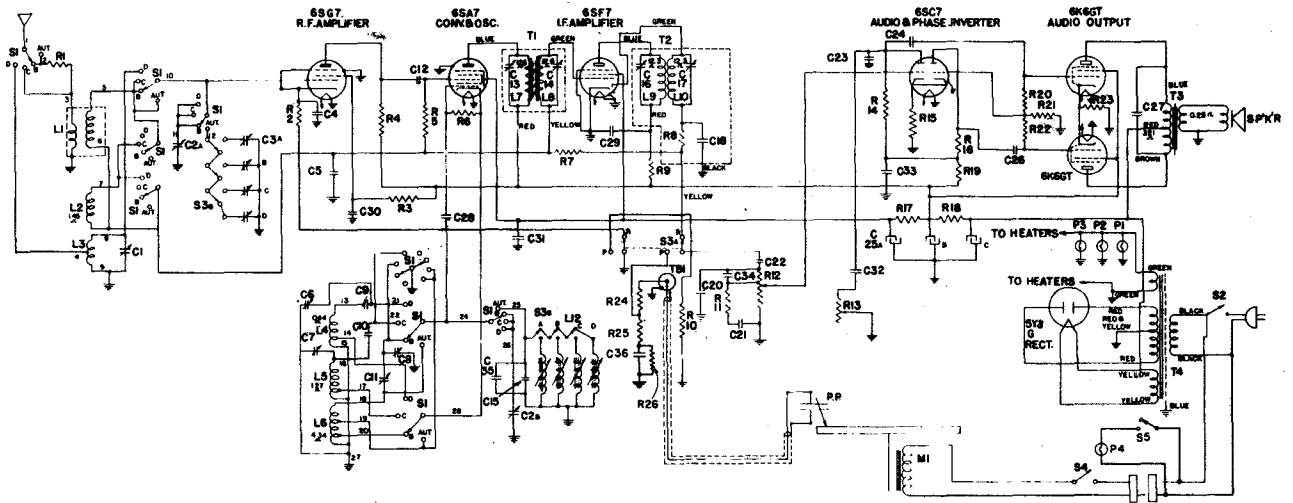

6 Tube AC Superheterodyne RADIO-PHONO COMBINATION AUTOMATIC RECORD CHANGER

Frequency Range 540-1630 Kilocycles
MODEL LC-608

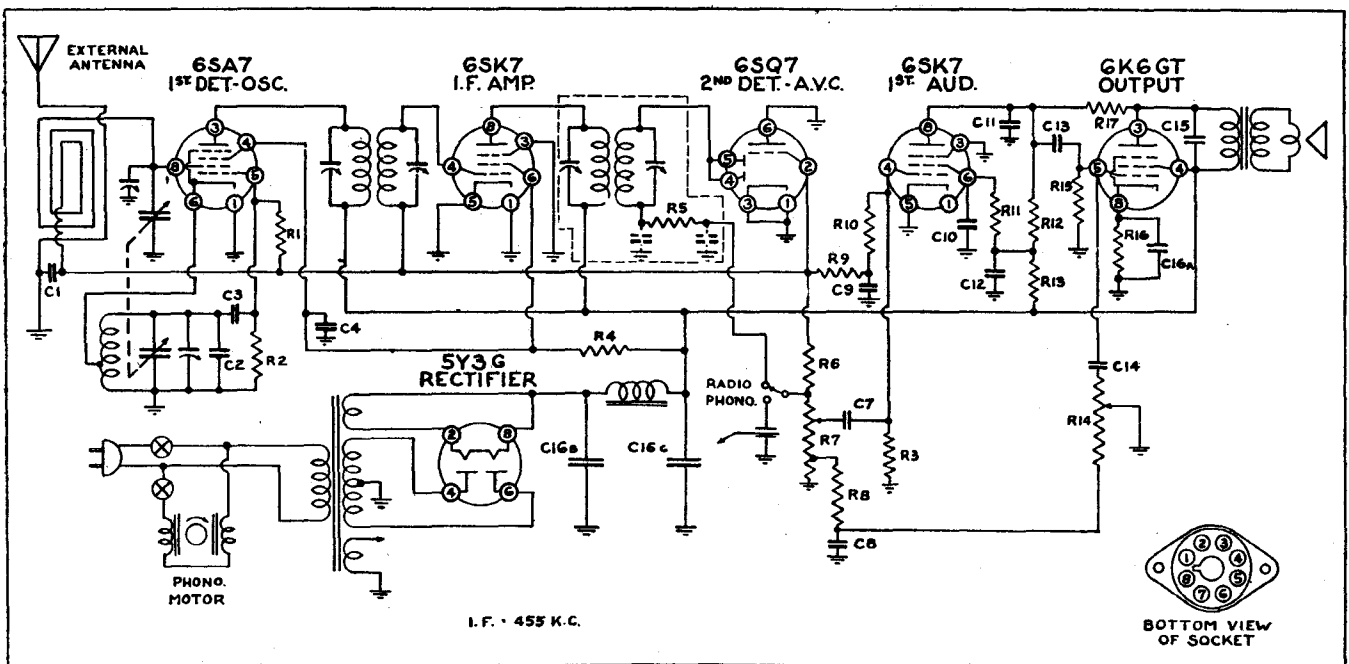

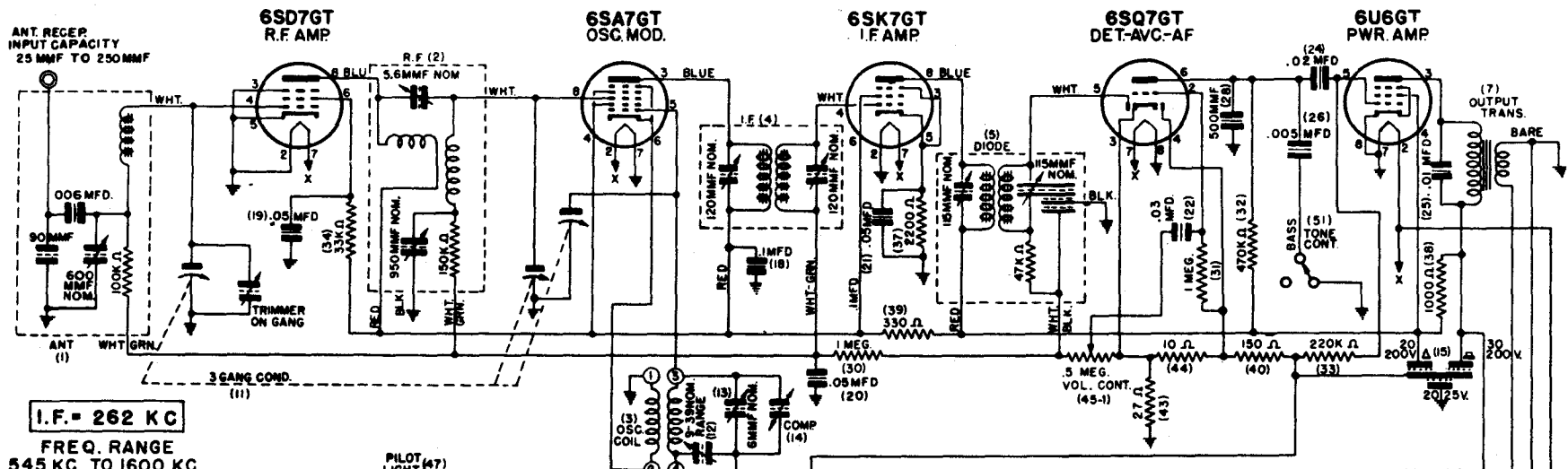

I.F. = 262 KC
FREQ. RANGE
545 KC TO 1600 KC

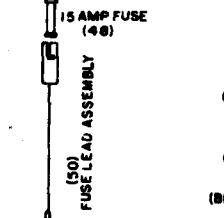
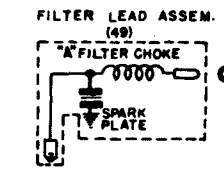

NOTE:
 ALL VOLTAGES MEASURED ON A 1000 OHM PER VOLT VOLTMETER

VOLTAGE CHART				
TUBE	PLATE TO GND.	SCREEN TO GND.	CATH. TO GND.	0
6SD7GT R.F. AMP	115 V.	70 V.	0	
6SA7GT OSC. MOD.	115 V.	115 V.	0	
6SK7GT I.F. AMP	120 V.	118 V.	7 V.	
6SQ7GT DET. AVC. A.F.	35 V.	—	-2.5 V.	
6U6GT P.W.R. AMP	145 V.	120 V.	0	
6X5GT RECT.	A. C.	—	148 V.	

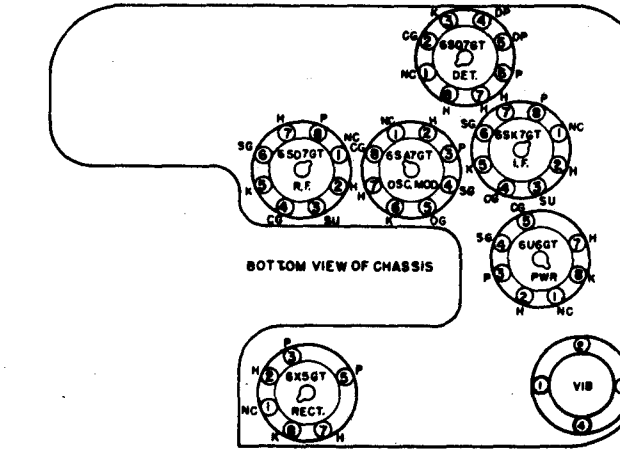
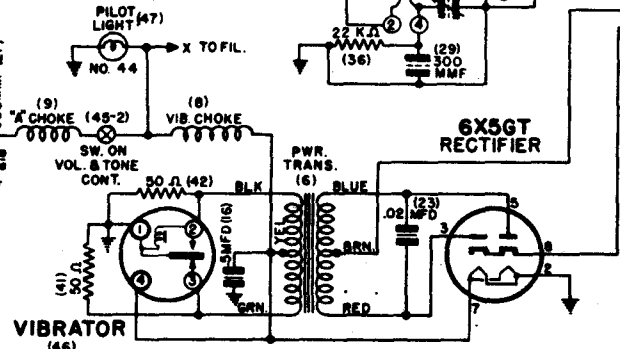

Motorola

Model 43-H

DIAG. NO.	PART NO.	DESCRIPTION	DIAG. NO.	PART NO.	DESCRIPTION
1	1X23107	ANTENNA COIL & SHIELD ASSEMBLY	27	2186500	MOLDED MICA COND. (.500 MFD.) 20%
2	1X23098	R.F. COIL & SHIELD ASSEMBLY	28	2185500	MOLDED MICA COND. (.300 MFD.) 20%
3	1X23113	OSC. COIL & LEADS ASSEMBLY	29	21A23110	CERAMIC MICA COND. (.300 MFD.) 5%
4	1X23096	I.F. COIL & SHIELD ASSEMBLY	30	686159	CARBON RESISTOR (1.0 MEG.-1/3-20) INS.
5	1X2309L	DIODE COIL & SHIELD ASSEMBLY	31	686159	CARBON RESISTOR (1.0 MEG.-1/3-20) INS.
6	25B23103	POWER TRANSFORMER	32	686160	CARBON RESISTOR (170,000-1/3-20) INS.
7	25A23059	OUTPUT TRANSFORMER	33	686204	CARBON RESISTOR (220,000-1/3-20) INS.
8	21A17010	VIBRATOR CHOKER	34	686012	CARBON RESISTOR (33,000-1/2-20) INS.
9	21A23092	*A* CHOKER & BRACKET			
10	50B2340L	SPEAKER (6" ELECTRO)	36	686212	CARBON RESISTOR (22,000-1/3-20) INS.
11	1X23289	TUNING UNIT, GANG & FULLY ASSEMBLY	37	686210	CARBON RESISTOR (2200-1/3-20) INS.
12	20A23135	OSC. PADDER & BRACKET (9-39 MFD.)	38	686184	CARBON RESISTOR (1000-1-20) N.I.
13	20A17237	TRIMMER & BRACKET (6 MFD.)	39	686010	CARBON RESISTOR (330-1/2-20) INS.
14	20A23827	COMPENSATING CONDENSER	40	686330	CARBON RESISTOR (150-1-10) INS.
15	23A22730	ELECT. COND. (50-20/200V.-20/25V.)	41	686005	CARBON RESISTOR (50-1/2-20) N.I.
16	8A19133	TUBULAR CONDENSER (.5-100V.)	42	686005	CARBON RESISTOR (50-1/2-20) N.I.
17	8A11095	TUBULAR CONDENSER (.4-100V.)	43	686331	CARBON RESISTOR (27-1/3-10) INS.
18	8A3310	TUBULAR CONDENSER (.1-200V.)	44	686352	CARBON RESISTOR (10-1/3-10) INS.
19	8A23116	TUBULAR CONDENSER (.05-200V.)	45	18B23128	VOL. CONT., SWITCH & GEAR (.5 MEG.)
20	8A13514	TUBULAR CONDENSER (.05-100V.)	46	18A5067	VIBRATOR
21	8A13514	TUBULAR CONDENSER (.05-100V.)	47	65X10867	BULB (BLUE BEAD) #4
22	8A3303	TUBULAR CONDENSER (.03-100V.)	48	65X1165	FUSE (15 AMP.) 3AG
23	8A22760	TUBULAR CONDENSER (.02-100V.)	49	1X23387	FILTER LEAD ASSEMBLY
24	8A12699	TUBULAR CONDENSER (.02-100V.)	50	1X23408	FUSE LEAD ASSEMBLY
25	8A10279	TUBULAR CONDENSER (.01-100V.)	51	1X23243	PUSH SWITCH (TONE CONTROL)
26	8A18580	TUBULAR CONDENSER (.005-600V.)			

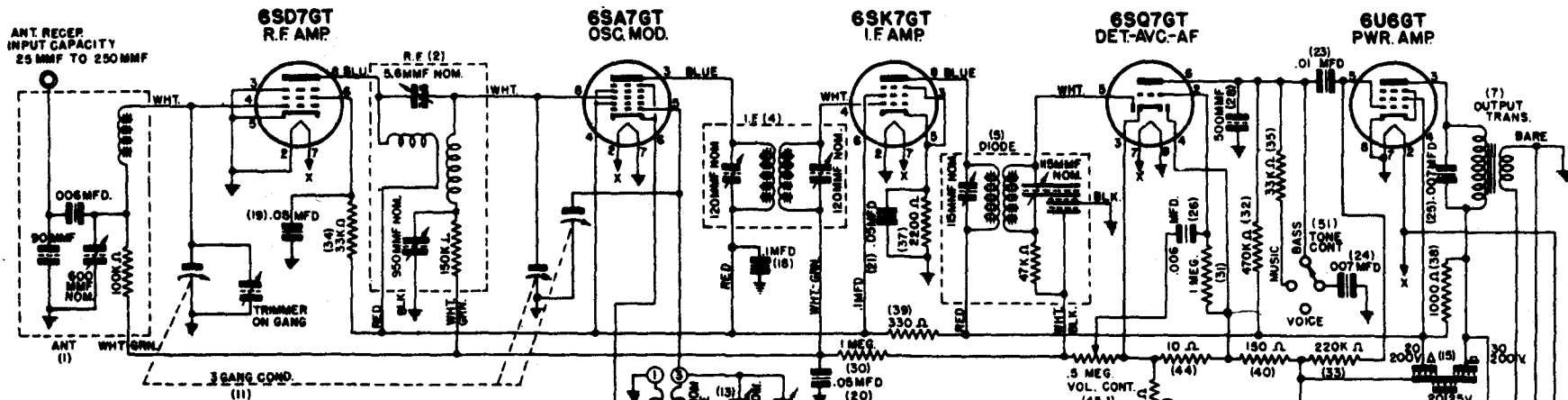

I.F. = 262 KC
FREQ. RANGE
545 KC TO 1600 KC

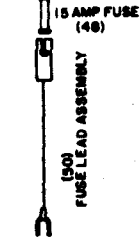
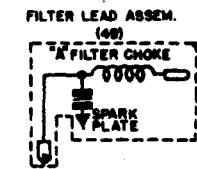

NOTE:
ALL VOLTAGES MEASURED ON A 1000 OHM PER VOLT VOLTMETER

VOLTAGE CHART			
TUBE	PLATE TO GND.	SCREEN TO GND.	CATH. TO GND.
6SD7GT R.F. AMP	118 V.	70 V.	0
6SA7GT OSC. MOD.	118 V.	118 V.	0
6SK7GT I.F. AMP.	120 V.	118 V.	7 V.
6SQ7GT DET. AVC. A.F.	38 V.	—	-8.0 V.
6UG6T PWR. AMP.	148 V.	120 V.	0
6X5GT RECT.	A.C.	—	148 V.

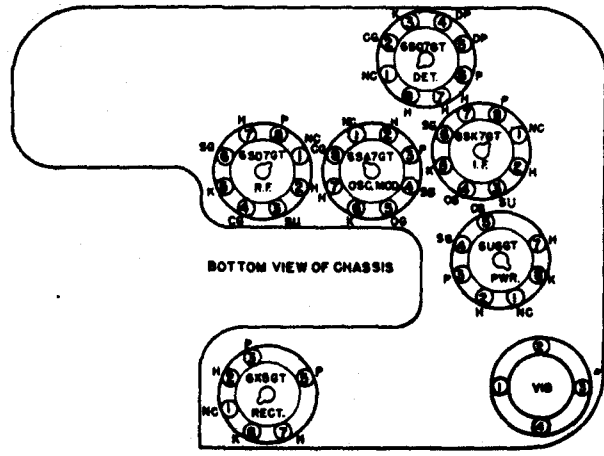
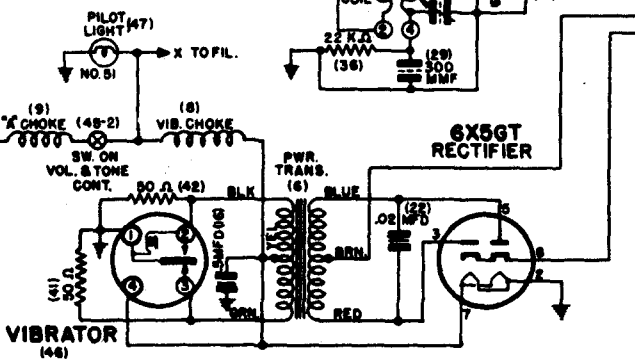

Motorola

Model 42-5

DIAG. NO.	PART NO.	DESCRIPTION	DIAG. NO.	PART NO.	DESCRIPTION
1	1A23107	ANTENNA COIL & SHIELD ASSEMBLY	27	21B6500	MOLDED MICA COND. (.500 MF.D.) 20%
2	1A23098	R.F. COIL & SHIELD ASSEMBLY	28	21B6500	MOLDED MICA COND. (.500 MF.D.) 20%
3	2A23058	OSCILLATOR COIL	29	21A23110	CERAMIC MICA COND. (.300 MF.D.) 5%
4	1A23096	I.F. COIL & SHIELD ASSEMBLY	30	6B61599	CARBON RESISTOR (1.0 MEG-1/3-20) INS.
5	1A23094	DIODE COIL & SHIELD ASSEMBLY	31	6B61599	CARBON RESISTOR (1.0 MEG-1/3-20) INS.
6	25B23103	POWER TRANSFORMER	32	6B61600	CARBON RESISTOR (.470, 000-1/3-20) INS.
7	25A23059	OUTPUT TRANSFORMER	33	6B62012	CARBON RESISTOR (.220, 000-1/3-20) INS.
8	2A17010	VIBRATOR CHOKER	34	6B62012	CARBON RESISTOR (.33, 000-1/2-20) INS.
9	2A23092	"A" CHOKER & BRACKET	35	6B63029	CARBON RESISTOR (.33, 000-1/3-20) INS.
10	50B2188L	SPEAKER (6-1/2" ELECTRO)	36	6B6212	CARBON RESISTOR (.22, 000-1/3-20) INS.
11	1A21659	TUNING UNIT, GANG & PULLEY ASSEMBLY	37	6B6210	CARBON RESISTOR (2200-1/3-20) INS.
12	20A23135	OSC. PADDER & BRKT. (9-99 MF.D.)	38	6B6184	CARBON RESISTOR (1000-1-20) N.I.
13	20A17237	TRIMMER & BRACKET (5 MF.D.- NOM.)	39	6B62010	CARBON RESISTOR (.330-1/2-20) INS.
14	20A23807	COMPENSATING CONDENSER	40	6B6330	CARBON RESISTOR (150-1-10) INS.
15	23A22738	ELECT. COND. (.30-20/200V.-20/25V.)	41	6B6005	CARBON RESISTOR (50-1/2-20) N.I.
16	8A19133	TUBULAR CONDENSER (.5-100V.)	42	6B6005	CARBON RESISTOR (50-1/2-20) N.I.
17	8A11095	TUBULAR CONDENSER (.1-100V.)	43	6B6331	CARBON RESISTOR (27-1/3-10) INS.
18	8A3310	TUBULAR CONDENSER (.1-200V.)	44	6B6332	CARBON RESISTOR (10-1/3-10) INS.
19	8A23146	TUBULAR CONDENSER (.05-200V.)	45	18A21657	VOL. CONTROL & SWITCH (.5 MEG.)
20	8A13514	TUBULAR CONDENSER (.05-100V.)	46	18A5067	VIBRATOR
21	8A13514	TUBULAR CONDENSER (.05-100V.)	47	65A151	BULB (WHITE BEAD) #51
22	8A22760	TUBULAR CONDENSER (.02-600V.)	48	65A165	FUSE (15 AMP.) 3A0
23	8A23053	TUBULAR CONDENSER (.01-200V.)	49	1A21715	FILTER LEAD ASSEMBLY
24	8A2289	TUBULAR CONDENSER (.007-600V.)	50	1A1817L	FUSE LEAD ASSEMBLY
25	8A2289	TUBULAR CONDENSER (.007-600V.)	51	10A21606	MIDGET TONE SWITCH (3 POINT)
26	8A1529	TUBULAR CONDENSER (.006-100V.)			

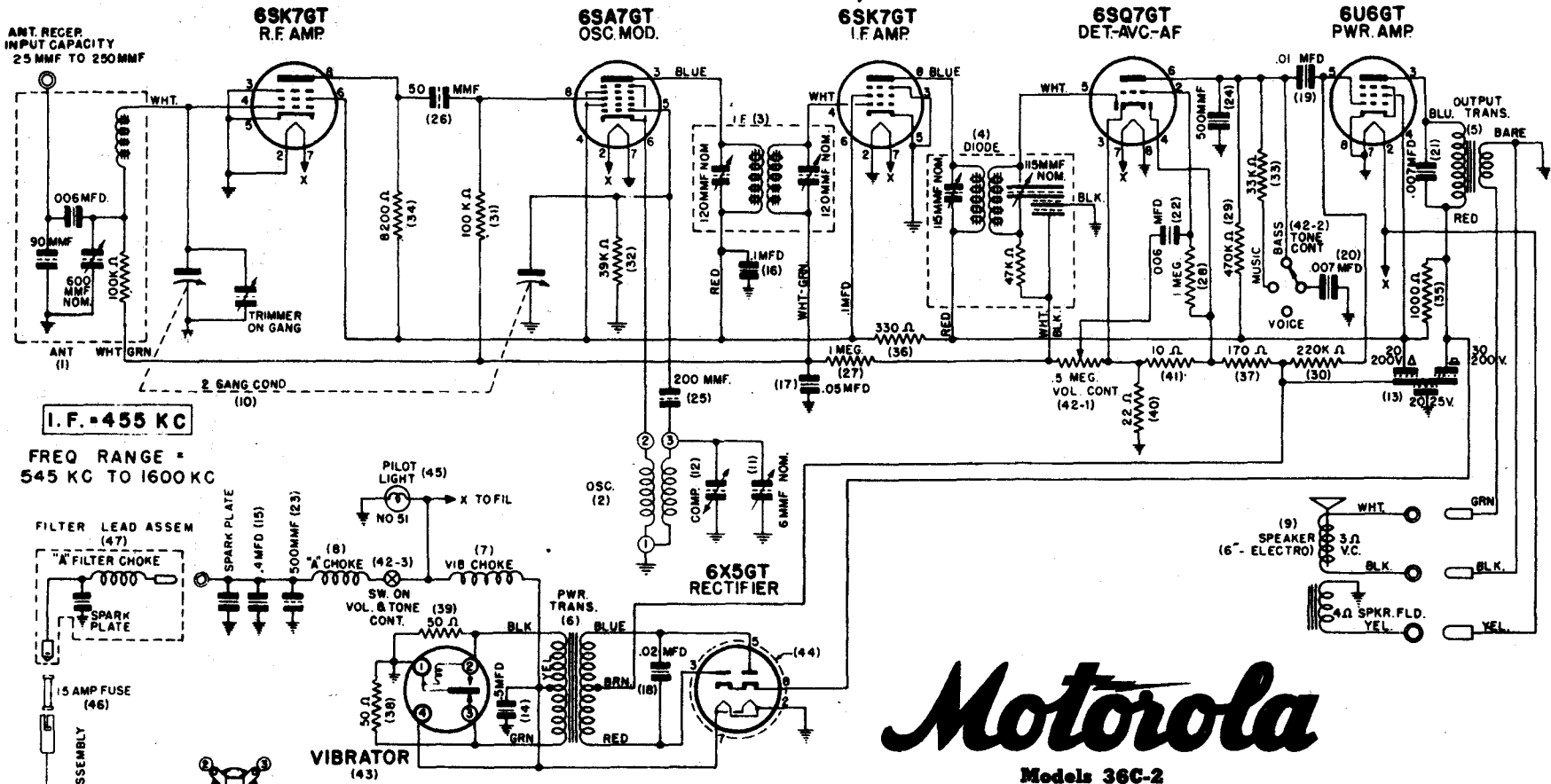

I. F. = 455 KC
FREQ RANGE = 545 KC TO 1600 KC

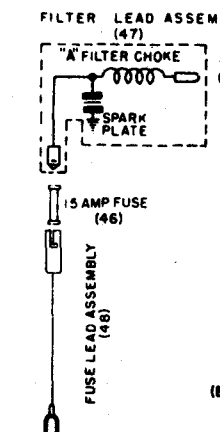

A INPUT CURRENT DRAIN: 6.25 AMP. AT 6.3 V.
MAX. PWR. OUTPUT: .4 WATTS.
NOTE: ALL VOLTAGES MEASURED ON A 1000 OHM PER VOLT VOLTMETER

VOLTAGE CHART			
TUBE	PLATE TO GND.	SCREEN TO GND.	CATH. TO GND.
6SK7GT R.F. AMP	115 V.	V.	0
6SA7GT OSC. MOD.	115 V.	115 V.	0
6SK7GT I.F. AMP	120 V.	115 V.	0
6SQ7GT DET. AVC. A.F.	35 V.	—	-2.5 V.
6U6GT P.W. AMP	145 V.	120 V.	0
6X5GT RECT.	A.C.	—	145 V.

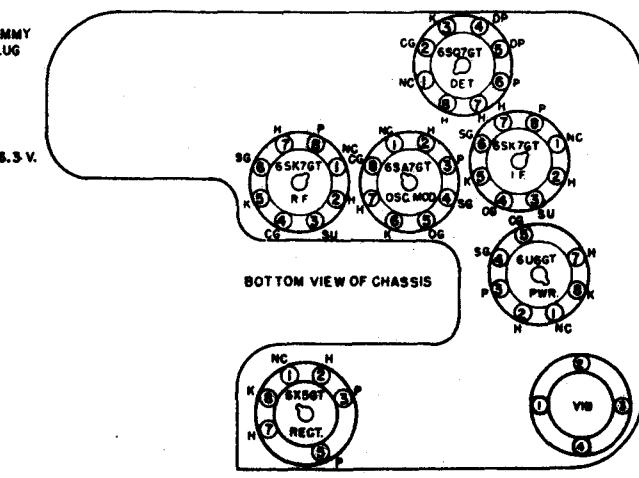

Motorola

Models 36C-2

MODEL 36C2 SCHEMATIC DIAGRAM PARTS LIST

DIAG. NO.	PART NO.	DESCRIPTION	DIAG. NO.	PART NO.	DESCRIPTION
1	1N2L323	ANTENNA COIL & SHIELD ASSEMBLY	25	21B6501	MOLDED MICA COND. (200 MMFD) 20%
2	2L2K375R	OSCILLATOR COIL	26	21A128L3	CERAMIC COND. (50 MMFD)
3	1N2L327	I.F. COIL & SHIELD ASSEMBLY	27	686159	CARBON RESISTOR (1 MEG-1/3-20) INS.
4	1N2L327	DIODE COIL & SHIELD ASSEMBLY	28	686159	CARBON RESISTOR (1 MEG-1/3-20) INS.
5	25A2L525	OUTPUT TRANSFORMER	29	686160	CARBON RESISTOR (170,000-1/3-20) INS.
6	25B23103	POWER TRANSFORMER	30	68620L	CARBON RESISTOR (220,000-1/3-20) INS.
7	2A117010	VIBRATOR CHOKE	31	686165	CARBON RESISTOR (100,000-1/3-20) INS.
8	2LA23092	"A" CHOK & BRACKET	32	686355	CARBON RESISTOR (39,000-1/3-20) INS.
9	5082L561	SPEAKER (6" ELECTRO)	33	686329	CARBON RESISTOR (33,000-1/3-20) INS.
10	1N2L543	TUNING UNIT, GANG & PULLEY ASSEMBLY (2 GANG)	34	686362	CARBON RESISTOR (8,200-1/3-20) INS.
11	20A17237	TRIMMER & BRACKET (.6 MMFD NOM.)	35	68618L	CARBON RESISTOR (1,000-1/20) N.I.
12	20A20350	COMPENSATING CONDENSER	36	686010	CARBON RESISTOR (330-1/2-20) INS.
13	23A22730	ELECTROLYTIC CONDENSER (20-30/200V, 20/25V)	37	686363	CARBON RESISTOR (170-1-10) INS.
14	8A12133	TUBULAR CONDENSER (.5-100V)	38	686005	CARBON RESISTOR (50-1/2-20) N.I.
15	8A11095	TUBULAR CONDENSER (.5-100V)	39	686005	CARBON RESISTOR (50-1/2-20) N.I.
16	8A3310	TUBULAR CONDENSER (.1-200V)	40	686356	CARBON RESISTOR (22-1/3-10) INS.
17	8A13514	TUBULAR CONDENSER (.05-100V)	41	686332	CARBON RESISTOR (10-1/3-10) INS.
18	8A22760	TUBULAR CONDENSER (.02-600V)	42	1882L046	VOL. TONE CONTROL & SWITCH (.5 MEG)
19	8A23053	TUBULAR CONDENSER (.01-200V)	43	10A3507	VIBRATOR
20	8A22891	TUBULAR CONDENSER (.007-600V)	44	20A25283	TUBE SHIELD
21	8A22891	TUBULAR CONDENSER (.007-600V)	45	65K1151	BULB, (WHITE READ) #51
22	8A15259	TUBULAR CONDENSER (.006-100V)	46	65K1165	FILTER (15 AMP) 3AG
23	21B6500	MOLDED MICA COND. (500 MMFD) 20%	47	1N2L555	FILTER LEAD ASSEMBLY
24	21B6500	MOLDED MICA COND. (500 MMFD) 20%	48	1N2L308	FILTER LEAD ASSEMBLY

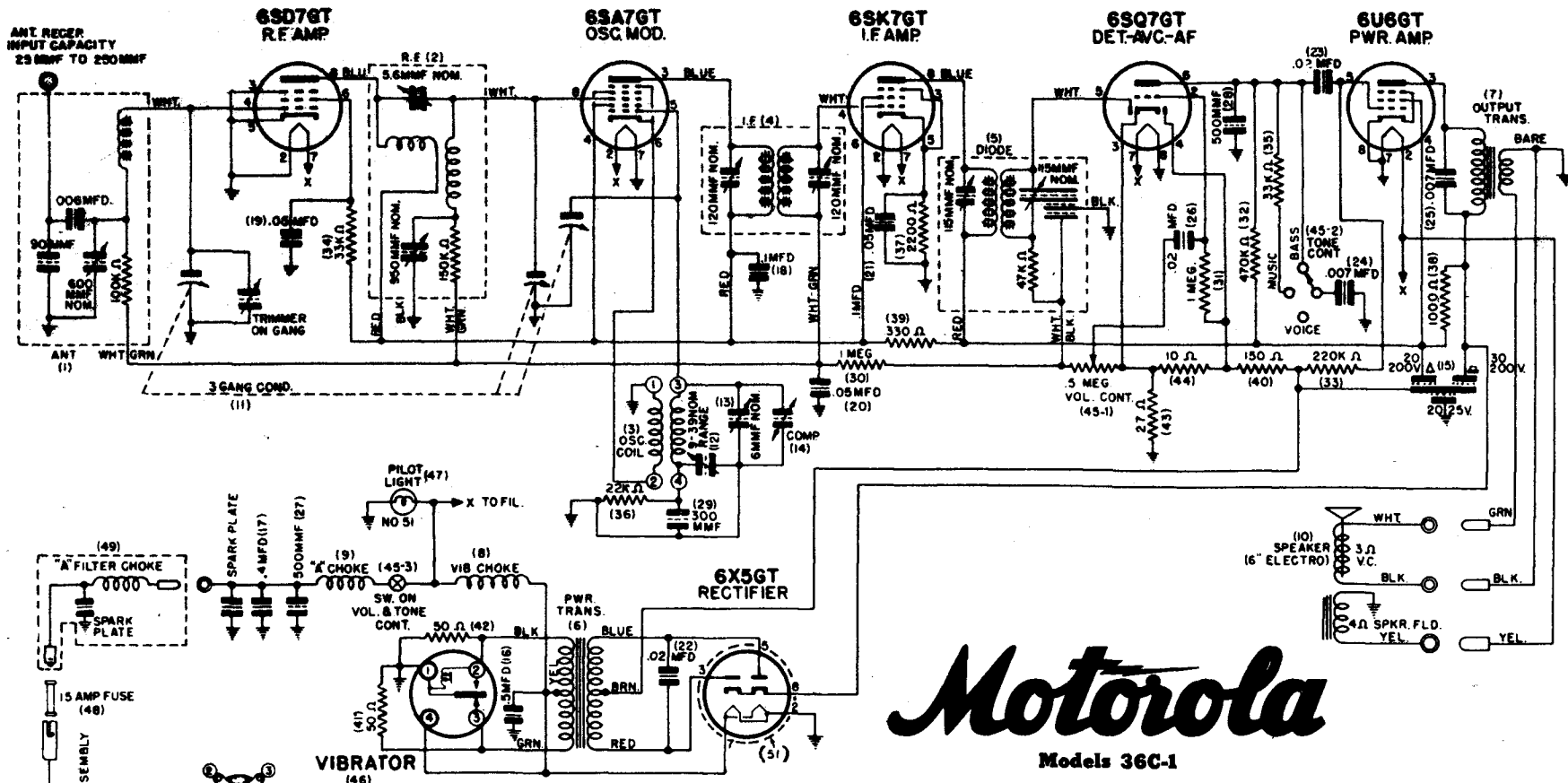

Motorola

Models 36C-1

MODEL 36-C1 SCHEMATIC DIAGRAM PARTS LIST

DIAG. NO.	PART NO.	DESCRIPTION	DIAG. NO.	PART NO.	DESCRIPTION
1	1123107	ANTENNA COIL & SHIELD ASSEMBLY	27	2186500	MOLDED MICA COND. (500 MFD) 20%
2	1123098	R.F. COIL & SHIELD ASSEMBLY	28	2186500	MOLDED MICA COND. (500 MFD) 20%
3	26A21015	OSC. COIL & MFG. STRIP	29	21A23110	CERAMIC MICA COND. (300 MFD) 5%
4	1123096	I.F. & SHIELD ASSEMBLY	30	66459	CARBON RESISTOR (1 MEG.-1/3-20) 1/2 W.
5	1123098	DIODE COIL & SHIELD ASSEMBLY	31	66459	CARBON RESISTOR (1 MEG.-1/3-20) 1/2 W.
6	25625105	POWER TRANSFORMER	32	66460	CARBON RESISTOR (170,000-1/3-20) 1/2 W.
7	25A23059	OUTPUT TRANSFORMER	33	66460	CARBON RESISTOR (220,000-1/3-20) 1/2 W.
8	26A1010	VIBRATOR CHOKE	34	66462	CARBON RESISTOR (33,000-1/3-20) 1/2 W.
9	26A23092	"A" CHOKE & BRACKET	35	66462	CARBON RESISTOR (33,000-1/3-20) 1/2 W.
10	5062158	SPEAKER (6" ELECTRO)	36	66462	CARBON RESISTOR (22,000-1/3-20) 1/2 W.
11	1123101	TUNING UNIT, JANG & RULLY ASSY.	37	66463	CARBON RESISTOR (2,200-1/3-10) 1/2 W.
12	20A23135	OSCILLATOR PACTER & BRACKET (9-30 MFD.)	38	66510	CARBON RESISTOR (330-1/2-20) 1/2 W.
13	20A17237	TRIMMER & BRACKET (6 MFD. NOM.)	39	66510	CARBON RESISTOR (150-1/10) 1/2 W.
14	20A23287	COMPENSATING CONDENSER	40	66530	CARBON RESISTOR (150-1/10) 1/2 W.
15	23A22738	ELECTROLYTIC COND. (30-20/200V.-20/25V.)	41	66505	CARBON RESISTOR (50-1/2-20) 1/2 W.
16	8A19133	TUBULAR CONDENSER (.5-100V.)	42	66505	CARBON RESISTOR (50-1/2-20) 1/2 W.
17	8A11095	TUBULAR CONDENSER (.1-100V.)	43	66531	CARBON RESISTOR (27-1/3-10) 1/2 W.
18	8A3310	TUBULAR CONDENSER (.1-300V.)	44	66532	CARBON RESISTOR (10-1/3-10) 1/2 W.
19	8A23116	TUBULAR CONDENSER (.05-100V.)	45	19821016	VOL. TONE CONTROL & SWITCH (.5MEG)
20	8A13514	TUBULAR CONDENSER (.05-100V.)	46	48A5087	VIBRATOR
21	8A13514	TUBULAR CONDENSER (.05-100V.)	47	65A1151	BLAD (WHITE DEAD) 51
22	8A22760	TUBULAR CONDENSER (.02-200V.)	48	65A1165	FUSE (15 AMP.) 3AG
23	8A21053	TUBULAR CONDENSER (.02-200V.)	49	1123108	FILTER LEAD ASSEMBLY
24	8A2289	TUBULAR CONDENSER (.007-600V.)	50	1123108	FUSE LEAD ASSEMBLY
25	8A2289	TUBULAR CONDENSER (.007-600V.)	51	26A11760	BANTAM TUBE SHIELD
26	8A1697	TUBULAR CONDENSER (.02-100V.)			

NOTE
ALL VOLTAGES MEASURED ON A 1000 OHM PER VOLT VOLTMETER

TUBE	PLATE TO GND	SCREEN TO GND	CATH. TO GND
6S07GT	115V.	70V.	0
6SA7GT	115V.	115V.	0
6SK7GT	120V.	115V.	7V.
6SQ7GT	35V.	—	-2.8V.
6U6GT	140V.	120V.	0
6X5GT	A.C.	—	145V.

CURRENT INPUT:- 7 AMP. AT 6.3 V.
MAX. P.W.R. OUTPUT:- 4.0 WATTS

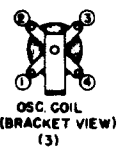
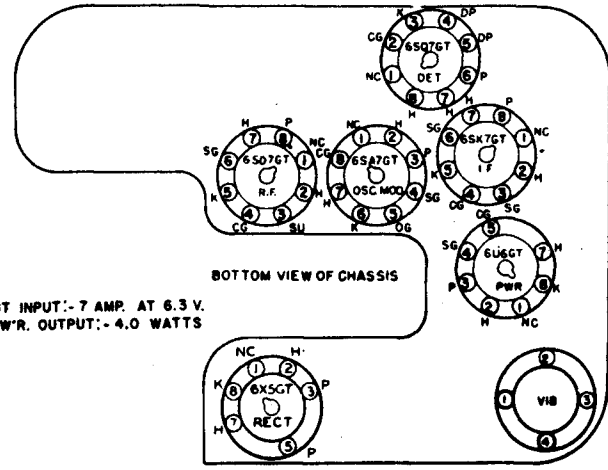

OSC. COIL (BRACKET VIEW) (3)

A' INPUT

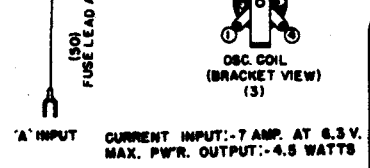
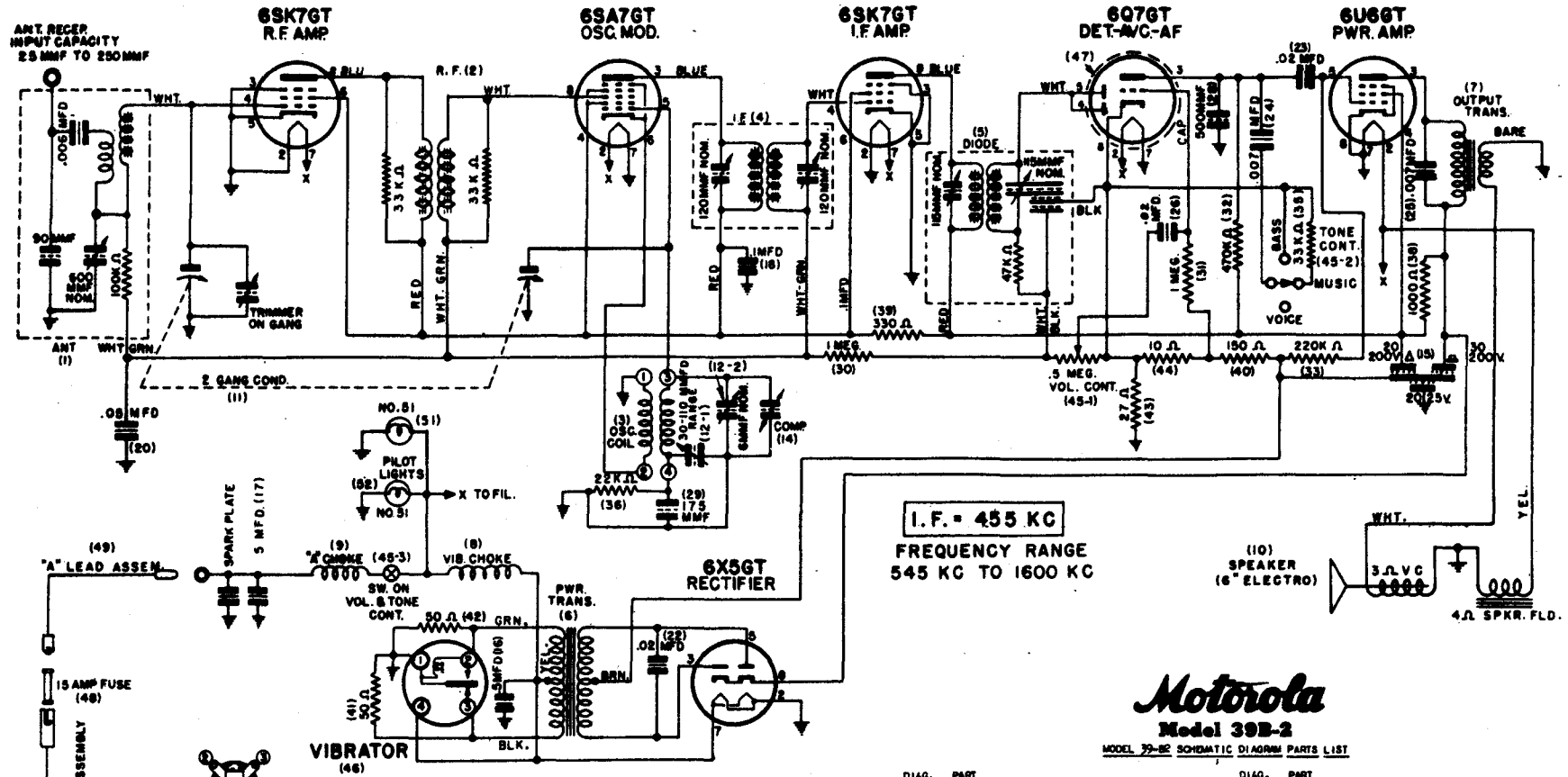

A' INPUT CURRENT INPUT: .7 AMP. AT 6.3 V.
MAX. PWR. OUTPUT: 4.5 WATTS

NOTE: ALL VOLTAGES MEASURED ON A 1000 OHM PER VOLT VOLTMETER

VOLTAGE CHART			
TUBE	PLATE TO GND.	SCREEN TO GND.	GRID TO GND.
6SK7GT R.F. AMP	105 V.	105 V.	0
6SA7GT OSC. MOD.	105 V.	105 V.	0
6SK7GT I.F. AMP	115 V.	105 V.	0
6Q7GT DET. A.V.C. AF	30 V.	—	-2 V.
6U6GT PWR. AMP	145 V.	115 V.	0
6X5GT RECT.	A.C.	—	180 V.

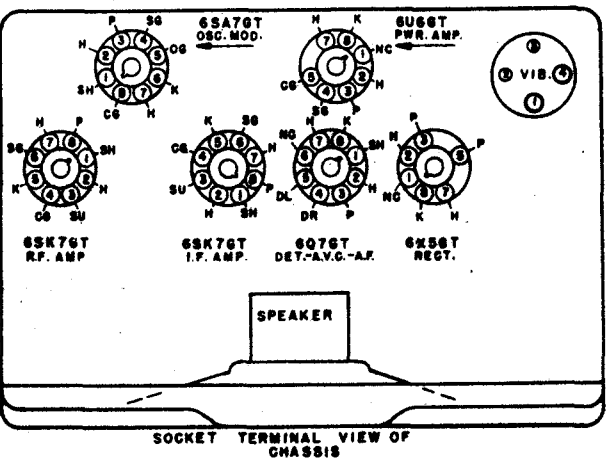

Motorola
Model 39B-2
MODEL 39-B2 SCHEMATIC DIAGRAM PARTS LIST

DIAG. NO.	PART NO.	DESCRIPTION	DIAG. NO.	PART NO.	DESCRIPTION
1	1126720	ANTENNA COIL & SHIELD ASSEMBLY	28	2126500	MOLDED MICA COND. (.500 MF) 20%
2	1126717	S.B. COIL & LEADS ASSEMBLY	29	21A1711/7	CERAMIC MICA COND. (.175 MF) 5%
3	1126715	OSC. COIL & LEADS ASSEMBLY	30	466139	CARBON RESISTOR (1.0 MED.-1/3-20) INS.
4	1126718	I.F. COIL & SHIELD ASSEMBLY	31	466139	CARBON RESISTOR (1.0 MED.-1/3-20) INS.
5	1126713	DIODE COIL & SHIELD ASSEMBLY	32	466160	CARBON RESISTOR (170,000-1/3-20) INS.
6	25282708	POWER TRANSFORMER	33	466201	CARBON RESISTOR (220,000-1/3-20) INS.
7	25282907	OUTPUT TRANSFORMER	35	466329	CARBON RESISTOR (33,000-1/3-20) INS.
8	21A1732	VIBRATOR CHOK	36	466212	CARBON RESISTOR (22,000-1/3-20) INS.
10	50282910	SPEAKER (6" ELECTRO)	38	466181	CARBON RESISTOR (1000-1-20) N.I.
11	1126736	GRID & FULLY ASSEMBLY	39	466010	CARBON RESISTOR (330-1/8-20) INS.
12	20A17153	DOUBLE TRIMMER & SWRT. (Trimmer - 6 MF. NOM.) (Passer-Range: 30-110 MF)	40	466330	CARBON RESISTOR (150-1-10) INS.
14	20	COMPENSATING CONDENSER	41	466005	CARBON RESISTOR (50-1/2-20) N.I.
15	23A2738	ELECT. COND. (30-20/200V.-20/25V.)	42	466005	CARBON RESISTOR (50-1/2-20) N.I.
16	8A19133	TUBULAR CONDENSER (.5-100V.)	43	466331	CARBON RESISTOR (27-1/3-10) INS.
17	8A17088	TUBULAR CONDENSER (.5-100V.)	44	466332	CARBON RESISTOR (10-1/3-10) INS.
18	8A3310	TUBULAR CONDENSER (.1-200V.)	45	1126309	VOL., TONE CONT. & SWITCH (.5 MEG.)
20	8A13514	TUBULAR CONDENSER (.05-100V.)	46	14A5067	VIBRATOR
22	8A22760	TUBULAR CONDENSER (.02-600V.)	47	85X1760	BAYNETA TUBE SHIELD
23	8A21053	TUBULAR CONDENSER (.02-200V.)	48	65X1165	FUSE (15 AMP.) 3AG
24	8A2289	TUBULAR CONDENSER (.007-600V.)	49	14A595	A' LEAD ASSEMBLY
25	8A2289	TUBULAR CONDENSER (.007-600V.)	50	1126554	FUSE LEAD ASSEMBLY
26	8A1697	TUBULAR CONDENSER (.02-100V.)	51	65X1151	BULB (WHITE BEAD) #51
			52	65X1151	BULB (WHITE BEAD) #51

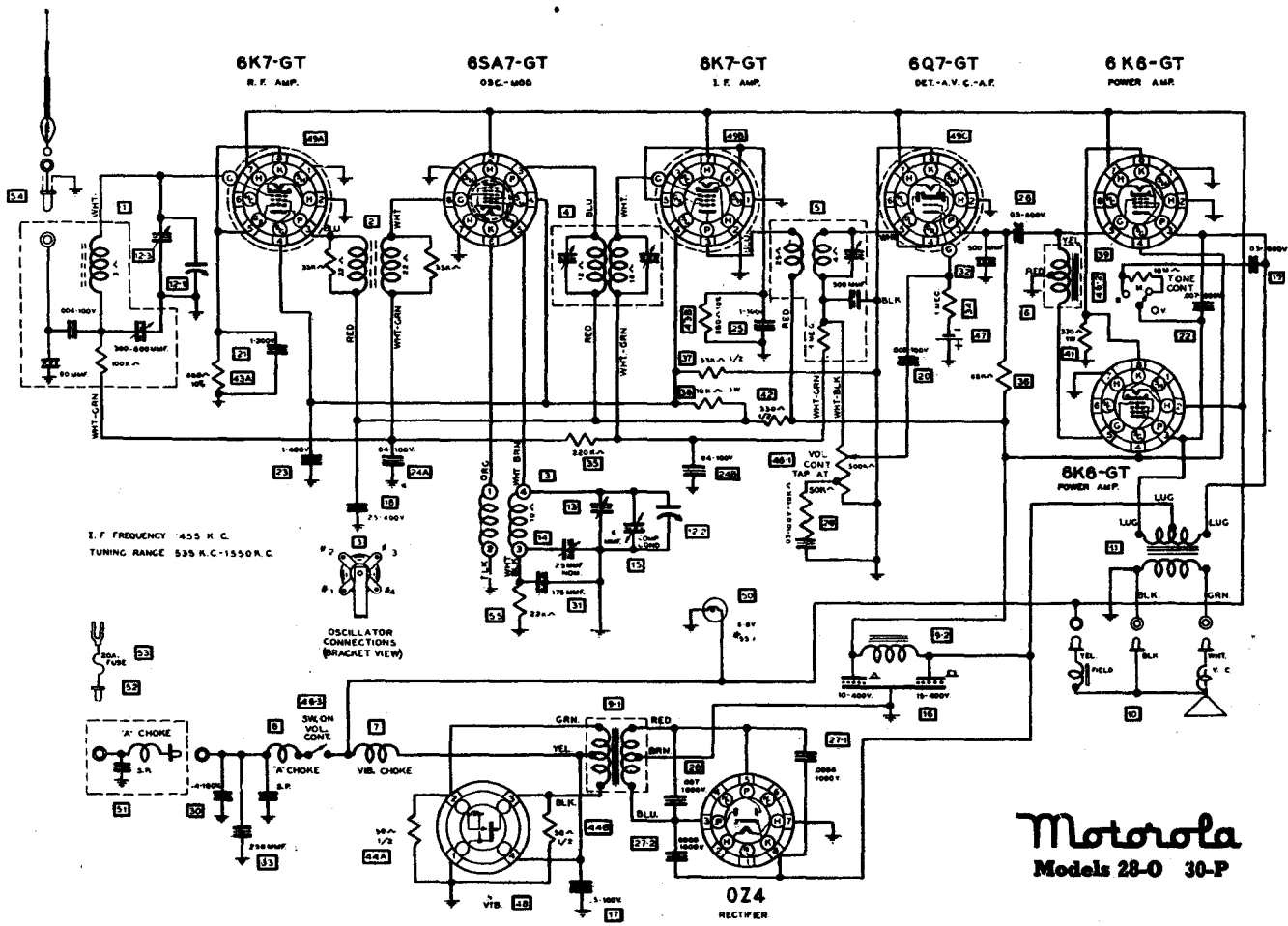
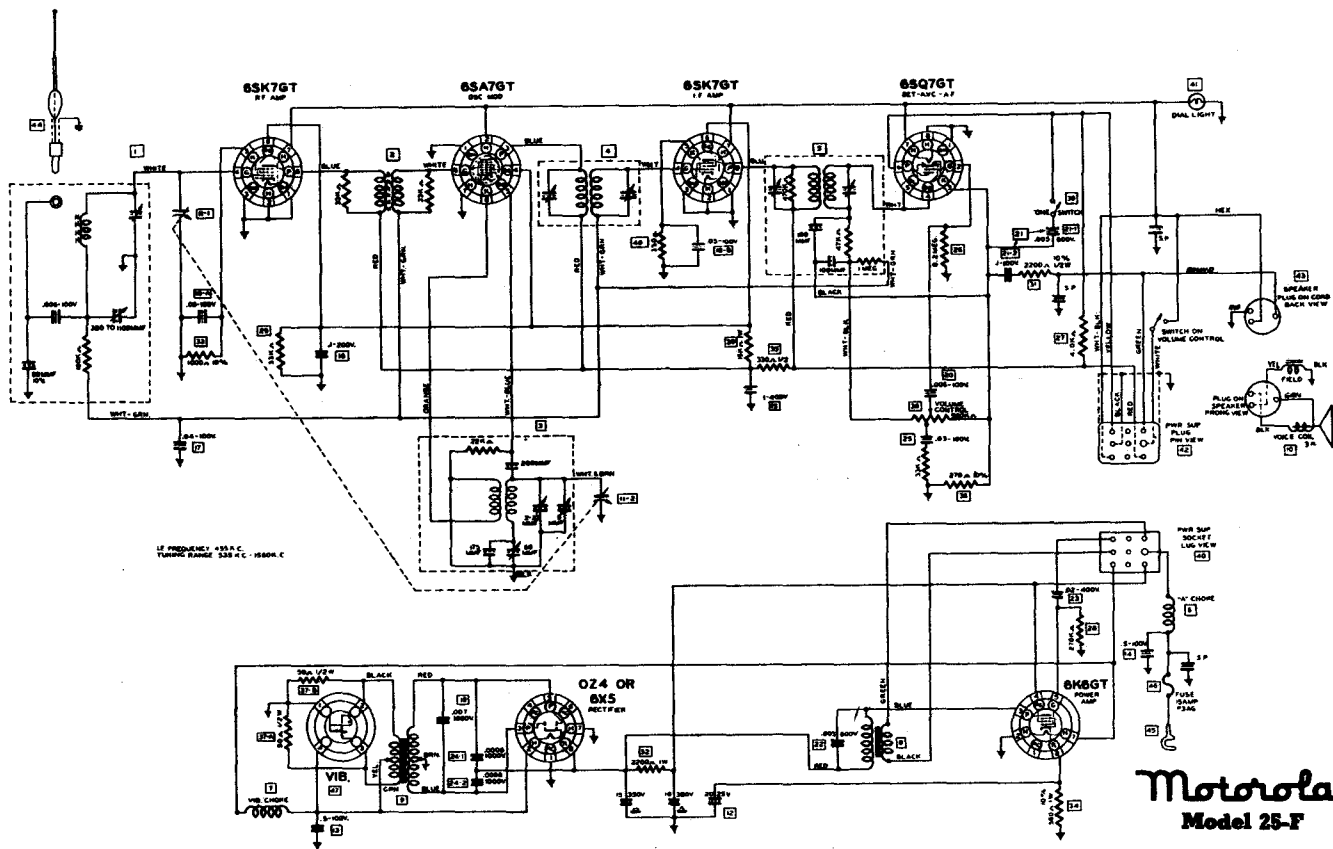

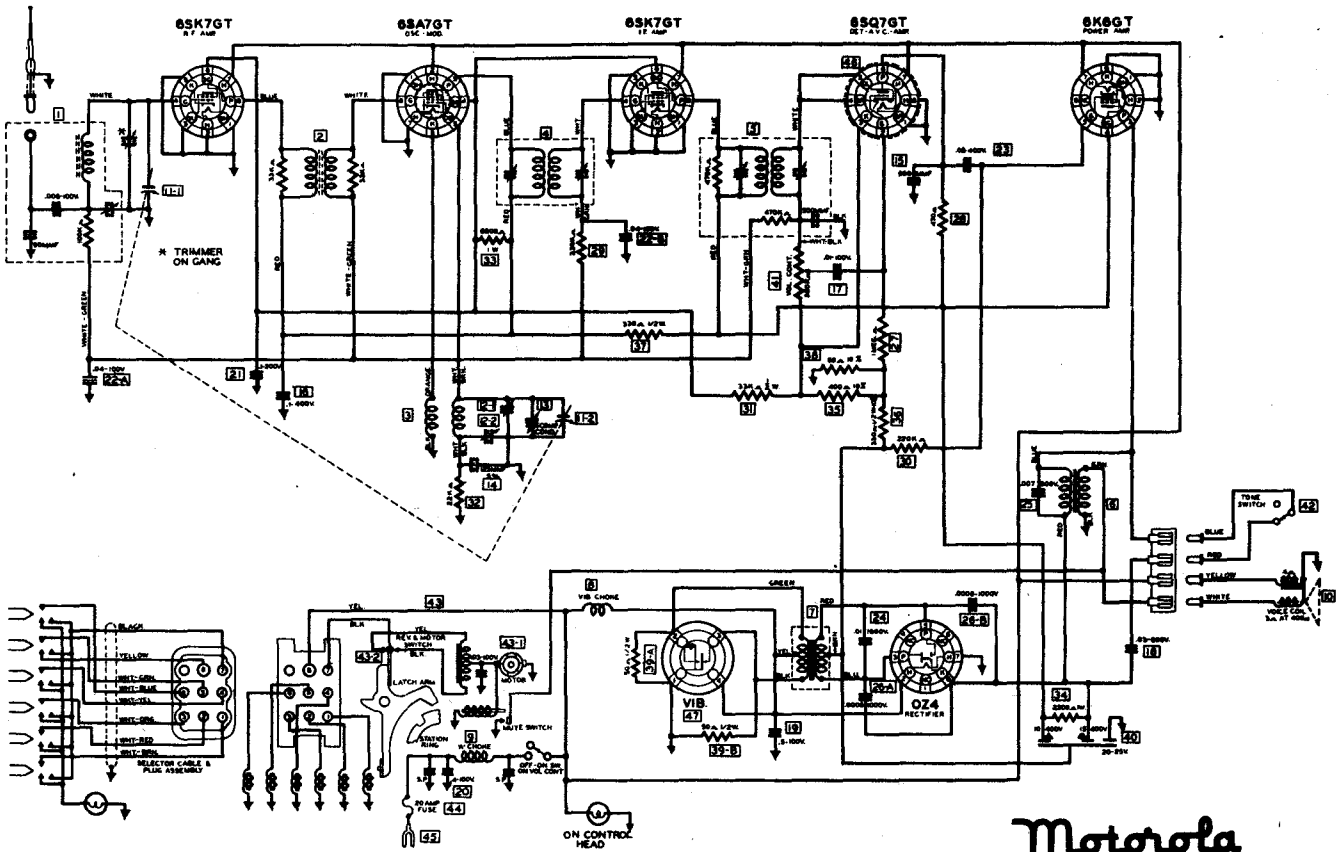

Motorola
Model 34-K-6

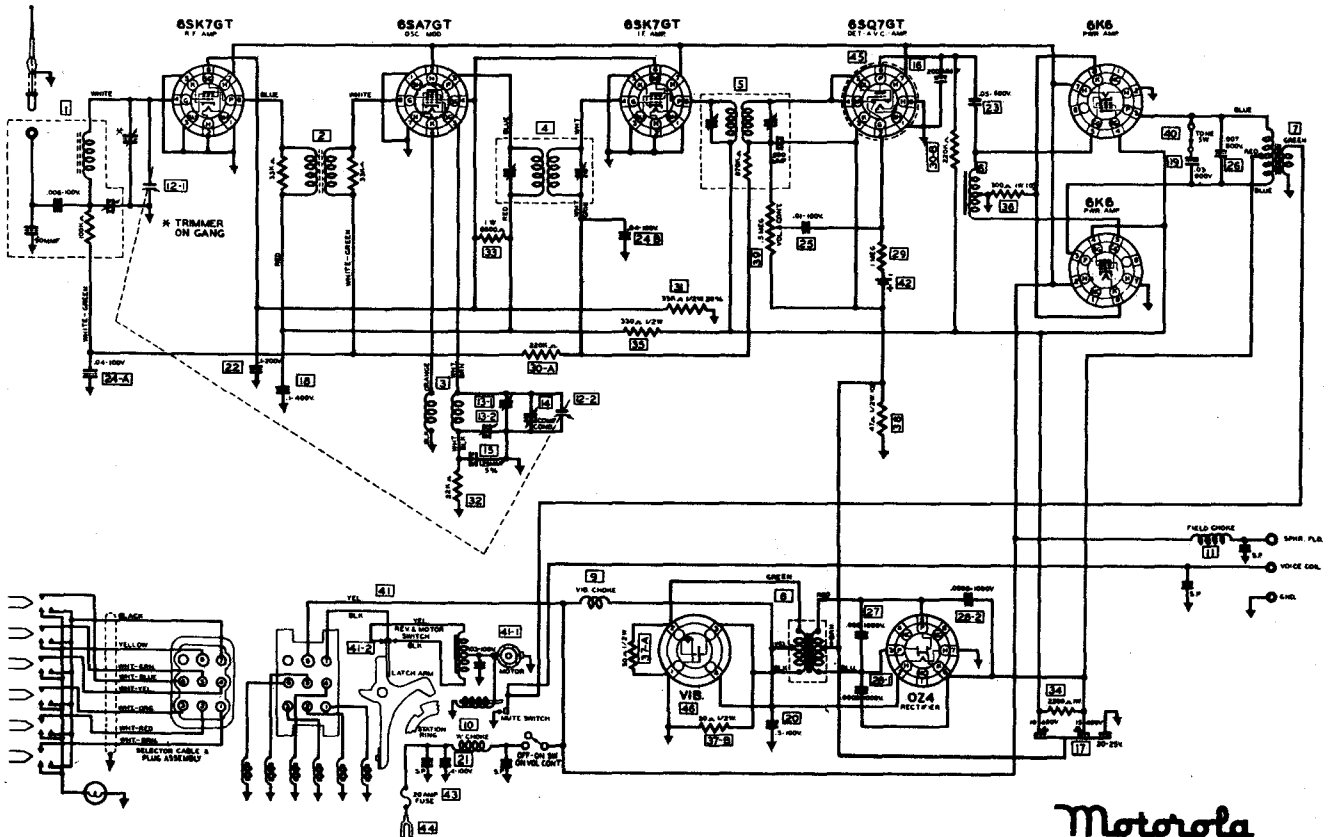

Motorola
Model 34-W-7

I.F. = 455 KC.

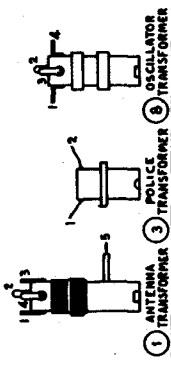
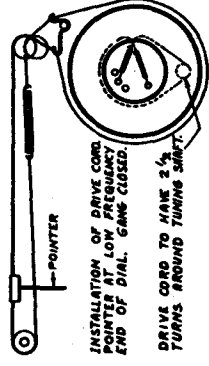
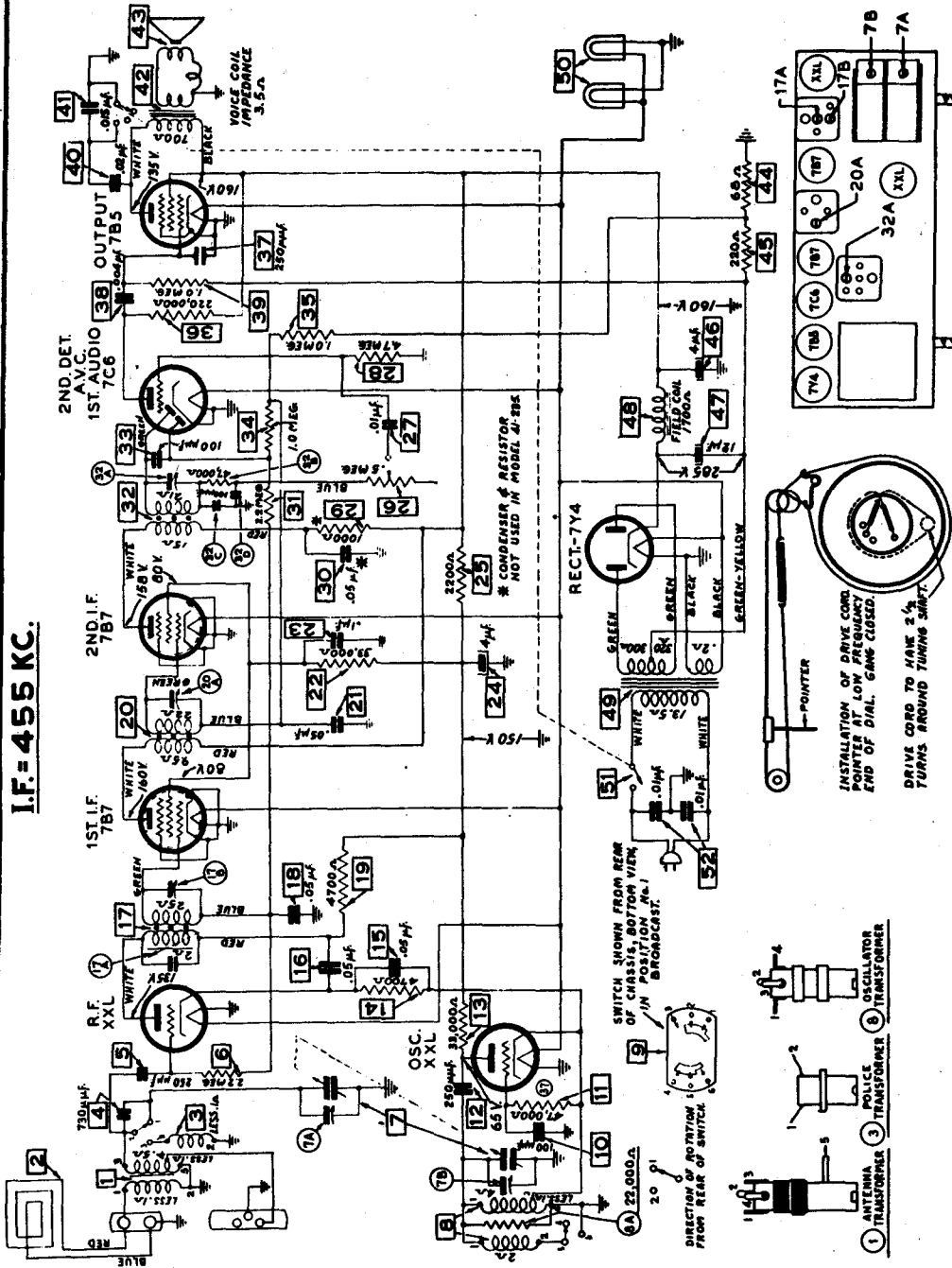

PHILCO Philadelphia, Pa.

Models 41-230; 41-235, Code 121

Operations in Order	SIGNAL GENERATOR		RECEIVER		
	Output Connections to Receiver	Dial Setting	Dial Setting	Control Setting	Adjust Compensators in Order
1	Ant. Section of Tuning Cond.	455 K. C.	540 K. C. Tuning Cond. Closed	Vol. Max. Range Switch "Brdcat"	32A, 20A 17B, 17A
2	Loop—See above Instructions	1600 K. C.	1600 K. C.	Vol. Max. Range Switch "Brdcat"	7B
3	Loop—See above Instructions	1500 K. C.	1500 K. C.	Vol. Max. Range Switch "Brdcat"	7A

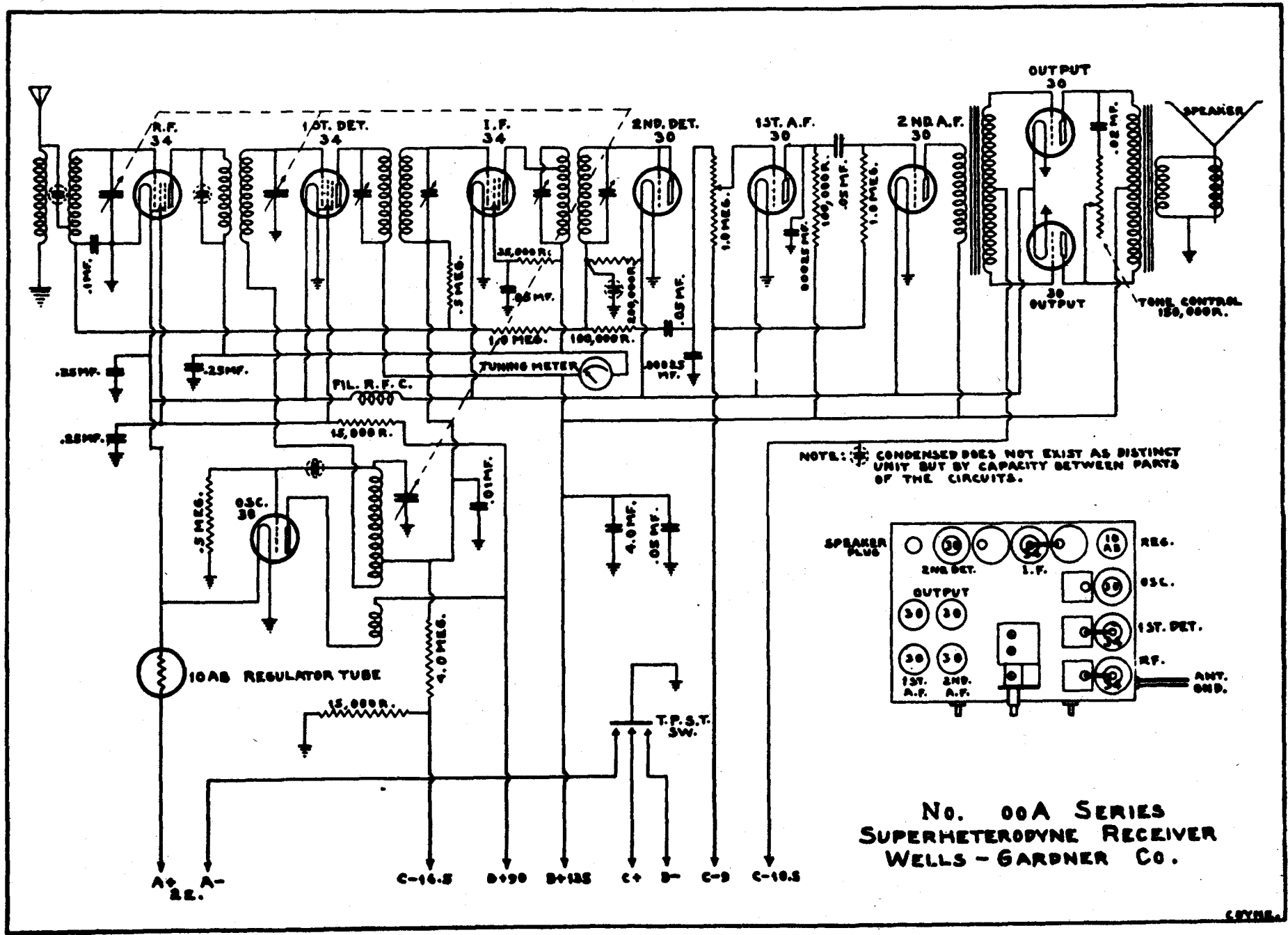

Westinghouse Radio

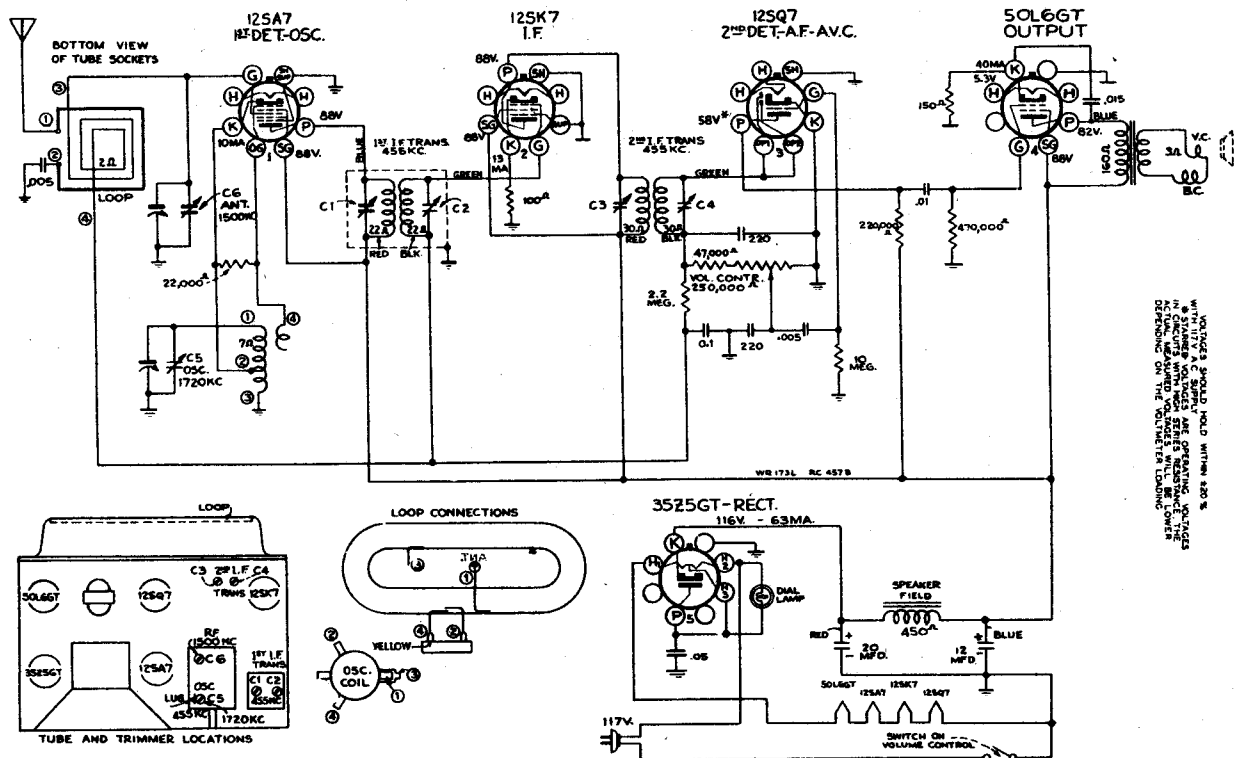

Schematic Circuit Diagram Model WR-173L

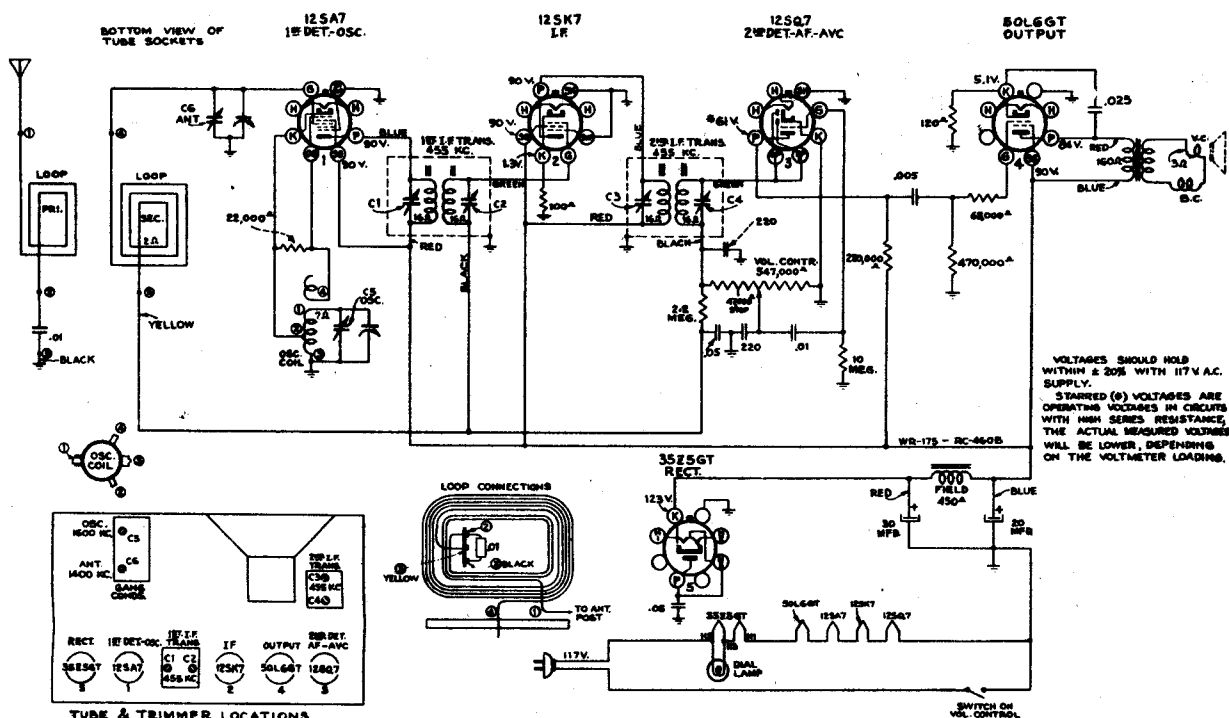

Schematic Circuit Diagram Model WR-175

Westinghouse Radio Model WR-388

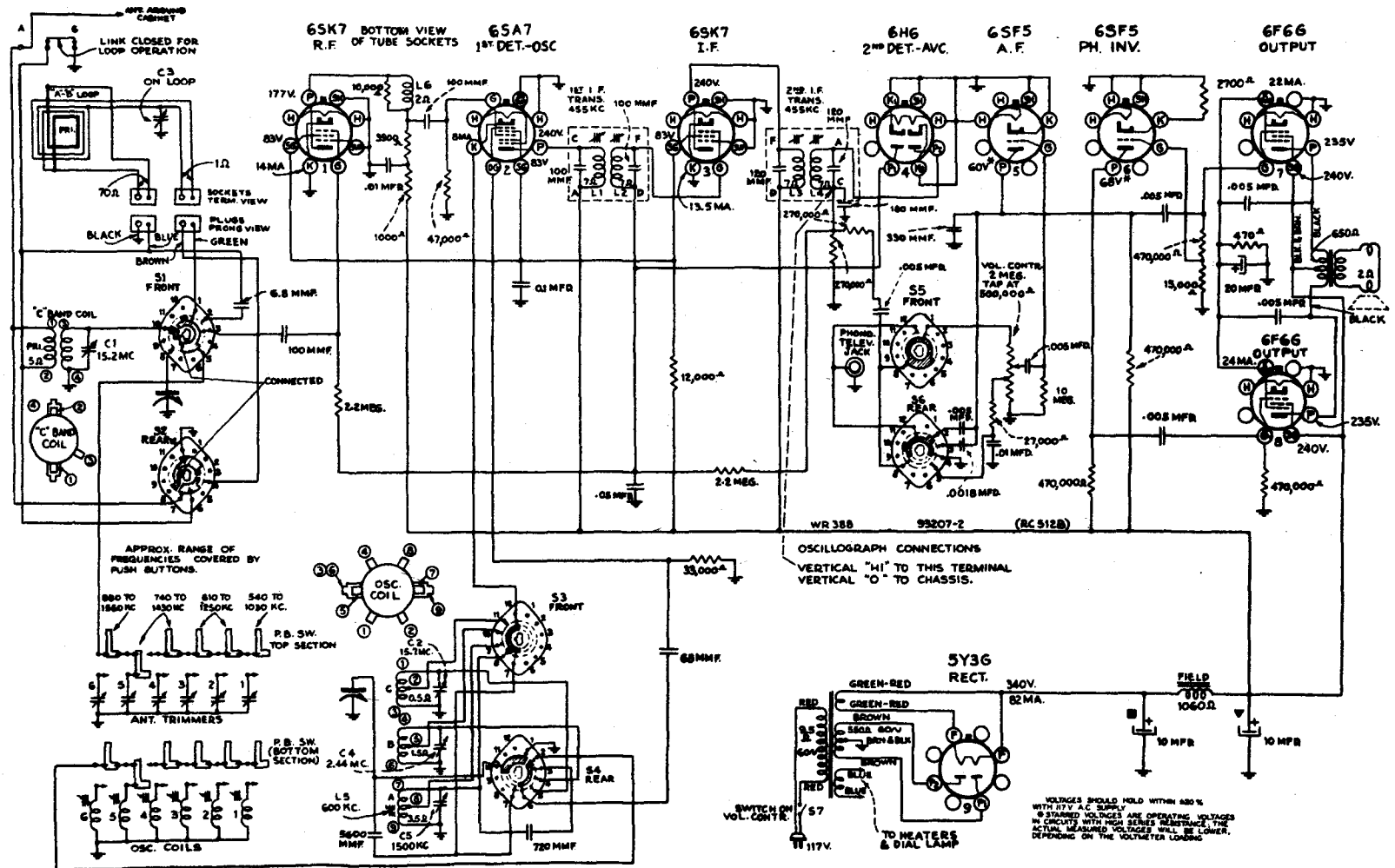

Westinghouse Radio Model WR-470

Five-Tube, Single-Band, A-C, Superheterodyne Radio-Phonograph

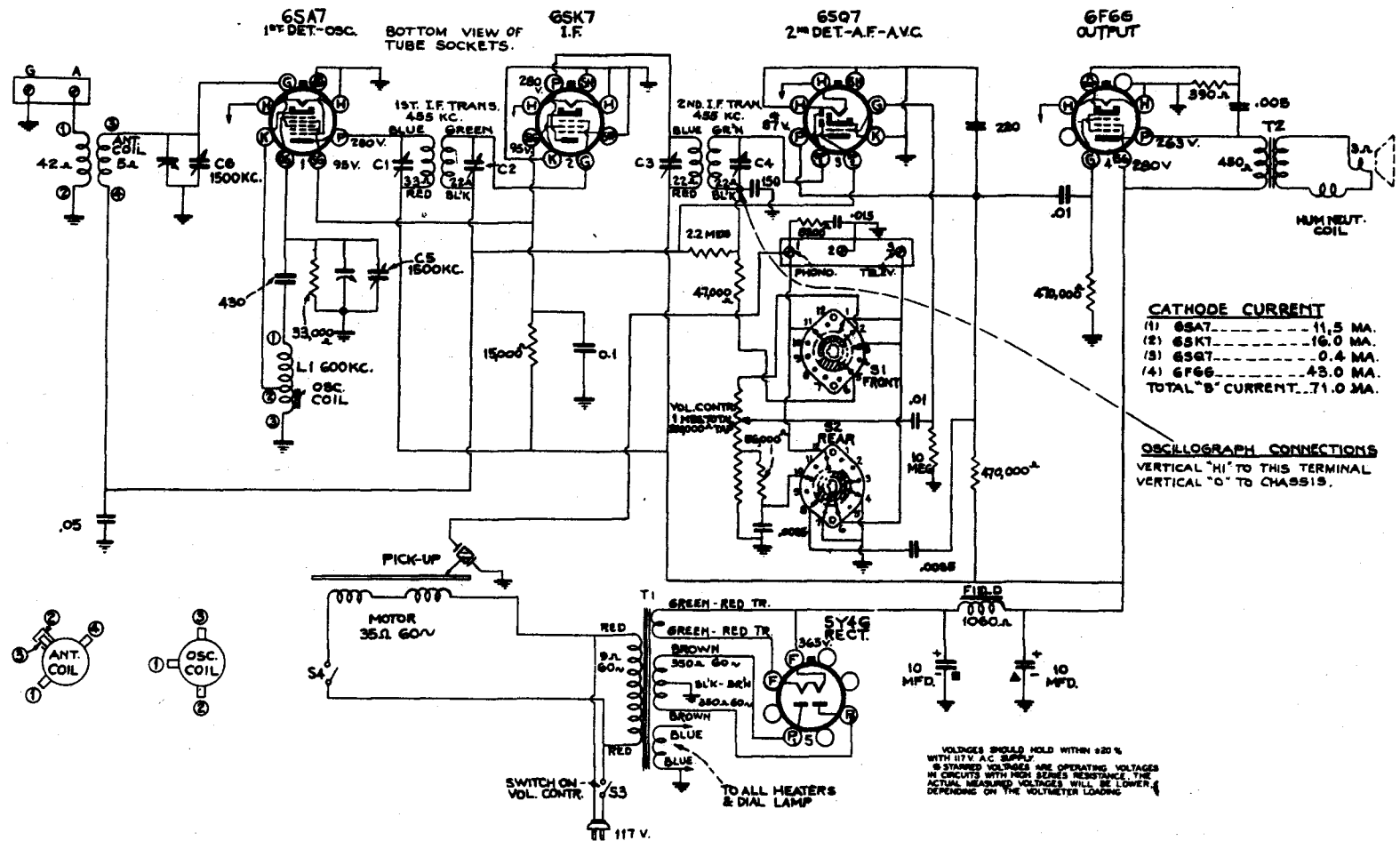

ZENITH RADIO CORPORATION

CHICAGO • ILLINOIS

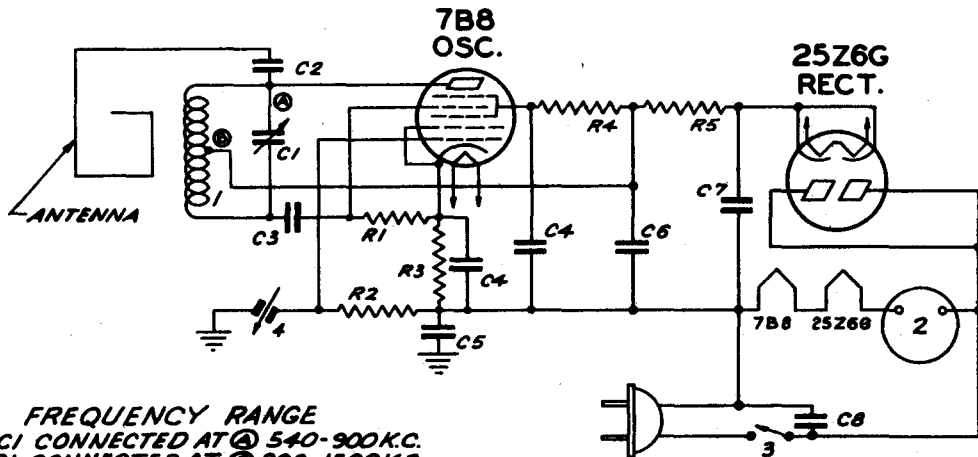

FREQUENCY RANGE
 C1 CONNECTED AT ① 540-900K.C.
 C1 CONNECTED AT ② 900-1500K.C.

MODELS
 S8500Z

DIAG. N ^o	PART N ^o	DESCRIPTION	DIAG. N ^o	PART N ^o	DESCRIPTION
C1	22-690	TUNING CONDENSER	R2	63-464	1 MEG OHM 1/4 W.
C2	22-127	25 MMFD.	R3	63-581	470 OHM 1/4 W.
C3	22-182	.00025 MFD.	R4	63-964	4700 OHM 1/2 W.
C4	22-829	.05 MFD.	R5	63-707	4700 OHM 1/4 W.
C5	22-827	.1 MFD.			
C6	22-1061	8 MFD. ELECTROLYTIC	1	58611	OSC. COIL ASSEM.
C7	22-1061	16 MFD. "	2	141-85	MOTOR (60~)
C8	22-869	.05 MFD.	3	85-191	A.C. SWITCH
			4	MZ-30	PICKUP
R1	63-593	47 M OHM			

PHONOGRAPH OSCILLATOR
 ZENITH RADIO CORPORATION
 CHICAGO ILL.

TO 3RD WIRE IN A.C. CORD

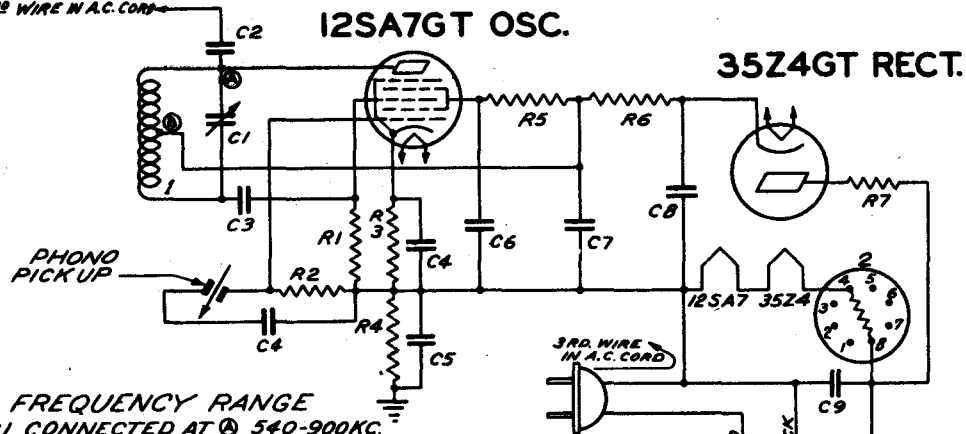

FREQUENCY RANGE
 C1 CONNECTED AT ① 540-900K.C.
 C1 CONNECTED AT ② 900-1500K.C.

MODEL
 S9000

DIAG. N ^o	PART N ^o	DESCRIPTION	DIAG. N ^o	PART N ^o	DESCRIPTION
C1	22-690	TUNING CONDENSER	R3	63-701	470 OHM 1/4 W.
C2	22-127	25 MMFD.	R4	63-296	220M OHM 1/4 W.
C3	22-182	.00025 MFD.	R5	63-964	4700 OHM 1/2 W.
C4	22-829	.05 MFD.	R6	63-803	2200 OHM 1/2 W.
C5	22-827	.1 MFD.	R7	63-575	47 OHM 1/4 W.
C6	22-243	.01 MFD.			
C7	22-876	8 MFD. ELECTROLYTIC	1	58611	OSC. COIL ASSEM.
C8	22-876	40 MFD. "	2	100-76	CALLAST TUBE
C9	22-828	.05 MFD.	3	52-208	3 PRONG RECEPTACLE
R1	63-591	22 M OHM			
R2	63-271	1 MEG OHM			

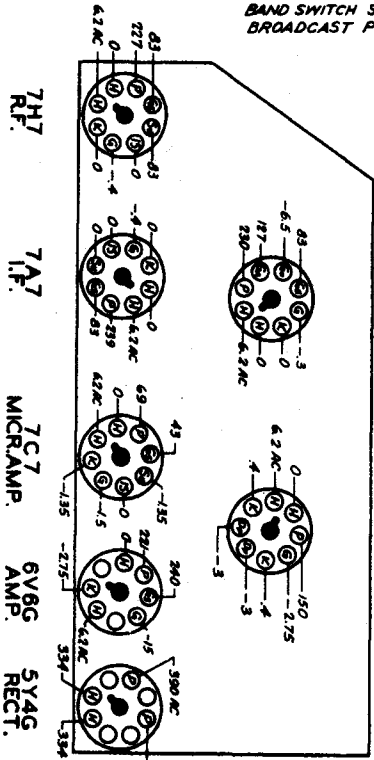
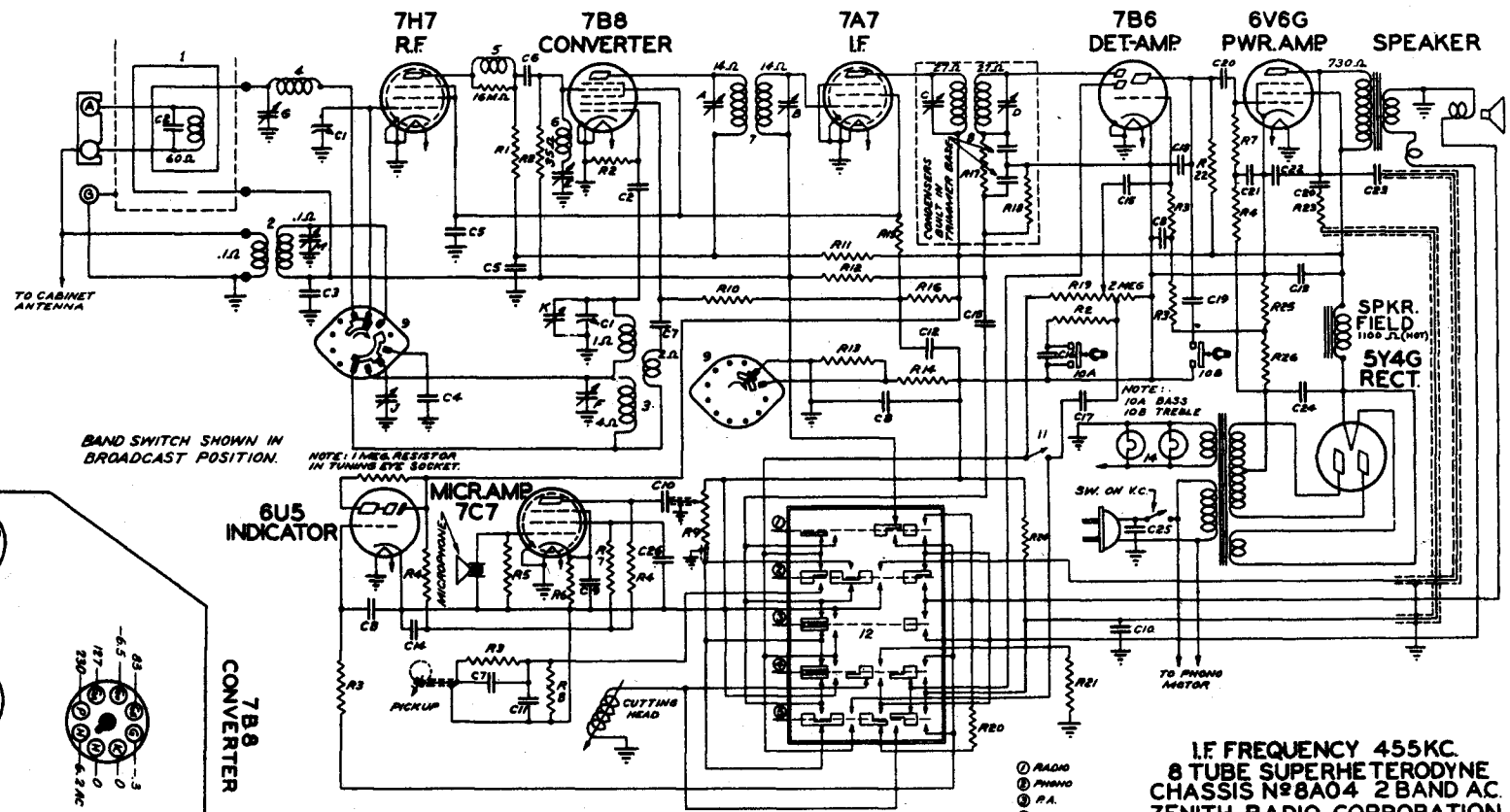

Circuit Diagram
Models 8S593-8S594
Chassis No. 8A04

NOTE: ALL BUTTONS SHOWN IN NON-OPERATED POSITION.

- ① RADIO
- ② PHONO
- ③ P.A.
- ④ RECORD MICR.
- ⑤ RECORD RADIO

I.F. FREQUENCY 455 KC.
 8 TUBE SUPERHETERODYNE
 CHASSIS #8A04 2 BAND AC.
 ZENITH RADIO CORPORATION
 CHICAGO, ILL.

DIAG. NO.	PART NO.	DESCRIPTION	DIAG. NO.	PART NO.	DESCRIPTION	DIAG. NO.	PART NO.	DESCRIPTION	DIAG. NO.	PART NO.	DESCRIPTION		
C1	22-284	TWO BAND VARIABLE	C23	22-1119	.005 MFD.	1000K	R17	63-713	47M OHM	14W	10	58831	TONE CONTROL SWITCH
C2	22-209	.50M MFD.	C24	22-1036	14 MFD. ELECTROLYTIC	450K	R18	63-719	470M OHM	14W	11	95-134	NORMAL-BRILLIANT SWITCH
C3	22-229	.05 MFD.	C25	22-1041	.005 MFD.	600K	R19	63-1123	VOLUME CONTROL	14W	12	95-259	RECORDER UNIT CONTROL SW.
C4	22-1082	.005 MFD.	C26	22-285	.1 MFD.	400K	R20	63-1108	5 OHM WIREWOUND	2 W	13	95-756	POWER TRANS. 117V 50-60~
C5	22-282	.05 MFD.				400K	R21	63-1139	8 OHM "	3 W	14	100-36	PILOT LIGHT 6.3K .25A.
C6	22-162	.0001 MFD.	R1	63-627	4700 OHM	14W	R22	63-296	250M OHM	14W	A		121 I.F. TRANS. PRI.
C7	22-182	.00025 MFD.	R2	63-591	47M OHM	14W	R23	63-778	470M OHM	14W	B		121 I.F. SEC.
C8	22-221	.1 MFD.	R3	63-271	1 MEG OHM	14W	R24	63-790	6.7 MEG OHM	14W	C		228 I.F. PRI.
C9	22-1089	20 MFD. ELECTROLYTIC	R4	63-593	100M OHM	14W	R25	63-1066	18 OHM WIREWOUND	14W	D		228 I.F. SEC.
C10	22-492	.002 MFD.	R5	63-602	4.7 MEG OHM	14W	R26	63-1083	140 OHM	1 W	E	22-1005	WAVE TRAP
C11	22-487	.001 MFD.	R6	63-238	1000 OHM	14W					F	22-959	BROADCAST OSC.
C12	22-1039	15 MFD. ELECTROLYTIC	R7	63-597	470M OHM	14W					G	22-1042	BROADCAST ANT.
C13	22-1039	15 MFD. "	R8	63-650	68M OHM	14W					H	22-1009	BROADCAST Padder
C14	22-180	.02 MFD.	R9	63-1146	VOLUME CONTROL	14W	1	38507	WAVEMAGNET ASSEMBLY		M	22-1006	SHORT WAVE ANT.
C15	22-180	.02 MFD.	R10	63-150	10M OHM	14W	2	38507	ANTENNA COIL				
C16	22-1118	.005 MFD.	R11	63-599	1000 OHM	14W	3	28982	OSCILLATOR COIL				
C17	22-285	.0005 MFD.	R12	63-599	15 MEG OHM	14W	4	58474	LOOP LANDING COIL				
C18	22-285	.0005 MFD.	R13	63-599	15 MEG OHM	14W	5	58759	COIL & RES. ASSEMBLY				
C19	22-460	.004 MFD.	R14	63-624	68 OHM	14W	6	31326	WAVE TRAP				
C20	22-330	.02 MFD.	R15	63-709	42 OHM WIREWOUND	14W	7	35-109	121 I.F. TRANSFORMER				
C21	22-329	.02 MFD.	R16	63-1102	15M OHM	14W	8	35-781	228 I.F.				
C22	22-790	.004 MFD.	R16	63-1101	2200 OHM	2 W	9	95-259	BAND SELECTOR SWITCH				

FOREWORD TO DICTIONARY

The need of simple but accurate definitions of commonly used Radio and Electrical terms has existed as long as the Industries themselves. The Coyne Electrical School has made this Dictionary a part of the Coyne Electrical Trouble Shooting Manual for two very good reasons.

FIRST: A knowledge of the exact meaning of an expression or term will help a beginner, whether he be a student, an experimenter or any one else interested in the field to speed his progress and broaden his knowledge.

SECOND: The "old timer" also has need of an authoritative dictionary to serve as a reference guide on the precise meaning of many new Electrical and Radio terms. It enables him to be the authority in his plant.

This section contains over 1100 easy to understand definitions, abbreviations and terms most likely to be encountered in Radio or Electrical work. It also includes schematic symbols, tips on reading circuit diagrams and other useful information.

Whether you are a "beginner" or an "old timer" this Dictionary will be at your side whenever you need it. Get to learn the language of Electricity and Radio better by referring constantly to this section of your Trouble Shooting Manual.

We especially thank the Allied Radio Corporation, of Chicago, for their cooperation in helping us to prepare this valuable Electrical and Radio Dictionary.

A DICTIONARY OF ELECTRICAL, RADIO AND ELECTRONIC TERMS

A

A- (A negative or A minus.) Symbol used to designate the point in a circuit to which the negative terminal of the filament supply is to be connected.

A+ (A positive or A plus.) Symbol used to designate the point in a circuit to which the positive terminal of the filament supply is to be connected.

A BATTERY. The battery (often a single dry cell) used for supplying heating current to the filaments of radio tubes.

AB POWER PACK. A combination of batteries or devices in a single housing, used to supply potentials for receivers, especially portable sets.

A.C. Alternating current.

ACOUSTIC. Pertaining to sound.

ACOUSTIC FEEDBACK. Transfer of sound waves from a loudspeaker to any previous part, such as a microphone, in the same amplifying or broadcasting system. It can cause howling and overloading of tubes.

A.C.-D.C. RECEIVER. A receiver which will operate either from an a.c. or d.c. power source. It does not have a power transformer.

A.C. RECEIVER. A receiver designed to operate only from an a.c. power source. Power packs of these sets invariably employ a power transformer for stepping the a.c. line voltage up and down.

ACTIVE LINES. Periods during which the electron beam exists or is active in a television camera tube or picture tube, and is either scanning or else reproducing the lights and shades of the picture.

ADAPTER. Any device used for changing temporarily or permanently the terminal connections of a circuit or part.

ADJUSTABLE SPEED MOTOR. A motor whose speed may be varied gradually over a considerable range, and which then remains practically unaffected by changes in load.

ADMEDIUM LAMPHOLDER. A lampholder having a nominal screw diameter of 1 1/16 inch.

ADMITTANCE. The measure of ease with which an alternating current flows

in a circuit. The reciprocal of impedance. Measured in micromhos (mhos.).

AERIAL. An antenna.

A.F. Audio frequency.

AIR-CELL A BATTERY. A non-rechargeable wet-cell battery which usually is built to deliver 2 volts, for use chiefly in battery-operated home radio receivers. Its carbon electrodes are porous and absorb oxygen from the air during use. Rated life in normal radio use is 500 to 1500 hours, depending upon battery size and current drain.

AIR CORE. A term used to describe coils or transformers which have no iron in their magnetic circuits. Air-core construction is used chiefly in r.f. circuits.

AIR GAP. A path for electrical or magnetic energy through air between two objects, such as between the electrodes of a spark gap or between core sections of an iron-core transformer.

AIRPLANE DIAL. Popular name for a circular-shaped radio receiver dial with a rotating pointer, resembling the dials and pointers of airplane instruments.



Non-Metallic Screwdriver

TYPE OF ALIGNING TOOLS

ALIGNING TOOL. An essentially non-metallic screwdriver or socket wrench used for adjusting the trimmer condensers and adjustable coils which are provided in radio receivers for aligning purposes or for pre-setting push-button tuners.

ALKALI-TYPE BATTERY. A storage battery using an alkaline or non-acid liquid electrolyte; an Edison battery.

ALLIGATOR CLIP. A long-nose clip with spring-controlled meshing jaws used on test leads for making quick temporary connections.



ALL-METAL TYPE TUBE. A vacuum tube having a metal envelope instead of a glass envelope. Electrode connections are made through glass beads fused into the top and bottom of the metal envelope. The octal bakelite base is designed to take eight equally spaced

terminal prongs, but some of the prongs are omitted on tubes having less than eight terminals.

ALLOY. A mixture of two or more metals.

ALL-WAVE ANTENNA. A receiving antenna designed to pick up stations reasonably well over a wide range of carrier frequencies including short-wave bands as well as the broadcast band. It may be a single doublet antenna or a combination of two or more doublets.

ALL-WAVE RECEIVER. A receiver capable of receiving stations on all of the commonly used wavelengths in short-wave bands as well as the broadcast band.

ALTERNATING CURRENT. An electric current which reverses its direction of flow at regular intervals many times per second.

ALTERNATION. One-half of a cycle of alternating current, during which the current rises from zero to maximum value and returns to zero.

ALTERNATOR. A generator which produces alternating current.

A.M. Amplitude modulation. Also written as a-m or AM.

AMALGAMATE. To combine mercury with another metal, as on the surface of battery electrodes or plates.

AMATEUR. Any person who operates and experiments with short-wave transmitters as a hobby rather than for profit.

AMATEUR BANDS. Bands of frequencies assigned exclusively to radio amateurs by the Federal Communications Commission. Amateur band limits are:

1,715 to 2,000 kc.	28,000 to 30,000 kc.
3,500 to 4,000 kc.	56,000 to 30,000 kc.
7,000 to 7,300 kc.	112,000 to 116,000 kc.
14,000 to 14,000 kc.	224,000 to 230,000 kc.

Amateurs may also operate on any frequency above 300,000 kc.

AMATEUR OPERATOR. A person holding a valid license issued by the F.C.C. authorizing him to operate licensed amateur stations.

AMATEUR STATION. A radio station used by an amateur for personal communication with other amateurs.

AMATEUR STATION CALL LETTERS. Identifying call signal assigned to a licensed amateur operator to identify his station. Amateur calls in a given country begin with a one or two-letter prefix (W or N for U.S., and K for U.S. possessions), followed by a location-indicating numeral and two or more additional letters.

AMERICAN MORSE CODE. A dot-and-dash code which is commonly used for telegraphic communication over wires. It differs considerably from the International Morse Code which is used in radio.

AMMETER. An instrument used for measuring the current flow in amperes in a circuit.

AMP. Ampere.

AMPERE. The practical unit of electric current flow. The movement of 6,280,000,000,000,000 electrons past a given point in a circuit in one second con-

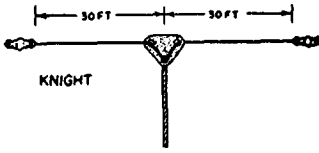
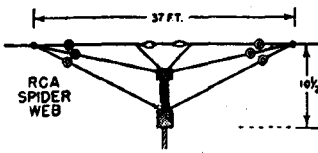
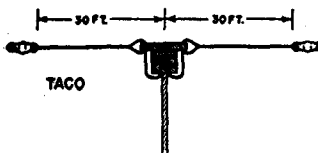
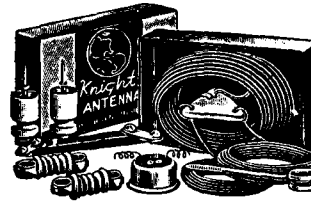
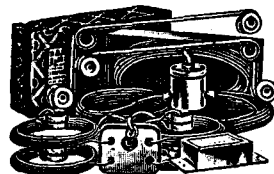
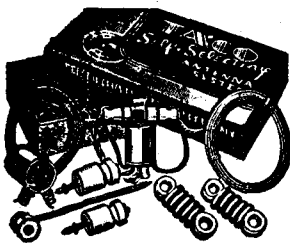

TYPES OF ALL-WAVE ANTENNAS

responds to a current of one ampere. When a one ohm resistance is connected to a one volt source, one ampere will flow.

AMPERE-HOUR. A current of one ampere flowing for one hour. This unit is used chiefly to indicate the amount of electrical energy a storage battery can deliver before it needs recharging.

AMPERE-TURN. A unit of magnetizing force, equal to the number of amperes of current multiplied by the number of turns of a winding in which it flows.

AMPLIFICATION. The process of increasing the strength (current, voltage or power) of a signal. Amplification can be provided by transformers and tuned circuits as well as vacuum tubes.

AMPLIFICATION FACTOR. A vacuum tube rating indicating the theoretical maximum increase in signal strength which can be provided by a given tube.

AMPLIFIER. A device consisting of one or more vacuum tubes and associated parts, used to increase the strength of a signal.

AMPLIFY. To increase in strength.

AMPLITUDE MODULATION. The common system of radio broadcasting, in which the deviation in frequency above and below the assigned carrier frequency value is equal to the frequency of the sound wave being transmitted, and the amplitude of the transmitted signal varies in accordance with the instantaneous amplitude of the sound wave being transmitted. Abbreviated as a.m., or a-m or AM.

ANALYZER. A test instrument used for checking radio parts and circuits. It sometimes includes a special plug-in system which can be inserted in a tube socket to extend the socket terminal to the instrument for convenience in making measurements.

ANODE. The radio tube electrode to which the main electron stream flows. The anode is also called the plate, and is usually placed at a high positive potential with respect to the cathode. It is usually identified on diagrams by the letter P.

ANT. Antenna.

ANTENNA. A metallic structure or an arrangement of conducting wires or rods used for picking up or radiating radio waves. Also known as an aerial.

ANTENNA COIL. That coil in a radio receiver through which the antenna current flows. This coil is usually directly connected to the antenna and ground terminals inside the set.

APPARENT POWER. The product of volts and amperes in an alternating-current circuit whose voltage and current are not in phase, in a circuit containing inductance, capacitance or both. Measured in volt-amperes.

APPLIANCE. Stationary or portable power-consuming equipment such as heating devices, cooking devices, and small motor-driven equipment.

ARMATURE. Usually the movable portion of a magnetic circuit, such as the

rotating section of a generator or motor, the pivoted iron portion of a magnetic loudspeaker, or the spring-mounted iron portion of a buzzer or relay.

ARTIFICIAL GROUND. A grounding electrode consisting of a metal plate, pipe or rod buried in the earth.

ARTIFICIAL MAGNET. A magnet made of iron or steel which has been magnetized, as distinct from a lodestone or natural magnet.

ASPECT RATIO. In television, a numerical ratio equal to picture width divided by picture height.

ATMOSPHERIC INTERFERENCE. Crackling and hissing noises reproduced in the radio loudspeaker due to electrical disturbances occurring in the atmosphere surrounding the earth; these disturbances radiate electro-magnetic waves which are picked up by antenna systems of receivers. Also called static interference, and particularly noticeable during thunderstorms.

ATOM. One of the elemental particles into which all matter is divided. An atom has a nucleus consisting of electrons and protons, with additional electrons revolving around the nucleus. Each of the 93 known elements has a different number and arrangement of electrons and protons in its atoms.

ATTENUATION. Reduction in the strength of an electrical impulse.

AUDIBLE. Capable of being heard by the human ear.

AUDIO AMPLIFIER. A vacuum tube device which increases the voltage and power of an audio frequency signal. It may be a separate piece of equipment or a section in a radio receiver.

AUDIO FREQUENCY. A frequency corresponding to an audible sound wave. The extreme limits of audio frequencies vary with the individual and are from about 20 cycles to about 20,000 cycles per second.

AUDIO TRANSFORMER. An iron-core transformer used for the dual purpose of coupling together two audio amplifier circuits and changing the value of an audio signal.

AUDIO OSCILLATOR. An oscillator which generates audio frequency voltages.

AUTOMATIC BASS COMPENSATION. A special resistor and condenser circuit used in some radio receivers to make low audio frequency notes sound more natural at low volume control settings. The circuit automatically compensates for the poor response of the human ear to weak low-frequency sounds.

AUTOMATIC BRIGHTNESS CONTROL. A circuit which automatically keeps the average brightness of the reproduced image constant in a television receiver.

AUTOMATIC FREQUENCY CONTROL. A special radio circuit which keeps a superheterodyne receiver tuned accurately to a given station. It is found chiefly on push-button tuned

receivers, where it corrects slight inaccuracies in the operation of the automatic tuning system.

AUTOMATIC RECORD CHANGER.

An electric phonograph which automatically plays a number of records one after another.



Some types play only one side of each record, while others are arranged to turn each record over and play both sides.

AUTOMATIC TUNING. An electrical, electro-mechanical or mechanical system which tunes a radio receiver automatically to a predetermined station when a button or lever is pushed.

AUTOMATIC VOLUME CONTROL. A radio circuit which automatically maintains the output value of a radio receiver constant within limits while the antenna signal picked up by the antenna is varying in amplitude over a wide range. It is used in practically all modern receivers, for it minimizes annoying fading of distant stations and prevents blasting when tuning suddenly from a weak station to a strong station.

AUTOMATIC VOLUME EXPANSION. A special audio circuit which increases the volume range of a radio program or phonograph record by making the weak passages weaker and making loud passages louder.

A.V.C. Automatic volume control.

AVERAGE VALUE. A voltage or current found by adding together a large number of instantaneous values and dividing by the number of values. In an alternation of sine wave form the average value is 0.636 times the maximum value.

AVIATION CHANNELS. Frequency bands assigned to aviation service for radio communication between aircraft and ground stations. These bands are both above and below broadcast band frequencies.

B

B—. (B negative or B minus.) Symbol used to designate the point in a circuit to which the negative terminal of the plate supply is to be connected.

B+. (B positive or B plus.) Symbol used to designate the point in a circuit to which the positive terminal of the plate supply is to be connected.

BACK EMF. Same as counter emf.

BACKGROUND NOISE. Noise heard along with a received radio program, due to atmospheric interference or to circuit conditions.

BAFFLE. A wood, metal or composition horn or flat surface used with a loudspeaker to increase the length of the air path from the front to the back of the loudspeaker diaphragm, thereby reducing interaction between sound waves produced simultaneously by front and back surfaces of the diaphragm. A baffle thus serves to direct the sound produced by a loudspeaker

and improve the fidelity of reproduction.

BAKELITE. A phenolic compound having high electrical resistance, used as an insulating material in the construction of radio parts such as panels, coil forms, tube sockets, etc.

BALANCED ARMATURE UNIT. An electro-magnetic sound-producing device used chiefly in magnetic loudspeakers. It has a small moving iron armature which is surrounded by windings carrying audio currents. The armature is pivoted between the poles of a permanent magnet. Variation in the audio current cause corresponding changes in magnetism, making the armature rock back and forth. A diaphragm coupled to the armature produces sound waves.

BALLAST RESISTOR. A special type of resistor used in radio apparatus to compensate for fluctuations in a.c. power line voltage. It is usually connected in series with the power supply to the receiver or amplifier. The ohmic value of a ballast resistor increases automatically with increases in current through it, thereby tending to maintain essentially constant current despite variations in line voltage.

BALLAST TUBE. A ballast resistor mounted in an evacuated glass or metal envelope. This construction improves the automatic voltage regulating action by reducing radiation of heat from the resistor element.

BAND. In radio, frequencies which are within two definite limits and are used for a definite purpose. Thus, the standard broadcast band extends from 550 kc. to 1600 kc.

B. & S. GAUGE. Brown and Sharpe wire gauge, the standard gauge used in the United States to specify wire sizes.

BAND SWITCH. A switch which simultaneously changes all tuning circuits of a radio receiver or transmitter to a desired band of frequencies.

BANDSPREAD TUNING CONTROL. A small variable condenser connected in parallel with the main tuning condenser of a short-wave receiver to provide more accurate tuning.

BANTAM TUBE. A compactly designed tube having a standard octal base but a considerably smaller glass envelope than does a standard glass tube. Bantam tubes are used chiefly in compact table model receivers and in battery-operated portable sets.

BANTAM JR. TUBE. An extremely small glass vacuum tube with a special bantam jr. base, used chiefly in hearing aid units.

BASS. Low audio frequencies.

BASS CONTROL. A manually-adjusted control provided on a radio receiver for the purpose of emphasizing the loudness of the bass notes in a radio program.

BASS COMPENSATION. Any means of offsetting the natural drop in the response of the human ear to low audio frequencies at low volume levels.

BASS RESPONSE. The ability of a loudspeaker to handle low audio notes,

or the sensitivity of the human ear to low audio notes.

BATTERY. One or more dry cells or storage cells connected together to serve as a d.c. voltage source.

BATTERY RECEIVER. A receiver which uses batteries as a power source.

BAYONET BASE. A type of tube and lamp base having two projecting pins on opposite sides of the smooth cylindrical base; these engage in corresponding slots in the bayonet shell socket.



B BATTERY. A battery having many small cells connected in series, used for supplying d.c. voltages to the plate and screen grid electrodes of radio tubes used in battery-operated equipment.

BEAM POWER AMPLIFIER TUBE. A special type of vacuum tube designed for use in the output stage of a radio receiver. Deflecting electrodes concentrate the electrons into beams to give high power output along with desirable operating characteristics.

BEAT FREQUENCY. The frequency obtained when signals of two different frequencies are combined and rectified. The beat frequency is equal in numerical value to the difference between the original frequencies.

BEAT FREQUENCY OSCILLATOR. An audio frequency oscillator whose output is obtained by combining and rectifying two known higher-frequency signals which are generated by or obtained from separate circuits.

B ELIMINATOR. An a.c. power pack which converts a.c. power line voltage to the pure d.c. circuits of radio tubes, thereby eliminating the need for B batteries.

BELL WIRE. A common term for the cotton-covered B. & S. No. 18 copper wire used for making doorbell and thermostat connections in homes.

BIAS. The fixed voltage applied between the control grid and cathode electrodes of a radio tube. Also called C bias.

BIAS CELL. A tiny 1-volt or 1½-volt cell used singly or in series to provide a negative C bias voltage for a vacuum tube amplifier circuit. It will last indefinitely if not overloaded.



BIPOLAR. Having two magnetic poles, one north and the other south. Two-pole.

BLACK LEVEL. The steady level of television carrier current or voltage while not modulated by any of the signals. The base or starting value above which rise the synchronizing and equalizing voltages of the television signal.

BLANKING SIGNAL. The portion of a television signal that blanks or extinguishes the electron beam in the picture tube of the receiver while the beam is being blanked in the camera tube at the transmitter.

BLASTING. Overloading of an amplifier or loudspeaker, resulting in severe distortion of loud sounds.

BLEEDER CURRENT. A current drawn continuously from a power pack to improve its voltage regulation or to increase the voltage drop value across a particular resistor.

BLEEDER RESISTOR. A resistor which is used to draw a fixed bleeder current value from a power pack.

BLOCKING CONDENSER. Any condenser used in a radio circuit to block the flow of direct current while allowing a.c. signal currents to pass.

BLOOPER. Slang term applied to a regenerative receiver which radiates a signal when improperly tuned.

BODY CAPACITY. The capacity existing between the human body and a piece of radio apparatus.

BOND. A connection between metallic parts which makes them a continuous electrical conductor.

BONDING. Connecting the metal housings and shields of radio parts together or to the chassis with heavy wire so they will be at the same potential (usually ground potential.)

BRANCH CIRCUIT. The portion of a wiring system that extends beyond the final overcurrent device (fuse, cutout or circuit breaker) that protects the circuit. The portion of the circuit leading to lamps, appliances and other power-consuming equipment.

BREAKDOWN VOLTAGE. The voltage at which the insulation between two conductors will break down and become conductive.

BRIGHTNESS CONTROL. In a television receiver, the control which varies the average illumination of the reproduced image.

BROADCAST. A radio transmission intended for reception by the general public.

BROADCASTING. A general term applying to the radiation of radio waves carrying programs intended for public interest, education, or entertainment.

BROADCAST BAND. The band of frequencies between 550 kc. and 1600 kc., to which are assigned all standard broadcast stations operating in the United States.

BROADCAST STATION. A radio station used for transmitting programs to the general public.

BROAD TUNING. A condition wherein two or more stations are picked up at one setting of a receiver tuning dial, due to lack of selectivity in the tuning circuits.

BRUSH. A stationary conductor held in contact with a moving conductor or conductors to allow flow of current between stationary and moving parts of electrical equipment.

BUCK. To oppose.

BUFFER. Any part or circuit used to reduce undesirable interaction between radio circuits.

BUFFER CONDENSER. A condenser connected between the anode and cathode of a cold-cathode rectifier tube to reduce voltage surges which might affect following parts in the apparatus.

BUFFER STAGE. An amplifier stage used to prevent feed-back of energy from a power stage to a preceding stage.

BUG. A semi-automatic code transmitting key in which movement of a lever to one side produces a series of dots, and

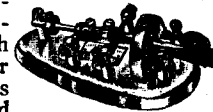

movement to the other side produces a single dash.

BUILT-IN AERIAL. An aerial which is an integral part of a radio receiver. It may be a loop aerial, a power line connection or a sheet of metal mounted in the receiver cabinet.

BUSWAY. A protective enclosure for buses, which are conductors formed by bars or rods of large cross section.

BUZZER. An electromagnetic device in which attraction of an armature by an electro-magnet interrupts the current flow; a spring then pulls the armature back, closing the circuit again so that the process repeats itself and creates a buzzing sound.

BX. Flexible metal conduit used to protect power line wiring in buildings and in high-power radio apparatus.

BY-PASS CONDENSER. A condenser used to provide a low-impedance path for radio or audio signals around a resistor or between a circuit terminal and ground.

C

C. Letter used to designate a condenser, a grid bias voltage, or the centigrade temperature scale.

C- (C negative or C minus.) Symbol used to designate the point in a vacuum tube circuit to which the negative terminal of the grid bias source is to be connected.

C+ (C positive or C plus.) Symbol used to designate the point in a vacuum tube circuit to which the positive terminal of the grid bias source is to be connected.

CABINET. An enclosure for switches fuses and wire connections, designed for either surface or flush mounting and having a frame or trim on which are hung swinging doors.

CABLE. A stranded conductor (called a single-conductor cable) or a combination of conductors insulated from one another (called a multiple-conductor cable).

CADMIUM. A metal sometimes plated on a steel chassis to improve its appearance and prevent rusting.

CALL LETTERS. Government-assigned identifying letters for a radio station.

CAM. An irregular-shaped rotating or sliding part used to convert rotary motion to linear motion, or vice versa. Used extensively in mechanical push-button tuning systems.

CANDELABRA LAMPHOLDER. A lampholder having a nominal screw diameter of $\frac{1}{2}$ inch.

CAPACITANCE. Electrostatic capacity.

CAPACITIVE REACTANCE. The effect of capacitance in opposing the flow of alternating or pulsating current.

CAPACITOR. Condenser.

CAPACITOR. A condenser or an electrostatic condenser.

CAPACITOR MOTOR. A split-phase motor in which a capacitor or capacitors displace part of the current in phase from the remainder in order that the motor may be self-starting on single-phase supply current.

CAPACITY. The electrical size of a condenser, determining the amount of electrical energy which can be stored in a condenser by a given voltage. In radio work, capacity is measured in microfarads (mfd.) and micro-microfarads (mmfd.); 1 mfd. is equal to 1,000,000 mmfd.

CAPACITIVE COUPLING. A type of coupling in which a condenser provides a direct path for signal energy between two circuits.

CAPACITIVE REACTANCE. The reactance which a condenser offers to a.c. or pulsating d.c. It is measured in ohms, and decreases as frequency and capacity are increased.

CARBON. An element used in the construction of radio parts such as resistors, dry cells, and microphones.

CARBON RESISTOR. A resistor made of carbon particles and a ceramic binder molded into a cylindrical shape, with leads attached to opposite ends.

CARBORUNDUM. A compound of carbon and silicon used in crystal form to rectify or detect radio waves, as in a crystal detector.

CARRIER. A current, voltage or radio wave having the assigned frequency of a radio station. When no sounds are being transmitted, such as during a pause between portions of a program, only the unmodulated carrier signal is present in the transmitting and receiving system.

CARRIER FREQUENCY. The frequency of the original unmodulated radio wave produced by a transmitter. In the case of a broadcast station, the carrier frequency must be maintained within a few cycles of the frequency value assigned to that station by the Federal Communications Commission.

CARTRIDGE FUSE. A fuse enclosed with an insulating and protective covering and provided with connections at its ends.

CATHODE. The electron-emitting electrode of a radio tube. Thermionic vacuum tubes employ heated cathodes; the heat is either supplied indirectly by a filament located inside the cathode or is supplied by current flowing through the cathode itself. In this latter case, the cathode is also the filament.

CATHODE RAY. A ray or beam of electrons emitted from a cathode.

CATHODE RAY TUBE. A special type of vacuum tube in which a beam of electrons is directed at a fluorescent screen by an electron gun, producing a green or white glow on the screen at the point of impact. The beam passes between electrostatic deflecting plates or electromagnetic deflecting coils which can make it bend enough to produce any desired pattern or pic-

ture on the screen when the proper varying voltages are applied to the deflecting system.

CATHODE RAY TELEVISION TUBE. The cathode ray tube used in modern television receivers to reproduce the scenes being transmitted.

CATHODE RAY TUNING INDICATOR. A small cathode ray tube used in radio receivers to indicate when a station is tuned in accurately.

CATHODE RAY OSCILLOSCOPE. A test instrument using a cathode ray tube to make visible the wave form of a varying current or voltage.

CATWHISKER. A small, sharply pointed wire used in crystal detector to make contact with a sensitive point on the surface of the crystal.

C BATTERY. The battery used for supplying a negative C bias to the control grid of a vacuum tube.

C BIAS. An applied voltage used to bake the control grid of a vacuum tube negative with respect to the cathode.

CELL. A single unit capable of serving as a d.c. voltage source. A primary cell, such as a dry cell, cannot be recharged when exhausted. A secondary cell, such as the cell of a storage battery, can be recharged when exhausted by passing a current through it in the reverse direction.

CENTERING CONTROL. In a television receiver, a control used to shift the entire reproduced image on the screen. The horizontal centering control moves the image horizontally in either direction, while the vertical centering control shifts the image up or down.

CENTIGRADE. The European scale of temperature in which 0 is the temperature of melting ice and 100 is the temperature of boiling water at sea level.

CENTIMETER. In the metric system of measurements, a unit equal to one-hundredth of a meter, or approximately .39 inch. There are 2.54 centimeters in one inch.

CHAIN. In radio, a network of radio stations connected together by special telephone lines so that all can broadcast simultaneously a program originating at a key station.

CHANNEL. A narrow band of frequencies including the assigned carrier frequency, within which a radio station is required to keep its modulated carrier signal in order to prevent interference with stations on adjacent channels. Also, one branch or path over which radio signals may travel; thus, a p.a. system may have several input channels, each with its own sound pick-up device, transmission line and volume control.

CHARGE. A quantity of electrical energy held on an insulated object. The electrical energy stored in a condenser. The act of supplying electrical energy to a metal object, to a condenser, or to a storage battery. When an object has more electrons than normal, it has a negative charge. When an object has less electrons than normal, it has a positive charge.

CHARGER. A device used to convert alternating current into a pulsating direct current which can be used for charging an exhausted storage battery.

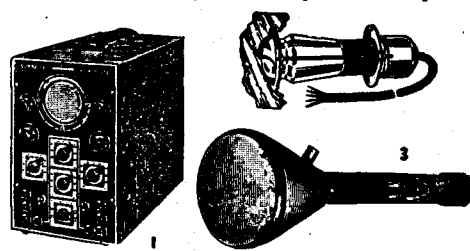

(1) Cathode Ray Oscilloscope.
(2) Cathode Ray Tuning Indicator.
(3) Cathode Ray Television Tube.

CHASSIS. The metal framework on which the parts of a radio receiver or transmitter are mounted. Also used to designate the completed piece of radio equipment before it is mounted in a cabinet.

CHOKE COIL. A coil used to limit the flow of alternating current while allowing direct current to pass. R.F. choke coils have air or pulverized iron cores, while a.f. choke coils and filter chokes have iron cores.

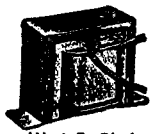

(1) A.F. Choke.

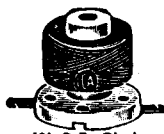

(2) R.F. Choke.

CIRCUIT. A complete path over which an electric current can flow.

CIRCUIT BREAKER. A device for automatically opening a circuit in case of over-current in this or another circuit, and sometimes for opening the circuit in case of under-voltage.

CIRCUIT VOLTAGE. The greatest effective difference of potential between any two conductors in the circuit considered.

CLIP. A small spring-type clamp having any of several different designs, used for making a readily removable connection to a terminal.

CLOCKWISE. The direction in which the hands of a clock move.

COAXIAL CABLE. A two-conductor cable in which one conductor is a flexible or non-flexible metal tube and the other is a wire centrally supported inside the tube by insulators.

CM. Centimeter.

CODE. A system of dot and dash signals used in the transmission of messages by radio or wire telegraphy. The International Morse Code (also called the Continental Code) is used everywhere for radio telegraphy. The American Morse Code is used commonly for wire telegraphy.

CODE RECORDER. An instrument which makes a permanent record of code messages received by radio or otherwise.

COIL. A number of turns of wire wound on an iron core or on a coil form made of insulating material. A coil offers considerable opposition to the passage of alternating current but very little opposition to direct current.

COIL FORM. The tubing or solid object on which a coil is wound. It can have any shape and can be made from any insulating material, such as paper, cardboard, fiber, bakelite, a plastic or ceramic materials, or wood.

COLD CATHODE. A cathode which does not depend upon heat for electron emission. The cold cathode of a photoelectric tube emits electrons when exposed to light, while in a type BH rectifier tube the electrons are pulled out of the cold cathode by a sufficiently high voltage applied to the pointed anode.

COLLECTOR RINGS. Continuous metallic rings on a rotating member, against which bear stationary brushes to allow current flow between the rotating and stationary parts of the equipment.

COLOR CODE. Any system of colors used to specify the electrical value of a radio part or identify terminals and leads.

COMMUNICATION RECEIVER. A receiver designed especially for reception of code or voice messages transmitted by short-wave radio communication services.

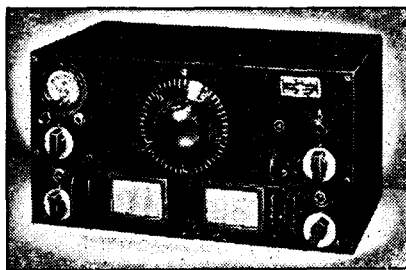

COMMUTATION. Conversion of alternating current generated in the armature of a direct-current machine to direct current for the external circuit.

COMMUTATOR RIPPLE. Small pulsations in the voltage and current taken from a direct-current generator.

COMPOUND MAGNET. A permanent magnet consisting of several similarly shaped single magnets in close contact and with like poles together.

CONCENTRIC CABLE. Coaxial cable.

CONDENSER. A radio part consisting of two conducting surfaces separated from each other by an insulating material such as air, oil, paper, glass or mica. A condenser is capable of storing electrical energy. In radio circuits, condensers are used to block the flow of direct current while allowing alternating and pulsating currents to pass. The electrical size or capacity of a condenser is specified in microfarads and micro-microfarads.

CONDUCTIVITY. The ability of a material to carry electric current.

CONDUCTOR. Any substance in which a difference of voltage between two points causes current to flow between these points. One or more wires carrying a single current.

CONDUCTOR. A wire or other metal structure which provides a path for electric current between two points. A conductor is thus a material which offers little opposition to the continuous flow of electric current.

CONE. The conical-shaped paper or fiber diaphragm of a magnetic or dynamic loud-speaker.

CONNECTOR. A device for joining electrical conductors either by soldering or by mechanical pressure applied with screws.

CONSOLE. A large radio receiver cabinet, designed to rest on the floor rather than on a table.

CONTACT. A terminal to which a connection can be made. A joining of bodies to permit the flow of electrical current.

CONTACTOR. A magnetically operated switch for opening and closing circuits carrying large currents.

CONTINENTAL CODE. Same as the International Morse Code. Used universally for radio telegraphy.

CONTRAST CONTROL. In a television receiver, a manual control which adjusts the range of brightness between highlights and shadows of the reproduced image.

CONTROL GRID. That electrode in a vacuum tube which has the most effective control over the plate current passed by the tube. The control grid is usually the electrode nearest to the cathode.

CONTROL PANEL. An exposed or enclosed upright panel carrying switches and other controlling, measuring and protective devices for electrical machinery or equipment.

CONVERTER. That section of a superheterodyne radio receiver which changes incoming modulated r.f. signals to a lower frequency known as the i.f. value; the converter section includes the oscillator and the first detector. Also, a device, usually rotary, changing electrical energy from one form to another, as AC to DC.

COPPER-OXIDE RECTIFIER. A rectifier made up of discs of copper coated on one side with cuprous oxide. The discs allow direct current to flow in one direction but allow very little current flow in the reverse direction.

CORE. The center of a coil.

COUNTER-CLOCKWISE. In a direction opposite that in which the hands of a clock rotate.

COUNTER EMF. In a circuit containing self-inductance, a voltage produced by changes of current and which at every instant opposes the change of current that produces the voltage.

COUNTERSINK. To ream, drill or cut a conical depression around a hole for a flat-head screw, so that the screw head will be flush with the surface of the work.

COUPLING. The means by which signals are transferred from one radio circuit to another. Coupling can be direct through a conductor, electro-static through a condenser, or inductive through a transformer. Also, a connecting device.

COUPLING. Any means by which electrical energy is transferred from one circuit to another, with changes of voltage or current in one circuit producing corresponding changes in the other.

C.R.O. Cathode ray oscilloscope.

CRYSTAL. A piece of natural quartz or similar piezo-electric material which has been ground to a size which will vibrate naturally at a desired radio frequency and generate that frequency when set into vibration. A quartz crystal is used in radio transmitters to generate with a high degree of accuracy the assigned carrier frequency of a station, and is used in crystal filters of radio receivers to improve the selectivity of the i.f. amplifier. The mineral used in a crystal detector is known as a crystal.

CRYSTAL CONTROL. Use of a quartz crystal to maintain operation of a radio station at its assigned frequency within the limits prescribed by law.

CRYSTAL DETECTOR. A detector utilizing a crystal such as silicon or galena in contact with a pointed wire

to rectify an incoming radio signal. Used in crystal receivers.

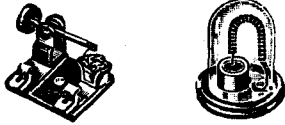

TYPES OF CRYSTAL DETECTORS

CRYSTAL FILTER. A highly selective tuning circuits employing a quartz crystal, sometimes used in the i.f. amplifier of a communications receiver to improve selectivity so as to permit reception of a desired station even when there is strong interference from other stations on nearby channels.

CRYSTAL PICK-UP. A type of phonograph pick-up in which the needle movements bend or twist a Rochelle salt crystal element and cause the crystal element to generate an audio frequency voltage corresponding to the recorded sound waves.

CRYSTAL SET.

A radio receiver which uses a crystal detector for signal rectification, and has no vacuum tubes.

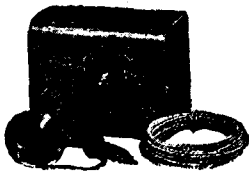

CURRENT. The movement of electrons through a conductor. Current is measured in amperes, in milliamperes and in micro-amperes.

CURRENT. Flow of electricity in conductors. The unit of current measurement is the ampere. Current is movement of free electrons along a conductor.

CUTOUT BOX. A surface-mounted covered enclosure for cutouts.

CUTTING HEAD. That part of a sound recorder which cuts or embosses on a disc, the irregular grooves corresponding to the wave form of the sounds being recorded.

C.W. Continuous wave.

CYCLE. One complete reversal of an alternating current, including a rise to a maximum in one direction, a return to zero, a rise to a maximum in the other direction, and another return to zero. The number of cycles occurring in one second is the frequency of an alternating current. The word cycle is commonly interpreted to mean cycles per second, in which case it is a measure of frequency.

CYCLE. In an alternating current, the increases, decreases and reversals of direction which carry the current through one complete set of changes or one complete set of motions in opposite directions. A cycle consists of two alternations.

D

DB. Decibel.

D.C. Direct current.

D.C.C. Double cotton covered insulation on wires.

D.C. RECEIVER. A receiver designed to operate from a d.c. power line, such as from the 110-volt d.c. lines still being used in older sections of some cities.

D'ARSONVAL METER MOVEMENT.

The commonest movement employed in precision direct current measuring instruments. It consists essentially of a small coil of wire supported on jeweled bearings between the poles of a permanent magnet, with a spiral spring holding the coil and the attached indicating pointer at the zero position on the meter scale. When the current to be measured is sent through this coil, the magnetic fields of the coil and magnet interact to cause rotation of the coil and pointer.

DEAD END. The ends of circuit wires which are attached to supports but which are not connected to any load.

DEAD SPOT. A region in which signals from certain radio stations are poorly received.

DECIBEL. A unit used for comparing the power level of a signal to a fixed reference level of power. Also a measure of power, current or voltage gain.

DELAYED A.V.C. An automatic volume control circuit which does not begin to act until signals reach a certain strength. It permits reception of weak signals even though they are fading at times, whereas normal a.v.c. tends to make weak signals weaker.

DEFINITION. In television, the clearness with which all detail in the scene are being reproduced.

DEGENERATION. A type of feedback which reduces signal strength. Degeneration is the opposite of regeneration.

DEMAND FACTOR. The ratio of the maximum demand of a system, or part of a system, to the total connected load of the system or the part of the system considered. The maximum watts actually used at any time, divided by the total wattage of all equipment connected to the system.

DEMODULATION. The process of rectifying or detecting a modulated radio signal in order to remove the carrier and obtain the desired audio or picture signal.

DETECTOR. That stage in a receiver at which demodulation takes place. In the detector stage of a t.r.f. receiver, the r.f. signals are separated from the desired audio signal. In the second detector of a superheterodyne receiver, the i.f. signals are separated from the desired audio signal.

DIAL. Any means for indicating the value to which a control knob has been adjusted. Tuning dials of broadcast band receivers indicate the frequency to which the receiver is tuned, either in kilocycles directly or in kilocycle values having one zero removed; sometimes the wavelength in meters will also be indicated.

DIAL CABLE. The braided cord or flexible wire cable used to make a tuning knob control the position of the pointer or dial which indicates the frequency to which a radio receiver is tuned.

DIAL LIGHT. The pilot lamp which illuminates the tuning dial of a radio receiver.

DIAPHRAGM. A thin, flexible metallic or non-metallic sheet which vibrates when struck by sound waves, as in a microphone, or which produces sound

waves when moved back and forth at an audio rate, as in a headphone or loudspeaker.

DIELECTRIC. Any insulating material, but usually one having such exceedingly high electrical resistance as to effectively prevent flow of any current through it. A dielectric used between conductive plates in a condenser receives and retains the electric charge of the condenser. Air, mica, glass and paper are common dielectrics.

DIELECTRIC CONSTANT. The dielectric constant of a material is the ratio of the capacitance of a condenser using that material as its dielectric to the capacitance of a condenser otherwise similar but having air or a vacuum for the dielectric. The increase of capacitance caused by using the material instead of air for the dielectric.

DIELECTRIC STRENGTH. The number of volts required to break down or puncture an insulating material, and thus to permit flow of current through the material.

DIODE. A vacuum tube having two electrodes, one being the cathode and the other the plate or anode. A diode allows electrons to pass in only one direction, from the cathode to the anode.

DIRECT COUPLING. The use of a conductor to connect two circuits together and provide a direct path for signal currents.

DIRECT CURRENT. An electric current that flows always in the same direction in its circuit. The current may be steady or of constant value, or it may vary in strength, or there may be intervals of no current, but so long as current that does flow always moves in the one direction it is a direct current.

DIRECTIONAL ANTENNA. Any antenna which picks up or radiates signals better in one direction.

DIRECTION FINDER. A special type of radio receiver employing a highly directional loop antenna so as to permit determining the direction from which radio waves are arriving.

DISCRIMINATOR. In an F.M. receiver, the section which converts frequency modulated signals into audio signals.

DISCRIMINATOR. In a frequency modulated radio receiver, the tube and circuit which change the frequency modulation into variations of voltage at audio frequency, serving the same purpose as the second detector in an amplitude modulated superheterodyne receiver.

DISTORTION. Improper reproduction of a sound or television radio program due to changes occurring in the wave form of the intelligence signal somewhere in the path it takes through the transmitting and receiving system or through an amplifier system.

DISTRIBUTED CAPACITY. Capacity distributed between conducting elements such as wires, as distinguished from capacity concentrated in a condenser. Usually used to specify the small capacity existing between the turns of wire in a coil.

DOUBLE-BUTTON CARBON MICROPHONE. A carbon microphone employing two buttons or containers

for carbon granules, one on each side of the diaphragm, so as to secure a push-pull action which gives increased signal output.

DOUBLE-POLE. Descriptive of a switch or other device connected in both sides of a circuit, or controlling both sides of the circuit at one time.

DOUBLE POLE SWITCH. A switch which simultaneously opens or closes two separate circuits or both sides of the same circuit.

DOUBLE THROW SWITCH. A switch which connects one circuit terminal to either of two other circuit terminals.

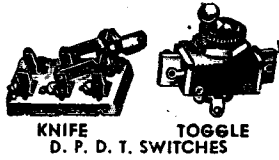

DOUBLE ANTENNA. An antenna system with an insulator inserted at its exact center, with one lead of a two-wire transmission line connected to each half of the antenna at this insulator.

D.P.D.T. Double pole, double throw.

D.P.S.T. Double pole, single throw.

DRAIN. A term used to indicate that current is being taken from a voltage source.

DRIVER. A stage of amplification used to feed or drive a final stage of amplification for the purpose of making the final stage operate at maximum efficiency.

DROP. The voltage drop developed across a resistor due to current flow through the resistor.

DRY CELL. A type of primary cell in which the electrolyte is in the form of a paste rather than a liquid. Dry cells are used extensively in radio batteries.

DRY CELL. A primary cell having a zinc outer can as its negative electrode, a central carbon rod as its positive electrode, and a liquid electrolyte of a small quantity of sal ammoniac and zinc chloride held in an absorbent lining and in a mass of powdered graphite and manganese dioxide, these latter two materials being the depolarizer. The cell is sealed. Its voltage is approximately 1.5.

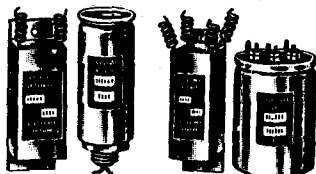

Dry Electrolytic Condensers

DRY ELECTROLYTIC CONDENSER. An electrolytic condenser in which the electrolyte is a paste rather than a liquid, to permit using the condenser in any position without danger of the electrolyte leaking out.

D.S.C. Double silk covered insulation on a wire.

DUMMY ANTENNA. A resistor or other device which duplicate the electrical characteristics of a transmitting antenna without radiating radio waves. Used for testing and adjusting transmitters.

DURALUMIN. An alloy of aluminum which is comparable in strength and hardness to soft steel. It contains 95.5 parts aluminum, 3 parts copper, 1 part manganese and .5 part magnesium.

DUSTPROOF. So constructed or protected that an accumulation of dust will not interfere with satisfactory operation.

DUST-TIGHT. So constructed that dust will not enter the enclosing case.

DX. A slang expression for distance, used chiefly in connection with reception of distant radio stations.

DYNAMIC LOUDSPEAKER. A loudspeaker in which the diaphragm or cone is attached to a small coil mounted so it can move within a constant magnetic field. Audio frequency currents flowing through this coil (called the voice coil) make it move in and out, thereby causing the diaphragm to reproduce sound waves. The magnetic field is produced by a permanent magnet in p.m. dynamic loudspeakers, and by an electromagnet in electrodynamic loudspeakers, and by an electromagnet in electrodynamic loudspeakers.

DYNAMOTOR. A rotating device acting both as motor and generator, used to change a d.c. voltage to an a.c. voltage or to a higher d.c. voltage. It is used chiefly for portable and mobile operation of radio transmitters and P.A. amplifiers from storage batteries.

E

E. Commonly used symbol for voltage.

EDDY CURRENTS. Circulating currents induced in conducting materials by varying magnetic fields. They are undesirable because they represent loss of energy and cause heating. Eddy currents are kept at a minimum by employing laminated construction for the iron cores of transformers, a.f.

EDISON BASE. The standard screw base used for ordinary electric light bulbs in this country.

EFFECTIVE CURRENT. That value of alternating current which will cause the same heating effect as a given value of direct current. For sine wave alternating currents, the effective value is approximately seven-tenths of the peak value.

EFFICIENCY. The ratio of energy output to energy input, usually expressed as a percentage. A perfect electrical device would have an efficiency of 100%.

ELECTRALLOY. A soft iron alloy used for radio chassis construction.

ELECTRICAL METALLIC TUBING. Thin-walled light-weight steel tubing used similarly to rigid conduit for carrying and protecting insulated electric wires.

ELECTRICAL TRANSCRIPTION. A disc recording of a complete program, as contrasted with a phonograph record which ordinarily contains only a single musical selection. Transcriptions are made to permit broadcasting of a particular program at any desired time by any number of stations.

ELECTRIC EYE. Popular expression for a cathode ray tuning indicator tube

used in modern radio receiving sets. Consists of a fluorescent screen with a dark sector which varies in direct proportion with the strength of the incoming signal. Also used in connection with photoelectric cells.

ELECTRIC FIELD. A region in space surrounding a charged object. Lines drawn to represent the direction in which the electric field will act on other charged objects are called electric lines of force. A moving electric field, such as that associated with electrons in motion or with a radio wave, is always accompanied by a moving magnetic field.

ELECTRICITY. A general term used when referring to the energy associated with electrons at rest or in motion.

ELECTRODE. An essential part inside a vacuum tube, such as the cathode, the various grids and the anode. Also, the plates of a primary cell, secondary cell or electrolytic condenser.

ELECTRODYNAMIC LOUD-SPEAKER. A dynamic loudspeaker in which the constant magnetic field is produced by an electromagnet. The coil of this electromagnet is known as the field coil.

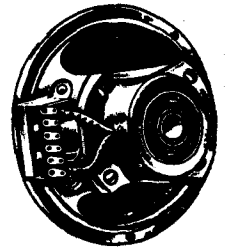

ELECTROLYTE. The liquid or chemical paste which is used between the electrodes of a dry cell storage battery or electrolytic condenser.

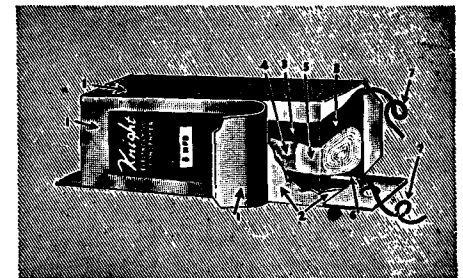

ELECTROLYTIC CONDENSER

1. Cardboard container
2. Wax-impregnated inner liner
3. Pure wax filler.
4. Etched aluminum foil.
5. Cellulose separator.
6. Terminal lead.
7. Insulated push-back leads.

ELECTROLYTIC CONDENSER. A fixed condenser in which the dielectric is a thin film of gas formed on the surface of one aluminum electrode by a liquid or paste electrolyte.

ELECTROMAGNET. A coil of wire, usually wound on an iron core, which produces a strong magnetic field when current is sent through the coil.

ELECTROMOTIVE FORCE. Voltage.

ELECTRON. A small active particle of negative electricity. Some electrons are closely associated with atoms of matter, while others, called free electrons, move readily between atoms under the influence of electric or magnetic fields. It is the movement of electrons through a conductor which constitute an electric current.

ELECTRON EMISSION. The ejection of electrons from the surface of a material into surrounding space due to

causes. In a thermionic vacuum tube, electron emission from the cathode is produced by heat from the filament.

ELECTRON GUN. In a cathode-ray tube or television picture tube, the cathode, the control grid and the first and second anodes; these being the parts that produce the electron beam and direct it against the fluorescent screen.

ELECTRONIC CONTROL. The control of a machine or device by apparatus employing electron tubes.

ELECTRONICS. A broad field of electricity covering work with all types of apparatus employing electron tubes for industrial applications. Radio and television are major branches of the electronic field.

ELECTRON TUBE. Any partly-evacuated, completely-evacuated or gas-filled tube used to control the flow of electrons in a circuit. Vacuum tubes, phototubes, mercury vapor rectifier tubes, cathode ray tubes are all electron tubes.

ELECTROPHORUS. An insulating disc and a metallic plate which, when placed together and the disc electrified by friction, produce opposite electric charges on the two elements when separated.

ELECTROSCOPE. An instrument for detecting the presence of an electric charge, or for determining the polarity of electric charges.

ELECTROSTATIC CAPACITY. The ability to receive and retain an electric charge. The capacity of a condenser, measured in microfarads or farads. Capacitance or permittance. The symbol is C.

ELEMENT. One of the ninety-three known basic forms of matter which make up the universe. The term is also used to refer to the important parts of a device; thus, the cathode, grid and plate would be called the elements of a triode vacuum tube.

E.M.F. Electromotive force or voltage.

ENAMELED WIRE. Wire coated with an insulating layer of baked enamel.

ENERGY. The ability to do work, or to cause movement against an opposing force when utilized in suitable equipment. Energy exists in bodies that are in motion, in bodies such as springs that are in a strained position, in electromotive force, in chemicals, and in heat. Energy existing in one form may be changed to energy existing in other forms; as when chemical energy in a battery changes to electromotive force.

ENVELOPE. The glass or metal housing of a radio tube.

EQUALIZING SIGNAL. The portion of a television signal that insures that the two fields making up one frame start at the correct positions on the picture area of the picture tube at the receiver.

ESCUTCHEON. The ornamental wood, metal or plastic framework for a radio dial, tuning indicator or other panel-mounted part in a radio receiver or amplifier.

ETHER. The medium which is supposed to fill all space, and through which radio, heat, and light waves are

supposed to travel. Its existence has not yet been definitely proved.

EXCITER. A small generator for supplying direct current to the field windings of an alternator. Sometimes refers to an oscillator.

EXPLOSION-PROOF. Enclosed in a case which is capable of withstanding an explosion of a specified gas or vapor within it, and of preventing the ignition by sparks, flashes or explosions of that gas or vapor surrounding the enclosure.

F

F. Frequency.

F. Fahrenheit. Scale of temperature.

FACSIMILE. A system of radio communication in which photographs, drawings, handwriting, and printed matter of any kind are transmitted to receivers which feed into facsimile recorders.

FACSIMILE RECORDER. An instrument which reproduces on paper the illustration, writing or printed matter being transmitted by a facsimile system.

FADING. An essentially regular rise and fall due to variations in transmission conditions along the path taken by the radio waves from the transmitting station to the receiver.

FAHRENSTOCK CLIP. A spring-type terminal to which a temporary connection can readily be made.

FAHRENHEIT. The temperature-measuring system generally used in the United States, in which 32 degrees is the temperature of melting ice and 212 is the temperature of boiling water at sea level.

FARAD. The basic unit of capacity, but too large for practical use. The microfarad, equal to one millionth of a farad, is a more practical unit for radio work. An even smaller unit, the micro-microfarad, is also used in radio; it is equal to one millionth of a microfarad.

F.C.C. Federal Communications Commission. A commission appointed by the President of the United States and given licensing and regulating authority on matters dealing with wire and radio communication in the United States and its possessions.

FEEDBACK. Transfer of energy from one point in an electrical system to a preceding point, such as from the output back to the input.

FEEDER. Any conductors of a wiring system between the service equipment, or the generator switchboard of an isolated plant, and the overcurrent devices that protect branch circuits.

FIDELITY. The faithfulness with which part or all of an electrical system delivers an exact reproduction of the input signal wave form.

FIELD. The effect produced in surrounding space by an electrically charged object, by electrons in motion, or by a magnet.

FIELD. 1. Magnetic or electromagnetic field; the space in which appear the magnetic lines of force around a magnet or an electromagnet. 2. Electrostatic field; the space between two opposite electric charges, in which ap-

pear electrostatic lines of force. 3. Television field; one travel of the scanning beam over the picture image area in the television camera. There are two fields per frame.

FIELD COIL. In an electrodynamic loudspeaker, the coil which produces the constant-strength magnetic field.

FIELD FREQUENCY. In television systems employing interlaced scanning, this term refers to the number of times per second the frame area is fractionally scanned.

FIELD MAGNET. The permanent magnet or electromagnet which supplies a magnetic field in a generator, motor or other electrical equipment.

FILAMENT. The resistance wire through which filament current is sent in a vacuum tube to produce the heat required for electron emission. When electron emission is from the surface of the filament wire itself, the filament is also serving as the cathode. When the filament merely supplies heat to a separate cathode electrode, we have a heater-type or indirectly-heated tube.

FILAMENT CIRCUIT. The complete circuit over which filament current flows from the A battery, filament winding or other filament voltage source to the filaments of radio tubes and pilot lamps.

FILAMENT CURRENT. The current supplied to the filament of a vacuum tube for heating purposes.

FILAMENT VOLTAGE. The voltage value which must be applied to the filament terminals of a vacuum tube in order to provide the rated value of filament current.

FILAMENT WINDING. A separate secondary winding provided on the power transformer of a radio receiver or other a.c.-operated apparatus for use as a filament voltage source.

FILTER. A resistor, coil, condenser or any combination of these parts which is used to block or attenuate alternating currents at certain frequencies while allowing essentially unimpeded flow of currents at other frequencies or of direct current. Thus, the filter in a radio power pack is a coil, condenser and resistor combination which receives a pulsating direct current having many a.c. components, but delivers an essentially pure and constant direct current.

FILTER CHOKE. A coil used in a filter system to pass low frequency currents or direct current while limiting or blocking the flow of higher-frequency alternating or pulsating currents.

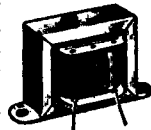

FILTER CONDENSER. A condenser used in a filter system to permit passage of higher-frequency currents while limiting or blocking the flow of lower-frequency currents and direct current.

FIRST AUDIO STAGE. The first stage in the audio amplifier of a radio receiver. Audio signals are fed into this stage by the detector of a t.r.f. receiver, and by the second detector of a superheterodyne receiver.

FIRST DETECTOR. That stage in a superheterodyne receiver in which the incoming modulated r.f. signal and the r.f. signal from the local oscillator are combined to produce the i.f. signal.

FITTING. A part such as a bushing or locknut which is intended to perform some mechanical function, rather than electrical, in a wiring system.

FIXED CONDENSER. A condenser having a definite capacity value which cannot be adjusted.

FIXED RESISTOR. A resistor having a definite ohmic value which cannot be adjusted.



FLEXIBLE METAL CONDUIT. A hollow tube formed by spirally wound metallic strips, within which are placed insulated electric wires for protection and support.

FLOUORESCENT LAMP. A form of lamp which emits visible light when fluorescent material (phosphors) on the inside of the lamp tube are struck by streams of electrons passing between electrodes in the ends of the tube.

FLOUORESCENT SCREEN. A coating of chemical material which glows when bombarded by electrons. In a cathode ray tube, the coating is on the inside surface of the evacuated glass envelope of the tube.

FLUX. The magnetic lines of force in a magnet or in a magnet and its magnetic field. The flux, in magnetism, is similar to the current in electric circuits, since both terms refer to a flow.

FLYBACK PERIOD. A period or interval during which the scanning beam in the television camera is extinguished or is blanked while the controls which move the beam return to the conditions at which the following trace is to be made over the picture image.

F.M. Frequency modulation. Also written as f-m or FM.

FOCUSING CONTROL. In a cathode ray oscilloscope or television system, the control which adjusts the size of the visible spot produced at the screen by the electron gun in a cathode ray tube.

FOUR-WAY SWITCH. A switch used in a circuit that permits a single lamp to be controlled from any of three or more positions. The switch has four terminals which alternately are joined together in different pairs.

FRAME. In television, one complete scanning of every part of the field of view being transmitted.

FRAME. One complete scanning of the image in the television camera tube. One frame consists of two fields.

FRAME FREQUENCY. In television, the number of times per second the frame area is completely scanned.

FRAMING CONTROL. In television, a general term applying to any of the control knobs used for adjusting the centering, width and height of the reproduced image.

FREE ELECTRONS. Those electrons which are free to move between the atoms of a material when acted upon by electric or magnetic forces.

FREQUENCY. The number of complete cycles per second which an electric current, a sound wave or a vibrating object undergoes. Frequency in cycles is equal to the velocity divided by the wavelength.

FREQUENCY CONVERTER. A circuit or device which changes the frequency of an alternating current. Thus, the oscillator and mixer-first detector stages make up the frequency converter of a superheterodyne receiver.

FREQUENCY DISTORTION. A type of distortion which occurs when a circuit or device amplifies or transmits unequally the different frequencies it is handling.

FREQUENCY MODULATION. A relatively new system of radio broadcasting perfected by Major E. H. Armstrong, in which the amount of deviation in frequency above and below the resting frequency is at each instant proportional to the amplitude of the sound wave being transmitted, and the number of complete deviations per second above and below the resting frequency is equal to the frequency of the sound wave being transmitted.

Advantages of this system include almost complete freedom from atmospheric and man-made interference, as well as little or no interference between stations, thereby permitting the transmission of a much greater volume range and a wider audio frequency range than is possible with amplitude modulation. One disadvantage is the necessity of employing ultra-high carrier frequencies, at which the range of a station is limited to approximately 100 miles.

FREQUENCY RESPONSE. A rating or graph which expresses the manner in which a circuit or device handles the different frequencies falling within its operating range. Thus, the frequency response of a loudspeaker may be specified as being essentially flat, or uniform between 100 and 6000 cycles.

FULL-WAVE RECTIFIER. A radio tube or other device which rectifies an alternating current in such a way that both halves of each input a.c. cycle appear in the pulsating rectified output. A full-wave rectifier tube contains two separate diode sections, one passing current during one alternation, and the other passing current during the opposite half cycle.

FUSE. A strip or wire of metal which, when it carries an electric current greater than the capacity or rating of the fuse, will become so heated by the excess of current as to melt or burn out. The fuse is connected in the circuit to be protected against overcurrent, and melts to open the circuit when overcurrent exists in the circuit. A fuse sometimes is called a cutout. Other overcurrent protective devices include automatic relays and circuit breakers.

G

GAIN. In an amplifier stage or system, the ratio of output voltage, current or power to input voltage, current or power. Usually expressed in decibels.

GALENO. Lead sulphide, a shiny bluish gray mineral often used as the crystal in a crystal detector.

GANG SWITCH. Two or more rotary switches mounted on the same shaft and operated by a single control.

GANG TUNING CONDENSER. Two or more variable tuning condensers

mounted on the same shaft and operated by a single control.

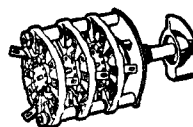

GANG SWITCH
(ROTARY)

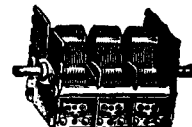

GANG TUNING
CONDENSER

GASEOUS TUBE. An electronic tube into which a small amount of gas or vapor is admitted after the tube has been evacuated. Ionization of the gas molecules during operation of the tube gives greatly increased current flow.

GAS-FILLED LAMP. An incandescent lamp whose bulb is filled with nitrogen and argon gases which permit operating the filament at higher temperatures than in vacuum lamps.

GENERATOR. A rotating machine which converts mechanical energy into electrical energy. Also, a radio device or circuit which develops an a.c. voltage at a desired frequency when energized with d.c. or low frequency a.c. power.

GETTER. An alkali metal introduced into a vacuum tube during manufacture and vaporized after the tube has been evacuated, to absorb any gases which may have been left by the vacuum pump. The silvery deposit on the inside of the glass envelope of a tube, usually near the tube base, is the result of getter vaporization.

GHOST IMAGE. In television, an undesired duplicate image appearing a fraction of an inch to one side of the desired image, due to reception of a reflected signal along with the signal coming directly from the television station. The remedy involves using a directional receiving antenna adjusted so it will receive signals coming over only one path.

GLASS-TYPE TUBE. A vacuum tube or gaseous tube having a glass envelope or housing.

GLOW LAMP. A gaseous tube having a glass envelope through which can be seen a glow due to ionization of the molecules of gas. Neon gas gives a red glow, mercury vapor gives blue, and argon gas gives a light purple glow. Also called glow tube.



GRAM. The unit of weight in the metric system. One pound is equal to 453 grams.

GRID. An electrode mounted between the cathode and the anode of a radio or electronic tube to control the flow of electrons from cathode to anode. The grid electrode is usually either a cylindrical-shaped wire screen or a spiral of wire through which electrons can readily move.

GRID BIAS. Another term for C bias, which is the voltage used to make the control grid of a radio tube negative with respect to the cathode.

GRIP CLIP. A spring clip used to make an easily removable connection to the cap terminal located at the top of some radio tubes.

GRID CONDENSER. A small fixed condenser inserted in the grid circuit of a vacuum tube.

GRID LEAK. A resistor of high ohmic value, used to connect the control grid to the cathode in a grid leak-condenser detector circuit.

GRID-LEAK-CONDENSER DETECTOR. A type of detection in which a.f. potentials developed across a grid resistor by the flow of grid current through that resistor result in plate current changes at the desired audio frequencies. This type of detector is identified by the presence of a grid leak and grid condenser in the grid circuit.

GRID RETURN. The lead or connection which provides a path for electrons from the grid circuit or C bias battery to the cathode.

GRILLE. An arrangement of wood or metal bars placed across the front of the loudspeaker in a radio receiver for protective purposes and to enhance the design of the cabinet.

GRILLE CLOTH. A loosely woven cloth stretched behind the loudspeaker grille of a radio receiver to keep dust and other foreign matter out of the loudspeaker diaphragm. Sound waves travel unimpeded through this cloth.

GROMMET. A special washer, made of rubber or other insulating material, used to prevent a wire from touching the sides of a chassis hole through which the wire is run.

GROUND CLAMP. A metal strap or clamp used for making a good electrical connection to a ground rod or grounded pipe. The clamp has a screw terminal or soldering lug to which the ground wire of a radio receiver can readily be attached.

GROUND WIRE. The wire used to connect the ground terminal of a radio receiver or transmitter to a ground clamp or other grounded object.

GROUND WAVES. Radio waves which travel along the surface of the earth instead of going up into the sky.

GROUNDING CONDUCTOR. A wire or other conductor used to connect electrical equipment or one of the conductors in a wiring system with ground or with a grounding electrode buried in the earth.

GUTTER. A trough or recess for wire leads and wire splices in a cabinet or box.

GUY WIRE. A wire used to brace the mast or tower of a transmitting or receiving antenna system.

H

HALF-WAVE RECTIFIER. A radio tube or other device which converts alternating current into pulsating direct current by allowing current to pass only during one half of each alternating current cycle. A half-wave rectifier tube contains only one diode section.

HARMONIC. A multiple of any particular frequency. Thus, the second harmonic of a fundamental frequency would be equal to two times that fundamental frequency.

HARMONIC DISTORTION. Another name for wave form distortion.

HARTLEY OSCILLATOR. A vacuum tube oscillator circuit identified by a tuned circuit which employs a tapped winding connected between the grid

and plate of the vacuum tube, with the tap going to the cathode.

HAZARDOUS LOCATIONS. Locations in which special types of electrical equipment and devices are required to insure safety. Places where flammable materials are stored other than in original containers, where dust may become combustible or explosive, where dust and dirt collect in such quantities as to cause overheating, and where combustible materials are handled, manufactured, stored or used.

HAZELTINE LICENSED. Radio apparatus which uses Hazeltine patents under a licensing agreement with the Hazeltine Corporation.

HEADPHONE. A small telephone receiver, held against an ear by a clamp passing over the head, used for private reception of radio programs or for reception of signals which are too weak to provide loudspeaker volume. Headphones are usually used in pairs, one for each ear, with the clamping strap holding them both in position.



HEATER. A filament used in a vacuum tube only for the purpose of supplying heat to an indirectly heated cathode.

HEAVISIDE LAYER. A layer of ionized gas which scientists believe exists in the region between 50 and 400 miles above the surface of the earth, and which reflects radio waves back to earth under certain conditions. Also called the Kennelly-Heaviside layer.

HELIX. A coil formed by a single-layer spiral winding, usually with no iron in the core space.

HENRY. The practical unit of inductance.

HIGH-FIDELITY RECEIVER. A receiver capable of reproducing audio frequencies in a range from 50 to about 8,000 cycles or wider without serious distortion. A receiver which approaches the goal wherein the reproduced program cannot be distinguished from the original studio program.

HIGH-FREQUENCY TRIMMER. In a superheterodyne receiver, the trimmer condenser which controls the calibration of a tuning circuit at the high-frequency end of a tuning range.

HOLD CONTROLS. In a television receiver, the two manually-adjusted controls which adjust the natural oscillating frequencies of the oscillators employed in the horizontal and vertical sweep circuits.

HOOK-UP. A diagram giving circuit connections for a radio receiver, amplifier or transmitter.

HORIZONTAL OSCILLATOR. In a television receiver, the oscillator that uses the horizontal synchronizing and blanking signals to produce voltages which, when amplified, operate the deflecting plates or coils in the picture tube.

HOT-CATHODE TUBE. A vacuum or gaseous tube in which the cathode is heated to provide electron emission.

HOT WIRE METER. A current-indicating meter whose pointer is allowed to move across the dial when a wire inside the meter is heated and expanded by the measured current flowing through this wire.

HOWL. An undesirable audio frequency oscillation occurring in a radio or amplifier system, due either to electrical or acoustic feedback.

HUM. A low and constant audio frequency, usually either 60 to 120 cycles, heard in the background of a received radio program. A defective filter condenser in an a.c. power pack is a common cause of hum in a radio receiver.

HYDROMETER. A weighted hollow bulb with an extended graduated stem which, when partially immersed in a liquid, sinks to a level such that the specific gravity of the liquid is indicated on the stem.

HYSTERESIS. In the iron or steel of a magnetic circuit energized by a coil winding, the lag of magnetic flux behind the rate at which current increases in the coil, and the lag in reduction of flux behind the rate at which coil current decreases. There is a similar effect or similar lag of electrostatic flux in a dielectric with changes of voltage which produce the flux.

I. Commonly used to designate current.

ICONOSCOPE. A form of cathode-ray tube used in the camera of a television transmitter. The tube contains a mosaic or an area covered with photosensitive globules on which the image is focused, also a conductive plate and a collector which receives electrons emitted by the sensitive globules.

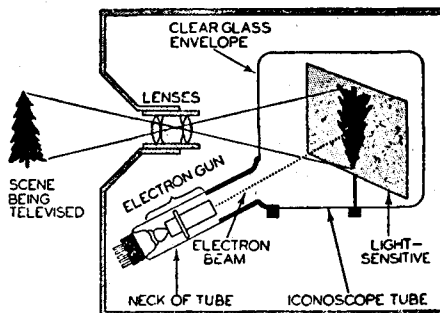

I.F. Intermediate frequency.

IMAGE. An interfering signal whose frequency is twice the I.F. frequency of receiver.

IMAGE DISSECTOR. A cathode ray television pickup tube. Construction and operating principles are different from those of the iconoscope, but serves essentially the same purpose of converting a scene into corresponding electrical impulses.

IMAGE RATIO. The ratio of the strength of a signal to its image. Used to indicate selectivity of a receiver.

IMAGE RECONSTRUCTOR. The cathode ray tube used in a television receiver to convert received signals to original picture.

IMPEDANCE. The total opposition which a radio part or circuit offers to the flow of alternating or pulsating direct current at a particular frequency. Impedance is a combination of resistance and reactance, and is measured in ohms.

IMPULSE. A momentary increase in the current or voltage in a circuit.

INCANDESCENT LAMP. An electric lamp in which light is produced by the white-hot temperature of the filament in which heat is produced by current flowing against the resistance of the filament.

INDOOR ANTENNA. A receiving antenna system located entirely inside a building, either under a rug, around the walls, or in the attic.

INDUCED VOLTAGE. A voltage produced in a circuit by changes in the number of magnetic lines of force which are linking or cutting through the conductors of the circuit.

INDUCTANCE. That property of a coil or other radio part which tends to prevent any change in current flow. Inductance is effective only when varying or alternating currents are present; it has no effect whatsoever upon the flow of direct current. Inductance is measured in henrys.

INDUCTION. Electromagnetic induction is the production of an emf or voltage in a conductor which moves through a magnetic field and cuts across the lines of force, or when the magnetic field is moved across the conductor. Magnetic induction is the production of magnetism in a piece of iron or steel by magnetic lines of force from another magnet.

INDUCTION MOTOR. An alternating-current motor in which energy from stationary windings is transferred to conductors on the revolving rotor by electromagnetic induction, and in which the rotor receives no current through any conductive connections such as brushes and a commutator or slip rings.

INDUCTIVE COUPLING. A form of coupling in which energy is transferred from a coil in one circuit to a coil in another circuit by induction. Magnetic lines of force produced by the flow of current through one coil cause an a.c. voltage to be induced in the other coil.

INDUCTIVE REACTANCE. Reactance due to the inductance of a coil or other part in an alternating current circuit. Inductive reactance is measured in ohms, and is equal to the inductance in henrys multiplied by the frequency in cycles, times the number 6.28; inductive reactance therefore increase with frequency.

INSTANTANEOUS VALUE. The voltage, current or other value at some instant of time in a circuit wherein the voltage or current is continually changing, as with alternating current.

INSTRUMENT TRANSFORMER. A current transformer, which see.

INSULATION. Any material which has a sufficiently high electrical resistance to permit its use for separating one electrical circuit, part or wire from others. Cotton, silk, baked enamel, mica, porcelain, rubber and bakelite are a few of the common insulating materials used in radio.

INSULATOR. A part made of insulation in a form suitable for supporting electrical conductors or for separating them electrically from other conductors.

INTELLIGENCE SIGNAL. Any signal which conveys information, such as voice, music, code, television pictures, facsimile photographs, diagrams, written and printed matter, etc.

INTERCOMMUNICATION SYSTEM. An amplifier system which provides two-way communication between two or more rooms in a building. Each station in the system contains a microphone and loud-speaker, usually combined as a single dynamic unit; a headphone or telephone receiver is sometimes provided also for private reception of messages. The stations may be connected to each other by wire cables, or may receive and transmit messages through the electric wiring system in the building.

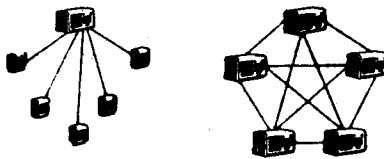

INTERCOMMUNICATION SYSTEMS

INTER-ELECTRODE CAPACITY. The capacity which exists between two electrodes in a vacuum tube. Although this is usually a very low value, it becomes extremely important when tubes are operated in ultra-high frequency circuits.

INTERFERENCE. Noises or undesired radio programs which interfere with reception of a desired radio program.

INTERFERENCE FILTER. A device used between source of interference and a radio to attenuate or eliminate noise. Generally consists of a capacity and inductance which offers a high impedance to noise impulses.

INTERLACED SCANNING. In television, a type of scanning to which every other line of the image is scanned during one downward travel of the scanning beam, and the remaining lines are scanned during the next downward travel of the scanning beam.

INTERMEDIATE FREQUENCY. In a superheterodyne receiver, the frequency to which all incoming carrier signals are converted before being fed into the intermediate frequency amplifier.

INTERMEDIATE FREQUENCY AMPLIFIER. That section of a superheterodyne receiver which is designed to amplify signals with high efficiency at a predetermined frequency called the intermediate frequency of the receiver.

INTERMEDIATE FREQUENCY TRANSFORMER. A transformer used at the input and output of each i.f. amplifier stage in a superheterodyne receiver for coupling purposes and for providing selectivity.



INTERMEDIATE LAMP-HOLDER. A lampholder having a nominal screw diameter of 21/32 inch.

INTERMITTENT RECEPTION. A type of radio receiver trouble in which the receiver performs normally for a time, then becomes dead or distorts the programs, with the process repeating itself.

INTERNAL RESISTANCE. The resistance of conductors inside some electrical equipment or device; the resistance of the device or equipment measured between its terminal connections. The resistance of conductors through which currents flow inside a battery, generator or motor.

INTERNATIONAL MORSE CODE. The code used universally for radio

telegraphy, and also used for wire telegraphy in some European countries. It is also known as the Continental Code.

INVERSE FEEDBACK. Intentional negative feedback or degeneration, introduced in an amplifier or single vacuum tube stage for the purpose of reducing distortion, thereby permitting greater power output.

INVERTED L ANTENNA. The conventional antenna used for broadcast reception, having a long horizontal portion suspended between insulators, with the single wire lead-in connected to one end of the horizontal portion.

ION. An atom or molecule which has fewer or more electrons than normal. A positive ion is one which has lost electrons, and a negative ion is one which has acquired more electrons than normal.

IONIZATION. An action whereby atoms or molecules of gas in an electronic tube are converted into electrically charged ions which are attracted by charged electrodes. Ionization makes a gaseous tube more conductive than an equivalent vacuum tube.

IR DROP. A technical expression sometimes used to designate the voltage drop developed across a resistance by the flow of current through the resistance.

IRON-CORE COIL. A coil having iron inside its windings. The iron is usually in the form of laminations, but it may also be pulverized iron mixed with a binding material.

IRON-CORE TRANSFORMER. A transformer in which iron makes up part or all of the path for magnetic lines of force traveling through the transformer windings.

ISOLANTITE. A high-quality insulating material used in the construction and mounting of radio parts, particularly those employed in ultra-high frequency circuits.

ISOLATED PLANT. A private electrical installation deriving energy from its own generator driven by a prime mover such as a gas engine.

ISOLATING SWITCH. A switch intended only for disconnecting its circuit from a source of power after the circuit has been opened and current stopped by some other means.

J

JACK. A plug-in type spring terminal widely used in radio apparatus for temporary connections. A connection is made to a jack simply by plugging into it a probe or plug attached to a flexible insulated wire or cable. Some jacks have extra contacts which are opened or closed when the probe is inserted, thereby giving automatic switching action.

JAMMING. Intentional transmitting of radio waves in such a way as to interfere with reception of signals from another station.

JOULE. A unit of electrical energy or of work, equal to the energy transferred by a power rate of one watt continuing for one second. The work done by sending one ampere of elec-

tricity through a resistance of one ohm for one second.

JUMPER. A wire used to connect two points together temporarily.

K

K. Letter used to designate the cathode of a radio tube.

KC. Kilocycle.

KENNELLY-HEAVISIDE LAYER. A layer of ionized gas supposed to exist in the region between 50 and 400 miles above the surface of the earth. It reflects radio waves back to earth under certain conditions, making possible long-distance reception.

KEY. A lever-type switch designed for rapid opening and closing of a circuit during transmission of code signals.



KILOCYCLE. One thousand cycles but commonly interpreted as 1,000 cycles per second.

KILOWATT. One thousand watts.

KINESCOPE. A cathode ray tube developed by the Radio Corporation of America and used in television receivers for the purpose of reproducing on a screen the scene originally televised.

KIRCHOFF'S CURRENT LAW. A fundamental electrical law which states that the sum of all the currents flowing to a point in a circuit must be equal to the sum of all the currents flowing away from that point.

KIRCHOFF'S VOLTAGE LAW. A fundamental electrical law which states that the sum of all the voltage sources acting in a complete circuit must be equal to the sum of all the voltage drops in that same circuit.

KNIFE SWITCH. A switch in which one or more flat metal blades, each pivoted at one end, serve as the moving parts. The blades are usually of copper; when the switch is closed, they make contact with flat gripping spring clips and complete the circuit.

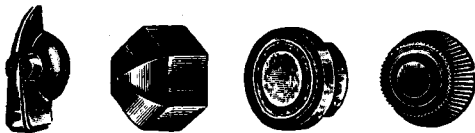

TYPES OF RADIO KNOBS

KNOB. A radio part, usually round but sometimes having a pointer or other position-indicating means, which is attached to the end of a control shaft to make it easier to rotate the shaft with the fingers.

KW. Kilowatt.

L

L. The letter commonly used on circuit diagrams and in formulas to designate an inductance or coil.

LAMINATED. A type of construction widely used for the cores of iron core transformers, choke coils, electromagnets, motors and generators. It involves building up the desired shape of core with thin strips of a magnetic

material such as soft iron or silicon steel.

LAMPHOLDER. A screw shell device for receiving the screw base of an incandescent lamp bulb or other part with a similar screw base, and for making electrical connections to the part thus held. Often called a lamp socket.

LAPEL MICROPHONE. A small microphone which can be attached to a lapel or pocket by means of a clip.

LAYOUT. A diagram indicating the placement of parts on a panel or chassis.

LEAD-ACID BATTERY. A storage battery in which the plates for the cells have active materials of sponge lead and lead peroxide, and in which the electrolyte liquid is a mixture of sulphuric acid and water. The most common type of storage battery.

LEAD-IN. A wire which serves to connect the outdoor signal pickup portion of an antenna system with the antenna terminal of a radio receiver.

LEAD-IN INSULATOR. A porcelain tube inserted in a hole drilled through an outer wall or window frame of a house. The lead-in wire of the antenna is run through this tube.

LEAKAGE. Undesirable flow of current through or over the surface of an insulating material. This term is also used to describe magnetic flux which wanders off into space without doing useful work.

LEAKAGE FLUX. That portion of the total magnetic flux which does not link all of the turns of wire in a coil or transformer and is consequently wasted.

LEAKAGE RESISTANCE. The resistance of a path taken by leakage currents. Thus, the leakage resistance of a condenser is the normally high resistance which it offers to the flow of the direct current.

LEYDEN JAR. A form of condenser consisting of a glass jar which acts as the dielectric, coated inside and outside with tin foil which acts as the conductive plates.

LIGHTING OUTLET. In a building wiring system an outlet intended for direct connection of a lampholder, a lighting fixture, or a cord that carries a lampholder.

LIGHTNING ARRESTER. A protective device used to sidetrack directly to ground a discharge of lightning which strikes a radio receiving or transmitting antenna.



LIMITER. In a frequency modulation radio receiver, a tube circuit which eliminates any amplitude modulation which may have affected the carrier wave and leaves only the frequency modulation.

LINE CORD. A two-wire cable terminating in a two-prong plug, used to connect a radio receiver to an a.c. or d.c. wall outlet. Sometimes this cord also includes a resistance wire used for the purpose of reducing the line voltage to the value required by the series-connected filaments of the tubes.

LINE FILTER. A device inserted between the line cord plug of a radio receiver and the power line to block noise signals which might otherwise enter the receiver from the power line. It contains one or more choke coils and condensers.



LINE OF FORCE. A path through space between magnetic poles or electrostatic poles, along which acts the magnetic force or electrostatic force as shown by lines drawn between the poles on a sketch.

LINE VOLTAGE. The voltage existing at a wall outlet or other terminals of a power line system. In the United States, the line voltage is usually between 115 and 120 volts, but may vary at times as much as five volts above and below these limits.

LOAD. Lamps, motors, heaters, or any other energy-consuming or power-consuming equipment connected to a battery, generator or a circuit supplying power and energy. The load might be measured in watts, watt-hours, ohms of resistance, amperes, volts, or any other unit which would indicate the size or magnitude of the load.

LOG. A list of radio stations. A record of stations with which a radio transmitter has been in communication; amateur radio operators are required by law to keep this log. A detailed record describing the program being broadcast each minute of the operating day by a broadcast station. A record of the meter readings which are required by law to be taken at regular intervals in a broadcast transmitter and in certain other types of transmitters.

LOGGING. Making a record of the exact dial setting at which a radio station is received, or making a written record of any other essential data in connection with radio equipment.

LOKTAI TUBE. A small-size glass radio tube having a special base, construction which locks the tube firmly in the corresponding special 8-prong loktai socket. Loktai tubes are used chiefly in midget a.c.-d.c. receivers and in auto radios.

LONG WAVES. Wave lengths longer than the longest broadcast band wave length of 545 meters. Long waves correspond to frequencies between about 20 kilocycles and 550 kilocycles.

LOOP ANTENNA. An antenna consisting of one or more complete turns of wire. It may be built into a radio receiver cabinet or separately mounted, and is usually tuned to resonance by a variable condenser. Loop antennas are used extensively in radio direction-finding apparatus.

LOSSES. Energy which is dissipated before it accomplishes useful work.

LOUDSPEAKER. A device for converting audio frequency signals into sound waves.

LOUVER. A type of loudspeaker grille construction in which sloping slats or equivalent parts of a molded plastic cabinet hide the loudspeaker yet allow sound waves to emerge unhindered. Also spelled louvre.

LOW-FREQUENCY PADDER. In a superheterodyne receiver, a semi-adjustable condenser which is placed in series with the oscillator tuning circuit.

to control the calibration of the circuit at the low-frequency end of the tuning range.

LOW-LOSS CONSTRUCTION. A type of radio part construction involving the use of insulating materials which maintain their insulating characteristics at high radio frequencies.

LUG. A small strip of metal placed on a terminal screw or riveted to an insulating material to provide a convenient means for making a soldered wire connection.

M

M. A letter sometimes used to indicate that a particular resistance value is to be multiplied by 1,000. Thus, 50M would mean 50,000 ohms.

MA. Milliampere.

MAGNET. A piece of iron or steel which has the property of attracting other pieces of magnetic material such as iron, and has the property of attracting or repelling other magnets.

MAGNET WIRE. Insulated copper wire in sizes commonly used for winding coils used in electro-magnetic devices such as transformers, choke coils and relays.

MAGNETIC CIRCUIT. A complete path for magnetic lines of force. It always includes the permanent magnet or electromagnet which is producing the magnetic lines of force.

MAGNETIC FIELD. A region in space surrounding a magnet or a conductor through which current is flowing.

MAGNETIC INDUCTION. The magnetizing of iron or steel by the magnetic field of a magnet which is near to or in contact with the magnetized metal.

MAGNETIC LINES OF FORCE. Imaginary lines used for convenience to designate the directions in which magnetic forces are acting throughout the magnetic field associated with a permanent magnet, electromagnet or current-carrying conductor.

MAGNETIC LOUD-SPEAKER. A loud-speaker consisting essentially of a permanent magnet, a pivoted armature which is mechanically connected to the diaphragm or cone, and a coil which is connected to the output stage of a radio receiver or other apparatus.

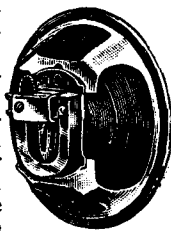

Interaction between the permanent magnetic field and that developed in the armature by the coil results in movement of the armature and production of sound waves by the diaphragm.

MAGNETIC PICK-UP. A phonograph pick-up consisting of a permanent magnet, one or two coils, an iron armature and a core structure so arranged that movement of the phonograph needle in the record groove varies the amount of magnetic flux passing through the coils, thereby inducing audio frequency voltages in the coils.

MAGNETIC FLUX. Total number of magnetic lines of force acting in a magnetic circuit.

MAGNETIC POLARITY. Identification of magnetic poles according to the

direction of lines of force; the north pole being the one at which lines issue from the magnet, and the south pole the one at which they re-enter the magnet.

MAN-MADE STATIC. High-frequency noise signals which are produced by sparking in electrical apparatus or power lines and picked up by radio receivers, with the result that buzzing and crashing sounds are heard along with a desired radio program.

MANUAL TUNING. Tuning a radio receiver to a desired station by rotating the tuning control knob by hand.

MASTER SERVICE. Service conductors and equipment for a group of buildings under one management.

MATCHING. Connecting two circuits or parts together with a coupling device in such a way that the impedance of either circuit will be equal to the impedance existing between the coupling terminals to which that circuit is connected.

MAXIMUM UNDISTORTED OUTPUT. The maximum audio power output which a radio receiver or audio amplifier will deliver without having more than 10% total harmonic distortion. Tests have shown that this amount of distortion is not ordinarily noticeable or objectionable.

MAXIMUM VALUE. The greatest value reached by an alternating voltage or current during any instant in the cycle.

MAYDAY. The international distress call for radiotelephone communication. It is derived from the French pronunciation of "M'aidez," meaning "Help me."

MC. Megacycle.

MEDIUM LAMPHOLDER. A lampholder having a nominal screw diameter of one inch.

MEG. Megohm.

MEGACYCLE. One million cycles per second.

MEGOHM. A resistance of one million ohms.

MERCURY. A heavy, silvery-colored metal which is liquid at ordinary room temperatures. When heated, it gives off a vapor which is highly conductive when ionized.

MERCURY VAPOR LAMP. A lamp in which a small quantity of mercury is vaporized by the heat of an electric discharge through argon gas, after which flow of current through the mercury vapor produces light.

MERCURY VAPOR RECTIFIER TUBE. A rectifier tube containing a small amount of mercury. When the filament or heater-type cathode is heated, mercury vapor is produced, and the resulting ionization of the mercury vapor molecules gives a much higher plate current than would be obtained in an equivalent vacuum type rectifier tube.

METALLIZED RESISTOR. A resistor made by depositing a thin film of high-resistance metal on the surface of a tube or rod made of glass or other insulating material. Leads are attached to opposite ends of the unit.



METAL-TYPE TUBE. A vacuum or gaseous tube having a metal envelope or housing, with electrode connections being made through glass beads fused into the metal envelope. Usually called all-metal tube.

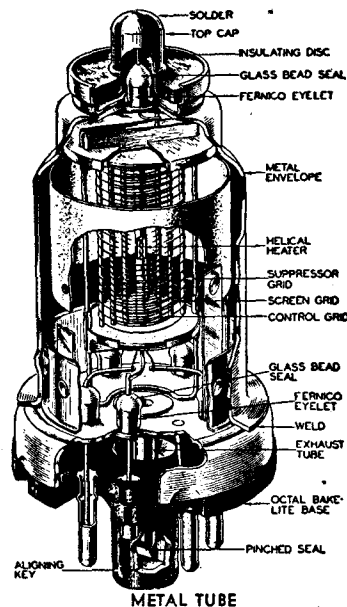

METAL TUBE
Courtesy R.C.A. Mfg. Co., Inc.

METER. The unit of length in the metric system; one meter is equal to 3.28 feet. An instrument used for making electrical measurements. A voltmeter measures voltage; an ammeter or milliammeter measures currents; a wattmeter measures power; an ohmmeter measures resistance.

MFD. Microfarad.

MH. Millihenry.

MICA. A transparent flaky mineral which splits readily into thin sheets and has excellent insulating and heat-resisting qualities. It is used extensively to separate the plates of condensers, to insulate electrode elements of vacuum tubes, and for many other insulating purposes in radio apparatus.

MICA CONDENSER. A condenser which employs sheets of mica as the dielectric material which insulates adjacent plates from each other.

MICRO. A prefix meaning one millionth.

MICROAMPERE. One millionth of an ampere.

MICROFARAD. A unit of capacity equal to one millionth of a farad. The microfarad is the capacity unit most commonly used in radio work. It is abbreviated as mfd.

MICRO-MICROFARAD. A unit of capacity equal to one millionth of a microfarad, and abbreviated as mmfd.

MICROPHONE. A device which converts sound waves into corresponding audio frequency electrical energy. It contains some form of flexible diaphragm which moves in accordance with sound wave variations. This movement, in turn, generates a minute voltage which is fed to the input of an amplifier where it is amplified many times. There are several types of microphones available, but they all operate on the above principle. **Carbon Microphone.** A microphone in which loosely packed carbon granules com-

plete the electrical circuit between two terminals. The resistance of this circuit varies in accordance with variations in the pressure exerted on the granules by the sound-actuated diaphragm. In a single-button carbon microphone, the granules are on only one side of the diaphragm. In a double-button carbon microphone the granules are on both sides of the diaphragm, giving a push-pull action which greatly increases the resistance change produced by a given diaphragm movement. **Condenser Microphone.** A microphone in which the diaphragm serves as one plate of a condenser. Sound waves move the diaphragm in and out, causing the capacity of the microphone and the current through it to vary in accordance with the sound waves. **Contact Microphone.** A microphone designed to pick up mechanical vibrations directly and convert them into electrical impulses. It is used chiefly with string, wind, and percussion musical instruments, and is simply strapped or clamped to the housing of the instrument. **Crystal Microphone.** A microphone depending upon the piezoelectric effect, or voltage produced in Rochelle salt crystals when subjected to mechanical stress such as that caused by sound waves. Two types are in use today, the sound-cell type and the diaphragm type. **Dynamic Microphone.** A microphone in which the diaphragm moves a voice coil back and forth in a constant magnetic field, causing audio currents to be induced in the coil. A small dynamic loudspeaker is often made to serve also as a dynamic microphone, particularly in two-way intercommunication systems. **Velocity or Ribbon Microphone.** A microphone in which a thin, light-weight ribbon of duralumin alloy serves as the diaphragm. This ribbon is mounted in a powerful fixed magnetic field. Audio frequency voltages are induced in the ribbon when it is moved back and forth through the magnetic field by sound waves.

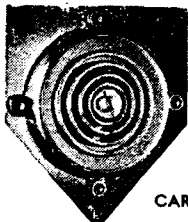

CARBON

CRYSTAL

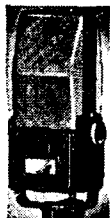

VELOCITY

DYNAMIC



crophone stand or in the microphone housing itself.

MICROPHONE BUTTON. A button-shaped container filled with carbon particles. When attached to the diaphragm of a microphone, the resistance between the terminals of the button varies in accordance with movements of the diaphragm.

MICROPHONE STAND. A table or floor-type stand used to support a microphone in a desired position.

MICROPHONE TRANSFORMER. The iron-core a.f. transformer which couples the microphone to a microphone amplifier, to a transmission line, or to the input circuit of the main audio amplifier.

MICROPHONIC. A condition in which mechanical movement of some radio part other than a microphone causes corresponding variations in circuit current. A radio tube is microphonic if a pinging sound is heard in the loudspeaker when the side of the tube is tapped with a finger; the tapping is then setting the internal elements into vibration. If sound waves from the loudspeaker are producing this vibration of tube elements, the sound will be sustained as a howl.

MIKE. A microphone.

MILLI. A prefix meaning one thousandth.

MILLIAMMETER. A measuring instrument which measures current flow in milliamperes.

MILLIAMPERE. An electric current of 1/1000 of an ampere.

MILLIHENRY. A unit of inductance equal to one thousandth of a henry.

MILLIMETER. A metric unit of length equal to one thousandth of a meter. One millimeter is approximately equal to one twenty-fifth of an inch.

MILLIVOLT. A unit of voltage equal to one thousandth of a volt.

MIXER. A control which permits combining the output signals of two or more microphones or other a.f. signal sources in any desired proportion before these signals are fed to the input of the main a.f. amplifier. Also, the stage in a superheterodyne receiver in which the incoming modulated r.f. signals are mixed with the local oscillator signals to produce the i.f. signal.

MM. Millimeter.

MOBILE STATION. A radio station operated in a movable location such as on an automobile, fire truck, railway train, ship or airplane.

MODULATED AMPLIFIER. The r.f. stage in a transmitter at which the intelligence signal is made to modulate the r.f. carrier signal.

MODULATED WAVE. A radio wave which varies either in frequency (frequency modulation) or in amplitude (amplitude modulation) in accordance with the wave form of the intelligence signal being transmitted.

MODULATION. The process of varying the frequency or the amplitude of an r.f. carrier signal in accordance with the wave form of the intelligence signal being transmitted.

MODULATOR. The final audio stage in a radio transmitter. It feeds the

intelligence signal into the modulated amplifier stage, where the signal is made to modulate the r.f. carrier signal.

MOGUL LAMPHOLDER. A lampholder having a nominal screw diameter of 1½ inches.

MOLECULE. The group of atoms which constitutes the smallest particle in which a compound or material can exist separately.

MONKEY CHATTER. Garbled speech or music heard along with a desired program. This type of interference occurs when the side frequencies of an adjacent-channel station beat with the desired station signal.

MONOSCOPE. A special type of cathode ray tube which produces television picture signals corresponding to the design or picture which has been printed on its screen. This tube is used in television picture signal generators to provide a satisfactory signal source for television receiver test purposes during those times when no television station is on the air.

MORSE CODE. A system of dot and dash signals used in the transmission of messages by radio or wire telegraphy. The International Morse Code (also called the Continental Code) is used universally for radio telegraphy, while the American Morse Code is used only for wire telegraphy.

MOSAIC. The photosensitive globules on their insulating mounting in the tube or Iconoscope of the television camera. The camera lens system focuses the image on the area of the mosaic.

MOTOR. A machine which converts electrical energy into mechanical energy.

MOTORBOATING. Regeneration occurring at audio frequencies in a radio receiver or audio amplifier, resulting in put-put-put sounds resembling those made by a motorboat.

MOTOR-CIRCUIT SWITCH. A switch that will open the maximum operating overland current of a motor, the switch being rated in horsepower which is the same as that of the motor.

MOTOR-GENERATOR. An electric motor directly connected to one or more generators for the purpose of converting a power line voltage to other desired voltages or frequencies.

MOTOR STARTER. A hand-operated or magnetically operated contactor or heavy-duty switching device for opening and closing the circuit feeding a motor or motors as the motors are stopped and started.

MOVING COIL METER. A current-actuated electric meter consisting of a permanent magnet between the poles of which is suspended a wire coil through which flows all or part of the current to be measured. The coil is mounted between end bearings and to it is attached the indicating pointer. The coil and pointer are moved by reaction between the magnetic fields of the permanent magnet and of the current-carrying coil.

MU. Amplification factor.

MULTI-

METER. A test instrument having provisions for measuring voltages and currents, as well as resistance. It usually consists of one or sometimes two meters provided with the necessary number of scales, and a range-selecting switch which places a meter in the correct circuit for a particular measurement. Also known as a multitester, multiple-purpose tester or voltohm-milliammeter.

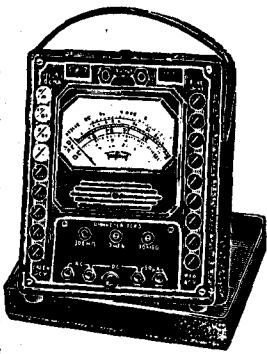

MULTIPLE CONNECTION. Same as parallel connection, which see.

MULTIPLIER. A resistor used in series with a voltmeter to increase the range of the meter.

MULTIPOLAR. Having more than one magnetic pole. Usually refers to an electric machine having more than two poles, the two-pole types being called bipolar or two-pole.

MUTUAL INDUCTION. Production of a varying or alternating emf in one circuit by movement across its conductors of field lines arising in another nearby circuit in which the current is varying.

N

NATURAL MAGNET. A lodestone, which see.

NEEDLE. That part of a phonograph pick-up which converts the variations in the record grooves into mechanical movements which are in turn converted into audio frequency signals by the pick-up element. The needle must be carefully shaped to follow faithfully the high-frequency variations in the grooves without causing excessive record wear.

NEGATIVE. Referring to a potential less than another potential, or to a potential less than that of the earth. A point toward which current flows in parts of a circuit external to the source.

NEGATIVE BIAS. The use of a voltage which makes the control grid of a radio tube negative with respect to the cathode.

NEGATIVE CHARGE. The electrical condition of a body on which are more than the normal quantities of negative electrons, so that the body has more negative electricity than has an uncharged or neutral body.

NEGATIVE FEEDBACK. Degeneration, causing a reduction in signal strength.

NEGATIVE MODULATION. In television, a method of transmission in which a decrease in scene illumination causes an increase in the radiated power of the transmitter.

NEON. A pure gas sometimes used in electronic tubes. It produces a characteristic red glow when ionized.

NEON GLOW LAMP. A neon-filled gaseous tube having a glass envelope through which can be seen the characteristic red glow of neon when ionization occurs during operation of the tube.

NETWORK. An electric circuit in which the parts cannot be classified as connected in series, in parallel, or in series-parallel, but in which the connections are of some special nature suited to the purpose for which the circuit is to be used.

NEUTRAL. Having electric or electrostatic potential intermediate between the potentials of other associated parts in a circuit; positive with reference to some parts while negative with reference to others. Sometimes refers to zero potential, neither positive or negative.

NEUTRALIZATION. A term used in radio to describe any process which balances out or prevents an undesirable effect such as oscillation.

NEUTRALIZING TOOL. A small screwdriver or socket wrench, constructed partly or entirely from non-metallic materials, and used for making neutralizing or aligning adjustments in radio receivers. It eliminates the body capacity effects which would affect the accuracy of the adjustments if an ordinary metal wrench or screwdriver were used.

NICHROME. An alloy of nickel, iron and chromium which has a high resistance per unit volume and is capable of withstanding high temperatures. It is used extensively in the construction of wire-wound resistors, as well as in the heating elements of soldering irons and other electrical heating appliances.

NOISE. In radio, a term used chiefly in connection with interfering sounds heard along with desired programs.

NOISE FILTER. A device which is inserted between a wall outlet and the power cord plug of a radio receiver to block noise interference which otherwise might enter the receiver.

NOISE LIMITER. A special radio circuit which limits the effects of interfering noises by cutting off all noise peaks which are stronger than the highest signal peak being received.

NOISE SILENCER.

A special vacuum tube circuit which can be introduced into superheterodyne receivers to reduce the effects of static and man-made interference noises. Its chief value is in short wave communication receivers.

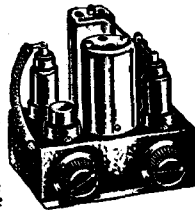

NOISE-REDUCING ANTENNA SYSTEM. An antenna system in which the only part capable of picking up signals is the antenna proper, this being erected high enough to be out of the noise-interference zone. The lead-in is a special shielded cable or twisted two-wire line which can pass through the interference zone without picking up noise signals.

NON-CONDUCTOR. Any material which offers very high opposition to the flow of electricity. An insulating material.

NON-MAGNETIC. Materials such as glass, wood, copper, brass and paper which are not affected by magnetic fields.

NON-METALLIC SHEATHED CABLE. Wire or cable enclosed within and protected by a covering of insulating compounds and fabric braids in layers providing fair mechanical strength. Used for some building wiring where this cable is permitted.



OBSOLESCENCE-FREE. Not liable to become out of date because of new developments or new inventions. A term applied particularly to tube testers and other test instruments.

OCTAL BASE. A type of tube socket base having eight equally-spaced prongs and a central aligning key. When some of the prongs are not needed, they are omitted without changing the positions of the remaining prongs.

OCTAL GLASS-TYPE TUBE. A glass tube having an octal base.

OHM. The unit of electrical resistance. The resistance of a device is one ohm when a d.c. voltage of one volt will send a current of one ampere through that device. The Greek letter omega (ω or Ω) is commonly used to represent ohm.

OHMIC DROP. Potential difference due to flow of direct current through resistance.

OHMIC VALUE. The resistance in ohms which a part or circuit offers to the flow of direct current.

OHMMETER. A test instrument which measures and indicates directly the resistance of a part or the resistance between any two points in a circuit. It consists essentially of a milliammeter in series with a suitable d.c. voltage and suitable series or shunt resistors.

OHM'S LAW. A fundamental electrical law which expresses the relationship between voltage, current, and resistance in a direct current circuit, or the relationship between voltage, current and impedance in an a.c. circuit. The three forms of the law in each case are given below, in which E is the pressure in volts, I is current in amperes, R is resistance in ohms and Z is impedance in ohms.

D.C. FORMS

$$E = I \times R$$

$$I = E \div R$$

$$R = E \div I$$

A.C. FORMS

$$E = I \times Z$$

$$I = E \div Z$$

$$Z = E \div I$$

OHMS-PER-VOLT. A sensitivity rating for meters. It is obtained by dividing the resistance in ohms of any meter range by the full scale voltage reading of the meter at that range. The higher the ohms-per-volt rating, the more sensitive is the meter.

OPERATOR. A person whose duties include the adjustment, maintenance and operation of radio transmitting equipment.

OSCILLATION. A condition whereby high-frequency currents are generated in a circuit.

OSCILLATOR. The stage in radio receiver, transmitter or other apparatus in which a vacuum tube and associated parts generate alternating current en-

ergy when fed with direct current energy. Thus, the oscillator stage in a superheterodyne receiver generates an r.f. signal of the correct frequency to produce the i.f. carrier signal when mixed with an incoming station signal. In a transmitter, the oscillator stage generates the carrier frequency of the station or a frequency equal to some definite fraction of the assigned frequency.

OSCILLOGRAPH. A test instrument which records photographically the wave form of a varying current or voltage.

OSCILLOSCOPE. A test instrument which shows visually on a screen the wave form of a varying current or voltage.

OUTLET. A set of terminals from which electric power may be obtained. Thus, power at the a.c. line voltage may be obtained from a wall outlet in a building connected to an a.c. power system.

OUTPUT. The useful electrical energy delivered by a radio receiver, a.f. amplifier, electrical generator, or any other signal or power source.

OUTPUT IMPEDANCE. The impedance as measured between the output terminals of a radio device, receiver or amplifier at a definite frequency or at a predominant frequency in the audio range which the device is a handle. For maximum efficiency, the load impedance should match or be equal to this output impedance.

OUTPUT METER. A meter connected to the output of a receiver or amplifier for the purpose of measuring variations in output signal strength.

OUTPUT STAGE. The final stage in a receiver or a.f. amplifier. In a radio receiver, the output stage feeds the loudspeaker directly. In an a.f. amplifier, the output stage may feed into one or more loudspeakers, a transmission line, or a cutting head in the case of a sound recording system.

OUTPUT TRANSFORMER. An iron-core a.f. transformer used to provide efficient coupling between the output stage of a radio receiver or a.f. amplifier and its load.

OUTPUT TUBE. A tube designed for use in the output stage. It is a power amplifier tube, whereas the other tubes in a receiver are usually voltage amplifier tubes.

OVERCURRENT DEVICE. A protective device, such as a fuse or circuit breaker, which acts almost simultaneously to open a circuit when current in that circuit exceeds a certain predetermined value.

OVERLOAD DEVICE. A protective device, such as a thermally operated or heat-operated switch, that acts to open a circuit when an excessive load and excessive current have continued for long enough to bring temperature of the circuit wires nearly to the danger point.

P

P. A letter used to designate power, the plate electrode of a tube, or the primary winding of a transformer.

P.A. Public address.

PADDER. In a superheterodyne receiver, the trimmer condenser placed in series with the oscillator tuning circuit to control the receiver calibration at the low-frequency end of a tuning range.

PANEL. A sheet of metallic or non-metallic material on which the operating controls of a radio device such as a receiver, transmitter, or p.a. amplifier are mounted.

PANELBOARD. An enclosed panel or panels carrying buses, switches, over-current devices and other control elements in various combinations for the control of lighting, heating or power circuits or relatively small capacity such as used in individual buildings or sections of buildings.

PAPER CONDENSER. A fixed condenser employing foil plates separated by paraffined or oiled paper.

PARALLEL CONNECTION. A connection of two or more circuits or parts between the same terminals of a source or current-supply circuit so that the same voltage difference is applied to all parts so connected and so that the current through each is proportional to the overall voltage and the resistance of the individual parts. The total current is equal to the sum of the currents in all the connected circuits or parts, and the total resistance or the effective resistance of all the parts in parallel is less than the individual resistance of any one of them.

PARALLEL RESONANT CIRCUIT. A tuning circuit consisting of a coil and condenser connected in parallel. At resonance, it offers a high impedance, so that a large value of signal voltage is developed across it at the frequency to which it is tuned.

PEAK. The maximum instantaneous value of a varying voltage or current.

PEAK VALUE. Same as maximum value, which see.

PENTODE. A vacuum tube having five electrodes. Ordinarily these will be the cathode, control grid, screen grid, suppressor grid and anode.

PERIOD. The length of time required for one complete cycle of alternating current or voltage. As an example, the period for 60 cycles per second is 1/60 second.

PERMANENT MAGNET. A piece of steel in which the particles are so lined up that the piece remains magnetized and continues to have a magnetic field without help from any external magnetism.

PERMANENT MAGNET DYNAMIC SPEAKER. A moving coil speaker with its field supplied by a permanent magnet.

PERMEABILITY. A measure of the ease with which magnetic flux or magnetic lines of force may be established in a magnetic circuit. The ratio of the number of flux lines produced by an electromagnet coil having a core of iron or steel to the flux produced by the same coil with no core other than air. The reciprocal of reluctance.

PERMEABILITY TUNING. Tuning of radio by means of adjustable iron-core inductance in place of tuning condenser.

PHASE. In alternating current or voltage, the portion of a cycle or period

through which the current or voltage has passed since going through zero value at the beginning of the cycle or period. The position of the current or voltage is specified in degrees, of which 360 compose a complete cycle or period. See Lag, Lagging Current, and Lead.

PHILLIPS SCREW. A screw having an indented cross in its head in place of a slot.

PHONE. A headphone.

PHONOGRAPH. A device for converting mechanical vibrations into sound waves. **Electrical Phonograph.** A phonograph in which the motor derives its power from an electrical source. **Mechanical Phonograph.** A phonograph utilizing a hand-wound type of mechanical motor.

PHONOGRAPH CONNECTION. A set of two terminals sometimes provided at the back of a radio receiver for making connections to a phonograph pick-up. The terminals connect to the input of the a.f. amplifier. This connection permits use of the entire audio amplifier and loudspeaker to reproduce phonograph records.

PHONOGRAPH OSCILLATOR. An r.f. oscillator arranged for modulation by the output of a phonograph pick-up, so that the resulting modulated r.f. signal can be fed to the antenna and ground terminals of a radio receiver. This permits using the entire receiver (rather than just the a.f. amplifier) for amplifying and reproducing phonograph records.

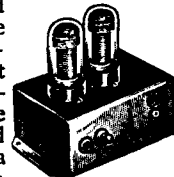

PHONOGRAPH PICK-UP. A device which converts variations in the grooves of a phonograph record into corresponding audio signals. It consists essentially of a needle which converts record groove variations into mechanical movements, and a crystal, dynamic or photoelectric system which converts these mechanical movements into the audio signals.



PHOSPHOR. Any fluorescent material used for the screen in a cathode-ray tube, an X-ray viewing screen, or a fluorescent lamp. The phosphor becomes luminous when struck by a stream or beam of electrons.

PHOTOCELL. An evacuated or gas-filled bulb containing two electrodes, one of which is coated with substances which readily emit electrons when struck by visible light. With a voltage difference applied to the electrodes, current through the cell is proportional to the light reaching the light-sensitive electrode.

PHOTOCONDUCTIVE CELL. A device utilizing the property of selenium by which its electrical resistance varies with changes of visible light striking the selenium or the cell.

PHOTOELECTRIC CELL. Any device in which visible light varies the flow of electric current through the cell, thus forming a unit in which changes of light produce corresponding changes of electric current.

PHOTOTUBE. A photocell, which see.

PHOTOVOLTAIC CELL. A device containing two electrodes immersed in a liquid electrolyte, capable of producing an emf proportional to the visible light that falls upon one of the electrodes. It is essentially a primary voltaic cell whose output varies with changes of light.

PICTURE ELEMENT. In a television system, the smallest portion of a picture or scene which is individually converted into an electrical signal and transmitted.

PICTURE FREQUENCY. In television, the number of complete pictures which are scanned and transmitted in one second.

PICTURE TUBE. In a television receiver, the cathode-ray tube on whose screen is reproduced the scene being scanned at the television transmitter.

PIEZO-ELECTRIC EFFECT. A property of crystals of quartz and some other substances by which their form or dimensions are varied by application of potential differences to opposite faces. The original dimensions and manner of cutting of the crystal determine the frequency of applied voltage at which the crystal is resonant and vibrates most freely, this being the frequency which will be maintained within very narrow limits in a suitable resonant circuit containing the crystal.

PIGTAIL. A flexible connection between a stationary terminal and a part or terminal which has a limited range of motion.

PILOT LAMP. A small lamp mounted on the panel of a radio receiver to illuminate the tuning dial, or mounted on the panel of other radio apparatus to indicate when the apparatus is turned on. 

PLASTIC. A general term used in connection with any of the black or colored materials used for molding radio receiver cabinets, control knobs, tube bases, sockets, and the insulating portions of many other radio parts. It is an excellent insulating material and has a natural smooth glossy surface which requires no finishing or polishing operations after molding.

PLATE. The anode in a radio tube. It is usually at a high positive potential with respect to the cathode, and therefore attracts the electrons emitted by the cathode.

PLATE CIRCUIT. A circuit including the plate voltage source and all other parts connected between the cathode and plate terminals of a radio tube.

PLATE CURRENT. The current flowing through the plate circuit of a radio tube and between the plate and cathode inside the tube. The electrons which make up the plate current always flow in the direction from the cathode to the plate.

PLATE SUPPLY. The voltage source used in a vacuum tube circuit to place the plate at a high positive potential with respect to the cathode. The plate supply voltage is always higher than the actual plate voltage, because of the voltage drops across resistance in the plate circuit.

PLATE VOLTAGE. The d.c. voltage existing between the plate and cathode terminals of a radio tube.

PLUG. A connecting device at the end of a flexible cord, used for making an instantly-removable connection to a corresponding terminal jack or outlet.

PLUG FUSE. A fuse so mounted as to screw into its holder.

PLUG-IN COIL. A coil having as its terminals a number of prongs arranged to fit into a socket mounted on the radio chassis. With this arrangement, the tuning range of a receiver or transmitter can be changed simply by pulling out one coil and inserting another in the socket. 

POLARITY. In a radio part or circuit, the quality of having two opposite charges, one negative and the other positive. In a magnetic circuit or part, the quality of having two opposite poles, one North and the other South.

POLE. One end of a magnet. One electrode of a battery.

POLICE CALLS. Broadcasts or calls made by police radio stations. Many modern single-band receivers are capable of picking up police radio stations operating on frequencies between 1626 kc. and 1712 kc. (just beyond the high-frequency end of the broadcast band).

POLARIZATION. Reduction of the terminal voltage of a cell, due to formation of hydrogen gas on the surfaces of the cell electrodes and to the accompanying counter-emf produced in the cell.

POLARIZED. 1. A polarized bell or relay is one whose armature is a permanent magnet and which operates in accordance with the direction of current through its windings. 2. Marked, colored, or otherwise identified for the correct connection of positive and negative wires, grounded and ungrounded wires, or other conductors.

PORTABLE APPLIANCE. An appliance to which current is furnished through a flexible cord and attachment plug, permitting the appliance to be moved and connected to various sources.

POSITIVE. A term used to describe a terminal having fewer electrons than normal, so that it attracts electrons in seeking to return to its normal state. Thus, electrons flow into the positive terminal of a voltage source.

POSITIVE CHARGE. The electrical condition of a body which has less than the normal quantity of negative electrons, so that the body has less negative electricity than one which is uncharged or is neutral.

POSITIVE FEEDBACK. Regeneration, causing an increase in signal strength.

POSITIVE MODULATION. In television, a method of transmission in which an increase in scene illumination causes an increase in the radiated power of the transmitter.

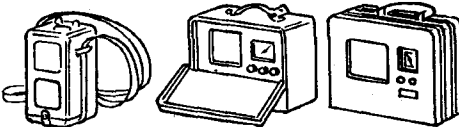

PORTABLE RECEIVERS

PORTABLE RECEIVER. A completely self-contained radio receiver

having the loudspeaker, all necessary batteries, and a loop antenna built into a compact carrying case. Terminals are sometimes provided for external antenna and ground connections.

POTENTIAL. A characteristic of a point in an electric circuit determined by its electric charge in comparison with the charge at some other reference point, thus making the point considered more positive or more negative than the reference point.

POTENTIOMETER. A resistance unit having a rotating contact arm which can be set at any desired point on the resistance element. The total available voltage is applied to the fixed end terminals of the resistance element, and the output circuit is connected between the movable contact and one end terminal. Rotating the movable contact thus varies the proportion of the total voltage which is transferred to the output circuit. The volume control of a receiver or p.a. amplifier is generally a potentiometer. 

POWER. The rate at which electrical energy is delivered and consumed. Electrical power is measured in watts.

POWER AMPLIFIER STAGE. An audio amplifier stage which is capable of handling a relatively large amount of audio power without distortion. An r.f. amplifier stage in a transmitter which serves primarily to increase the power of the r.f. carrier signal.

POWER FACTOR. The ratio of the voltage and current, or volt-amperes, that do useful work in an alternating-current circuit or alternating-current equipment to the total voltage and current, volt-amperes, flowing in the circuit. In circuits containing much inductance or much capacitance in addition to their resistance the total current is more than the current that produces useful power, consequently such circuits have relatively low power factors. In circuits containing only resistance all the current and voltage do useful work, consequently the ratio is one-to-one or is unity, this being the highest possible power factor.

POWER FACTOR CORRECTION. The addition of capacitance to an alternating-current circuit containing a great deal of inductance, so that the capacitive reactance balances out a large portion of the inductive reactance, thus lessening the amount of current that does no useful work and making a higher power factor for the circuit. Inductance might similarly be added to a circuit containing excessive capacitance.

POWER LEVEL. The amount of electrical power passing through a given point in a circuit. Power level can be expressed in watts, in decibels, or in volume units.

POWER LEVEL INDICATOR. An a.c. voltmeter which is calibrated to read in terms of audio power level.

POWER PACK. The power supply unit of a radio receiver, amplifier, transmitter, or other radio apparatus. Its function is to convert the available power line or storage battery voltage to the values required by filament, grid and plate circuits.

POWER TRANSFORMER. An iron-core transformer having a primary winding which is connected across the a.c. power line, a high-voltage secondary winding for the power pack rectifier tube, and one or more low-voltage secondary windings which supply the required a.c. voltages to the tube filaments.

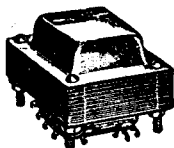

POWER OUTPUT TUBE. A radio tube especially designed for use in the a.f. output stage of a radio system. It is capable of handling much greater current than the ordinary amplifier tube, and hence delivers high output power.

PRESELECTOR. That circuit or r.f. amplifier stage in a superheterodyne receiver which amplifies the incoming modulated r.f. signal before it is converted to the i.f. signal by the oscillator-mixer-first detector section.

PRI. Primary.

PRIMARY. First in order of time, placement, development or importance.

PRIMARY CELL. A voltaic cell or battery cell in which, when current is produced, the chemicals of the cell elements are consumed or changed to such forms that they cannot be restored to their original active condition by sending a reverse current through the cell, thus making the cell useless after having delivered a certain number of ampere-hours of electricity.

PRIMARY WINDING. The input winding of a transformer. It can be identified by the fact that r.f., a.f. or power line alternating current or pulsating d.c. is sent through this winding.

PROTON. One of the positively charged particles which, together with electrons (negatively charged particles), make up the structure of an atom.

PUBLIC ADDRESS AMPLIFIER. An audio amplifier capable of supplying sufficient audio power to loudspeakers for adequate sound coverage of public gatherings.

PUBLIC ADDRESS SYSTEM. A complete system for reproducing voice and speech with adequate volume for large public gatherings. It includes one or more microphones, a powerful audio amplifier with suitable power supply, and a sufficient number of loudspeakers to give coverage of the auditorium, stadium or other large space. Most installations also include a phonograph which may or may not be of the automatic record changer type.

PULSATING CURRENT. A current which changes in value but not in direction. It can be considered as a direct current combined with a smaller value of alternating current.

PULSE. A momentary sharp change in a current or voltage.

PUSH-BACK HOOP-UP WIRE. Tinned copper hook-up wire covered with a loosely braided cotton insulation which can be pushed back from the end of a wire length with the fingers to expose sufficient bare wire for a connection. Radio men use this type of wire almost exclusively for experimental and repair work.

PUSH-BUTTON TUNER. A tuning unit which automatically tunes a radio re-

ceiver to a station when the button assigned to that station is pressed. In electrical automatic push-button tuning, the button actuates switches which connect a set of pre-adjusted trimmer condensers into the receiver tuning circuits. In electromechanical automatic push-button tuning, the button controls the starting and stopping circuits of a small motor which rotates the regular gang tuning condenser of the receiver. In mechanical automatic push-button tuning, pressure on the button is transferred by a lever or cam system into a force which rotates the gang tuning condenser to the correct position for the desired station.

PUSH-PULL CIRCUIT. A two-tube audio output circuit so arranged that both tubes operate simultaneously and their individual a.f. plate currents add in the common load to give twice the output of a single tube. This circuit arrangement has the added advantage that it balances out all even harmonics which would otherwise cause distortion.

PUSH-PULL TRANSFORMER. An iron-core a.f. transformer designed for use in a push-pull amplifier circuit. If it is the input transformer, it will have a center-tapped secondary winding. If it is the output transformer, it will have a center tapped primary winding.

PUSH-PUSH CIRCUIT. A two-tube audio output circuit so arranged that the tubes operate alternately into a common load.

Q FACTOR. A rating used to express certain characteristics of coils and resonant circuits. It is obtained by dividing reactance by ohmic resistance.

Q SIGNAL. One of the three-letter abbreviations in the International List of Abbreviations, used to represent complete sentences in radio telegraphy. When the question form of the sentence is intended, the code signal for an interrogation mark is sent after the abbreviation. Thus QRM means "I am being interfered with," and QRX means "Are you being interfered with?"

QUARTZ-CRYSTAL. A thin slab about the size of a half-dollar, cut from a natural crystal of the mineral quartz and carefully ground to a thickness which will make it vibrate at the desired natural frequency when supplied with energy. It is used as the master carrier frequency source in the crystal oscillator stage of a radio transmitter.

R

R. Resistance.

RACEWAY. Any enclosure designed for and used only for holding wires, cables or bus-bars; includes all types of conduit, whether of metal or of insulating material, and all similar wire channels.

RADIATION. The process wherein the transmitting antenna system of a radio station converts the modulated r.f. output of the transmitter into radio waves which travel away from the station through space.

RADIATION PATTERN. A diagram showing how well an antenna system

radiates or picks up radio waves in various directions.

RADIO. Communication by means of radio waves. Also, a receiving set capable of picking up radio waves and reproducing the intelligence they convey. This intelligence may consist of speech, music, code signals, writing, printed matter, diagrams, photographs, motion pictures, actual scenes, etc. In space radio, which is the conventional form, radio waves are transmitted through space. In wired radio, the radio waves are guided by conductors.

RADIO BEACON. A stationary radio transmitter which sends out special identifying signals continuously. Radio receivers on ships at sea and on aircraft in flight can tune to a radio beacon to determine their direction and position with respect to the beacon location.

RADIO BROADCASTING. A one-way transmission of voice and music to anyone within receiving range of the radio station.

RADIO COMPASS. A radio direction finder used chiefly in marine and aircraft radio stations for navigational purposes.

RADIO CONTROL. The control of moving objects such as airplanes, automobiles, ships, torpedoes, etc., by means of signals transmitted over radio waves from the transmitter location to special radio receiving equipment in the object being controlled.

RADIO FREQUENCY. Any frequency in the radio spectrum above the highest audible frequency, which is about 20,000 cycles. This term is also used in connection with radio parts designed for use at frequencies higher than the audio frequency range. Abbreviated r.f.

RADIO FREQUENCY AMPLIFIER. A vacuum tube amplifier stage to provide amplification at radio frequencies. In a t.r.f. receiver, all stages ahead of the detector are r.f. amplifier stages. In a superheterodyne receiver, the amplifier stage sometimes used ahead of the first detector (in the pre-selector) is an r.f. amplifier stage.

RADIO FREQUENCY CHOKE. A choke coil designed to have high impedance at radio frequencies, so that it limits or blocks the flow of r.f. currents.

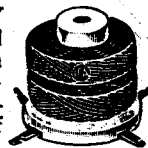

RADIO FREQUENCY TRANSFORMER. An air-core or pulverized iron-core transformer used in r.f. circuits.

RADIO METAL LOCATOR. A radio instrument which indicates the presence of metal within its operating range by a change in meter reading or a change in a tone signal heard in headphones. Used for determining positions of buried pipe lines, buried metal objects, metal objects concealed in the clothes of prisoners, metal objects imbedded in logs about to be sawed, deposits of metallic minerals, etc.

RADIO METEOROGRAPH. A combination meteorograph and radio transmitter carried aloft by an unmanned gas-filled rubber balloon and so designed that it will transmit back to earth radio signals which can be interpreted in terms of the pressure, tem-

perature and humidity at regular intervals during the ascent of the balloon into the stratosphere. When the balloon bursts, the instrument is lowered to earth by a parachute.

RADIO PROSPECTING. Use of radio equipment to locate mineral or oil deposits.

RADIO RECEIVER. An instrument which amplifies radio frequency signals, separates the r.f. carrier from the intelligence signal additionally in most cases, then converts the intelligence signal back into the original sound waves.

RADIOSONDE. A radio meteorograph.

RADIO TELEGRAPHY. Radio communication by means of the Internal Morse Code.

RADIO TELEPHONE TRANSMITTER. A transmitter capable of sending voice and music, as contrasted to a radiotelegraph transmitter which can send only code.

RADIO TELEPHONY. Two-way voice communication between two or more stations by means of radio waves.

RADIOTRICIAN. A trained radio serviceman.

RADIO WAVE. A combination of electric and magnetic fields varying at a radio frequency, and capable of traveling through space at the speed of light. It is produced by feeding the output of a radio transmitter to the transmitting antenna, and may carry modulation.

RAINTIGHT. So constructed or protected that exposure to a beating rain will not cause entrance of water into the enclosure.

R.C.A. LICENSED. Manufactured under a licensing agreement which permits use of patents controlled by the Radio Corporation of America.

REACTANCE. Opposition offered to the flow of alternating current by the inductance or capacity of a part. Reactance is measured in ohms, and depends upon the frequency of the alternating current as well as upon the electrical value of inductance or capacity. A condenser has capacitive reactance, and a coil has inductive reactance. The letter X is used to designate reactance.

RECEPTACLE. A device which holds or supports and at the same time makes electrical connections to a lampholder, lamp base, cord plug, or other attachment device.

RECEPTACLE OUTLET. An outlet equipped with one or more receptacles intended to receive attachment plugs or cord plugs, not with receptacles of the screw type.

RECORD PLAYER. A motor-driven turntable and a crystal or magnetic phono pick-up used for converting a phonograph record into audio frequency signals. These signals must be fed into the audio section of a radio receiver or into a separate audio amplifier for additional amplification before they can be reproduced as sound waves by a loudspeaker. When the amplifier and loudspeaker are built into the same cabinet with the record player, the combination is generally called an electric phonograph.

RECORDER. An instrument which makes a permanent record of a varying electrical signal. Thus, code messages are recorded on paper tape by a code recorder. Music and voice are recorded on discs or other materials by a sound recorder. Pictures and printed matter transmitted by radio are reproduced on paper by a facsimile recorder.

RECTIFIER. A device which changes an alternating current into a pulsating direct current. It may be a vacuum tube, gaseous tube, crystal, vibrator or copper-oxide device.

RECTIFIER METER. A moving coil direct-current meter equipped with a rectifier which changes alternating current or voltage to be measured into direct current or voltage which will operate the meter and cause it to indicate.

REGENERATION. A method of securing output from an amplifier by feeding a part of the amplifier output back to the amplifier input in such a way that reinforcement of the input signal is obtained. With this arrangement, a signal may pass through the same amplifier over and over again, with an increase in strength each time.

REGENERATION CONTROL. A rheostat, potentiometer, or variable condenser which is used in a regenerative receiver to control the amount of signal which is fed back from output to input in the regenerative detector stage.

REGENERATIVE DETECTOR. A vacuum tube detector in which international feedback of r.f. energy from the plate circuit to the control grid circuit produces regeneration.

REGENERATIVE RECEIVER. A radio receiver which employs controlled regeneration to increase the amplification provided by a vacuum tube stage (usually the detector stage).

RELAY. An electromagnetic device which permits control of current in one circuit by a much smaller current flowing in another circuit.

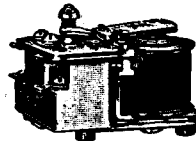

REMOTE CONTROL. Operation of radio transmitting or receiving equipment from a remote point.

RESISTANCE. The opposition which a device or material offers to the flow of direct or alternating current. The opposition which results in production of heat in the material carrying the current. Resistance is measured in ohms, and is usually designated by the letter R.

RESISTANCE COUPLING. A type of coupling in which a resistor and condenser provides a path for signal energy between two circuits.

RESISTIVITY. The resistance in ohms which a unit cube of a material offers to the flow of electric current.

RESISTOR. A radio part which offers resistance to the flow of electric current. Its electrical size is specified in ohms or megohms, (one megohm equals 1,000,000 ohms). A resistor also has a power-handling rating in watts, indicating the amount of power which can safely be dissipated as heat by the resistor.

RESONANCE. The condition in a circuit whose inductive reactance and capacitive reactance are equal, allowing them to completely balance or neutralize each other and leaving only the resistance of the circuit to oppose flow of current in it.

RESONANT FREQUENCY. The frequency which produces resonance in a coil-condenser tuning circuit. In a series resonant circuit, the largest current flow occurs at the resonant frequency. In a parallel resonant circuit, the largest voltage is developed across the circuit at the resonant frequency.

RESTING FREQUENCY. The assigned carrier frequency of a radio station which employs the frequency modulation system of broadcasting. The resting frequency is radiated only during intervals when no sound waves are being transmitted.

RETENTIVITY. A measure of the ability of a permanent magnet to retain its magnetic strength.

RETRACE PERIOD. The time during which the blanked scanning beam in a television tube returns to its starting point on the field.

R.F. Radio frequency.

RHEOSTAT. A resistance unit which can be varied in ohmic value so as to control the flow of current in the circuit of which it is a part.

RIGID METAL CONDUIT. Piping or heavy tubing of mild steel having pipe-thread ends and used with similarly threaded fittings for the enclosure and support of insulated wires in an electrical system.

RIM-DRIVE. A method of driving a phonograph or sound recorder turntable with a rubber-covered wheel which is in contact with the rim of the turntable. The wheel is powered by an electric motor.

RIPPLE. An alternating current component which is present in the output of a d.c. voltage supply such as a power pack or d.c. generator.

R.M.A. Radio Manufacturers Association, an organization of leading manufacturers in the radio industry. Its work involves standardizing sizes and designs of radio parts, standardizing of color markings on parts (such as the R.M.A. color code for resistors and condensers) and standardizing of radio terms and definitions.

R.M.A. COLOR CODE. A standard method of designating resistor values by colored markings. The code is given at the back of this book.

R.M.S. Root mean square value, which is the effective value of an alternating current. It corresponds to the equivalent direct current value which will produce the same heating effect. Unless otherwise specified, alternating current values are always r.m.s. values.

ROENTGEN RAYS. Same as X-rays.

ROSIN-CORE SOLDER. Solder which has as its core the correct amount of rosin flux for effective radio soldering work. The rosin is released automatically as the solder is applied to the heated joint.

ROTOR. In a generator, motor or other electric machine having a rotating member, the member that rotates. A word used chiefly when referring to alternating-current machines.

ROTOR PLATES. The movable plates of a variable condenser. They are usually connected directly to the metal frame of the condenser.

ROTARY BEAM ANTENNA. A highly directional short wave receiving or transmitting antenna system mounted on a high pole or mast in such a way that it can be rotated to any desired positions either manually or by an electric motor drive.

ROTARY SWITCH. A rotary switch which is operated by rotating its control knob.



R.P.M. Revolutions per minute.

S

S. A letter sometimes used to designate the secondary winding of a transformer.

SAPPHIRE. A gem used in the tips of high-grade phonograph needles and in cutting needles used with sound recorders.

SCALE. A series of marks printed on a flat surface over which the pointer of a meter moves. The value of the mark directly behind the pointer corresponds to the meter reading.

SCANNING. In television, the process by which an image of a scene to be transmitted and reproduced has its lights and shades changed into corresponding changes of voltage and current for each small element or area of the scene, these electrical changes being transmitted and then reconverted into lights and shades at the receiver.

S.C.C. Single cotton covered insulation on a wire.

S.C.E. Single cotton covering over an enamel insulating layer on a wire.

SCHEMATIC DIAGRAM. A diagram which shows electrical connections of a radio device by means of symbols which are used to represent the radio parts.

SCRATCH FILTER. A filter circuit used in connection with a phonograph pick-up to block those frequencies at the higher end of the audio range at which needle scratch is most prominent.

SCREEN. In a television picture tube or a cathode-ray tube, the internal coating of fluorescent material which is made to glow by the electron beam in reproducing pictures or lines.

SCREEN GRID. An electrode mounted between the control grid and plate of a vacuum tube for the purpose of reducing the capacity between these two electrodes.

SCREEN GRID TUBE. A vacuum tube having a screen grid. It may be a tetrode (four-element tube) or a pentode (five-element tube). In the latter case, it is more often called a screen grid pentode.

SCREEN GRID VOLTAGE. The d.c. voltage which is applied between the screen grid and the cathode of a vacuum tube to make the screen grid highly positive with respect to the cathode.

SEC. Secondary.

SECONDARY CELL. A d.c. voltage source which is capable of storing elec-

trical energy. When exhausted, it can be recharged by sending direct current through it in the reverse direction. Each cell of an ordinary storage battery is a secondary cell.

SECONDARY EMISSION. Emission of electrons from a cold electrode when it is hit or bombarded by high-speed electrons.

SECONDARY WINDING. The coil or winding of a transformer which is connected to the load, the coil from which power leaves the transformer.

SECONDARY WINDING. Any of the output windings in a transformer.

SELECTIVITY. The degree to which a radio receiver is capable of reproducing signals of one station while rejecting signals from all other stations.

SELF-BIAS. Referring to a vacuum tube stage which produces its own grid bias voltage. Plate current flowing through a resistor in series with the cathode lead produces across this resistor the voltage drop used for grid bias purposes. Also called automatic C bias.

SELF-INDUCTANCE. The property of a circuit whereby any change of current flowing in the circuit produces a counter emf that opposes the change that is taking place, an emf that tends to prevent an increasing current from increasing, and tends to prevent a decreasing current from decreasing. Measured in henrys. The symbol is *L*.

SENSITIVITY. In electrical measuring instruments, a measure of the current, voltage, or power required to operate the meter itself and to cause its indicator to move. The less the required power the higher is the sensitivity.

SERIES CONNECTION. A connection in which the same current must flow through all of the series-connected parts. When dry cells or batteries are connected in series so that their voltage add, the minus terminal of one cell must be connected to the plus terminal of the next cell.

SERIES-PARALLEL. Descriptive of a circuit or part of a circuit in which some parts or elements are connected together in series, with these series groups connected together in parallel; or parts connected in parallel and the groups in series.

SERIES RESONANT CIRCUIT. A circuit in which a coil and condenser are connected in series, and have values such that the inductive reactance of the coil will be equal to the capacitive reactance of the condenser at the desired resonant frequency. At resonance, the current through a series resonant circuit is a maximum.

SERIES WINDING. In a motor, generator or other electric machine, a winding in which flows all the current that enters or leaves the machine.

SERVICE. The conductors and equipment which deliver electric energy and power from a transformer, feeder or main of a public service distribution system to the wiring system of a building or premises in which the power is utilized.

SERVICE AREA. The region around a broadcast station in which its signal

strength is strong enough to insure satisfactory reception at all times.

SERVICE ENTRANCE. Descriptive of equipment and conductors used at the point where building wiring connects to the service.

SETTING. The current at which or in excess of which a circuit breaker or other adjustable protective device will operate to open its circuit.

SG. Letters used to designate the screen grid electrode of a vacuum tube.

SHADED POLE MOTOR. An alternating-current induction motor which is self-starting on single-phase current supply because of a partial displacement of magnetic lines or flux at the field poles through auxiliary currents and flux produced in closed conductive rings around parts of the pole tips.

SHADOW TUNING INDICATOR. A tuning meter which has a small piece of cardboard attached to its pointer, with a pilot lamp mounted behind the pointer so that a shadow is thrown upon a glass screen. The meter is so constructed and connected into a radio receiver circuit that the shadow will be narrowest when the receiver is accurately tuned to a station.

SHIELD. A metal can or housing placed around a radio part to prevent its electric and magnetic fields from affecting nearby parts or to prevent other fields from affecting it.

SHIELDED WIRE. Insulated wire having around it a shield of tinned braided copper wire.

SHORT CIRCUIT. A low-resistance connection, usually accidental, occurring between the two sides of a circuit or between any two circuit terminals; it often results in excessive current flow and damage to some parts.

SHORT WAVES. Wavelengths shorter than those included in the broadcast band, hence waves shorter than 200 meters. Short waves correspond to frequencies higher than the highest broadcast band frequency of 1600 kilocycles.

SHORT-WAVE CONVERTER. A radio device which can be connected between a broadcast receiver and its antenna system to permit reception of higher-frequency stations which the receiver could not otherwise receive. It consists essentially of an oscillator-mixer-first detector arrangement like that used in a superheterodyne receiver, and serves to convert the high-frequency signals to a broadcast band frequency which can be handled by the regular receiver.

SHUNT. A resistor placed across the terminals of an ammeter to allow a definite part of the circuit current to go around the meter. Any parallel-connected part, or the act of placing one part in parallel with another.

SHUNT WINDING. In a motor, generator or other electric machine, a winding through which flows only a portion of the total current entering or leaving the machine; a winding which is in parallel with the armature windings.

SIGNAL. A radio wave or alternating current which carries intelligence of any form. More generally, any alternating current having other than an a.c. power line frequency.

SIGNAL GENERATOR. A test instrument used by radio servicemen to produce a modulated or unmodulated r.f. carrier signal having a known radio frequency value, sometimes also at a known voltage. It is used as a signal source during alignment of a radio receiver and when hunting for the defective part in an improperly operating receiver. An all-wave signal generator has several ranges, and hence can be set to any carrier frequency which an all-wave receiver can receive.

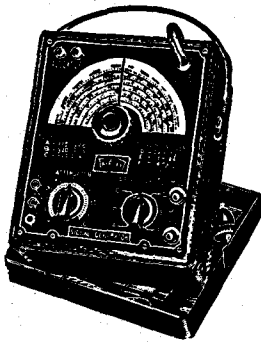

SIGNAL-TO-NOISE RATIO. The ratio of the intensity of a desired signal at any point to the intensity of noise there is to interfere with reception.

SIGNAL TRACING. A radio receiver servicing technique which involves tracing the progress of a radio signal through an entire receiver, stage by stage, while the receiver is in operation. Measurements which are made during this procedure by a special signal-tracing test instrument indicate when the defective part or stage has been reached.

SINE WAVE. The rise, fall and reversal of an alternating current or voltage which would be induced in a conductor rotating at constant speed in a uniform magnetic field and moving around a circle in that field. The ideal form of an alternating wave.

SINGLE-BUTTON CARBON MICROPHONE. A microphone having a carbon-filled button on only one side of its diaphragm.

SINGLE-POLE SWITCH. A toggle or knife switch having only one movable contact arm or blade.

SINGLE-THROW SWITCH. A toggle or knife switch in which each movable contact arm or blade always touches the same contact when closed.

SKIP DISTANCE. The distance between the farthest point reached by the ground wave of a radio station and the nearest point at which the reflected skip wave comes back to earth. This skip effect usually occurs only during high-frequency transmissions (short-wave transmissions).

SKY WAVES. Radio waves which travel up into the sky from the transmitting antenna and are reflected back to earth by the Kennelly-Heaviside ionized layer.

SLIDE RULE DIAL. A type of tuning dial used on radio receivers, in which a vertical marker moves horizontally over long straight scales resembling the scales of a slide rule.

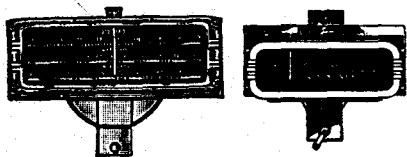

SLIDE RULE DIALS

SNAP SWITCH. A switch in which movement of the control member first places tension on a spring, after which the spring tension is released to suddenly open (and usually to suddenly close) the switch contacts.

SOCKET. A mounting device for tubes, plug-in coils, plug-in condensers, plug-in resistors and crystals, having holes with spring clips arranged to fit and grip the terminal prongs of the part being plugged in. Also, a bayonet or screw type socket for pilot lamps.

SOLDER. An alloy of lead and tin which melts at a fairly low temperature and is used in radio for making permanent electrical connections between parts and wires.

SOLDERING IRON. A device used to apply heat to a joint which is to be made permanent by soldering.

SOUND. A vibration of a body at a rate which can be heard by human ears. The extreme limits of human hearing are about 20 cycles and 20,000 cycles. Sound can travel through any medium which possesses the ability to vibrate; the resulting traveling vibrations are called sound waves.

SOURCE. A term sometimes used to describe the part which is supplying electrical energy or radio signals to a circuit.

SPACE CHARGE. A gathering of electrons near the cathode of a vacuum tube. Being negative, it tends to limit the number of electrons which can reach the plate, and hence limits the plate current.

SPAGHETTI. Heavily varnished cloth tubing sometimes used to provide additional insulation for radio circuit wiring.

S.P.D.T. SWITCH. Single pole, double throw switch.

SPECIFIC GRAVITY. The ratio of the weight or mass of a substance to the weight or mass of an equal volume of pure water at the same temperature, or sometimes at a reference temperature of four degrees centigrade.

SPEED CONTROLS. In a television receiver, the adjustable controls that set the operating frequencies of the vertical and horizontal oscillators at values which permit them to fall into step with or synchronize with the incoming signals.

SPIDER. A highly flexible fiber ring which serves to center the voice coil of a dynamic loudspeaker without appreciably hindering the in-and-out motion of the voice coil and its attached diaphragm.

SPLICE. A joint between two wires which possesses mechanical strength as well as good electrical conductivity.

SPLIT PHASE MOTOR. An alternating-current induction motor which is made self-starting on single-phase current by using two stator windings, in one of which the current is displaced in phase with reference to that in the other winding to produce a rotating field somewhat like the rotating field secured from two-phase current.

S.P.S.T. SWITCH. Single pole, single throw switch.

SQUEALING. A condition in which a high-pitched note is heard along with the desired radio program. It can be due to interference between stations or to a number of other causes.

SQUIRREL CAGE MOTOR. An alternating-current induction motor in which the conductors on the rotor consist of bars parallel to the rotor axis or shaft, joined together at the front and rear of the armature by conductive rings. The conductors, neglecting their supports, would have the general form of a squirrel cage.

S.S.C. Single silk covered wire.

STAND-OFF INSULATOR. An insulator used to support a wire at a desired distance away from the building or other support on which the insulator is mounted.

STATIC. Interfering noises heard in a radio receiver due to radio waves created by atmospheric electrical disturbances such as discharges of lightning.

STATOR. The fixed set of plates in a variable condenser.

STATOR. The parts of an alternating-current motor or generator on which are the stationary windings.

STEP-DOWN TRANSFORMER. A transformer in which the secondary winding has fewer turns than the primary, so that the secondary delivers a lower voltage than is supplied to the primary.

STEP-UP TRANSFORMER. A transformer in which the secondary winding has more turns than the primary so that the secondary delivers a higher voltage than is applied to the primary.

STORAGE BATTERY. One or more secondary or storage cells connected together, usually in series.

STORAGE CELL. A secondary cell. More specifically, one of the cells of the ordinary automotive storage battery, delivering a voltage slightly higher than two volts and capable of being recharged.

STRANDED WIRE. A wire which consists of a number of finer wires twisted together.

SULPHATION. In a lead-acid storage battery, the conversion during discharge of an excessive amount of the active sponge lead and peroxide of lead into inactive sulphate of lead.

SUPERHETERODYNE RECEIVER. A type of radio receiver in which the incoming modulated r.f. signals are amplified a small amount in the preselector, then fed into the frequency converter section (consisting of the oscillator, mixer and first detector) for conversion into a fixed, lower carrier frequency called the i.f. value of the receiver. The modulated i.f. signals are given very high amplification in the i.f. amplifier stages, then fed into the second detector for demodulation. The resulting audio signals are amplified in the conventional manner by the audio amplifier, then reproduced as sound waves by the loudspeaker.

SUPPRESSOR. A resistor inserted in series with the spark plug lead or the distributor lead of an automobile engine to suppress spark interference which might otherwise interfere with reception of radio programs in the auto radio set.



SURFACE METAL RACEWAY. A thin-walled flattened metallic covering and support for insulated wires, de-

signed for mounting on the exposed surfaces of building members, and usually having a removable cover.

SWEEP CIRCUIT. A special oscillator circuit which generates a voltage having a sawtooth wave form suitable for making the electron beam of a cathode ray tube sweep back and forth across the fluorescent screen.

SWITCH. A mechanical device for opening and closing an electrical circuit, or for changing the connections between parts or circuits.

SWITCHBOARD. A large exposed panel or panels carrying on the front, the back, or both front and back, switches, buses, protective devices and instruments for measuring and indicating or recording values of current and voltage in parts of circuits controlled by equipment on the switchboard.

SYMBOL. A simple design used to represent a radio part on a schematic circuit diagram. A letter used in formulas to represent a particular quantity.

SYNC SEPARATOR. In a television receiver, the filter system that separates the synchronizing signal from the other received signals.

SYNC SIGNAL. A synchronizing signal in television.

SYNCHRONIZING SIGNAL. The portion of a television signal that keeps the motions of the electron beam in the picture tube of the receiver in step with or synchronized with motions of the beam in the camera tube at the transmitter.

SYNCHRONOUS. Happening at the same time; having the same alternating phase relations and period; maintaining a frequency exactly proportional to operating speed, or a speed exactly proportional to supply frequency.

SYNCHRONOUS VIBRATOR. A vibrator which serves the dual function of converting a low d.c. voltage to a low a.c. voltage and at the same time rectifying a high a.c. voltage. When used in an auto radio power pack, it eliminates the need for a rectifier tube.

T

TABLE MODEL RECEIVER. A radio receiver having a cabinet of suitable shape and size to permit placing on a table.

TAP. A connection made to a point intermediate between the ends of a coil, a resistor, or other element in a circuit or line.

TELEVISION. Reproduction of a scene, which may include moving objects and persons, at a distance from the point where the scene exists. Television requires the conversion of lights and shades of a scene into variations of voltage and current, transmission of these variations as radio waves, and reconversion at the receiver of the voltage variations into lights and shades, all at practically the same instants that changes are occurring in the distant scene.

TELEVISION CONNECTION. Terminals which permit the use of an ordinary radio receiver in amplifying and reproducing the audio signals as-

sociated with a television program. These terminals simply connect to the input of the audio amplifier in the receiver, just as do the phonograph connection terminals.

TERMINAL. A point to which electrical connections are made.

TEST LEAD. A flexible insulated lead used chiefly for connecting meters and test instruments to a circuit under test.



TEST PROD. A sharp metal point provided with an insulated handle and means for connecting the point to a test lead. It is used for making a touch connection to a circuit terminal.

TETRODE. A four-electrode vacuum tube. Ordinarily, these electrodes will be the cathode, control grid, screen grid, and anode.

THERMAL DEVICES. Devices such as relays and cutouts that are operated usually by the expansion of parts which are heated by flow through them or through adjacent parts of an electric current. Excessive current causes excessive heating, and the expansion that operates the device. In other styles the overheating melts a fusible metal which releases the operating parts.

THERMOCOUPLE. A device that converts heat directly into emf and electric current. The thermocouple consists of two metals, such as copper and constantan, directly in contact at a point which is heated and either directly in contact or connected through a meter or similar unit at a point kept relatively cool. The emf is proportional to the difference between temperatures at the hot and cold junctions.

THERMOCOUPLE METER. A moving coil meter equipped with a thermocouple heated by alternating current to be measured and producing a direct current that actuates the meter.

THERMOSTAT. A device in which changes of temperature cause expansion and contraction of an element whose resulting motion operates switches or other control devices in electric circuits.

THREE-BAND RECEIVER. A radio receiver having three different tuning ranges. One range will always include the broadcast band, and may also include police stations operating on frequencies just above the broadcast band. The other two ranges will usually be from about 2.2 mc. to about 7.5 mc., and from about 7.25 mc. to about 24 mc.

THREE-WAY SWITCH. A switch that connects one of its terminals alternately to two other terminals, used in a circuit for controlling a single lamp from two different locations.

THREE-WIRE SYSTEM. A direct-current supply system in which the voltage from one wire, called the neutral, to either of the others is half that which exists between the other two wires. For example, the voltage from the neutral to either of the "outside wires" may be 110, and between the two outside wires may be 220.

TICKLER. A coil connected to series with the plate circuit for the purpose of feeding a portion of the amplified signal current back into the grid cir-

cuit by induction for repeated amplification. The tickler is used chiefly in regenerative detector circuits.

TIME DELAY DEVICE. A device such as a relay or circuit breaker that operates only after a period of time following some change of current or voltage, or some other action in an electrical system.

TIME SIGNALS. Naval Observatory time signals which are broadcast regularly each day by government radio station NAA in Arlington, Virginia on a number of different frequencies. They can generally be picked up during the final minute of each hour on 9,425 kc. by a good all-wave receiver. These signals are used by army and navy stations, ships at sea, jewelers, and other persons throughout the entire country for setting timepieces. NAA signals are re-broadcast by some broadcasting networks at certain hours.

TOGGLE SWITCH. A small switch operated by means of a lever.

TOLERANCE. The permissible variation from a rated or assigned value.

-tone. The general character of a reproduced radio program as it affects the human ear.

tone CONTROL. A circuit control sometimes provided on a radio receiver to permit strengthening the response at either low or at high audio frequencies at will, so as to make the reproduced radio program more pleasing to a particular audience.

TOP CAP. A metal cap sometimes placed on the top of a vacuum tube and connected to one of the electrodes, usually the control grid.

TORQUE. Turning effort. The effect of a force that tends to cause rotation of parts about a center. An electric motor exerts torque at its shaft when supplied with current, and if the torque is sufficiently great it will cause the shaft to rotate.

TRACKING. A term used to indicate that all of the tuned circuits in a receiver follow the frequency indicated by the tuning dial pointer as the receiver is tuned over its entire tuning range.

TRANSCRIPTION. An electrical transcription, in which a complete radio program is recorded for future use.

TRANSFORMER. A device usually consisting of two insulated windings on a common iron or steel core, in which alternating current supplied to one winding (the primary) induces by electromagnetic induction alternating emf's in the other winding (the secondary) and will produce alternating currents in a conductive circuit connected to the secondary winding. The voltage from the secondary may be higher or lower than that furnished to the primary winding. See Step-Down and Step-Up Transformers.

TRANSMISSION LINE. Any set of conductors used to carry r.f. or a.f. signals or energy from one location to another.

TRANSMITTER. A comprehensive term applying to all of the equipment used for generating and amplifying an r.f. carrier signal, modulating this carrier with intelligence, and radiating the modulated r.f. carrier into space after

it is amplified additionally and fed to the transmitting antenna.

TREBLE. A term sometimes used to designate high audio frequencies.

T.R.F. Tuned radio frequency.

TRIMMER CONDENSER.

A small semi-adjustable condenser, usually adjusted with a screwdriver, and used in the tuning circuits of radio receivers and other radio apparatus to permit accurate alignment of these circuits.



TRIODE. A three-electrode vacuum tube, usually having a cathode, control grid and anode.

TRUE POWER. The power actually consumed in an alternating-current circuit or equipment, is distinguished from the apparent power which would be equal to the number of volts multiplied by the number of amperes input to the circuit. See Power Factor. Power factor is the ratio of true power to apparent power.

TUBE. A vacuum tube, gaseous tube or photoelectric cell mounted in a somewhat tube-shaped glass or metal envelope.

TUBE TESTER. A test instrument used to test the condition of radio tubes.

TUBULAR CONDENSER.

A paper or electrolytic condenser having as its plates long strips of foil which have been rolled into a compact tubular shape.



TUNED CIRCUIT. A resonant circuit, consisting of a coil and condenser which are preset or can be adjusted to give resonance at a desired frequency.

TUNED RADIO FREQUENCY RECEIVER. A receiver in which r.f. amplification is provided by a number of vacuum tube amplifier stages, each of which has one or more circuits which are tuned to resonance at the incoming signal frequency by a section of the gang tuning condenser. The amplified r.f. signals are fed directly into the detector for demodulation.

TUNGAR BULB. A gaseous diode rectifier tube employed in battery chargers.

TUNGSTEN. A pure metal used in radio chiefly for the filaments and other elements of radio tubes.

TUNING. The process of varying the inductance or capacity in a coil-condenser circuit to provide resonance at a desired frequency. Also, the process of setting all of the tuning circuits in a radio receiver simultaneously to a desired frequency by rotating the tuning dial or pressing a button of a push-button tuner.

TUNING EYE. A cathode ray tuning indicator tube.

TUNING INDICATOR. A device which indicates when a radio receiver is tuned accurately to a radio station.

TUNING METER. An ordinary meter connected into a radio receiver circuit for use as a tuning indicator.

TURN. In a coil, one complete loop of wire around the coil form.

TURNTABLE. In a record player or electric phonograph, the motor-driven disc on which the phonograph record is placed. In a sound recorder, the motor-driven disc on which is placed the disc to be cut.

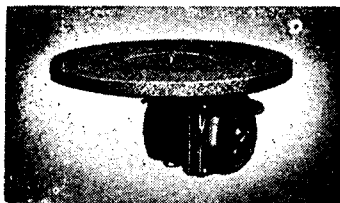

TWO-BAND RECEIVER. A radio receiver having two reception ranges. One will generally cover from 535 kc. to 1720 kc., which includes the broadcast band and some police calls, and the other will generally be between 5.65 mc. and 18.1 mc.

TWO-PHASE. Descriptive of an alternating current circuit or equipment in which there are at the same time two voltages and two currents differing in phase position by 90 electrical degrees.

U

ULTRA-HIGH FREQUENCY. A term usually used to indicate a frequency higher than about 30 megacycles. Abbreviated u.h.f.

UNIVERSAL OUTPUT TRANSFORMER. An iron-core a.f. output transformer having a number of taps on its windings to permit its use in practically any average radio receiver.

UNIVERSAL RECEIVER. A receiver capable of operating from either a.c. or d.c. power.

UNMODULATED. Without modulation. The r.f. carrier signal alone, as it exists during pauses between station programs.

V

V. Voltage. Volts.

VACUUM. A space from which practically all air has been removed.

VACUUM TUBE. A device consisting of a number of electrodes mounted in an envelope or housing from which practically all air has been removed. Also called an electron tube or radio receiver.

VACUUM TUBE VOLTMETER. A test instrument which utilizes the rectification characteristic of a vacuum tube for measuring voltages without affecting the circuit to which the instrument is connected.

VALVE. The term used in Great Britain to designate radio tube.

VARIABLE CONDENSER. A condenser whose capacity may be changed either by varying the space between plates (as in a trimmer condenser) or by varying the amount of meshing between the two sets of plates (as in a tuning condenser).

VARIABLE RESISTANCE. A resistance which can be changed in value while in use.

VERNIER CONDENSER. A small variable tuning condenser which is

placed in parallel with a larger tuning condenser for the purpose of providing a finer adjustment after the large condenser has been set roughly to the desired position.

VERNIER DIAL. A type of tuning dial in which a complete rotation of the control knob makes the tuning condenser shaft rotate only a small fraction of a revolution, thereby permitting fine and accurate tuning.

VERTICAL ANTENNA. A single vertical metal rod, suspended wire or metal tower used as an antenna.

VERTICAL OSCILLATOR. In a television receiver, the oscillator that utilizes the vertical synchronizing and blanking signals, also the equalizing signals, to produce voltages which, when amplified, operate the deflecting plates or coils in the picture tube.

VIBRATOR. An electromagnetic device which converts a d.c. voltage to pulsating d.c. or a.c. It is used in the power packs of auto radios and some public address amplifiers to convert the 6-volt auto storage battery voltage to a low a.c. voltage.



The a.c. voltage is then stepped up by a power transformer, and converted into a high d.c. voltage either by a conventional rectifier tube circuit or by an extra set of contacts on the vibrator itself.

VIDEO. A latin word meaning "I see," applied to television parts and circuits which handle picture signals, and applied also to signals associated with the picture being transmitted.

VIDEO AMPLIFIER. The amplifier for video signals in a television receiver or transmitter.

VIDEO FREQUENCY. One of the frequencies present in the output of a television camera as a result of scanning the image being transmitted. It may be any value from almost zero to well over 4,000,000 cycles.

VIDEO SIGNAL. The changing voltage which corresponds to the changing lights and shades in the image being scanned at the television receiver and reproduced at the receiver.

VOICE COIL. The moving coil which is attached to the diaphragm of a dynamic loudspeaker.

VOLT. The practical unit of voltage. One volt will send a current of one ampere through a resistance of one ohm.

VOLT-OHM-MILLIAMMETER. A test instrument having provisions for measuring voltage, resistance and current. It consists essentially of a single meter having the necessary number of scales, and a switch which places the meter in the correct circuit for a particular measurement.

VOLTAGE AMPLIFICATION. Amplification which increases the voltage of a signal rather than its power. Also, a rating obtained by dividing the a.c. output voltage of an amplifier stage by the a.c. input voltage.

W

VOLTAGE DIVIDER. A resistor, at an intermediate point or points on which are taps that permit taking certain fractions of the overall voltage from between the taps or between the taps and the ends of the resistor. Instead of fixed taps there may be one or more movable contacts that slide on the resistor or are connected to it through switches.

VOLTAGE DROP. A difference in voltage due to flow of current between two points separated by resistance in conductors; equal to the current in amperes multiplied by the resistance in ohms through which the current flows.

VOLTAGE REGULATOR. A device used in a generator circuit or in connection with a generator to maintain a practically constant voltage as there are changes in speed or load.

VOLTAGE REGULATOR TUBE. A two-element gaseous tube used in a.c. radio receivers to keep the input a.c. voltage to the receiver power pack essentially constant despite wide variations in the line voltage. Also used to maintain a constant d.c. potential across a circuit.

VOLTAGE RATING OF A CONDENSER. The maximum sustained voltage which can safely be applied across the terminals of a condenser without causing breakdown of the insulation between condenser plates.

VOLTAGE TO GROUND. In an ungrounded or two-wire circuit, the greatest voltage between the specified conductor and any other conductor. In a grounded circuit, the voltage between a specified conductor and the point in the circuit that is grounded.

VOLTMMETER. A voltmeter and an ammeter in a single case, or sometimes an instrument for measuring watts (volts \times amperes) in a direct-current circuit.

VOLTMETER. An instrument for measuring differences of potential or voltage and indicating the differences directly in a number of volts on its scale.

VOLUME. The intensity of the sound produced by a radio loudspeaker.

VOLUME CONTROL. A device which varies the a.f. output of a receiver or p.a. amplifier, thereby changing the volume of the sound produced by the loudspeaker.

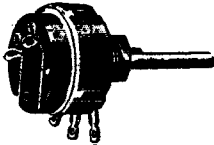

VOLUME EXPANDER. A special manually-adjusted audio circuit which can be set to increase the volume range of a radio program or phonograph record by making the weak passages weaker and the loud portions of the program louder. Volume expanders are also made as self-contained, self-powered units which can be inserted between a phono pick-up and the input terminals of an audio amplifier.

VOLUME UNIT. A recently developed method of expressing the power level in broadcast equipment with reference to a fixed power level of .001 watt.

VU. Volume unit.

WAFER SOCKET. A type of socket in which the clips for gripping the tube prongs are mounted between two wafers or sheets of insulating material.

WATERPROOF. So protected or constructed that moisture will not interfere with satisfactory operation.

WATERTIGHT. So protected or constructed that water will not enter the enclosure.

WATT. The practical unit of electric power. In a direct-current circuit the expended power in watts is equal to the number of volts applied to the circuit multiplied by the number of amperes flowing in the circuit due to the applied voltage. In an alternating-current circuit the watts of power consumed are equal to the number of applied volts multiplied by the number of amperes of current, and multiplied by the power factor. Except in an alternating-current circuit containing no appreciable inductance or capacitance, or containing only resistance, the watts of power will be less than the volt-amperes.

WATTAGE RATING. A rating expressing the maximum power which a device can safely absorb or handle. To determine how high a wattage rating is required for a particular resistor, multiply the value in ohms of the resistor by the square of the current which is to flow through the resistor (resistance \times current \times current), and choose a resistor having a wattage rating approximately twice the computed value so as to give ample margin of safety in operation.

WATTMETER. A meter for measuring and indicating directly in watts on its scale the power being consumed in a circuit or in equipment to which the wattmeter is connected.

WAVE. Any continually varying quantity, such as an alternating current, sound wave, or radio wave.

WAVELENGTH. The distance travelled in a time of one cycle by an alternating current, sound wave or radio wave. This is the same as the distance between successive peaks having the same polarity in the wave. For wave motion in ether the wavelength in meters is equal to the number 299,820,000 divided by the frequency in cycles per second.

WAVE TRAP. A device sometimes connected to the aerial system of a radio receiver to reduce the strength of signals at a particular frequency, such as at the frequency of a strong local station which is interfering with reception of other stations.

WEATHERPROOF. So protected or constructed that exposure to weather will not prevent or interfere with satisfactory operation.

WHEATSTONE BRIDGE. An instrument that allows calculation of values of resistance, inductance or capacitance in parts or circuits connected into the bridge circuit; the calculation involving one ratio of resistances which are adjustable in the bridge circuit, and another ratio in which one value is known and the other is the value of the unknown resistance, inductance or

capacitance. When adjustments make the two ratios equal the bridge is said to be balanced, and the condition of balance may be indicated by a galvanometer or other current-sensitive device.

WHITE LEVELS. The range of voltages through which vary the picture signal portions of a television signal. The maximum white level is at the extreme limit of carrier modulation.

WIND CHARGER. A generator driven by a propeller mounted on or geared to its shaft. The unit must be mounted in a location where wind velocity is sufficient to rotate the propeller; this means it should be on a mast or tower extending well above surrounding trees and buildings. The generator is usually of the d.c. type, and is used for charging a radio storage battery or the batteries of a 32-volt farm lighting plant.

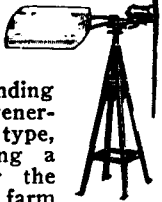

WINDING. One or more turns of wire which make up a continuous coil. Used chiefly in coils, transformers and electromagnetic devices.

WIRE. A metallic conductor having essentially uniform thickness, used in radio chiefly to provide a path for electric currents between two points. It may be bare or covered with an insulating material such as enamel, cotton, linen or silk.

WIRED RADIO. Communication by means of radio waves or silk.

WIRELESS. Radio.

WIRELESS RECORD PLAYER. A motor-driven turntable and phono pick-up mounted in the same cabinet with and r.f. oscillator. The phono pick-up converts a recording into a.f. signals which modulate the r.f. carrier of the oscillator. The resulting signal is radiated through space, as a miniature broadcast signal, and can be picked up by any radio receiver in the same house merely by tuning that receiver to the broadcast band frequency on which the wireless record player is operating.

WIRE-WOUND RESISTOR. A resistor which is constructed by winding a high-resistance wire on an insulating form. The resulting element may or may not be covered with a ceramic insulating layer.

WORK. A force multiplied by the distance through which it causes a mass or weight to move. If a force of one pound causes a movement of one foot, the work done is equal to one foot-pound, this being one of the units in which work may be measured. Work is the result of a force acting against some form of opposition to motion. It is measured as the product of the force and the distance through which it acts.

X

X. A letter used in formulas to designate reactance.

XC. A symbol used for capacitive reactance in ohms.

X-CUT. A piezo-electric crystal or quartz plate cut in such a manner that

X-axis is perpendicular to its faces. Also sometimes called Currie cut and a zero-angle cut.

X-RAYS. A form of radiation which will penetrate opaque substances and affect photographic plates or films, or produce fluorescence, thus showing otherwise invisible differences in structure as lights and shadows. The rays are produced by the striking of an electron stream against a solid object called the target in an X-ray tube.

X'S. Disturbances caused by static.

Y

Y. Symbol used for the admittance in ohms.

Y-AXIS. In a quartz crystal, a line perpendicular to the two diametrically opposite parallel faces. It lies in a plane which is at right angles to the x-axis.

Y-CUT. A piezo-electric crystal cut in such a manner that the y-axis is perpendicular to its faces. Also sometimes

called a face-parallel cut or thirty-degree cut.

Z

Z. A letter used in formulas to designate impedance.

ZERO-BEAT. A condition where two frequencies are exactly the same.

ZERO BIAS. Zero voltage between the control grid and cathode of a vacuum tube, so that these two electrodes are at the same potential.

RMA COLOR CODE FOR RESISTORS

BACKGROUND COLOR		METHOD I		METHOD II	
A	B	C	D	B	A
COLOR BANDS A, B, AND C GIVE VALUE. GOLD OR SILVER BAND D, USUALLY OMITTED, INDICATES TOLERANCE. BLACK BACKGROUND—UNINSULATED. TAN BACKGROUND—INSULATED.		BODY COLOR (A), END COLOR (B), AND DOT OR BAND COLOR (C) GIVE VALUE. GOLD OR SILVER BAND D, USUALLY OMITTED, INDICATES TOLERANCE.			
Color	Figure	COLOR A GIVES FIRST FIGURE OF RESISTOR VALUE.			
BLACK	0	COLOR B GIVES SECOND FIGURE OF RESISTOR VALUE.			
BROWN	1	COLOR C GIVES NUMBER OF CIPHERS FOLLOWING THE FIRST TWO FIGURES.			
RED	2	COLOR D: GOLD BAND INDICATES ± 5% TOLERANCE. SILVER BAND INDICATES ± 10% TOLERANCE. NO BAND INDICATES STANDARD ± 20% TOLERANCE.			
ORANGE	3				
YELLOW	4				
GREEN	5				
BLUE	6				
VIOLET	7				
GRAY	8				
WHITE	9				

EXAMPLES—METHOD I

BAND A	BAND B	BAND C	BAND D	BACKGROUND	RESISTOR VALUE
Green (5)	Black (0)	Black ()	None	Black	50 ohms ± 20%, uninsulated.
Red (2)	Green (5)	Brown (0)	Silver	Brown	250 ohms ± 10%, insulated.
Green (5)	Black (0)	Yellow (0000)	None	Black	500,000 ohms ± 20%, uninsulated.
Orange (3)	Green (5)	Green (00000)	Gold	Brown	3,500,000 ohms ± 5%, insulated.

EXAMPLES—METHOD II

BODY (A)	END (B)	DOT OR BAND (C)	RESISTOR
Green	Black	Black	50 ohms
Red	Green	Brown	250 ohms
Green	Black	Yellow	500,000 ohms
Orange	Green	Green	3,500,000 ohms

The standard color code for resistors was developed by the Radio Manufacturers' Association of marking ohmic values on fixed carbon and metallized resistors. Two marking methods are in common use.

Method I markings are used chiefly on resistors having leads coming straight

out from the ends; with this method, all color bands are equal in width, and may or may not be touching each other.

Method II markings are identified by the fact that the color bands or colored areas are of different widths. This method is invariably used on resistors having leads coming out from the sides,

and sometimes also on end-lead resistors.

The tolerance marking, when present, indicates the amount by which the resistor may deviate from its rated value. Thus, a 100-ohm resistor with ± 5% (plus or minus five percent) tolerance may have an actual value up to 5 ohms higher or lower than 100 ohms (between 95 and 105 ohms).

Uninsulated resistors marked according to Method I have a black background color, while insulated resistors have a tan background color.

Missing color bands in Method I markings are assumed to be the background color (brown or black). A missing end color (B) or dot color (C) in Method II markings is assumed to be the same as the body color (A).

With Method I, band A is never black, for a resistor value cannot start with zero. When you encounter a resistor with a black band at the left end, it is either an uninsulated Method I resistor which you are trying to read backward, or it is a Method II resistor with the black band serving as end color B.

CONDENSER COLOR CODE. The basic scheme of the RMA Color Code is also used for designating values of fixed mica condensers. Three colored dots will usually be placed on the bakelite body of the condenser, along with an arrow or other markings which indicate the direction in which the dots are to be read. The value of the condenser in micro-microfarads is read in exactly the same way as for resistors; the first color dot gives the first figure in the condenser value; the second color dot gives the second figure; the third color dot gives the number of ciphers to be added to the first two figures.

TWO RESISTORS IN SERIES: TOTAL	$R = R_1 + R_2$	OHMS LAW FOR D.C., WHERE
	$R_1 \times R_2$	R IS RESISTANCE IN OHMS,
TWO RESISTORS IN PARALLEL: TOTAL	$R = \frac{R_1 \times R_2}{R_1 + R_2}$	E IS VOLTAGE IN VOLTS, I
	$C_1 \times C_2$	IS CURRENT IN AMPERES,
TWO CONDENSERS IN SERIES: TOTAL	$C = \frac{C_1 \times C_2}{C_1 + C_2}$	AND P IS POWER IN WATTS:
	$C_1 + C_2$	$E = I \times R$
TWO CONDENSERS IN PARALLEL: TOTAL	$C = C_1 + C_2$	$P = E \times I$
		$R = E \div I$
		$I = E \div R$
		$P = I^2 \times R$
		$P = E^2 \div R$

HOW TO READ SCHEMATIC DIAGRAMS

A SCHEMATIC circuit diagram is a symbolic means of showing electrical connections in radio apparatus. It tells very little about how the various parts look, how they are constructed, or where they are located on the chassis, but it does tell how the parts must be connected together electrically to make the set operate. The schematic diagram also provides a quick means for checking

connections during construction work and when hunting for defects in improperly operating apparatus.

A circuit diagram is read from left to right when tracing intelligence signals from the antenna to the loudspeaker. Look for the antenna or input terminals at the upper left, then move across the diagram one stage at a time. Usually the stages will be labelled to indicate their

functions, so the tube lineup of a receiver can be determined almost at a glance once a bit of experience is secured with these diagrams.

The power pack is always placed near the bottom of the diagram. It can readily be identified by the fact that it will have an input connection to a power line or storage battery. In battery-operated equipment, the circuit will usually show

HOW TO READ SCHEMATIC DIAGRAMS

only the terminals to which the A, B, and C batteries are to be connected.

The preliminary scanning of a complete diagram to "get your bearings" is about the only time when a schematic circuit diagram need be read completely all at once. The radio man is usually interested only in one particular section of the diagram, for he works on only one section of a receiver at a time.

One important fact to realize is that junctions of wires on a schematic may be arranged differently from corresponding terminals on actual apparatus. Thus, there may be two resistors and two condensers connected to a particular tube socket terminal on the chassis, but only a single line going to that same terminal on the schematic diagram; somewhere along the line, however, you will come to the symbols for these same resistors and condensers. A schematic diagram is drawn so it will be easy to trace through, while parts are arranged on a chassis so

connections will be easy to make, leads will be as short as possible, and parts which might interfere with each other are kept far apart.

The symbols used on schematic circuit diagrams to represent various radio parts are shown in the accompanying chart. When several different symbols for a particular part are in common use, these are shown. Variation in symbols are most evident in the case of radio tubes, but will give no difficulty once you learn that a dotted or zig-zag line always represents a grid, and a solid line, solid box or hollow box represents an anode.

In battery symbols, the short line is always negative or minus and the long line is positive or plus.

Several methods of showing cross-overs of wires are in common use, but there should be no confusion if you first look over a new diagram to see which method is employed. If a half-circle is used to bring one wire over another

when there is no connection, you can be sure that a connection is intended when wires cross without having this half-circle symbol. If there are no half circles anywhere on the diagram at cross-over points, and there are solid dots at some cross-overs but not all, then the solid dot indicates a connection and the plain cross-over indicates no connection. In any event, a solid dot at a junction will always indicate a connection.

Filament circuit connections are so standardized that a radio man seldom bothers to draw them in. Instead, he brings the two filament leads out of the tube symbol a short distance, labels one X, and labels the other Y. Corresponding letters will be found on the two leads of the filament winding in the power pack. This system of marking indicates that all points marked X are to be connected together and to the X terminal of the filament winding, and all points marked Y are to be connected to the Y terminal of the filament winding. The tube filaments are then connected in parallel, as is always done in a.c. receivers, and almost always in battery-operated sets.











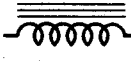





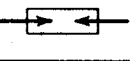

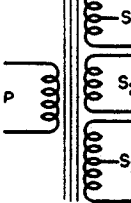
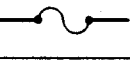
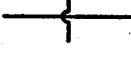
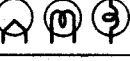
Sometimes a ground symbol will be used in place of Y, indicating that those terminals are simply connected to the nearest convenient chassis lug. Then again, the letter H will be used on all filament leads, indicating that all tube filaments and the filament transformer are to be connected in parallel, with polarity being unimportant.

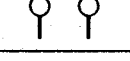
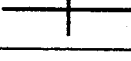
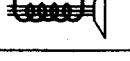
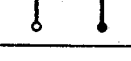
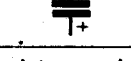
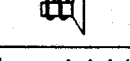
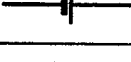
In universal a.c.-d.c. receivers, the filaments are invariably connected in series. Sometimes the connections are shown right on the schematic diagram, but usually the filament symbols will be omitted from the tube circles, and will be shown instead near the bottom of the diagram, all connected together as they should be. When you encounter this type of connection, be sure to follow the exact order of connections shown on the diagram. The filament of the power output tube and rectifier tube must often have particular positions in the line-up to give satisfactory operation.

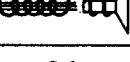
Other methods of showing series filament connections are generally self-explanatory once they are studied for a few minutes while keeping the above basic facts in mind.

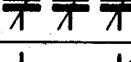
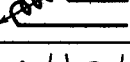
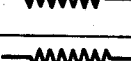
Connections to the chassis are usually indicated by a ground symbol. The chassis of a universal a.c.-d.c. receiver is seldom connected directly to an external ground.

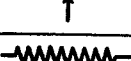
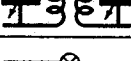
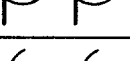
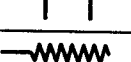
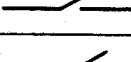
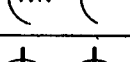
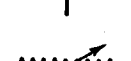
Bottom views of tube sockets, showing terminal connections, are usually given either directly on a schematic circuit diagram or on a separate diagram. However, schematically drawn tube terminal connections are not always drawn in the same rotation as the actual socket connections. If a separate diagram indicating the proper terminal number is not included, a tube chart or manual must be referred to. Always use the aligning key as your guide for locating a particular terminal when working with octal-base tubes. With older tube bases, the spacings between prongs are unequal to permit locating a particular prong. In some cases the spacing is equal but the filaments are indicated by larger socket holes. With this as a guide the other elements may be identified.

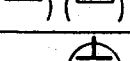
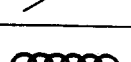
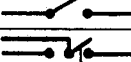
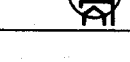
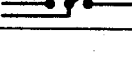
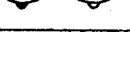
 ANTENNA (AERIAL)	 IRON-CORE CHOKE COIL	 SWITCH (ROTARY OR SELECTOR)
 GROUND (OR CHASSIS CONNECTION)	 R F TRANSFORMER (AIR CORE)	 CRYSTAL DETECTOR
 LOOP AERIAL (USUALLY BUILT INTO CABINET OF RECEIVER)	 A.F TRANSFORMER (IRON CORE)	 LIGHTNING ARRESTER
 CONNECTION	 POWER TRANSFORMER P: 115-VOLT PRIMARY S ₁ : CENTER-TAPPED SECONDARY FOR FILAMENTS OF SIGNAL CIRCUIT TUBES S ₂ : SECONDARY WINDING FOR RECTIFIER TUBE FILAMENT S ₃ : CENTER-TAPPED HIGH-VOLTAGE SECONDARY WINDING	 FUSE
 NO CONNECTION		 PILOT LAMP
 NO CONNECTION (WHEN CONNECTIONS ARE INDICATED BY DOTS)		 HEADPHONES
 CONNECTION (WHEN NO-CONNECTION CROSS-OVERS ARE INDICATED BY HALF-CIRCLES)		 FIXED CONDENSER (MICA OR PAPER)
 TERMINAL	 FIXED CONDENSER (ELECTROLYTIC)	 LOUDSPEAKER, P.M. DYNAMIC
 ONE CELL OR "A" BATTERY	 VARIABLE CONDENSER <small>ROTOR PLATES</small>	 LOUDSPEAKER, ELECTRODYNAMIC
 MULTI-CELL OR "B" BATTERY	 GANG TUNING CONDENSER	 PHONO PICK-UP.
 RESISTOR	 TRIMMER AND PADDER CONDENSER	 FILAMENT
 POTENTIOMETER	 I.F. TRANSFORMER (DOUBLE-TUNED)	 CATHODE
 TAPPED RESISTOR OR VOLTAGE DIVIDER	 POWER SWITCH (S.P.S.T.)	 GRID
 RHEOSTAT	 SWITCH (S.P.D.T.)	 PLATE
 AIR-CORE CHOKE COIL	 SWITCH (D.P.S.T.)	 3-ELEMENT VACUUM TUBE
	 SWITCH (D.P.D.T.)	 ALIGNING KEY OF OCTAL BASE

SPARE TIME JOB PLANS

HOME MODERNIZATION—Extra Outlets Illuminated House Numbers, New Modern Lighting Fixtures, Replacing Worn Appliance and Lamp Cords.

There is an old story which relates how a young son of a merchant set out to seek success and traveled over many lands WITHOUT finding it. After many years he came back home to find that his brother, who was much younger than he, had a very prosperous business and was a very successful man. The older son then asked his younger brother, "Brother, how came you to this great success—I've traveled many lands and haven't made any progress?" The younger son replied, "I merely made the most of the opportunities around me."

This story outlines a very IMPORTANT point. **Make the most of the opportunities around you.**

This Spare Time Job Lesson will outline many types of jobs that are available in almost every community. These jobs are waiting for SOMEONE to do them. A little initiative in going after these jobs will pay you BIG DIVIDENDS.

HOME MODERNIZATION

The rapid strides being made in the great field of Electric Illumination constantly opens up opportunities for modernization and improvement of lighting conditions, not only in the home, but also in the office, factory, theater, store, etc.

This tremendous field offers wonderful opportunities in almost every locality. Practically every building a few years old can be improved by installation of modern fixtures, and in many cases, especially in the older buildings, the lighting equipment is not only out of date, but it is very undesirable from the standpoint of efficiency, appearance, and decorative harmony.

CEILING FIXTURES

It is not usually a difficult task to replace old ceiling fixtures, that is, the work involved is not at all complicated for men who understand the material in this book.

Whenever possible the power should be shut off in the building by opening the switch or removing the fuses at the service box before the old fixture is removed, and after the new fixture is properly fastened to the fixture stud, the splices should be carefully made, soldered, and taped.

The correct fixture to select is governed by size and type of room, the decorative scheme, and the personal taste of the owner.

The first thing to do is to get some up-to-date catalogs on modern lighting fixtures.

BED ROOMS

In many cases, especially in some of the older homes, bedrooms were not considered such an important part of the home from a decorative standpoint. Therefore, many fixtures have been installed that do not make a desirable appearance. This fact makes many home owners prospects for some of the modern fixtures designed for use in bedrooms.

KITCHEN LIGHT

The kitchen is one of the most important rooms in the home from the standpoint of good lighting, but there are many homes where just an ordinary drop light is used. A very good type fixture for use in the kitchen is the new fluorescent types or one with a direct diffusing bowl with a 100-Watt lamp or larger, depending on the size of the kitchen. In large kitchens it is also desirable to have wall lights mounted above the work table or range.

BATH ROOM

The new tubular shaped "lumiline" lamps are ideal for use in bath rooms. One lamp may be mounted on each side of the mirror. This arrangement gives sufficient general lumination for the bath room and has the added advantage of supplying ideal light on the face so that there are no shadows on the face when the mirror is used.

ILLUMINATED DOOR NUMBERS

How many times have you had difficulty in locating a certain house on a dark street? Needless to say, almost everyone has had this difficulty because, very few houses are illuminated at night so that the door number can be seen from the sidewalk or the street. This difficulty can be eliminated by leaving a bright light burning at the entrance to the house, but in most cases the light that is used to light up the entrance is of high enough wattage so that it is too costly to be left on during late hours of the

night. Therefore, almost every home owner is a good prospect for a good illuminated door number that can be operated at a low cost.

REPLACE DEFECTIVE LAMP AND APPLIANCE CORDS

There are thousands of homes with worn, frayed, defective and dangerous lamp and appliance cords that need replacing. New cords can be easily made up from colored rubber-covered zip cord wire. Many homes have defective toasters, flatirons, portable electric heaters, etc., that can be quickly and economically repaired by replacing the old burned-out heating elements cords or switches.

Electric fans, vacuum cleaners, washing machines, refrigerators, food mixers, etc., all have motors and switches that get out of order. Very often these defects are so simple to remedy that 10 minutes' to one hour's time is all that is required to give them a good cleaning, replace motor brushes, adjust brush

spring tension, clean commutator, resolder a broken wire or lead, and put them back in good condition.

In addition to these opportunities, there are also thousands of old homes with a shortage of convenient outlets, resulting in long, unsightly, unsafe extension cords running all over the rooms.

It is a simple and inexpensive job to install and connect additional outlets on the baseboards or walls of such houses. This means greatly improved convenience for the owner and a nice profit for the installer. New and improved outlets will greatly decrease fire hazard and eliminate the possibility of shocks or burns to children. This is a strong selling point to put over in presenting this service to a home owner.

So, go out after this work, and in a very short time you may find you have built up a reputation and a full-time electrical business, just as many other men have done.

SPARE TIME JOB PLANS

ELECTRICAL ADVERTISING DEVICES

There is a big field in almost any town for electrical advertising devices. I have reference to devices such as the JUMPING RING—the LADDER ARC, the SHOE-STRING LAMP, etc. These are novelties that attract attention. When placed in the window of a store or shop, they will make people STOP AND LOOK. If you can get people to stop and look, there is a chance that you might get them to come in and LISTEN to you on what you have to sell.

Many men are making good money building these interesting displays and either SELLING or RENTING them to store owners in their locality. This novelty electrical display advertising is a new idea for many communities and can be used for most any type of store.

The following diagrams, technical wiring information and a little experimenting should enable you to construct your own units at very little cost. After you have a few devices built, take them out and demonstrate them to various shop owners. Work out some plan of rental or outright sale of the devices and you may find that you have a very good sideline for increased revenue. Working out this plan in your locality is just another way to make use of this Coyne Trouble Shooting Manual. We don't recommend that you leave your job to promote this plan but we offer it to you as a means of using your SPARE TIME to the best advantage.

Here is the information for several interesting electrical displays:

JUMPING RING

The jumping ring should be mounted in a wooden box in such a manner that the transformer core and coil, switch and connections are below the top of the box, in order to conceal these parts. An intermittently-operated switch may be connected in series with the coil to provide repeating operation.

When the circuit is closed, the ring will be forcefully repelled by reason of heavy currents induced in it due to transformer action when the coil is energized. The circuit should remain closed for a few seconds, causing the ring to remain suspended without any apparent reason. It is this evident

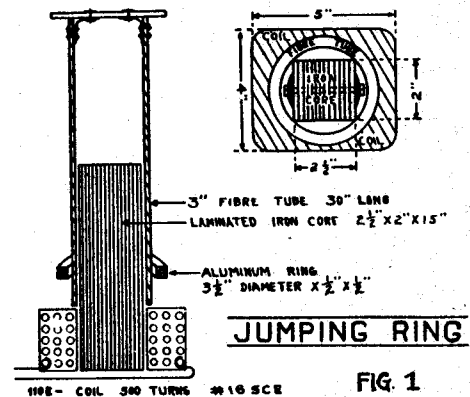

defiance of the law of gravitation which arouses the interest of a passer-by.

LADDER ARC

The ladder arc operates on the principle that electric arcs drawn in air between vertical wires will be driven upward by the rising heated air and by magnetic action. In the arrangement shown, the arc is first formed at the bottom of the tube and travels rapidly to the top where the increasing arc length and resistance finally causes it to snap out. When this occurs, the arc is immediately re-established at the base and the cycle is repeated. Location of this device in a manner that will permit free circulation of air through the tube will result in improved operation by increasing the rate at which the arc travels.

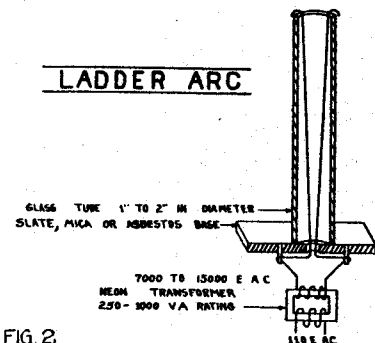

FIG 2

The size of the transformer to be used with this device can be determined by experiment; however,

a 1000 VA (9000V) neon sign transformer will operate quite satisfactorily on a tube two inches in diameter. If a one-inch tube is used, a 300 to 500 VA transformer will be satisfactory. If the wires expand enough when heated to interfere with operation, a small coil spring may be inserted in each wire at the top to take up the extra length caused by expansion.

THE DIVING DUCK

Another "attention-getter" is the Electric "Diving" Duck. This device is very inexpensive to construct and consists of a SMALL glass fish bowl half filled with water, with a small celluloid duck, a 2"x4" iron core with 500 turns of No. 14 SCE wire and an old automobile battery.

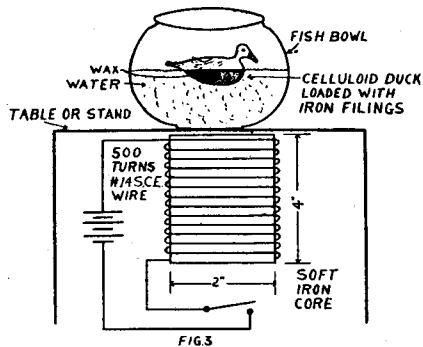

The fish bowl is set on a small table, the duck is filled part way with iron filings so that it will barely float. This can be done by slitting the front portion of the duck, pouring in the necessary filings and then sealing the opening with hot sealing wax. The magnet is connected to the battery and either an automatic timing switch or a manually operated hand switch inserted. When the switch is on, the duck dives; when it is released, it floats back to the top.

LIGHTING WITH SHOE STRINGS

Another simple, yet effective, attention-attracting device may be constructed from an ordinary ten-watt lamp and a shoestring. Two No. 30 plain enameled wires are soldered to the lamp terminals, care being taken to make the connection as inconspicuous as possible. The connection to the screw shell may be imbedded in the sealing compound and brought out close to the other wire. The two wires are then fed through a hollow shoelace, one end of which is tied around the screw shell while the other is fastened to a suitable support that has been drilled to permit passage of rubber-

covered concealed wires through it to the point of supply.

Effectively constructed, this exhibit readily intrigues the passer-by because it presents the unreasonable picture of an apparently unenergized lamp glowing at the end of ordinary shoestring.

Caution should be exercised to avoid short circuits between the enameled wires in the string. It is advisable to separately fuse the cord leading to this device, with a fuse of five amperes or lower capacity.

ANOTHER INTERESTING LIGHTING DISPLAY

Here is another inexpensive lighting display that attracts attention. In No. 4 you have a piece of heavy plate glass two feet square. The glass is supported by two 2"x6" wood blocks and another block of wood 2"x4" is set on the top of the sheet of glass with a socket for the 10-watt lamp. Wires are run from this wood block, shellacked to the sides of the glass into the wood blocks at the base. From there they lead to the outlet. The wire to be used is green silk No. 40 wire and care should be exercised to see that the wire is solidly shellacked to the sides. This display gives the illusion of an electric light operating without wires.

On any of these displays, it might be well to insert a flasher button so the device is in constant operation at all times. This would make it attract more attention and add to its advertising value.

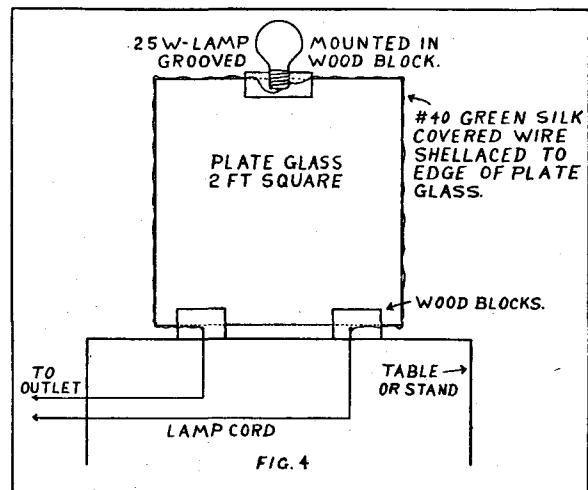

This electrical advertising display plan is a good money-maker for you, so get busy on your displays as soon as you can and sound out the possibilities in your locality.

SPARE TIME JOB PLANS

MAINTENANCE CONTRACTING OFFERS BIG OPPORTUNITY

One branch of the electric trade in which many opportunities exist throughout the country today is **MAINTENANCE CONTRACTING**. There are opportunities in this field that are almost completely overlooked in many localities, and going begging for want of some competent maintenance electrician to capitalize them.

For example, there are thousands of small shops, factories, stores, offices and hotels that really cannot afford to employ a full-time salaried maintenance electrician, because they do not have enough of such work to keep a man busy full time. Nevertheless, the electrical equipment in these places needs certain care and repair which is often seriously neglected because its owner puts off until the last possible moment the calling of a service electrician, or sending out of equipment to the repair shop.

REGULAR MAINTENANCE SAVES MONEY

In many such places motors are allowed to run overloaded, on undervoltage, poorly lubricated at the bearings and with oil soaked and dust clogged windings, until they burn out and cause expensive shut downs and delays within a small fraction of the time their useful life should be if they were given proper inspection and care. Low power factor accounts for many more burnouts and losses.

Lights are allowed to operate with old, inefficient bulbs in which the filament is nearly burned away and the interior of the bulb is coated nearly black, to say nothing of dirty fixtures and reflectors and low voltage on the lighting circuits, all of which may reduce the efficiency of the lighting equipment to little more than half of its original value.

In still other cases wiring has been allowed to deteriorate until the insulation is rotten and leaky, with circuits badly overloaded and sloppy dangerous temporary wiring creating fire and shock hazards and continuous losses due to voltage drop and grounds. In the majority of such cases these conditions could be prevented or remedied by a small amount of attention from an intelligent and competent maintenance electrician at much less cost to the equipment owner than he is wasting otherwise in

excessive power bills, unnecessary shut-downs and expensive repair bills.

If more men in the neighborhood of these places would offer their services on a **part-time basis** to several such employers many of them would find very profitable employment. This not only applies to independent individual electricians, but to many of the established electrical service shops and contractors which are not giving these small maintenance jobs the attention they deserve.

However, the independent electrician who can go from plant to plant with a moderate kit of tools, can often provide this preventive maintenance service at lower cost than some of the repair shops because of his lower overhead. Many equipment owners are quite willing to have **modern inspection and maintenance service** for their equipment when shown the saving that it can effect, and the small monthly cost at which it can be obtained.

An electrician may line up five, ten, twenty or more small plants. Some on written contracts and others on verbal agreement during a trial period. Some places may require only a few hours of his time each month to inspect, test, and clean a few motors, controls, and lights. Others may require several days per month to properly inspect, test and repair a larger group of machines and lights. Five or twenty-five dollars per month is not a very large amount for many shops to pay for this service even though their equipment may not justify paying a steady electrician a full monthly salary. However, it does not require many places at \$5, \$10, \$20, or \$30, per month to make a nice extra income for a part-time maintenance contractor.

UNLIMITED FIELD FOR SERVICE

Some equipment owners when offered such a service reply that they can't afford it even at \$5.00 per month, as their electrical repair bills have not averaged that amount so far. What these men are generally overlooking is the much heavier repair bills they are certain to have a little later when their machines start to burn out and fail in less than one-fourth their normal life, because of the neglect on repairing small things before they become serious

breakdowns. Regular inspection, cleaning, insulation testing, bearing lubrication, brush and commutator repairs, etc., can save much of this trouble and prolong the life of this equipment many years.

If large factories and plants find it profitable to maintain crews ranging from several dozen to several hundred electricians to provide this modern preventive maintenance service, then why can't the smaller shop owner profit by it on a smaller scale?

For a concrete example, we know of one recent case in which a man, out looking for a job, offered his services part-time to a plant owner, who had emphatically said he did not need an electrician. Starting out at a few hours per week, this man showed such savings and improvements on the electrical equipment he maintained and repaired, that within a few weeks it developed into a full-time maintenance job. It was found that this plant was having quite frequent burn-outs of their motors due to overloading, low line voltage, poor power factor, defective controller contacts and protective devices, improper fusing, etc. After a brief study of this condition by the writer who acted in a consulting capacity to the maintenance electrician, savings were effected in the repair bills and production delays that far more than paid the electrician's salary.

In another instance a man offered this class of maintenance service to a small plant owner and made a few inspections and minor repairs when he was asked to rewind the armature of a burned-out 5 h.p. D.C. motor. After satisfactorily completing this job at very reasonable cost to the owner and a fair profit to himself, he was promptly shown several dozen burned-out machines of similar and larger size which had been held in a storeroom unrepaired, because this owner had received one or two exorbitant estimates on rewinding them at outside shops. This resulted in a steady job for this man.

SMALL CAPITAL NEEDED TO START

A wide variety of similar opportunities in maintenance contracting are open to the maintenance electrician who has a thorough knowledge of electrical machinery operation and trouble, modern maintenance methods, the use of simple test instruments, and a little ability to sell this money saving service to many plant and equipment owners who have not yet had it properly presented to them. Much of this class of maintenance work can be done with only a very moderate investment in tools and test equipment and handled in your spare time.

ADD AN EXTRA SPEAKER PLAN

Here is a Sales idea for Radio men that is proving very successful in all parts of the country. It is this Add an Extra Speaker Plan. Briefly, here is the idea:

Many homes today have just one radio. This radio is in the living room and unless the volume is turned up considerably the radio can only be heard in that room. Many folks would like a radio in the kitchen, bedroom, on the back or front porch or down in the game room in the basement, but the cost of buying a separate radio for these rooms is prohibitive in most cases. Here is where you have a chance to satisfy this desire for an extra Radio by selling the **Add An Extra Speaker Plan**.

Here is what you should do if you are interested in working this plan in your city or town. First of all, refer to diagram in the Radio Section of this manual covering the installation. This will give you complete wiring instructions for these extra speakers.

SPARE TIME JOB PLANS

PROPER TREATMENT FOR WATER-SOAKED ELECTRICAL MACHINERY

A good electrician should be able to properly meet all conditions that arise which interfere with the operation of electrical machines. Machines are sometimes exposed to excessive moisture or flood waters because it is often necessary to install them in basements, mines and other damp places, or where flood waters may reach them. Machines that are used for under-ground work, such as in mines, tunnels, etc., become saturated with moisture when they are not operated for a long period of time. These machines as well as machines that have been covered by flood water must be thoroughly dried out before being put in regular service. So in many cases a thorough understanding of how to correctly treat water-soaked machines will be very valuable. Much of this work has been made necessary by floods, and very often machines that have been water-soaked or allowed to absorb moisture while idle, must be dried out.

The machine should first be thoroughly cleaned before drying. If the machine has not been covered with flood water, the cleaning will not be so difficult. All the surface moisture should be wiped off with a rag or waste to expedite the drying out process. If the machine has been covered with flood water then the windings may be filled with sand, mud, silt, etc., and must be put through a thorough cleaning process before drying. If the machine is covered with mud it can be washed off with a strong jet of water from a hose, being careful not to use high enough pressure to damage the winding insulation.

Solutions commonly used for final cleaning and removal of grease, are kerosene, gasoline, and carbon tetrachloride. Kerosene and gasoline are cheaper but are very dangerous to use around open fires, as even the fumes or vapors from these liquids are very explosive. Carbon tetrachloride is the safest cleaning agent to use as it is non-inflammable but the cost of this agent prohibits its use where economy is a major item. Kerosene can be used very successfully if the proper precaution is used to prevent fire. A very high grade of kerosene should be used so it will evaporate rapidly after the machine has been cleaned. When using kerosene, or gasoline for cleaning, ample time should be allowed for complete evaporation before exposing the machines

to high temperature or placing them in operation.

A convenient cleaning process for small machines and machines that can be easily disassembled, is to fill a pan or vat of the proper size with the cleaning agent and place the machine or windings in the vat and use a stiff brush and wash the windings until clean. Machines that are too large for their parts to be placed in a vat can be cleaned by first carefully scraping or cleaning with a thin wooden stick or paddle having smooth edges. Then compressed air or a spray of kerosene can be used to finish the cleaning job. Slender bottle brushes are very handy for cleaning dirt out of ventilating slots and other small places.

METHODS FOR DRYING OUT MACHINES

1. Place the machine or its parts in an oven and bake at the proper temperature until dry.
2. Send current at reduced voltage through the windings until the internal heat produced dries the machine.
3. Cover the machine with canvas, or other material) to enclose it and place a heating unit under the enclosure, using a fan to circulate the heated air.

The proper method to use will be governed by the size of the machine and the equipment available to do the work. Fractional H.P. machines and machine parts that can be placed in an oven can be completely dried out in a few hours. The time required for drying will vary according to the size of machine or winding. The following chart gives approximate time for baking machines of different sizes, at 185° F. This temperature should not be exceeded on wet machines using cotton enamel and paper insulations. Temperatures up to 205° F. can be used on machines with mica insulation.

Core Diameter	Temperature	Time
Under 6 inches	185° F.	4 to 6 hours
6 to 12 inches	185° F.	12 hours
12 to 18 inches	185° F.	24 hours
18 to 24 inches	185° F.	36 hours

The following drawing shows how electric heating units and an electric fan may be used for circulating warm air through a temporary oven.

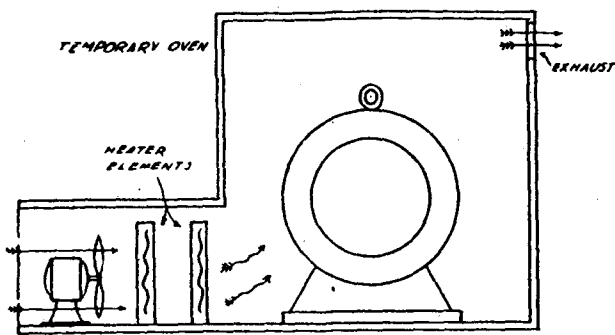

If, in emergencies, a higher temperature is used, the drying can be done quicker, but the temperature should not be high enough to damage the insulation.

The oven used does not have to be specially built, in fact, the oven in the kitchen stove can be used very satisfactorily for small machines and windings. Very often a crude oven or box made of bricks or sheet iron will serve the purpose. If the oven is not equipped with a thermometer, one should be placed inside the oven to eliminate guess work.

Machines that are too large for oven drying can be dried out by placing them in operation, using proper precaution to prevent damaging the machine. When this method is used, the first thing to do is disconnect all load from the machine and separately control the current through each winding. The current used to dry out the machine should not exceed normal operating current. A very low voltage should be applied to the machine at first as its resistance will be very low, and probably it will not rotate at all until partially dried out. On large high voltage machines the voltage applied for drying should not exceed 15% of normal operating voltage. On smaller machines not over 25% of normal voltage, or the insulation may be punctured and burned by excessive leakage current. After the machine starts rotating and has partially dried, the voltage applied can be gradually increased to keep enough current going through the windings to produce heat for drying. Do not put any load on the machine until it has operated for some time with normal operating voltage applied to the windings, then add the load very cautiously and if any part of the machine starts overheating the power should be disconnected and that part of the machine properly protected before proceeding with the operation. When using this method on badly soaked large machines it may require days of drying out before the machine can be put in regular service.

When a very large machine is water soaked to a point where it would be dangerous to connect power to it, a canvas or other form of enclosure can be built around it to serve as an oven. Steam, gas or electrical heating units can be used to provide the heat. A fan should be used to circulate the heated air, through the machine, to carry away the moisture and to promote thorough, even drying. The enclosure should be constructed so there will be an opening on each side of the machine. The fan should be placed in one opening and the air pulled in

from the outside and blown past the heating units, then through the machine, and out on the opposite side. A thermometer should be placed on the machine winding to check the temperature, which should be kept at the proper value.

If a megger, or other instrument used to test insulation, is available the insulation should be tested to determine when its resistance has again reached a safe value. If test instruments are not available, then the machine should be observed closely for several hours after it has been put in operation, and if any part of the machine starts overheating, it should be shut down and the drying out process continued until the trouble is eliminated. If the insulation has been damaged by cleaning or drying it should be coated or dipped in baking varnish and rebaked. If it is not possible to bake the insulating varnish, then use air drying varnish. This will greatly improve the insulating qualities and increase the length of time that the machine will give satisfactory service.

When machines have been covered with flood water all other parts of the machine must be properly treated. Parts such as brushes, leads, tension springs, commutator and bearings can be washed with kerosene. Brushes should be cleaned and properly fitted to commutator, tension springs should be checked for proper brush tension, leads cleaned and dried or replaced with new ones, commutator washed and checked for roughness and high mica also well cleaned between commutator segments to prevent a flash over and shorted coils. It is often necessary on large machines with hollow commutators to remove several of the "V" ring bolts to drain out water that may have become trapped inside the commutator.

Bearings should be flushed with kerosene and new oil put in the bearings and the machine run for a short time; then drain the oil and refill. The reason for draining the first oil put in is that the kerosene left in the bearing after flushing will thin the oil and partially destroy its lubricating qualities. On large machine it is best to disassemble the bearings and wipe them out thoroughly.

A machine that has been water soaked should be dried out and re-insulated as soon as possible to prevent the moisture from rotting the insulation.

Always inspect all fibre and wood slot wedges and replace any that are warped or damaged. Rotor band wires should be inspected and tightened if necessary, because the rotor insulation sometimes shrinks a little after being dried out.

Emergencies often arise whereby it is necessary to dry out water soaked or damp electrical equipment, and the maintenance electrician who is qualified to take care of these emergencies is the man of greatest value to his employer. Such emergencies are also opportunities for trained men to increase their earnings by increased work in a business of their own. So be alert at all times and be ready to grasp these opportunities along with the many others in the broad field of electricity.

SPARE TIME JOB PLANS

FREE ELECTRIC POWER FROM WIND-DRIVEN POWER PLANTS

Among the various forms of energy available for use in generating electric power, "Wind power" may be classed with "Water power" as one of nature's greatest forms of free power. Wind power, although not as dependable as water power, may be used to good advantage in many parts of the country where water power is not available, and where it is inconvenient or too expensive to generate power by means of engine driven generators.

Small 6-volt plants for charging Radio batteries and for supplying lights in farm homes have become very popular in many parts of the country. It is no longer necessary to purchase and renew Radio "B" batteries since the development of the vibrator type "B" eliminator, which obtains its power from a 6-volt storage battery. However, in order to satisfactorily use a storage battery, some desirable means of recharging is necessary.

Naturally, all automobiles are equipped with generators designed for charging the automobile battery, and for that reason many such generators are available for use in wind-driven plants.

This job sheet is intended mainly for the man who wishes to build his own wind charger for the pleasure and experience to be gained from such work, and not with the idea that it should replace some of the very fine factory made plants now available at reasonable cost.

The main purpose of this job sheet is to point out some of the important requirements and then with your own creative ability you may construct your own plants.

GENERATOR SPEEDS

The average automobile generator is designed to operate at speeds from 800 to 2500 R.P.M., with best charging rate at speeds between 1500 and 1800 R.P.M.

The above speeds are considerably higher than the average speed obtainable from efficient wind wheels. The average speed developed by these wheels or propellers will be between 200 and 400 R.P.M. Therefore, if the auto generator is to be used, IT MUST EITHER BE GEARED UP BY MEANS OF GEAR, OR PULLEY ARRANGE-

MENT, OR THE GENERATOR MUST BE REWOUND FOR OPERATION AT LOWER SPEEDS.

PULLEY SIZES

The size of pulleys necessary for indirect drive, may be found by the following formula.

$$D.D.P. = \frac{D.G.P. \times R.G.P.}{R.D.P.}$$

In which

D.D.P. = Diameter of driving pulley.

D.G.P. = Diameter of generator pulley.

R.G.P. = Revolutions per minute of generator pulley.

R.D.P. = Revolutions per minute of driving pulley.

As an example, let us assume that on a certain generator, we have a pulley with a diameter of 2" to be driven at a speed of 1500 R.P.M. Assuming the speed of the propeller shaft to be 400 R.P.M., we apply the formula as follows:—

$$\frac{2" \times 1500}{400} = 7\frac{1}{2}$$

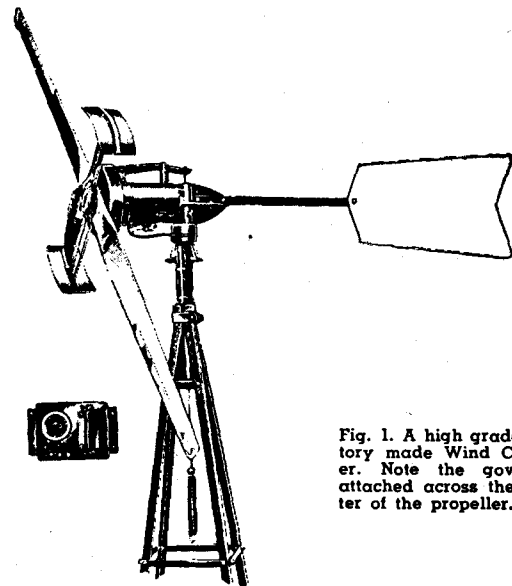

Fig. 1. A high grade factory made Wind Charger. Note the governor attached across the center of the propeller.

Therefore the size of the pulley necessary on the propeller shaft will be $7\frac{1}{2}$ " in diameter in order to drive the generator at a speed of 1500 R.P.M. This same formula can be applied to gears if they are used.

DIRECT DRIVE

The direct drive method is in most cases more popular than the pulley drive method. By direct drive we mean that the propeller is mounted

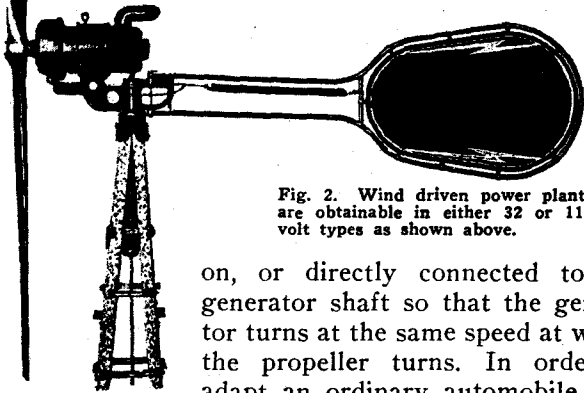

Fig. 2. Wind driven power plants are obtainable in either 32 or 110 volt types as shown above.

on, or directly connected to the generator shaft so that the generator turns at the same speed at which the propeller turns. In order to adapt an ordinary automobile generator for operation at slower speeds, the generator must be rewound.

REWINDING DATA

Since we know that the voltage output of a generator is governed by the strength of the field, the number of turns of wire on the armature, and

As an example, one of the model T Ford armatures has an original winding of 10 turns per coil of No. 17 S.C.E. wire. If we double the number of turns, the armature will be rewound with 20 turns per coil. Number 17 wire has a C.M. area of 2,048. One-half 2,048 is 1,024. We find in referring to a wire chart, that No. 20 wire has a C.M. area of 1,022 which is close enough. So the armature would be rewound with 20 turns per coil of No. 20 S.C.E. wire.

PROPELLERS

Factory made propellers designed for use on wind driven power plants are available in different sizes and styles. However, those who wish to build their own propeller may do so by following the sketches shown in Fig. 3.

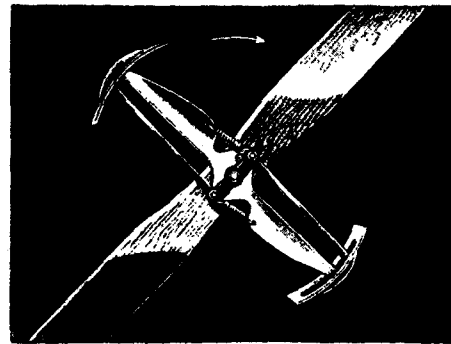

Fig. 4. The centrifugal air brake governor. Note how the springs are mounted to allow the governor to open in high winds.

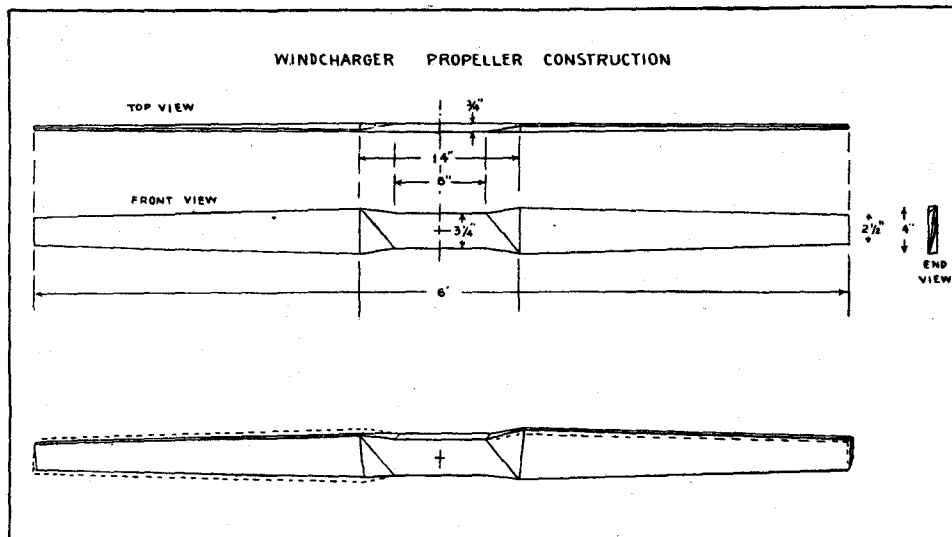

Fig. 3. The above sketch shows how a propeller may be constructed from a 1 x 4 board.

the speed at which the armature is rotated, we can easily understand that to obtain the same voltage at lower speed and the same field strength, we must increase the number of turns of wire on the armature.

The change which in most cases works out satisfactorily, is to double the number of turns on the armature, but it will also be necessary to decrease the size of the wire to $\frac{1}{2}$ the original circular mil area, in order to have room in the slots for the increased number of turns.

The board used for this purpose may be any good grade pine, cypress, or cedar board, 1" thick by 4" wide by 6 ft. long. After the propeller is properly shaped and balanced, it should be shellacked and

GOVERNOR

All wind driven generators should be equipped with a governor of some kind to prevent excessive speed in strong winds. A very popular type used on some factory made systems is shown in Fig. 4. This governor opens up at high speed and brakes up the

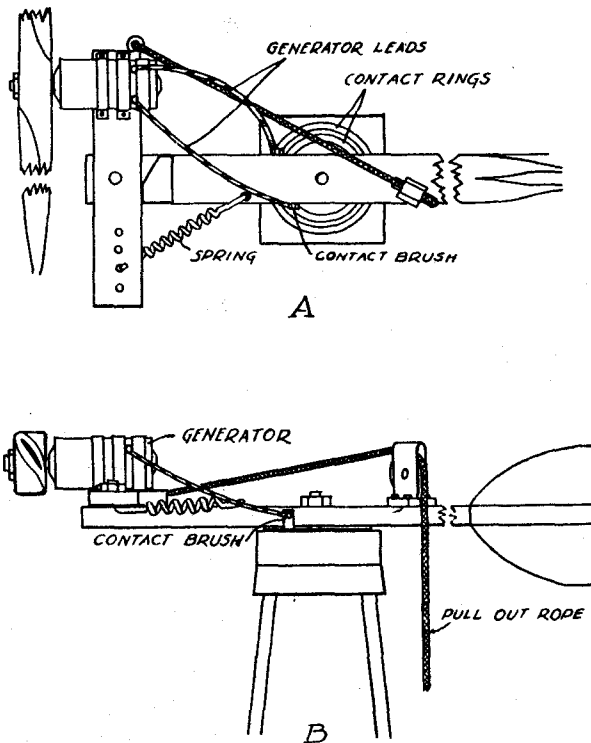

Fig. 5. A—Top view of offset type wind charger. B—Side view of same charger.

smooth air flow over the propeller, thereby holding down the speed. Another method which may be used is to off-set the mounting of the propeller shaft so that it will turn the propeller blades at an angle with the wind when the wind reaches a certain speed. Fig. 5 shows one method by which this may be accomplished. The tail piece tends to hold the generator and assembly directly into the wind, but when the wind becomes strong enough, the blades will be forced to turn at an angle against the spring tension. The spring tension may be adjusted to allow the governor to operate at any desired wind speed.

WIRING

It is very important that the wire used for the electrical circuit between the generator and the battery be of sufficient size to prevent excessive voltage drop. Wire not smaller than No. 8 B & S gauge should be used, and if the distance between the generator and battery is greater than 50 ft., it is advisable to use No. 6 wire or even No. 4 is still better.

It is also very important to use a relay to open the circuit when the propeller speed drops low

enough that the generator no longer generates sufficient voltage to charge the battery. In case a relay is not used, the battery will drive the generator as a

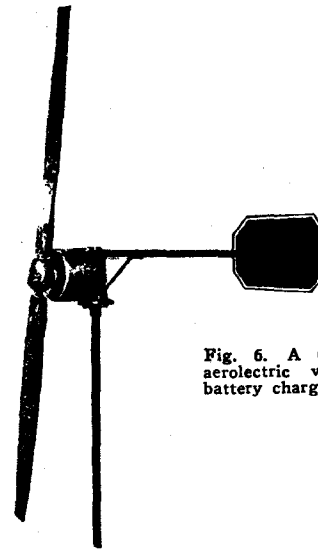

Fig. 6. A 6 volt type aeroelectric wind driven battery charger.

motor, and soon become discharged. The regular cut-out relay used in connection with the auto generator should work satisfactorily.

TOWERS

The wind driven generator must be mounted high enough so that the wind will have a free sweep to the propeller. Many installations are made on top of a building, and this method is satisfactory unless there are trees or some other obstruction in the way.

In cases where it is necessary to mount the generator still higher, a tower such as a regular wind mill tower may be used, or a straight pole similar to a telephone pole may be erected and properly guyed with wire in order to hold it from swaying in the wind.

A turn table is also necessary in order that the generator may turn so that the propeller faces into the wind.

Sliding contacts must be arranged so that the wire connections between the generator and the battery are not twisted off as the generator rotates on the turn table.

Building a WIND DRIVEN power plant is both interesting and educational. Whether you live in the city or in a rural section you could make use of a good wind driven power plant. With this information you should be able to easily build one of these units at very little cost.

SPARE TIME JOB PLANS

ELECTRIC WELDING OFFERS OPPORTUNITY FOR FULL TIME OR SPARE TIME JOBS

The purpose of this job sheet is to acquaint you with arc welding equipment, and enough of the principles and methods to enable you to start practicing simple welding operations.

If you practice these operations until you develop ability to make simple welds, this may provide an opportunity for you to make money repairing broken metal objects, or assembling metal parts by means of arc welding.

Among the many uses we have for electricity today, Electric arc-welding may be classed as one of the most important. Electric welding is being used more and more each day, and it is rapidly replacing older methods of welding.

In addition to arc welding, we also have Electric spot welding and butt welding. All methods are valuable for various uses, but arc welding is generally used for erecting steel buildings, constructing heavy machinery, and repairing broken metal parts.

WELDING POWER

Direct current has been generally accepted as better than alternating current for welding purposes. However, A. C. may also be used quite satisfactorily.

The voltage required for welding may vary between 20 and 60 volts with an average between 30 and 40 volts. The current will vary from a minimum of 25 amperes to 600 amperes or more.

The welding arc is drawn between the metal to be welded, and a metal electrode, or between the metal and a carbon electrode. When a metal rod is used the process is called **METALLIC ARC WELDING**. When a carbon or graphite rod is used for one terminal of the arc the process is known as **CARBON ARC WELDING**.

For "metallic arc welding" work the electrode is simply a metal wire or rod. This rod supplies the filler metal as the weld is being made. Therefore, the rod must be renewed from time to time as the weld progresses. When an arc is struck between the work and the metal electrode tremendous heat is generated which will fuse both the metal to be welded and the tip of the electrode. Metal is carried from the electrode to the metal to flow from the electrode to the work, it is possible to perform a

weld with the welding surface in a flat, vertical, or overhead position. In fact, the "metal arc welding" method is the only method by which metal may be successfully deposited overhead.

When using the method known as "carbon arc welding" the electrode consists of a graphite or carbon pencil. This method requires that a metal filler rod be supplied to the arc as the weld progresses.

The metallic electrode method is more extensively used because the metal deposited is more likely to be homogeneous or uniform and the appearance of the weld is smoother and more desirable.

The carbon arc method may be used for making welds where appearance is not important, but probably the greatest use for the carbon arc is cutting or melting away excess metal.

THE WELDING ARC

As previously explained, the arc may be formed with either alternating current or direct current, but D. C. is the more desirable form of current.

When using A. C. there is no difference which lead from the power is connected to the electrode, since the electrode will be negative half of the time and positive the other half of the time.

When using D. C. the positive lead from the power is usually connected to the metal being welded, and the negative lead is connected to the welding electrode. However, in case very thin metal

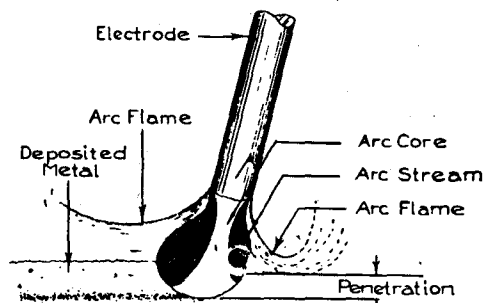

Fig. 1. Diagram of the welding arc.

is being welded it is sometimes desirable to reverse the connections and make the welding electrode positive.

Practice seems to indicate that there is a greater amount of heat concentrated on the metal connected to the positive line and since more heat is required on the heavy metal being welded it is desirable to make the welding surface positive. The electrode is usually small compared to the welding surface, therefore the smaller amount of heat at the negative terminal is a desirable feature, unless the metal to be welded is very thin. In case the metal to be welded is very thin there is less danger of the arc burning through the metal when the electrode is positive.

ARC CHARACTERISTICS

The various characteristics of the arc may be observed by using suitable darkened glass. IT IS VERY IMPORTANT NOT TO LOOK DIRECTLY AT THE ARC WITHOUT PROTECTION TO THE EYES BECAUSE the light given off by the arc is so intense that it causes a severe reaction and the eyes may become very painful and vision difficult. The fact that this reaction does not set in immediately is even more dangerous because an individual who is not familiar with the effects of the arc may look at the arc repeatedly, not realizing the damage that is being done. Several hours later the trouble begins and although the eyes will respond to treatment and gradually come back to normal, it certainly is advisable to not take chances of damaging them. ALWAYS USE DARKENED GLASS WHEN WELDING OR AT ANY OTHER TIME WHEN OBSERVING AN ARC.

When using a suitable shield the arc may be viewed and it will appear something like the drawing shown by Fig. 1.

ARC LENGTH

It is difficult to follow any set rule regarding the length of the welding arc, but as a general rule when welding with the metallic electrode the arc should be held as short as possible without causing the electrode to touch the work and put out the arc. This length may vary anywhere between 1/16 of an inch or less to 1/4 of an inch, depending on the diameter of the electrode and the amount of current used.

The length of the arc when using the carbon electrode may vary between 1/4 and 1 1/2 inches.

WELDING CABLE TERMINALS

During the welding process the positive line lead must in some way be connected to the metal to be

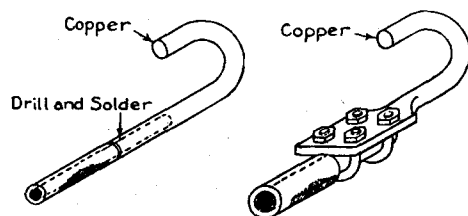

Fig. 2. Heavy copper hooks as shown above may be attached to the welding cable for convenience in attaching the cable to the welding work.

welded. This may be accomplished by clamping the cable to the metal, or a heavy copper hook as shown

by Fig. 2 may be attached to the cable for use in making connection to the metal to be welded.

An electrode holder must be attached to the other cable to provide a convenient means of attaching the welding electrode, and to enable the operator to conveniently handle the electrode.

An electrode holder for light welding may also be constructed quite easily from a brass tube about 12 inches long. The inside diameter of the tube should be about 1/8 inch so that it may be threaded to take a thumb screw. A hole is drilled through the tube about 1/2 inch from the end so that the welding rod may be inserted. The thumb screw is then turned into the end of the rod until it makes contact with the welding rod so as to hold the welding rod firmly

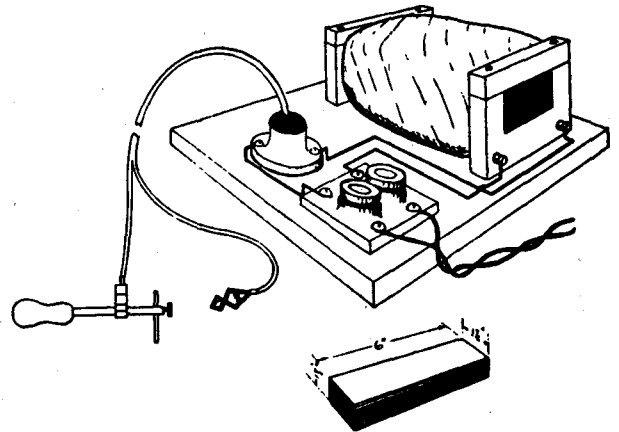

Fig. 3. The above diagram shows one method which may be used in mounting a reactance coil connected for use as a low power welder.

in place. A handle is then placed on the brass rod and the electrode holder is ready for use. The welding cable may be attached by means of a heavy clip.

WELDING EQUIPMENT

An inexpensive welder may be constructed for operation on 110 volts A. C. as shown by Fig. 3. This welder although not large enough for heavy work may be used for soldering, light brazing, or welding.

This welder consists of a reactance coil which serves the purpose of reducing the line voltage something like a resistance unit, but it has the advantage of helping to stabilize the arc.

The core for the reactance coil is constructed from strips of transformer iron. Strips 1 1/2" x 6" are stacked 1 1/2" high, so as to form a core 1 1/2" x 1 1/2" x 6". This gives a core area of 2 1/4". The core may also be constructed of strips of different widths, as long as the approximate area of 2 1/4" is maintained. As an example, strips 1" wide may be used by stacking them 2 1/4" high, or strips 2" wide will give the proper area when stacked 1 1/8" high.

The core should be equipped with end collars of insulating material such as fibre or wood. The core is then ready to be wound with the proper amount of insulated wire. For this purpose about 225 turns of No. 12 D. C. C. or larger wire, works very nicely. The coil should be carefully wound in neat even

layers so that the turns do not criss-cross one another.

After the coil is completed, it should be mounted on a supporting base and equipped with fuses and flexible leads as shown by Fig. 3.

When using coil for welding purposes, it is simply connected in series with one side of the line and connected to the electrode holder. The other side of the line is connected to the metal to be welded.

GENERAL WELDING INSTRUCTIONS

There are a few fundamental principles which one should understand in order to do successful welding, and if you understand these principles, then the speed and finer skill in this work will come with practice.

Before starting to weld be sure that the welding electrode and the metal piece to be welded are properly and securely connected to the two terminals of the welding power supply, and the transformer or generator properly adjusted for correct voltage and current. Also be sure that the surface to be welded is clean and free from grease, oil, paint, rust or scale. A wire brush is generally used for removing rust and scale. Gasoline can be used to remove oil and grease but the gasoline should be wiped off or dried off before starting to weld because otherwise its fumes will interfere with the arc.

STRIKING THE ARC

When starting to weld, the electrode should be lightly tapped against the metal and quickly removed a short distance, about 1/16 of an inch. Then more slowly draw the arc out to its proper welding length. If the electrode is allowed to rest on the metal for even a second it is likely to stick or weld itself fast to the metal. If this happens, the electrode can usually be broken loose by bending rapidly back and forth and pulling. If this does not free it, the power should be switched off and the rod broken loose with a hammer.

After practicing striking the arc and holding it the right length, start running "beads" by slowly moving the electrode and arc along the metal in a straight line. Use a thin flat piece of steel plate, strap iron, angle iron, or a piece of cast iron, and

practice this until you can run a smooth bead. The important thing in running a bead is to keep the hand steady, hold the arc the right length to avoid excessive spatter and to secure good penetration or bonding of the weld metal with the metal on which it is being deposited. The electrode must of course be steadily moved downward toward the metal in order to keep the arc the same length as the electrode melts away.

If the electrode is moved along the metal too fast, the bead will be spotty or irregular and the penetration of the weld metal will be poor. The electrode must move slowly enough to permit the base metal to heat up and become molten, in order for the weld metal to fuse or alloy properly with it. A good test of penetration is to chisel off the bead, flush with the base metal, and see if it easily cracks loose, or if it is really welded into and joined thoroughly with the metal which was welded.

If the bead cracks off easily it shows poor bonding, due to dirty surface or insufficient heat and penetration.

If the electrode is moved too slowly the bead deposit will be too high and irregular.

When using welding generators or transformers which are adjustable, it is important to adjust them for the proper current and voltage, depending upon the size of the electrode used. Too much current will cause excessive sputtering and an unstable arc. Too little current makes the arc hard to hold and does not melt or penetrate the base metal properly unless the electrode is moved very slowly.

The electrode should be tilted slightly in the direction the bead is to be run, in order to cause the arc to blow back and deposit the weld metal in a bead or ridge to the rear of the electrode tip with respect to its direction of travel.

It requires considerable practice to develop instinctive knowledge and ability to control the arc length, electrode angle, rate of travel, and depth of penetration in arc welding. When you have acquired a knowledge of welding you will find this a very profitable spare time job field. We include additional INSTRUCTIONS ON WELDING IN OUR NEXT LESSON.

SPARE TIME JOB PLANS

AUTOMOTIVE GENERATORS

There are occasions when a small amount of alternating current power is desired for testing and experimental purposes, even though Direct Current may be available for power and lighting purposes. This is especially true in some rural districts where power is often obtained from individual D. C. power plants.

These ideas have been prepared to help men who desire to rebuild an old auto generator for use in supplying 110 volt A. C.

We have selected the generator used on the model T Ford inasmuch as this generator is available in practically all parts of the country.

There is only one major change necessary and that is to rewind the armature. The field coils do not require rewinding, however the field must be excited from a separate source of Direct current.

SELECTING THE GENERATOR

When selecting a generator for rebuilding, it is important to select one on which the bearings and commutator are in good condition, and if possible, the field coils should be O. K. However, if the field coils are not in good condition they may also be rewound.

PREPARING AN ARMATURE FOR WINDING

The old wire should be removed from the armature, and the slots should be carefully cleaned and prepared for the new winding.

In addition to the original slot installation it is advisable to add a layer of varnished cambric to increase the insulation sufficiently to protect against grounds in the higher voltage winding.

WINDING THE ARMATURE

The armature should be rewound for 4 poles as shown by Figure 1. About $\frac{3}{4}$ lb. of No. 25 S. C. E. wire will be required, but it is well to have on hand one full lb. of wire so that there is no danger of running short.

As shown by diagram in Fig. 1 the winding may be started at any point on the armature and that slot may be indicated by the figure "one."

Each pole consists of three coils. The first coil consisting of 115 turns is wound in slots "1" and

"2," the second coil, which is a continuation from the first, is wound in the same direction with 130 turns in slots "21" and "3," and the third coil continued from the second and also wound in the same direction consists of 65 turns in slots "20" and "4." The first pole winding is now in place and the next step is to tag or in some way mark the starting and finish ends of the coil so that they may be identified for connections when the other coils are in place.

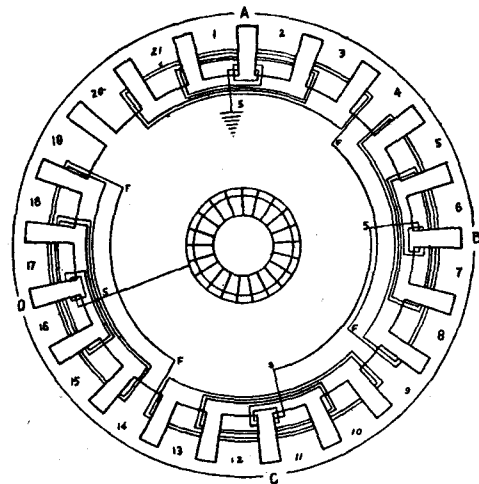

The second pole is wound in exactly the same way by placing the first coil of 115 turns in slots "6" and "7," the second coil of 130 turns in slots "5" and "8," and the third coil of 65 turns in slots "4" and "9." Note that one side of the last coil occupies the same slot as one side of the last coil on the preceding pole.

The first coil of the third pole is wound with 115 turns in slots "11" and "12," the second coil of 130 turns is placed in slots "12" and "13," and the third coil of 65 turns is placed in slots "9" and "14."

The fourth and last pole is wound with the first coil of 115 turns in slots "16" and "17," the second coil of 130 turns in slots "15" and "18," and the third coil of 65 turns is placed in slots "14" and "19."

Since there are an odd number of slots on the armature the coils in slots "19" and "20" do not overlap so these two slots are not as well filled with wire as the other slots. The remaining space in these two slots should be filled with wood wedges. The insulation in all slots should be carefully folded

down over the wire in the slot and wedges inserted to hold the wire and insulation in place.

CONNECTING THE COILS

The four sets of coils which make up the four poles should be connected together so that adjacent poles are of unlike polarity. As an example, if the pole center between slots "1" and "2" is a north pole then the pole center between "6" and "7" should be south, the pole between slots "11" and "12" should be north, and the pole center between slots "16" and "17" should be a south pole.

If all coils have been wound in the same direction the proper polarity may be obtained by connecting the finish of "A" pole to the finish of "B" pole, the start of "B" pole, to the start of "C" pole, and the finish of "C" pole to the finish of "D" pole. We now have remaining the start of the coil on pole "A" and the finish of the coil on pole "D." These two wires form the leads from which we obtain alternating current.

Before making permanent connections a test should be made to make sure proper connections have been made. Such a test may be made by connecting a battery between the two finish leads and testing with a compass. The compass should indicate opposite polarity on adjacent poles at four different points around the armature.

One of the leads is grounded by connecting it securely to the armature, and the other lead is connected to the commutator which is to be used as a slip ring or collector ring.

THE COMMUTATOR AS A SLIP RING

Slip rings used on regular A. C. machines consist of continuous brass rings and since the commutator is made up of segments which are insulated from one another, it is necessary to short them together by wrapping a piece of copper wire tightly around the commutator over the risers to which the old winding leads were connected. The wire should be carefully soldered to each riser and then the wire from the winding is securely soldered to this wire. The armature is now ready for use.

THE FIELD COILS

It will not be necessary to rewind the field poles providing they are in good condition. However, the coil ends must be disconnected from the brushes and provision made for connection to an external exciting source. The generator cannot be self-excited because we no longer have a commutator, and therefore no D. C.

The four field coils may be left connected in series with each other, and the exciting source may be any D. C. supply of proper voltage. A 6 volt storage battery will do very well and will build up sufficient field strength to develop a generator output of about 100 Watts. If it is desired to increase the Wattage output without increasing the exciting voltage it may be almost doubled by arranging the field coils in parallel series. This may be accomplished by splitting the connection between the coils so as to

leave two groups of two coils each connected in series. These two groups are then connected in parallel. It is important to maintain the proper relation between the coils so that adjacent poles are of unlike polarity.

The field may also be excited from any D. C. line or generator by using a rheostat or lamp bank to control the amount of current through the field. The field current may be as high as 3 amperes when not used for continuous duty. When on continuous duty the field current should be reduced somewhat.

The external A. C. line should be connected between the generator frame and one of the original brushes which rests on the commutator. Be sure that the brush selected for use is not grounded. The remaining brushes may be removed from the generator.

CONVERTING D. C. MOTOR INTO A WELDING GENERATOR

In the previous spare time job lesson we gave you some instructions on the construction of Arc Welding equipment. I also promised at that time to tell you how to convert a D. C. Motor into a Welding Generator. In the remainder of this lesson I want to explain how you can make this Welding Generator at very little cost.

Direct Current Motors of 10 to 20 h. p. may be converted into Welding Generators with little difficulty, providing they are compound wound machines. Some Motors may be adapted to this application by installing a series winding and providing separate excitation. The most desirable type of machine for Welding conversion, and the one that presents the least difficulty in making the change, is a 110-Volt 10 h. p. or 15 h. p. compound type motor. To adapt such a motor to welding work requires two necessary changes:

First, change the Armature winding from a simplex to a duplex connection; second, reconnect the shunt field coils, so that the normal voltage is imposed upon each coil when 55 volts is applied to the field. (See figure No. 1.) Changing the Armature winding from simplex to duplex will half the Armature voltage and double its current carrying capacity. Reconnecting the shunt field coils will insure normal field strength at the reduced voltage. After the above changes have been made, the 10 h. p. motor should deliver about 150 amps. at 55 volts, and the 15 h. p. unit will deliver approximately 240 amperes.

Before any changes on the Armature are attempted, the winding should be carefully examined to see whether it is lap or wave wound. If it is wave wound, the current carrying capacity of the Armature may be doubled by changing the winding to a lap connection; if it is lap wound, the connection must be changed from simplex to duplex. Either of these changes doubles the number of paths through the Armature, assuming the machine to have four poles, which is usually the case for motors of 10 h. p. to 15 h. p. rating. It is better, as a general rule, to change the winding from simplex to duplex,

regardless of whether it is lap or wave wound, since this change involves but little movement of the coil leads, and lessens the chance of breaking the wires; moreover, this method may be applied to either lap or wave windings.

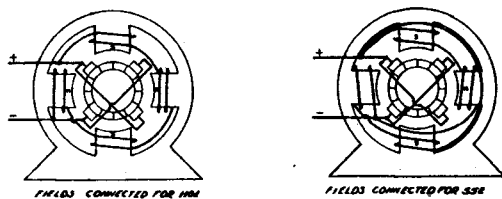

Figure 1. The above diagram shows how the field coils may be reconnected so as to maintain a normal field strength on half the original voltage. The left drawing shows all four coils connected in series and the drawing on the right shows the two series groups connected in parallel with each other.

The change is made by raising all of the top coil leads and moving them over a distance of one commutator bar. This is shown in the sketches "A" and "B" and figure No. 2. Note that in sketch "A," which shows the ordinary lap connection, the top lead "X" is connected to bar 2; "Y" is connected to bar 3; "Z" is connected to bar 4; and so on. After the change, the top lead "X" is connected to bar 3; "Y" is connected to bar 4; and "Z" to bar 5, as in figure 2B, and so on for all the other leads. This really amounts to merely moving all the top leads over a distance equal to one commutator bar. Note, too, that the bottom leads are undisturbed.

The same procedure is employed with a wave winding, except that with this type an odd number of commutator bars is sometimes employed. The odd bar may be eliminated by joining it to an adjacent bar and treating these two as one bar; the extra coil in this case must be left out of the circuit. In any case, before such a change is attempted, a complete

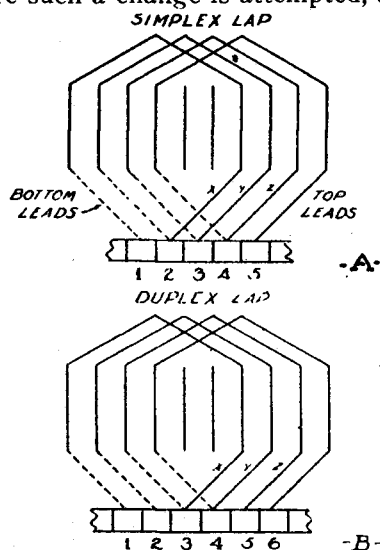

Figure 2. The above diagram shows how the current capacity of an armature may be doubled by changing the coil connections from simplex lap to duplex lap.

diagram of the Armature winding should be made, showing the connections both before and after the change, and the winding should be carefully traced.

Now, this procedure will eliminate the confusing mistakes that sometimes follow an attempted change of this sort, as it is much easier to check connections

on a diagram than on the actual machine.

An easier conversion than the above may be accomplished by separately exciting the field from a suitable D. C. source, such as a farm lighting plant, and reconnecting the fields if necessary. With such an arrangement at 15 h. p., 110-volt motor, will deliver over 200 amperes without any change in the armature winding. Such a welder could be driven by an engine of a Model "A" Ford, with some other suitable engine.

Should the machine be a compound type, the series field winding is usually connected differential, although both connections should be tried, as, due to the variations in design on different machines, it may be found that the cumulative connection gives better results.

Should the shunt field be separately excited, differential connection of the series field would generally produce the most satisfactory results. To give the welding circuit the falling voltage characteristic that is essential to such applications, it is necessary to place a resistor in series with the positive welding lead. This resistor should be capable of carrying—for reasonable intervals of time—the full load current of the machine, and should, if the welder is to be used on a variety of work, be adjustable. That is, arrangement may be made to short circuit sections of the resistors when heavy currents are carried. For the 10 h. p. machine a $\frac{1}{2}$ ohm resistor tapped as shown in figure 3, should be suitable, and for the 15 h. p. machine a $\frac{1}{3}$ ohm unit tapped in a similar manner may be employed. In case the arc is somewhat unsteady or unstable, increasing the series resistance will usually remedy the trouble.

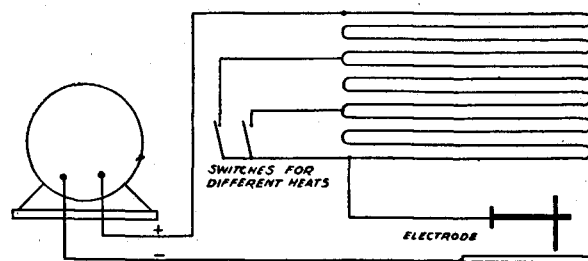

Figure 3. The above diagram shows how a resistance unit consisting of several lengths of iron pipe may be used with a welding generator. The diagram shows the positive lead connected to the electrode but as previously explained, this connection depends on the nature of the work.

The resistor may be composed of 8 or 10 lengths of $\frac{1}{4}$ -inch iron pipe, screwed together and bent into the form shown. This arrangement is compact and has current-carrying ability great enough for the purpose. Moreover, should prolonged operation cause undue heating, arrangements can be made for circulating water through the pipe.

With reasonable care in changing the connections as explained, and with a little experimental adjustment of the field strength and the load resistor, these converted D. C. motors can often be made to operate quite effectively as electric arc welding generators. Many profitable welding and repair jobs can usually be found for such a machine.

SPARE TIME JOB PLANS

ADAPTING INDUCTION MOTORS TO NEW OPERATING CONDITIONS

The rate at which many industrial plants are expanding their facilities for increased production is creating new responsibilities and opportunities for maintenance electricians.

Due to the difficulty involved in obtaining new equipment fast enough to meet expansion requirements, idle electrical machines of the older types are being rehabilitated and converted to use under changed conditions. Motors out of service for years are being adapted to new operating conditions by reconnecting or rewinding.

Every maintenance electrician should be alert to opportunities to convert such idle equipment to useful service.

The replacement of 25 cycle energy by a 60 cycle supply presents the problem of adapting the existing 25 cycle motors to 60 cycle operation. Three methods may be employed to accomplish the above: First, a change in applied voltage; second, a change in the winding connections; third, a complete rewinding job. The method ultimately employed in any given case will depend upon the conditions.

By the first method, a 110 volt 25 cycle motor may be operated from a 220 volt 60 cycle circuit, and a 220 volt 25 cycle motor can be connected to a 440 volt 60 cycle circuit. In both cases, the motor's speed and h. p. rating will be approximately doubled. The peripheral speed of the rotor must be given consideration in such a change, for, should the rim speed exceed 7,000 feet per minute, there is a possibility of the rotor being unable to withstand the increased centrifugal stresses. The speed of the machine driven by such a motor may be maintained at its normal value by reducing the size of the motor pulley to approximately one-half its original diameter, or by increasing the size of the driven pulley to twice its original diameter.

The second change—that of reconnection—is designed to enable the motor to operate at name-plate rated voltage on 60 cycles. This method can be employed on motors that are designated to operate on two voltages, such as 110-220 or 220-440. Thus a 110-220 volt 25 cycle motor may be changed to 60 cycle operation at 220 volts by connecting it the

same as for operation on 110 volts, 25 cycles. If the leads are not brought out, the internal sections of the windings may be paralleled. For example, a 4 pole, 220 volt, 25 cycle motor, having all poles connected in series, may be reconnected for a 220 volt 60 cycle circuit by having its poles connected two in series and the two groups in parallel; similarly, a 25 cycle single-circuit-star motor can be converted to 60 cycle operation on the same voltage by changing the connection to two-circuit-star. As in the previous examples, these changes will be accompanied by doubled speed and horsepower.

The last mentioned change—that concerned with rewinding—is generally necessary when 25 cycle motors have to be changed to 60 cycle operation without any considerable change in speed. This means that the motor must be wound for twice as many poles when operating on 60 cycles. The general rules for rewinding are:

Rewind the new coils for one-half the original coil span, using the next larger size of wire, and eighty-four per cent of the original turns. The winding connection will remain unchanged; that is, if the original winding was series-star, the new winding will be connected in a similar manner. With this arrangement, the horsepower and speed will increase about twenty per cent.

Sometimes a combination of speed and frequency change may be accomplished without rewinding, but such re-connections are rare. In general, the relationship to keep in mind is that the number of turns in series in any given phase or section of the winding must be made to vary in inverse proportion to the proposed change in frequency, and in direct proportion to the change in voltage.

With induction type motors, a change in speed invariably involves a change in the number of poles set up by the winding and, since this implies a variation in the coil span, rewinding is usually required. For example, to change the speed of a 1800 RPM motor to 900 RPM on the same voltage and frequency, rewind the stator employing one-half the original coil span and double the number of turns per coil. Wire size must be halved and original connections preserved. If the motor was originally

4 pole series star, the new winding will be 8 pole series star. Such a change will maintain the original torque but will decrease the horsepower in proportion to the speed. Changes from low to high speed demand consideration of the depth of iron behind the stator teeth, as a decrease in the number of poles increases the flux in this area.

When windings are changed for operation on a different voltage, frequency, or speed, it is important that the flux density in both the teeth and the back iron be unchanged. Low densities decrease the torque and power; higher densities result in overheating.

When such changes are made the following should be kept in mind:

1. Increase in the number of poles reduces the flux per pole in inverse proportion.
2. Increase in the number of poles reduces the speed of the rotating magnetic field in inverse proportion.

Thus when the number of poles in a winding is doubled, the flux per pole is halved; however, the total flux in the air gap is unchanged as there are twice as many poles with one-half flux per pole. Consequently, the torque developed is unchanged. But the speed of the rotating magnetic field is halved and the counter voltage is similarly reduced. The horsepower developed will reflect a proportionate decrease.

3. Increase in the frequency raises the speed of the rotating magnetic field and the counter-E.M.F. in proportion. If voltage applied to the winding is raised in proportion to the speed, the flux will remain constant, the torque will remain constant, but the horsepower will vary as the R.P.M.
4. When the coil span of a winding with a given number of poles is reduced, the C.E.M.F. generated by the winding is diminished in proportion.

Therefore the voltage applied to the winding must be decreased.

Taking all changes into consideration a 25 cycle, 2 pole motor will, when changed to 4 pole, 60 cycle with the same chord factor, have the same air gap flux, $\frac{1}{2}$ the back iron flux, 1800/1500 of the original speed and 1800/1500 of the original C.E.M.F. Since the C.E.M.F. should approximately equal the applied voltage the number of turns per phase will have to be reduced to 1500/1800 of the original value or 84%. Thus the machine should be rewound with 84% of original turns and one size larger wire.

In some cases the problem is one involving a change in the number of phases. As such changes may affect both speed and h.p. output, it is imperative that the ultimate results of the conversion be understood before reconnecting or rewinding is attempted. A modification not uncommon is the changing of a two-phase motor to three-phase operation. The possibilities associated with such a change will now be considered.

The simplest change with regard to phase variation is the reconnecting of a two-phase series-con-

nected motor to three-phase series-star. When so changed, however, the three-phase winding contains 25% more turns per phase than is required if the same value of line voltage is to be employed. In other words, a two-phase series-connected 220-volt motor will, when connected three-phase series-star, require a voltage of 275 volts between lines if the same voltage per coil is to be maintained. Since this is usually impracticable, normal voltage per coil may be obtained by cutting out one-fifth of the coils; these coils should be spaced around the stator as symmetrically as possible in order to avoid unbalanced phase voltages. Furthermore, since the normal full load current per line wire for a three-phase motor is 12.5% greater than that drawn by the two-phase motor for the same line voltage, it is evident that the three-phase h.p. will be less than rated two-phase h.p. by this amount. However, as the average motor will withstand a 15% overload without injury, equal h.p. on the three-phase connection may be obtained.

Due to the fact that the voltage impressed across the insulation between phases may equal the line voltage, motor manufacturers invariably place heavier insulation on the coils at the ends of the pole phase groups; therefore when a change from two-phase to three-phase is made, the insulation on the phase coils should be changed if the possibility of insulation breakdown is to be minimized. This change, which implies the insertion of extra insulation between the pole phase groups, should always be performed where conditions permit; however, where windings have been heavily doped, this may be impractical. On low voltage machines, it may be possible to effect a phase change that will perform satisfactorily without the extra insulation mentioned, although the strain on certain sections of the motor winding is increased, and the possibility of failure enhanced.

A combined voltage and phase conversion frequently made is the change from 440 volts two-phase to 550 volts three-phase. Under these circumstances, all stator coils are used effectively in both connections, the motor performing equally well under either condition. One precaution that must be strictly observed when making phase changes is the avoidance of parallel circuits, particularly where such circuits contain dead coils; for the prevention of circulating currents can be effected only if the voltages induced in the parallel sections are not only equal in value, but also in phase with each other. Thus it is possible to have two parallel circuits in a phase, each containing an equal number of coils, that will produce excessive heating due to the difference in phase of the induced voltages in the two apparently equivalent sections. It follows that a careful consideration of all of the factors affecting the ultimate distribution of current should be made before a change in the connection is attempted, as only by such a procedure can unsatisfactory performance be avoided.

When a change in the number of phases is contemplated, consideration of the relation between the number of slots per pole in the original and the proposed winding is essential, for a symmetrical winding is not possible unless the number of slots per pole is divisible by the number of phases. For example, if a 48 slot, 6 pole stator is to be converted from 2 phase to 3 phase operation, it will not be possible to get an equal number of coils per phase in each pole, as the number of slots per pole (8) is not divisible by the proposed number of phases (3). As there should be an equal number of coils in each phase, unequal coil grouping—an arrangement employed to insure the above requirement—must be used. The manner in which the coils may be arranged to achieve a balanced 3 phase winding in a 6 pole, 48 slot stator is indicated in the following chart.

	Phase A	Phase B	Phase C
1st pole	3	3	2
2nd pole	2	3	3
3rd pole	3	2	3
4th pole	3	3	2
5th pole	2	3	3
6th pole	3	2	3
	—	—	—
Total per phase	16	16	16

This method of obtaining a balanced winding is frequently used where a change in the number of phases is desired.

While this article does not cover all possible changes, it does show how a number of the frequently desirable conversions may be effected. By carefully following the instructions given, many of the owners of this set should be able to effect considerable savings and help to avoid production delays by converting idle motors to active use.

ONE of the leaders of the Electrical field once said "It's great to be in an industry that is such a vital part of everyone's life"—Yes, in the home, in industry, on the farm, in the air and on the sea, **in fact everywhere** we find **ELECTRICITY**, waiting to serve man. Those of us who are in this great industry should be grateful of the opportunity it offers to contribute to the progress of mankind.

Now, regardless of what purpose you had in mind in getting this **ELECTRICAL AND RADIO TROUBLE SHOOTING MANUAL**, my advice is to use it regularly. The more you learn about Electricity the more interesting it becomes. It provides a field for research and development the depth of which hasn't ever begun to be "sounded". I'd like to have you consider this book as one of your valuable possessions. I want you to prize it all your life for in it we have tried to give you the knowledge of an instructing staff on trouble shooting and shop print reading which they have **gained through years of experience**.

We want you to take advantage of our consultation service and **will welcome any opportunity to advise you on any subject in this book**.

With the hope that this manual will be a constant guide and help to you in your progress in the great field of Electricity and Radio and with best wishes for your success, I am

Sincerely,

HAROLD C. LEWIS, President
Coyne Electrical School
500 South Paulina St., Chicago, Ill.

FOREWORD TO DICTIONARY

The need of simple but accurate definitions of commonly used Radio and Electrical terms has existed as long as the Industries themselves. The Coyne Electrical School has made this Dictionary a part of the Coyne Electrical Trouble Shooting Manual for two very good reasons.

FIRST: A knowledge of the exact meaning of an expression or term will help a beginner, whether he be a student, an experimenter or any one else interested in the field to speed his progress and broaden his knowledge.

SECOND: The "old timer" also has need of an authoritative dictionary to serve as a reference guide on the precise meaning of many new Electrical and Radio terms. It enables him to be the authority in his plant.

This section contains over 1100 easy to understand definitions, abbreviations and terms most likely to be encountered in Radio or Electrical work. It also includes schematic symbols, tips on reading circuit diagrams and other useful information.

Whether you are a "beginner" or an "old timer" this Dictionary will be at your side whenever you need it. Get to learn the language of Electricity and Radio better by referring constantly to this section of your Trouble Shooting Manual.

We especially thank the Allied Radio Corporation, of Chicago, for their cooperation in helping us to prepare this valuable Electrical and Radio Dictionary.

A DICTIONARY OF ELECTRICAL, RADIO AND ELECTRONIC TERMS

A

A- (A negative or A minus.) Symbol used to designate the point in a circuit to which the negative terminal of the filament supply is to be connected.

A+ (A positive or A plus.) Symbol used to designate the point in a circuit to which the positive terminal of the filament supply is to be connected.

A BATTERY. The battery (often a single dry cell) used for supplying heating current to the filaments of radio tubes.

AB POWER PACK. A combination of batteries or devices in a single housing, used to supply potentials for receivers, especially portable sets.

A.C. Alternating current.

ACOUSTIC. Pertaining to sound.

ACOUSTIC FEEDBACK. Transfer of sound waves from a loudspeaker to any previous part, such as a microphone, in the same amplifying or broadcasting system. It can cause howling and overloading of tubes.

A.C.-D.C. RECEIVER. A receiver which will operate either from an a.c. or d.c. power source. It does not have a power transformer.

A.C. RECEIVER. A receiver designed to operate only from an a.c. power source. Power packs of these sets invariably employ a power transformer for stepping the a.c. line voltage up and down.

ACTIVE LINES. Periods during which the electron beam exists or is active in a television camera tube or picture tube, and is either scanning or else reproducing the lights and shades of the picture.

ADAPTER. Any device used for changing temporarily or permanently the terminal connections of a circuit or part.

ADJUSTABLE SPEED MOTOR. A motor whose speed may be varied gradually over a considerable range, and which then remains practically unaffected by changes in load.

ADMEDIUM LAMPHOLDER. A lampholder having a nominal screw diameter of 1 1/16 inch.

ADMITTANCE. The measure of ease with which an alternating current flows

in a circuit. The reciprocal of impedance. Measured in micromhos (mhos.).

AERIAL. An antenna.

A.F. Audio frequency.

AIR-CELL A BATTERY. A non-rechargeable wet-cell battery which usually is built to deliver 2 volts, for use chiefly in battery-operated home radio receivers. Its carbon electrodes are porous and absorb oxygen from the air during use. Rated life in normal radio use is 500 to 1500 hours, depending upon battery size and current drain.

AIR CORE. A term used to describe coils or transformers which have no iron in their magnetic circuits. Air-core construction is used chiefly in r.f. circuits.

AIR GAP. A path for electrical or magnetic energy through air between two objects, such as between the electrodes of a spark gap or between core sections of an iron-core transformer.

AIRPLANE DIAL. Popular name for a circular-shaped radio receiver dial with a rotating pointer, resembling the dials and pointers of airplane instruments.



Non-Metallic Screwdriver

TYPE OF ALIGNING TOOLS

ALIGNING TOOL. An essentially non-metallic screwdriver or socket wrench used for adjusting the trimmer condensers and adjustable coils which are provided in radio receivers for aligning purposes or for pre-setting push-button tuners.

ALKALI-TYPE BATTERY. A storage battery using an alkaline or non-acid liquid electrolyte; an Edison battery.

ALLIGATOR CLIP. A long-nose clip with spring-controlled meshing jaws used on test leads for making quick temporary connections.



ALL-METAL TYPE TUBE. A vacuum tube having a metal envelope instead of a glass envelope. Electrode connections are made through glass beads fused into the top and bottom of the metal envelope. The octal bakelite base is designed to take eight equally spaced

terminal prongs, but some of the prongs are omitted on tubes having less than eight terminals.

ALLOY. A mixture of two or more metals.

ALL-WAVE ANTENNA. A receiving antenna designed to pick up stations reasonably well over a wide range of carrier frequencies including short-wave bands as well as the broadcast band. It may be a single doublet antenna or a combination of two or more doublets.

ALL-WAVE RECEIVER. A receiver capable of receiving stations on all of the commonly used wavelengths in short-wave bands as well as the broadcast band.

ALTERNATING CURRENT. An electric current which reverses its direction of flow at regular intervals many times per second.

ALTERNATION. One-half of a cycle of alternating current, during which the current rises from zero to maximum value and returns to zero.

ALTERNATOR. A generator which produces alternating current.

A.M. Amplitude modulation. Also written as a-m or AM.

AMALGAMATE. To combine mercury with another metal, as on the surface of battery electrodes or plates.

AMATEUR. Any person who operates and experiments with short-wave transmitters as a hobby rather than for profit.

AMATEUR BANDS. Bands of frequencies assigned exclusively to radio amateurs by the Federal Communications Commission. Amateur band limits are:

1,715 to 2,000 kc.	28,000 to 30,000 kc.
3,500 to 4,000 kc.	56,000 to 30,000 kc.
7,000 to 7,300 kc.	112,000 to 116,000 kc.
14,000 to 14,000 kc.	224,000 to 230,000 kc.

Amateurs may also operate on any frequency above 300,000 kc.

AMATEUR OPERATOR. A person holding a valid license issued by the F.C.C. authorizing him to operate licensed amateur stations.

AMATEUR STATION. A radio station used by an amateur for personal communication with other amateurs.

AMATEUR STATION CALL LETTERS. Identifying call signal assigned to a licensed amateur operator to identify his station. Amateur calls in a given country begin with a one or two-letter prefix (W or N for U.S., and K for U.S. possessions), followed by a location-indicating numeral and two or more additional letters.

AMERICAN MORSE CODE. A dot-and-dash code which is commonly used for telegraphic communication over wires. It differs considerably from the International Morse Code which is used in radio.

AMMETER. An instrument used for measuring the current flow in amperes in a circuit.

AMP. Ampere.

AMPERE. The practical unit of electric current flow. The movement of 6,280,000,000,000,000 electrons past a given point in a circuit in one second con-

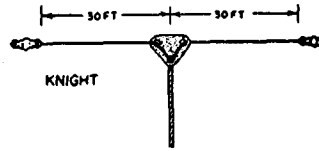
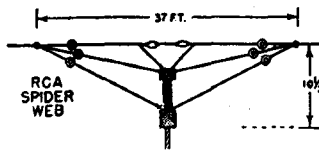
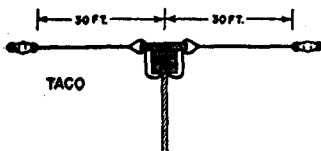
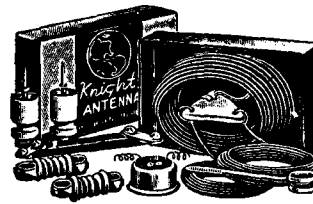
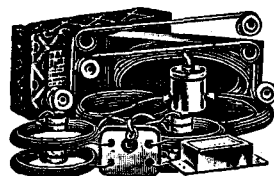
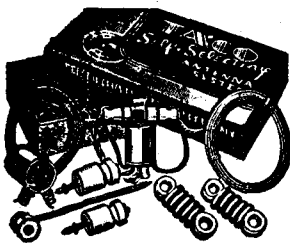

TYPES OF ALL-WAVE ANTENNAS

responds to a current of one ampere. When a one ohm resistance is connected to a one volt source, one ampere will flow.

AMPERE-HOUR. A current of one ampere flowing for one hour. This unit is used chiefly to indicate the amount of electrical energy a storage battery can deliver before it needs recharging.

AMPERE-TURN. A unit of magnetizing force, equal to the number of amperes of current multiplied by the number of turns of a winding in which it flows.

AMPLIFICATION. The process of increasing the strength (current, voltage or power) of a signal. Amplification can be provided by transformers and tuned circuits as well as vacuum tubes.

AMPLIFICATION FACTOR. A vacuum tube rating indicating the theoretical maximum increase in signal strength which can be provided by a given tube.

AMPLIFIER. A device consisting of one or more vacuum tubes and associated parts, used to increase the strength of a signal.

AMPLIFY. To increase in strength.

AMPLITUDE MODULATION. The common system of radio broadcasting, in which the deviation in frequency above and below the assigned carrier frequency value is equal to the frequency of the sound wave being transmitted, and the amplitude of the transmitted signal varies in accordance with the instantaneous amplitude of the sound wave being transmitted. Abbreviated as a.m., or a-m or AM.

ANALYZER. A test instrument used for checking radio parts and circuits. It sometimes includes a special plug-in system which can be inserted in a tube socket to extend the socket terminal to the instrument for convenience in making measurements.

ANODE. The radio tube electrode to which the main electron stream flows. The anode is also called the plate, and is usually placed at a high positive potential with respect to the cathode. It is usually identified on diagrams by the letter P.

ANT. Antenna.

ANTENNA. A metallic structure or an arrangement of conducting wires or rods used for picking up or radiating radio waves. Also known as an aerial.

ANTENNA COIL. That coil in a radio receiver through which the antenna current flows. This coil is usually directly connected to the antenna and ground terminals inside the set.

APPARENT POWER. The product of volts and amperes in an alternating-current circuit whose voltage and current are not in phase, in a circuit containing inductance, capacitance or both. Measured in volt-amperes.

APPLIANCE. Stationary or portable power-consuming equipment such as heating devices, cooking devices, and small motor-driven equipment.

ARMATURE. Usually the movable portion of a magnetic circuit, such as the

rotating section of a generator or motor, the pivoted iron portion of a magnetic loudspeaker, or the spring-mounted iron portion of a buzzer or relay.

ARTIFICIAL GROUND. A grounding electrode consisting of a metal plate, pipe or rod buried in the earth.

ARTIFICIAL MAGNET. A magnet made of iron or steel which has been magnetized, as distinct from a lodestone or natural magnet.

ASPECT RATIO. In television, a numerical ratio equal to picture width divided by picture height.

ATMOSPHERIC INTERFERENCE. Crackling and hissing noises reproduced in the radio loudspeaker due to electrical disturbances occurring in the atmosphere surrounding the earth; these disturbances radiate electro-magnetic waves which are picked up by antenna systems of receivers. Also called static interference, and particularly noticeable during thunderstorms.

ATOM. One of the elemental particles into which all matter is divided. An atom has a nucleus consisting of electrons and protons, with additional electrons revolving around the nucleus. Each of the 93 known elements has a different number and arrangement of electrons and protons in its atoms.

ATTENUATION. Reduction in the strength of an electrical impulse.

AUDIBLE. Capable of being heard by the human ear.

AUDIO AMPLIFIER. A vacuum tube device which increases the voltage and power of an audio frequency signal. It may be a separate piece of equipment or a section in a radio receiver.

AUDIO FREQUENCY. A frequency corresponding to an audible sound wave. The extreme limits of audio frequencies vary with the individual and are from about 20 cycles to about 20,000 cycles per second.

AUDIO TRANSFORMER. An iron-core transformer used for the dual purpose of coupling together two audio amplifier circuits and changing the value of an audio signal.

AUDIO OSCILLATOR. An oscillator which generates audio frequency voltages.

AUTOMATIC BASS COMPENSATION. A special resistor and condenser circuit used in some radio receivers to make low audio frequency notes sound more natural at low volume control settings. The circuit automatically compensates for the poor response of the human ear to weak low-frequency sounds.

AUTOMATIC BRIGHTNESS CONTROL. A circuit which automatically keeps the average brightness of the reproduced image constant in a television receiver.

AUTOMATIC FREQUENCY CONTROL. A special radio circuit which keeps a superheterodyne receiver tuned accurately to a given station. It is found chiefly on push-button tuned

receivers, where it corrects slight inaccuracies in the operation of the automatic tuning system.

AUTOMATIC RECORD CHANGER.

An electric phonograph which automatically plays a number of records one after another.



Some types play only one side of each record, while others are arranged to turn each record over and play both sides.

AUTOMATIC TUNING. An electrical, electro-mechanical or mechanical system which tunes a radio receiver automatically to a predetermined station when a button or lever is pushed.

AUTOMATIC VOLUME CONTROL. A radio circuit which automatically maintains the output value of a radio receiver constant within limits while the antenna is varying in amplitude over a wide range. It is used in practically all modern receivers, for it minimizes annoying fading of distant stations and prevents blasting when tuning suddenly from a weak station to a strong station.

AUTOMATIC VOLUME EXPANSION. A special audio circuit which increases the volume range of a radio program or phonograph record by making the weak passages weaker and making loud passages louder.

A.V.C. Automatic volume control.

AVERAGE VALUE. A voltage or current found by adding together a large number of instantaneous values and dividing by the number of values. In an alternation of sine wave form the average value is 0.636 times the maximum value.

AVIATION CHANNELS. Frequency bands assigned to aviation service for radio communication between aircraft and ground stations. These bands are both above and below broadcast band frequencies.

B

B—. (B negative or B minus.) Symbol used to designate the point in a circuit to which the negative terminal of the plate supply is to be connected.

B+. (B positive or B plus.) Symbol used to designate the point in a circuit to which the positive terminal of the plate supply is to be connected.

BACK EMF. Same as counter emf.

BACKGROUND NOISE. Noise heard along with a received radio program, due to atmospheric interference or to circuit conditions.

BAFFLE. A wood, metal or composition horn or flat surface used with a loudspeaker to increase the length of the air path from the front to the back of the loudspeaker diaphragm, thereby reducing interaction between sound waves produced simultaneously by front and back surfaces of the diaphragm. A baffle thus serves to direct the sound produced by a loudspeaker

and improve the fidelity of reproduction.

BAKELITE. A phenolic compound having high electrical resistance, used as an insulating material in the construction of radio parts such as panels, coil forms, tube sockets, etc.

BALANCED ARMATURE UNIT. An electro-magnetic sound-producing device used chiefly in magnetic loudspeakers. It has a small moving iron armature which is surrounded by windings carrying audio currents. The armature is pivoted between the poles of a permanent magnet. Variation in the audio current cause corresponding changes in magnetism, making the armature rock back and forth. A diaphragm coupled to the armature produces sound waves.

BALLAST RESISTOR. A special type of resistor used in radio apparatus to compensate for fluctuations in a.c. power line voltage. It is usually connected in series with the power supply to the receiver or amplifier. The ohmic value of a ballast resistor increases automatically with increases in current through it, thereby tending to maintain essentially constant current despite variations in line voltage.

BALLAST TUBE. A ballast resistor mounted in an evacuated glass or metal envelope. This construction improves the automatic voltage regulating action by reducing radiation of heat from the resistor element.

BAND. In radio, frequencies which are within two definite limits and are used for a definite purpose. Thus, the standard broadcast band extends from 550 kc. to 1600 kc.

B. & S. GAUGE. Brown and Sharpe wire gauge, the standard gauge used in the United States to specify wire sizes.

BAND SWITCH. A switch which simultaneously changes all tuning circuits of a radio receiver or transmitter to a desired band of frequencies.

BANDSPREAD TUNING CONTROL. A small variable condenser connected in parallel with the main tuning condenser of a short-wave receiver to provide more accurate tuning.

BANTAM TUBE. A compactly designed tube having a standard octal base but a considerably smaller glass envelope than does a standard glass tube. Bantam tubes are used chiefly in compact table model receivers and in battery-operated portable sets.

BANTAM JR. TUBE. An extremely small glass vacuum tube with a special bantam jr. base, used chiefly in hearing aid units.

BASS. Low audio frequencies.

BASS CONTROL. A manually-adjusted control provided on a radio receiver for the purpose of emphasizing the loudness of the bass notes in a radio program.

BASS COMPENSATION. Any means of offsetting the natural drop in the response of the human ear to low audio frequencies at low volume levels.

BASS RESPONSE. The ability of a loudspeaker to handle low audio notes,

or the sensitivity of the human ear to low audio notes.

BATTERY. One or more dry cells or storage cells connected together to serve as a d.c. voltage source.

BATTERY RECEIVER. A receiver which uses batteries as a power source.

BAYONET BASE. A type of tube and lamp base having two projecting pins on opposite sides of the smooth cylindrical base; these engage in corresponding slots in the bayonet shell socket.



B BATTERY. A battery having many small cells connected in series, used for supplying d.c. voltages to the plate and screen grid electrodes of radio tubes used in battery-operated equipment.

BEAM POWER AMPLIFIER TUBE. A special type of vacuum tube designed for use in the output stage of a radio receiver. Deflecting electrodes concentrate the electrons into beams to give high power output along with desirable operating characteristics.

BEAT FREQUENCY. The frequency obtained when signals of two different frequencies are combined and rectified. The beat frequency is equal in numerical value to the difference between the original frequencies.

BEAT FREQUENCY OSCILLATOR. An audio frequency oscillator whose output is obtained by combining and rectifying two known higher-frequency signals which are generated by or obtained from separate circuits.

B ELIMINATOR. An a.c. power pack which converts a.c. power line voltage to the pure d.c. circuits of radio tubes, thereby eliminating the need for B batteries.

BELL WIRE. A common term for the cotton-covered B. & S. No. 18 copper wire used for making doorbell and thermostat connections in homes.

BIAS. The fixed voltage applied between the control grid and cathode electrodes of a radio tube. Also called C bias.

BIAS CELL. A tiny 1-volt or 1½-volt cell used singly or in series to provide a negative C bias voltage for a vacuum tube amplifier circuit. It will last indefinitely if not overloaded.



BIPOLAR. Having two magnetic poles, one north and the other south. Two-pole.

BLACK LEVEL. The steady level of television carrier current or voltage while not modulated by any of the signals. The base or starting value above which rise the synchronizing and equalizing voltages of the television signal.

BLANKING SIGNAL. The portion of a television signal that blanks or extinguishes the electron beam in the picture tube of the receiver while the beam is being blanked in the camera tube at the transmitter.

BLASTING. Overloading of an amplifier or loudspeaker, resulting in severe distortion of loud sounds.

BLEEDER CURRENT. A current drawn continuously from a power pack to improve its voltage regulation or to increase the voltage drop value across a particular resistor.

BLEEDER RESISTOR. A resistor which is used to draw a fixed bleeder current value from a power pack.

BLOCKING CONDENSER. Any condenser used in a radio circuit to block the flow of direct current while allowing a.c. signal currents to pass.

BLOOPER. Slang term applied to a regenerative receiver which radiates a signal when improperly tuned.

BODY CAPACITY. The capacity existing between the human body and a piece of radio apparatus.

BOND. A connection between metallic parts which makes them a continuous electrical conductor.

BONDING. Connecting the metal housings and shields of radio parts together or to the chassis with heavy wire so they will be at the same potential (usually ground potential.)

BRANCH CIRCUIT. The portion of a wiring system that extends beyond the final overcurrent device (fuse, cutout or circuit breaker) that protects the circuit. The portion of the circuit leading to lamps, appliances and other power-consuming equipment.

BREAKDOWN VOLTAGE. The voltage at which the insulation between two conductors will break down and become conductive.

BRIGHTNESS CONTROL. In a television receiver, the control which varies the average illumination of the reproduced image.

BROADCAST. A radio transmission intended for reception by the general public.

BROADCASTING. A general term applying to the radiation of radio waves carrying programs intended for public interest, education, or entertainment.

BROADCAST BAND. The band of frequencies between 550 kc. and 1600 kc., to which are assigned all standard broadcast stations operating in the United States.

BROADCAST STATION. A radio station used for transmitting programs to the general public.

BROAD TUNING. A condition wherein two or more stations are picked up at one setting of a receiver tuning dial, due to lack of selectivity in the tuning circuits.

BRUSH. A stationary conductor held in contact with a moving conductor or conductors to allow flow of current between stationary and moving parts of electrical equipment.

BUCK. To oppose.

BUFFER. Any part or circuit used to reduce undesirable interaction between radio circuits.

BUFFER CONDENSER. A condenser connected between the anode and cathode of a cold-cathode rectifier tube to reduce voltage surges which might affect following parts in the apparatus.

BUFFER STAGE. An amplifier stage used to prevent feed-back of energy from a power stage to a preceding stage.

BUG. A semi-automatic code transmitting key in which movement of a lever to one side produces a series of dots, and

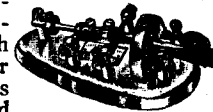

movement to the other side produces a single dash.

BUILT-IN AERIAL. An aerial which is an integral part of a radio receiver. It may be a loop aerial, a power line connection or a sheet of metal mounted in the receiver cabinet.

BUSWAY. A protective enclosure for buses, which are conductors formed by bars or rods of large cross section.

BUZZER. An electromagnetic device in which attraction of an armature by an electro-magnet interrupts the current flow; a spring then pulls the armature back, closing the circuit again so that the process repeats itself and creates a buzzing sound.

BX. Flexible metal conduit used to protect power line wiring in buildings and in high-power radio apparatus.

BY-PASS CONDENSER. A condenser used to provide a low-impedance path for radio or audio signals around a resistor or between a circuit terminal and ground.

C

C. Letter used to designate a condenser, a grid bias voltage, or the centigrade temperature scale.

C- (C negative or C minus.) Symbol used to designate the point in a vacuum tube circuit to which the negative terminal of the grid bias source is to be connected.

C+ (C positive or C plus.) Symbol used to designate the point in a vacuum tube circuit to which the positive terminal of the grid bias source is to be connected.

CABINET. An enclosure for switches fuses and wire connections, designed for either surface or flush mounting and having a frame or trim on which are hung swinging doors.

CABLE. A stranded conductor (called a single-conductor cable) or a combination of conductors insulated from one another (called a multiple-conductor cable).

CADMIUM. A metal sometimes plated on a steel chassis to improve its appearance and prevent rusting.

CALL LETTERS. Government-assigned identifying letters for a radio station.

CAM. An irregular-shaped rotating or sliding part used to convert rotary motion to linear motion, or vice versa. Used extensively in mechanical push-button tuning systems.

CANDELABRA LAMPHOLDER. A lampholder having a nominal screw diameter of $\frac{1}{2}$ inch.

CAPACITANCE. Electrostatic capacity.

CAPACITIVE REACTANCE. The effect of capacitance in opposing the flow of alternating or pulsating current.

CAPACITOR. Condenser.

CAPACITOR. A condenser or an electrostatic condenser.

CAPACITOR MOTOR. A split-phase motor in which a capacitor or capacitors displace part of the current in phase from the remainder in order that the motor may be self-starting on single-phase supply current.

CAPACITY. The electrical size of a condenser, determining the amount of electrical energy which can be stored in a condenser by a given voltage. In radio work, capacity is measured in microfarads (mfd.) and micro-microfarads (mmfd.); 1 mfd. is equal to 1,000,000 mmfd.

CAPACITIVE COUPLING. A type of coupling in which a condenser provides a direct path for signal energy between two circuits.

CAPACITIVE REACTANCE. The reactance which a condenser offers to a.c. or pulsating d.c. It is measured in ohms, and decreases as frequency and capacity are increased.

CARBON. An element used in the construction of radio parts such as resistors, dry cells, and microphones.

CARBON RESISTOR. A resistor made of carbon particles and a ceramic binder molded into a cylindrical shape, with leads attached to opposite ends.

CARBORUNDUM. A compound of carbon and silicon used in crystal form to rectify or detect radio waves, as in a crystal detector.

CARRIER. A current, voltage or radio wave having the assigned frequency of a radio station. When no sounds are being transmitted, such as during a pause between portions of a program, only the unmodulated carrier signal is present in the transmitting and receiving system.

CARRIER FREQUENCY. The frequency of the original unmodulated radio wave produced by a transmitter. In the case of a broadcast station, the carrier frequency must be maintained within a few cycles of the frequency value assigned to that station by the Federal Communications Commission.

CARTRIDGE FUSE. A fuse enclosed with an insulating and protective covering and provided with connections at its ends.

CATHODE. The electron-emitting electrode of a radio tube. Thermionic vacuum tubes employ heated cathodes; the heat is either supplied indirectly by a filament located inside the cathode or is supplied by current flowing through the cathode itself. In this latter case, the cathode is also the filament.

CATHODE RAY. A ray or beam of electrons emitted from a cathode.

CATHODE RAY TUBE. A special type of vacuum tube in which a beam of electrons is directed at a fluorescent screen by an electron gun, producing a green or white glow on the screen at the point of impact. The beam passes between electrostatic deflecting plates or electromagnetic deflecting coils which can make it bend enough to produce any desired pattern or pic-

ture on the screen when the proper varying voltages are applied to the deflecting system.

CATHODE RAY TELEVISION TUBE. The cathode ray tube used in modern television receivers to reproduce the scenes being transmitted.

CATHODE RAY TUNING INDICATOR. A small cathode ray tube used in radio receivers to indicate when a station is tuned in accurately.

CATHODE RAY OSCILLOSCOPE. A test instrument using a cathode ray tube to make visible the wave form of a varying current or voltage.

CATWHISKER. A small, sharply pointed wire used in crystal detector to make contact with a sensitive point on the surface of the crystal.

C BATTERY. The battery used for supplying a negative C bias to the control grid of a vacuum tube.

C BIAS. An applied voltage used to bake the control grid of a vacuum tube negative with respect to the cathode.

CELL. A single unit capable of serving as a d.c. voltage source. A primary cell, such as a dry cell, cannot be recharged when exhausted. A secondary cell, such as the cell of a storage battery, can be recharged when exhausted by passing a current through it in the reverse direction.

CENTERING CONTROL. In a television receiver, a control used to shift the entire reproduced image on the screen. The horizontal centering control moves the image horizontally in either direction, while the vertical centering control shifts the image up or down.

CENTIGRADE. The European scale of temperature in which 0 is the temperature of melting ice and 100 is the temperature of boiling water at sea level.

CENTIMETER. In the metric system of measurements, a unit equal to one-hundredth of a meter, or approximately .39 inch. There are 2.54 centimeters in one inch.

CHAIN. In radio, a network of radio stations connected together by special telephone lines so that all can broadcast simultaneously a program originating at a key station.

CHANNEL. A narrow band of frequencies including the assigned carrier frequency, within which a radio station is required to keep its modulated carrier signal in order to prevent interference with stations on adjacent channels. Also, one branch or path over which radio signals may travel; thus, a p.a. system may have several input channels, each with its own sound pick-up device, transmission line and volume control.

CHARGE. A quantity of electrical energy held on an insulated object. The electrical energy stored in a condenser. The act of supplying electrical energy to a metal object, to a condenser, or to a storage battery. When an object has more electrons than normal, it has a negative charge. When an object has less electrons than normal, it has a positive charge.

CHARGER. A device used to convert alternating current into a pulsating direct current which can be used for charging an exhausted storage battery.

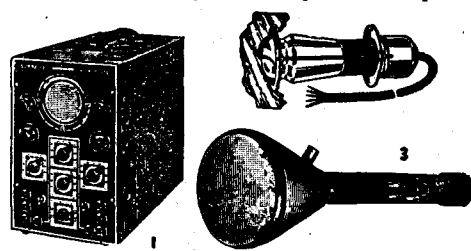

(1) Cathode Ray Oscilloscope.
(2) Cathode Ray Tuning Indicator.
(3) Cathode Ray Television Tube.

CHASSIS. The metal framework on which the parts of a radio receiver or transmitter are mounted. Also used to designate the completed piece of radio equipment before it is mounted in a cabinet.

CHOKE COIL. A coil used to limit the flow of alternating current while allowing direct current to pass. R.F. choke coils have air or pulverized iron cores, while a.f. choke coils and filter chokes have iron cores.

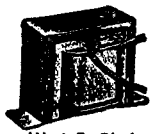

(1) A.F. Choke.

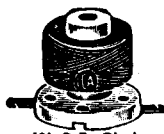

(2) R.F. Choke.

CIRCUIT. A complete path over which an electric current can flow.

CIRCUIT BREAKER. A device for automatically opening a circuit in case of over-current in this or another circuit, and sometimes for opening the circuit in case of under-voltage.

CIRCUIT VOLTAGE. The greatest effective difference of potential between any two conductors in the circuit considered.

CLIP. A small spring-type clamp having any of several different designs, used for making a readily removable connection to a terminal.

CLOCKWISE. The direction in which the hands of a clock move.

COAXIAL CABLE. A two-conductor cable in which one conductor is a flexible or non-flexible metal tube and the other is a wire centrally supported inside the tube by insulators.

CM. Centimeter.

CODE. A system of dot and dash signals used in the transmission of messages by radio or wire telegraphy. The International Morse Code (also called the Continental Code) is used everywhere for radio telegraphy. The American Morse Code is used commonly for wire telegraphy.

CODE RECORDER. An instrument which makes a permanent record of code messages received by radio or otherwise.

COIL. A number of turns of wire wound on an iron core or on a coil form made of insulating material. A coil offers considerable opposition to the passage of alternating current but very little opposition to direct current.

COIL FORM. The tubing or solid object on which a coil is wound. It can have any shape and can be made from any insulating material, such as paper, cardboard, fiber, bakelite, a plastic or ceramic materials, or wood.

COLD CATHODE. A cathode which does not depend upon heat for electron emission. The cold cathode of a photoelectric tube emits electrons when exposed to light, while in a type BH rectifier tube the electrons are pulled out of the cold cathode by a sufficiently high voltage applied to the pointed anode.

COLLECTOR RINGS. Continuous metallic rings on a rotating member, against which bear stationary brushes to allow current flow between the rotating and stationary parts of the equipment.

COLOR CODE. Any system of colors used to specify the electrical value of a radio part or identify terminals and leads.

COMMUNICATION RECEIVER. A receiver designed especially for reception of code or voice messages transmitted by short-wave radio communication services.

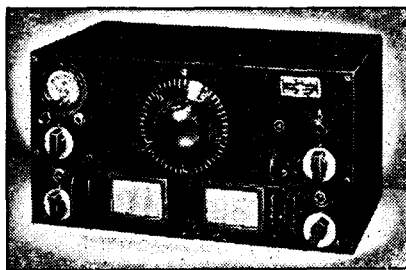

COMMUTATION. Conversion of alternating current generated in the armature of a direct-current machine to direct current for the external circuit.

COMMUTATOR RIPPLE. Small pulsations in the voltage and current taken from a direct-current generator.

COMPOUND MAGNET. A permanent magnet consisting of several similarly shaped single magnets in close contact and with like poles together.

CONCENTRIC CABLE. Coaxial cable.

CONDENSER. A radio part consisting of two conducting surfaces separated from each other by an insulating material such as air, oil, paper, glass or mica. A condenser is capable of storing electrical energy. In radio circuits, condensers are used to block the flow of direct current while allowing alternating and pulsating currents to pass. The electrical size or capacity of a condenser is specified in microfarads and micro-microfarads.

CONDUCTIVITY. The ability of a material to carry electric current.

CONDUCTOR. Any substance in which a difference of voltage between two points causes current to flow between these points. One or more wires carrying a single current.

CONDUCTOR. A wire or other metal structure which provides a path for electric current between two points. A conductor is thus a material which offers little opposition to the continuous flow of electric current.

CONE. The conical-shaped paper or fiber diaphragm of a magnetic or dynamic loud-speaker.

CONNECTOR. A device for joining electrical conductors either by soldering or by mechanical pressure applied with screws.

CONSOLE. A large radio receiver cabinet, designed to rest on the floor rather than on a table.

CONTACT. A terminal to which a connection can be made. A joining of bodies to permit the flow of electrical current.

CONTACTOR. A magnetically operated switch for opening and closing circuits carrying large currents.

CONTINENTAL CODE. Same as the International Morse Code. Used universally for radio telegraphy.

CONTRAST CONTROL. In a television receiver, a manual control which adjusts the range of brightness between highlights and shadows of the reproduced image.

CONTROL GRID. That electrode in a vacuum tube which has the most effective control over the plate current passed by the tube. The control grid is usually the electrode nearest to the cathode.

CONTROL PANEL. An exposed or enclosed upright panel carrying switches and other controlling, measuring and protective devices for electrical machinery or equipment.

CONVERTER. That section of a superheterodyne radio receiver which changes incoming modulated r.f. signals to a lower frequency known as the i.f. value; the converter section includes the oscillator and the first detector. Also, a device, usually rotary, changing electrical energy from one form to another, as AC to DC.

COPPER-OXIDE RECTIFIER. A rectifier made up of discs of copper coated on one side with cuprous oxide. The discs allow direct current to flow in one direction but allow very little current flow in the reverse direction.

CORE. The center of a coil.

COUNTER-CLOCKWISE. In a direction opposite that in which the hands of a clock rotate.

COUNTER EMF. In a circuit containing self-inductance, a voltage produced by changes of current and which at every instant opposes the change of current that produces the voltage.

COUNTERSINK. To ream, drill or cut a conical depression around a hole for a flat-head screw, so that the screw head will be flush with the surface of the work.

COUPLING. The means by which signals are transferred from one radio circuit to another. Coupling can be direct through a conductor, electro-static through a condenser, or inductive through a transformer. Also, a connecting device.

COUPLING. Any means by which electrical energy is transferred from one circuit to another, with changes of voltage or current in one circuit producing corresponding changes in the other.

C.R.O. Cathode ray oscilloscope.

CRYSTAL. A piece of natural quartz or similar piezo-electric material which has been ground to a size which will vibrate naturally at a desired radio frequency and generate that frequency when set into vibration. A quartz crystal is used in radio transmitters to generate with a high degree of accuracy the assigned carrier frequency of a station, and is used in crystal filters of radio receivers to improve the selectivity of the i.f. amplifier. The mineral used in a crystal detector is known as a crystal.

CRYSTAL CONTROL. Use of a quartz crystal to maintain operation of a radio station at its assigned frequency within the limits prescribed by law.

CRYSTAL DETECTOR. A detector utilizing a crystal such as silicon or galena in contact with a pointed wire

to rectify an incoming radio signal. Used in crystal receivers.

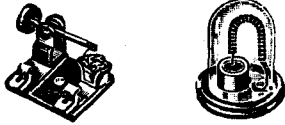

TYPES OF CRYSTAL DETECTORS

CRYSTAL FILTER. A highly selective tuning circuits employing a quartz crystal, sometimes used in the i.f. amplifier of a communications receiver to improve selectivity so as to permit reception of a desired station even when there is strong interference from other stations on nearby channels.

CRYSTAL PICK-UP. A type of phonograph pick-up in which the needle movements bend or twist a Rochelle salt crystal element and cause the crystal element to generate an audio frequency voltage corresponding to the recorded sound waves.

CRYSTAL SET.

A radio receiver which uses a crystal detector for signal rectification, and has no vacuum tubes.

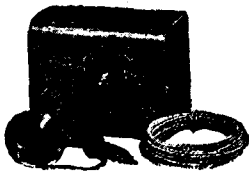

CURRENT. The movement of electrons through a conductor. Current is measured in amperes, in milliamperes and in micro-amperes.

CURRENT. Flow of electricity in conductors. The unit of current measurement is the ampere. Current is movement of free electrons along a conductor.

CUTOUT BOX. A surface-mounted covered enclosure for cutouts.

CUTTING HEAD. That part of a sound recorder which cuts or embosses on a disc, the irregular grooves corresponding to the wave form of the sounds being recorded.

C.W. Continuous wave.

CYCLE. One complete reversal of an alternating current, including a rise to a maximum in one direction, a return to zero, a rise to a maximum in the other direction, and another return to zero. The number of cycles occurring in one second is the frequency of an alternating current. The word cycle is commonly interpreted to mean cycles per second, in which case it is a measure of frequency.

CYCLE. In an alternating current, the increases, decreases and reversals of direction which carry the current through one complete set of changes or one complete set of motions in opposite directions. A cycle consists of two alternations.

D

DB. Decibel.

D.C. Direct current.

D.C.C. Double cotton covered insulation on wires.

D.C. RECEIVER. A receiver designed to operate from a d.c. power line, such as from the 110-volt d.c. lines still being used in older sections of some cities.

D'ARSONVAL METER MOVEMENT.

The commonest movement employed in precision direct current measuring instruments. It consists essentially of a small coil of wire supported on jeweled bearings between the poles of a permanent magnet, with a spiral spring holding the coil and the attached indicating pointer at the zero position on the meter scale. When the current to be measured is sent through this coil, the magnetic fields of the coil and magnet interact to cause rotation of the coil and pointer.

DEAD END. The ends of circuit wires which are attached to supports but which are not connected to any load.

DEAD SPOT. A region in which signals from certain radio stations are poorly received.

DECIBEL. A unit used for comparing the power level of a signal to a fixed reference level of power. Also a measure of power, current or voltage gain.

DELAYED A.V.C. An automatic volume control circuit which does not begin to act until signals reach a certain strength. It permits reception of weak signals even though they are fading at times, whereas normal a.v.c. tends to make weak signals weaker.

DEFINITION. In television, the clearness with which all detail in the scene are being reproduced.

DEGENERATION. A type of feedback which reduces signal strength. Degeneration is the opposite of regeneration.

DEMAND FACTOR. The ratio of the maximum demand of a system, or part of a system, to the total connected load of the system or the part of the system considered. The maximum watts actually used at any time, divided by the total wattage of all equipment connected to the system.

DEMODULATION. The process of rectifying or detecting a modulated radio signal in order to remove the carrier and obtain the desired audio or picture signal.

DETECTOR. That stage in a receiver at which demodulation takes place. In the detector stage of a r.f. receiver, the r.f. signals are separated from the desired audio signal. In the second detector of a superheterodyne receiver, the i.f. signals are separated from the desired audio signal.

DIAL. Any means for indicating the value to which a control knob has been adjusted. Tuning dials of broadcast band receivers indicate the frequency to which the receiver is tuned, either in kilocycles directly or in kilocycle values having one zero removed; sometimes the wavelength in meters will also be indicated.

DIAL CABLE. The braided cord or flexible wire cable used to make a tuning knob control the position of the pointer or dial which indicates the frequency to which a radio receiver is tuned.

DIAL LIGHT. The pilot lamp which illuminates the tuning dial of a radio receiver.

DIAPHRAGM. A thin, flexible metallic or non-metallic sheet which vibrates when struck by sound waves, as in a microphone, or which produces sound

waves when moved back and forth at an audio rate, as in a headphone or loudspeaker.

DIELECTRIC. Any insulating material, but usually one having such exceedingly high electrical resistance as to effectively prevent flow of any current through it. A dielectric used between conductive plates in a condenser receives and retains the electric charge of the condenser. Air, mica, glass and paper are common dielectrics.

DIELECTRIC CONSTANT. The dielectric constant of a material is the ratio of the capacitance of a condenser using that material as its dielectric to the capacitance of a condenser otherwise similar but having air or a vacuum for the dielectric. The increase of capacitance caused by using the material instead of air for the dielectric.

DIELECTRIC STRENGTH. The number of volts required to break down or puncture an insulating material, and thus to permit flow of current through the material.

DIODE. A vacuum tube having two electrodes, one being the cathode and the other the plate or anode. A diode allows electrons to pass in only one direction, from the cathode to the anode.

DIRECT COUPLING. The use of a conductor to connect two circuits together and provide a direct path for signal currents.

DIRECT CURRENT. An electric current that flows always in the same direction in its circuit. The current may be steady or of constant value, or it may vary in strength, or there may be intervals of no current, but so long as current that does flow always moves in the one direction it is a direct current.

DIRECTIONAL ANTENNA. Any antenna which picks up or radiates signals better in one direction.

DIRECTION FINDER. A special type of radio receiver employing a highly directional loop antenna so as to permit determining the direction from which radio waves are arriving.

DISCRIMINATOR. In an F.M. receiver, the section which converts frequency modulated signals into audio signals.

DISCRIMINATOR. In a frequency modulated radio receiver, the tube and circuit which change the frequency modulation into variations of voltage at audio frequency, serving the same purpose as the second detector in an amplitude modulated superheterodyne receiver.

DISTORTION. Improper reproduction of a sound or television radio program due to changes occurring in the wave form of the intelligence signal somewhere in the path it takes through the transmitting and receiving system or through an amplifier system.

DISTRIBUTED CAPACITY. Capacity distributed between conducting elements such as wires, as distinguished from capacity concentrated in a condenser. Usually used to specify the small capacity existing between the turns of wire in a coil.

DOUBLE-BUTTON CARBON MICROPHONE. A carbon microphone employing two buttons or containers

for carbon granules, one on each side of the diaphragm, so as to secure a push-pull action which gives increased signal output.

DOUBLE-POLE. Descriptive of a switch or other device connected in both sides of a circuit, or controlling both sides of the circuit at one time.

DOUBLE POLE SWITCH. A switch which simultaneously opens or closes two separate circuits or both sides of the same circuit.

DOUBLE THROW SWITCH. A switch which connects one circuit terminal to either of two other circuit terminals.

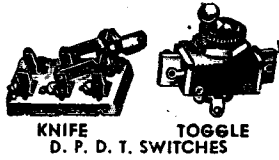

KNIFE
D. P. D. T. SWITCHES
TOGGLE

DOUBLE ANTENNA. An antenna system with an insulator inserted at its exact center, with one lead of a two-wire transmission line connected to each half of the antenna at this insulator.

D.P.D.T. Double pole, double throw.

D.P.S.T. Double pole, single throw.

DRAIN. A term used to indicate that current is being taken from a voltage source.

DRIVER. A stage of amplification used to feed or drive a final stage of amplification for the purpose of making the final stage operate at maximum efficiency.

DROP. The voltage drop developed across a resistor due to current flow through the resistor.

DRY CELL. A type of primary cell in which the electrolyte is in the form of a paste rather than a liquid. Dry cells are used extensively in radio batteries.

DRY CELL. A primary cell having a zinc outer can as its negative electrode, a central carbon rod as its positive electrode, and a liquid electrolyte of a small quantity of sal ammoniac and zinc chloride held in an absorbent lining and in a mass of powdered graphite and manganese dioxide, these latter two materials being the depolarizer. The cell is sealed. Its voltage is approximately 1.5.

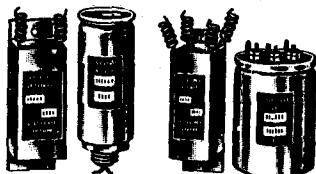

Dry Electrolytic Condensers

DRY ELECTROLYTIC CONDENSER. An electrolytic condenser in which the electrolyte is a paste rather than a liquid, to permit using the condenser in any position without danger of the electrolyte leaking out.

D.S.C. Double silk covered insulation on a wire.

DUMMY ANTENNA. A resistor or other device which duplicate the electrical characteristics of a transmitting antenna without radiating radio waves. Used for testing and adjusting transmitters.

DURALUMIN. An alloy of aluminum which is comparable in strength and hardness to soft steel. It contains 95.5 parts aluminum, 3 parts copper, 1 part manganese and .5 part magnesium.

DUSTPROOF. So constructed or protected that an accumulation of dust will not interfere with satisfactory operation.

DUST-TIGHT. So constructed that dust will not enter the enclosing case.

DX. A slang expression for distance, used chiefly in connection with reception of distant radio stations.

DYNAMIC LOUDSPEAKER. A loudspeaker in which the diaphragm or cone is attached to a small coil mounted so it can move within a constant magnetic field. Audio frequency currents flowing through this coil (called the voice coil) make it move in and out, thereby causing the diaphragm to reproduce sound waves. The magnetic field is produced by a permanent magnet in p.m. dynamic loudspeakers, and by an electromagnet in electrodynamic loudspeakers, and by an electromagnet in electrodynamic loudspeakers.

DYNAMOTOR. A rotating device acting both as motor and generator, used to change a d.c. voltage to an a.c. voltage or to a higher d.c. voltage. It is used chiefly for portable and mobile operation of radio transmitters and P.A. amplifiers from storage batteries.

E

E. Commonly used symbol for voltage.

EDDY CURRENTS. Circulating currents induced in conducting materials by varying magnetic fields. They are undesirable because they represent loss of energy and cause heating. Eddy currents are kept at a minimum by employing laminated construction for the iron cores of transformers, a.f.

EDISON BASE. The standard screw base used for ordinary electric light bulbs in this country.

EFFECTIVE CURRENT. That value of alternating current which will cause the same heating effect as a given value of direct current. For sine wave alternating currents, the effective value is approximately seven-tenths of the peak value.

EFFICIENCY. The ratio of energy output to energy input, usually expressed as a percentage. A perfect electrical device would have an efficiency of 100%.

ELECTRALLOY. A soft iron alloy used for radio chassis construction.

ELECTRICAL METALLIC TUBING. Thin-walled light-weight steel tubing used similarly to rigid conduit for carrying and protecting insulated electric wires.

ELECTRICAL TRANSCRIPTION. A disc recording of a complete program, as contrasted with a phonograph record which ordinarily contains only a single musical selection. Transcriptions are made to permit broadcasting of a particular program at any desired time by any number of stations.

ELECTRIC EYE. Popular expression for a cathode ray tuning indicator tube

used in modern radio receiving sets. Consists of a fluorescent screen with a dark sector which varies in direct proportion with the strength of the incoming signal. Also used in connection with photoelectric cells.

ELECTRIC FIELD. A region in space surrounding a charged object. Lines drawn to represent the direction in which the electric field will act on other charged objects are called electric lines of force. A moving electric field, such as that associated with electrons in motion or with a radio wave, is always accompanied by a moving magnetic field.

ELECTRICITY. A general term used when referring to the energy associated with electrons at rest or in motion.

ELECTRODE. An essential part inside a vacuum tube, such as the cathode, the various grids and the anode. Also, the plates of a primary cell, secondary cell or electrolytic condenser.

ELECTRODYNAMIC LOUD-SPEAKER. A dynamic loudspeaker in which the constant magnetic field is produced by an electromagnet. The coil of this electromagnet is known as the field coil.

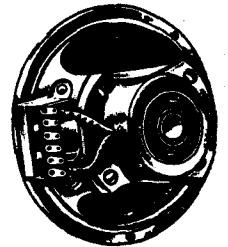

ELECTROLYTE. The liquid or chemical paste which is used between the electrodes of a dry cell storage battery or electrolytic condenser.

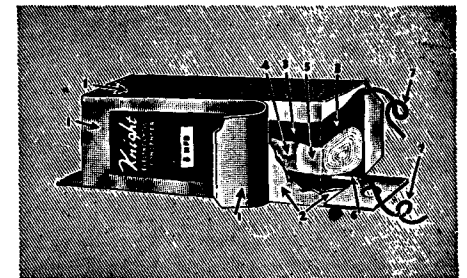

ELECTROLYTIC CONDENSER
1. Cardboard container
2. Wax-impregnated inner liner
3. Pure wax filler.
4. Etched aluminum foil.
5. Cellulose separator.
6. Terminal lead.
7. Insulated push-back leads.

ELECTROLYTIC CONDENSER. A fixed condenser in which the dielectric is a thin film of gas formed on the surface of one aluminum electrode by a liquid or paste electrolyte.

ELECTROMAGNET. A coil of wire, usually wound on an iron core, which produces a strong magnetic field when current is sent through the coil.

ELECTROMOTIVE FORCE. Voltage.

ELECTRON. A small active particle of negative electricity. Some electrons are closely associated with atoms of matter, while others, called free electrons, move readily between atoms under the influence of electric or magnetic fields. It is the movement of electrons through a conductor which constitute an electric current.

ELECTRON EMISSION. The ejection of electrons from the surface of a material into surrounding space due to

- causes. In a thermionic vacuum tube, electron emission from the cathode is produced by heat from the filament.
- ELECTRON GUN.** In a cathode-ray tube or television picture tube, the cathode, the control grid and the first and second anodes; these being the parts that produce the electron beam and direct it against the fluorescent screen.
- ELECTRONIC CONTROL.** The control of a machine or device by apparatus employing electron tubes.
- ELECTRONICS.** A broad field of electricity covering work with all types of apparatus employing electron tubes for industrial applications. Radio and television are major branches of the electronic field.
- ELECTRON TUBE.** Any partly-evacuated, completely-evacuated or gas-filled tube used to control the flow of electrons in a circuit. Vacuum tubes, phototubes, mercury vapor rectifier tubes, cathode ray tubes are all electron tubes.
- ELECTROPHORUS.** An insulating disc and a metallic plate which, when placed together and the disc electrified by friction, produce opposite electric charges on the two elements when separated.
- ELECTROSCOPE.** An instrument for detecting the presence of an electric charge, or for determining the polarity of electric charges.
- ELECTROSTATIC CAPACITY.** The ability to receive and retain an electric charge. The capacity of a condenser, measured in microfarads or farads. Capacitance or permittance. The symbol is C.
- ELEMENT.** One of the ninety-three known basic forms of matter which make up the universe. The term is also used to refer to the important parts of a device; thus, the cathode, grid and plate would be called the elements of a triode vacuum tube.
- E.M.F.** Electromotive force or voltage.
- ENAMELED WIRE.** Wire coated with an insulating layer of baked enamel.
- ENERGY.** The ability to do work, or to cause movement against an opposing force when utilized in suitable equipment. Energy exists in bodies that are in motion, in bodies such as springs that are in a strained position, in electromotive force, in chemicals, and in heat. Energy existing in one form may be changed to energy existing in other forms; as when chemical energy in a battery changes to electromotive force.
- ENVELOPE.** The glass or metal housing of a radio tube.
- EQUALIZING SIGNAL.** The portion of a television signal that insures that the two fields making up one frame start at the correct positions on the picture area of the picture tube at the receiver.
- ESCUTCHEON.** The ornamental wood, metal or plastic framework for a radio dial, tuning indicator or other panel-mounted part in a radio receiver or amplifier.
- ETHER.** The medium which is supposed to fill all space, and through which radio, heat, and light waves are supposed to travel. Its existence has not yet been definitely proved.
- EXCITER.** A small generator for supplying direct current to the field windings of an alternator. Sometimes refers to an oscillator.
- EXPLOSION-PROOF.** Enclosed in a case which is capable of withstanding an explosion of a specified gas or vapor within it, and of preventing the ignition by sparks, flashes or explosions of that gas or vapor surrounding the enclosure.

F

F. Frequency.

F. Fahrenheit. Scale of temperature.

FACSIMILE. A system of radio communication in which photographs, drawings, handwriting, and printed matter of any kind are transmitted to receivers which feed into facsimile recorders.

FACSIMILE RECORDER. An instrument which reproduces on paper the illustration, writing or printed matter being transmitted by a facsimile system.

FADING. An essentially regular rise and fall due to variations in transmission conditions along the path taken by the radio waves from the transmitting station to the receiver.

FAHRENSTOCK CLIP. A spring-type terminal to which a temporary connection can readily be made.

FAHRENHEIT. The temperature-measuring system generally used in the United States, in which 32 degrees is the temperature of melting ice and 212 is the temperature of boiling water at sea level.

FARAD. The basic unit of capacity, but too large for practical use. The microfarad, equal to one millionth of a farad, is a more practical unit for radio work. An even smaller unit, the micro-microfarad, is also used in radio; it is equal to one millionth of a microfarad.

F.C.C. Federal Communications Commission. A commission appointed by the President of the United States and given licensing and regulating authority on matters dealing with wire and radio communication in the United States and its possessions.

FEEDBACK. Transfer of energy from one point in an electrical system to a preceding point, such as from the output back to the input.

FEEDER. Any conductors of a wiring system between the service equipment, or the generator switchboard of an isolated plant, and the overcurrent devices that protect branch circuits.

FIDELITY. The faithfulness with which part or all of an electrical system delivers an exact reproduction of the input signal wave form.

FIELD. The effect produced in surrounding space by an electrically charged object, by electrons in motion, or by a magnet.

FIELD. 1. Magnetic or electromagnetic field; the space in which appear the magnetic lines of force around a magnet or an electromagnet. 2. Electrostatic field; the space between two opposite electric charges, in which ap-

pear electrostatic lines of force. 3. Television field; one travel of the scanning beam over the picture image area in the television camera. There are two fields per frame.

FIELD COIL. In an electrodynamic loudspeaker, the coil which produces the constant-strength magnetic field.

FIELD FREQUENCY. In television systems employing interlaced scanning, this term refers to the number of times per second the frame area is fractionally scanned.

FIELD MAGNET. The permanent magnet or electromagnet which supplies a magnetic field in a generator, motor or other electrical equipment.

FILAMENT. The resistance wire through which filament current is sent in a vacuum tube to produce the heat required for electron emission. When electron emission is from the surface of the filament wire itself, the filament is also serving as the cathode. When the filament merely supplies heat to a separate cathode electrode, we have a heater-type or indirectly-heated tube.

FILAMENT CIRCUIT. The complete circuit over which filament current flows from the A battery, filament winding or other filament voltage source to the filaments of radio tubes and pilot lamps.

FILAMENT CURRENT. The current supplied to the filament of a vacuum tube for heating purposes.

FILAMENT VOLTAGE. The voltage value which must be applied to the filament terminals of a vacuum tube in order to provide the rated value of filament current.

FILAMENT WINDING. A separate secondary winding provided on the power transformer of a radio receiver or other a.c.-operated apparatus for use as a filament voltage source.

FILTER. A resistor, coil, condenser or any combination of these parts which is used to block or attenuate alternating currents at certain frequencies while allowing essentially unimpeded flow of currents at other frequencies or of direct current. Thus, the filter in a radio power pack is a coil, condenser and resistor combination which receives a pulsating direct current having many a.c. components, but delivers an essentially pure and constant direct current.

FILTER CHOKE. A coil used in a filter system to pass low frequency currents or direct current while limiting or blocking the flow of higher-frequency alternating or pulsating currents.

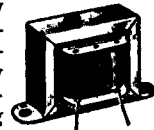

FILTER CONDENSER. A condenser used in a filter system to permit passage of higher-frequency currents while limiting or blocking the flow of lower-frequency currents and direct current.

FIRST AUDIO STAGE. The first stage in the audio amplifier of a radio receiver. Audio signals are fed into this stage by the detector of a t.r.f. receiver, and by the second detector of a superheterodyne receiver.

FIRST DETECTOR. That stage in a superheterodyne receiver in which the incoming modulated r.f. signal and the r.f. signal from the local oscillator are combined to produce the i.f. signal.

FITTING. A part such as a bushing or locknut which is intended to perform some mechanical function, rather than electrical, in a wiring system.

FIXED CONDENSER. A condenser having a definite capacity value which cannot be adjusted.

FIXED RESISTOR. A resistor having a definite ohmic value which cannot be adjusted.



FLEXIBLE METAL CONDUIT. A hollow tube formed by spirally wound metallic strips, within which are placed insulated electric wires for protection and support.

FLOURESCENT LAMP. A form of lamp which emits visible light when fluorescent material (phosphors) on the inside of the lamp tube are struck by streams of electrons passing between electrodes in the ends of the tube.

FLOURESCENT SCREEN. A coating of chemical material which glows when bombarded by electrons. In a cathode ray tube, the coating is on the inside surface of the evacuated glass envelope of the tube.

FLUX. The magnetic lines of force in a magnet or in a magnet and its magnetic field. The flux, in magnetism, is similar to the current in electric circuits, since both terms refer to a flow.

FLYBACK PERIOD. A period or interval during which the scanning beam in the television camera is extinguished or is blanked while the controls which move the beam return to the conditions at which the following trace is to be made over the picture image.

F.M. Frequency modulation. Also written as f-m or FM.

FOCUSING CONTROL. In a cathode ray oscilloscope or television system, the control which adjusts the size of the visible spot produced at the screen by the electron gun in a cathode ray tube.

FOUR-WAY SWITCH. A switch used in a circuit that permits a single lamp to be controlled from any of three or more positions. The switch has four terminals which alternately are joined together in different pairs.

FRAME. In television, one complete scanning of every part of the field of view being transmitted.

FRAME. One complete scanning of the image in the television camera tube. One frame consists of two fields.

FRAME FREQUENCY. In television, the number of times per second the frame area is completely scanned.

FRAMING CONTROL. In television, a general term applying to any of the control knobs used for adjusting the centering, width and height of the reproduced image.

FREE ELECTRONS. Those electrons which are free to move between the atoms of a material when acted upon by electric or magnetic forces.

FREQUENCY. The number of complete cycles per second which an electric current, a sound wave or a vibrating object undergoes. Frequency in cycles is equal to the velocity divided by the wavelength.

FREQUENCY CONVERTER. A circuit or device which changes the frequency of an alternating current. Thus, the oscillator and mixer-first detector stages make up the frequency converter of a superheterodyne receiver.

FREQUENCY DISTORTION. A type of distortion which occurs when a circuit or device amplifies or transmits unequally the different frequencies it is handling.

FREQUENCY MODULATION. A relatively new system of radio broadcasting perfected by Major E. H. Armstrong, in which the amount of deviation in frequency above and below the resting frequency is at each instant proportional to the amplitude of the sound wave being transmitted, and the number of complete deviations per second above and below the resting frequency is equal to the frequency of the sound wave being transmitted.

Advantages of this system include almost complete freedom from atmospheric and man-made interference, as well as little or no interference between stations, thereby permitting the transmission of a much greater volume range and a wider audio frequency range than is possible with amplitude modulation. One disadvantage is the necessity of employing ultra-high carrier frequencies, at which the range of a station is limited to approximately 100 miles.

FREQUENCY RESPONSE. A rating or graph which expresses the manner in which a circuit or device handles the different frequencies falling within its operating range. Thus, the frequency response of a loudspeaker may be specified as being essentially flat, or uniform between 100 and 6000 cycles.

FULL-WAVE RECTIFIER. A radio tube or other device which rectifies an alternating current in such a way that both halves of each input a.c. cycle appear in the pulsating rectified output. A full-wave rectifier tube contains two separate diode sections, one passing current during one alternation, and the other passing current during the opposite half cycle.

FUSE. A strip or wire of metal which, when it carries an electric current greater than the capacity or rating of the fuse, will become so heated by the excess of current as to melt or burn out. The fuse is connected in the circuit to be protected against overcurrent, and melts to open the circuit when overcurrent exists in the circuit. A fuse sometimes is called a cutout. Other overcurrent protective devices include automatic relays and circuit breakers.

G

GAIN. In an amplifier stage or system, the ratio of output voltage, current or power to input voltage, current or power. Usually expressed in decibels.

GALENO. Lead sulphide, a shiny bluish gray mineral often used as the crystal in a crystal detector.

GANG SWITCH. Two or more rotary switches mounted on the same shaft and operated by a single control.

GANG TUNING CONDENSER. Two or more variable tuning condensers

mounted on the same shaft and operated by a single control.

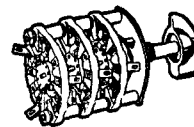

GANG SWITCH
(ROTARY)

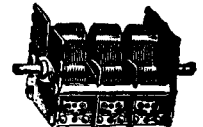

GANG TUNING
CONDENSER

GASEOUS TUBE. An electronic tube into which a small amount of gas or vapor is admitted after the tube has been evacuated. Ionization of the gas molecules during operation of the tube gives greatly increased current flow.

GAS-FILLED LAMP. An incandescent lamp whose bulb is filled with nitrogen and argon gases which permit operating the filament at higher temperatures than in vacuum lamps.

GENERATOR. A rotating machine which converts mechanical energy into electrical energy. Also, a radio device or circuit which develops an a.c. voltage at a desired frequency when energized with d.c. or low frequency a.c. power.

GETTER. An alkali metal introduced into a vacuum tube during manufacture and vaporized after the tube has been evacuated, to absorb any gases which may have been left by the vacuum pump. The silvery deposit on the inside of the glass envelope of a tube, usually near the tube base, is the result of getter vaporization.

GHOST IMAGE. In television, an undesired duplicate image appearing a fraction of an inch to one side of the desired image, due to reception of a reflected signal along with the signal coming directly from the television station. The remedy involves using a directional receiving antenna adjusted so it will receive signals coming over only one path.

GLASS-TYPE TUBE. A vacuum tube or gaseous tube having a glass envelope or housing.

GLOW LAMP. A gaseous tube having a glass envelope through which can be seen a glow due to ionization of the molecules of gas. Neon gas gives a red glow, mercury vapor gives blue, and argon gas gives a light purple glow. Also called glow tube.



GRAM. The unit of weight in the metric system. One pound is equal to 453 grams.

GRID. An electrode mounted between the cathode and the anode of a radio or electronic tube to control the flow of electrons from cathode to anode. The grid electrode is usually either a cylindrical-shaped wire screen or a spiral of wire through which electrons can readily move.

GRID BIAS. Another term for C bias, which is the voltage used to make the control grid of a radio tube negative with respect to the cathode.

GRIP CLIP. A spring clip used to make an easily removable connection to the cap terminal located at the top of some radio tubes.

GRID CONDENSER. A small fixed condenser inserted in the grid circuit of a vacuum tube.

GRID LEAK. A resistor of high ohmic value, used to connect the control grid to the cathode in a grid leak-condenser detector circuit.

GRID-LEAK-CONDENSER DETECTOR. A type of detection in which a.f. potentials developed across a grid resistor by the flow of grid current through that resistor result in plate current changes at the desired audio frequencies. This type of detector is identified by the presence of a grid leak and grid condenser in the grid circuit.

GRID RETURN. The lead or connection which provides a path for electrons from the grid circuit or C bias battery to the cathode.

GRILLE. An arrangement of wood or metal bars placed across the front of the loudspeaker in a radio receiver for protective purposes and to enhance the design of the cabinet.

GRILLE CLOTH. A loosely woven cloth stretched behind the loudspeaker grille of a radio receiver to keep dust and other foreign matter out of the loudspeaker diaphragm. Sound waves travel unimpeded through this cloth.

GROMMET. A special washer, made of rubber or other insulating material, used to prevent a wire from touching the sides of a chassis hole through which the wire is run.

GROUND CLAMP. A metal strap or clamp used for making a good electrical connection to a ground rod or grounded pipe. The clamp has a screw terminal or soldering lug to which the ground wire of a radio receiver can readily be attached.

GROUND WIRE. The wire used to connect the ground terminal of a radio receiver or transmitter to a ground clamp or other grounded object.

GROUND WAVES. Radio waves which travel along the surface of the earth instead of going up into the sky.

GROUNDING CONDUCTOR. A wire or other conductor used to connect electrical equipment or one of the conductors in a wiring system with ground or with a grounding electrode buried in the earth.

GUTTER. A trough or recess for wire leads and wire splices in a cabinet or box.

GUY WIRE. A wire used to brace the mast or tower of a transmitting or receiving antenna system.

H

HALF-WAVE RECTIFIER. A radio tube or other device which converts alternating current into pulsating direct current by allowing current to pass only during one half of each alternating current cycle. A half-wave rectifier tube contains only one diode section.

HARMONIC. A multiple of any particular frequency. Thus, the second harmonic of a fundamental frequency would be equal to two times that fundamental frequency.

HARMONIC DISTORTION. Another name for wave form distortion.

HARTLEY OSCILLATOR. A vacuum tube oscillator circuit identified by a tuned circuit which employs a tapped winding connected between the grid

and plate of the vacuum tube, with the tap going to the cathode.

HAZARDOUS LOCATIONS. Locations in which special types of electrical equipment and devices are required to insure safety. Places where flammable materials are stored other than in original containers, where dust may become combustible or explosive, where dust and dirt collect in such quantities as to cause overheating, and where combustible materials are handled, manufactured, stored or used.

HAZELTINE LICENSED. Radio apparatus which uses Hazeltine patents under a licensing agreement with the Hazeltine Corporation.

HEADPHONE. A small telephone receiver, held against an ear by a clamp passing over the head, used for private reception of radio programs or for reception of signals which are too weak to provide loudspeaker volume. Headphones are usually used in pairs, one for each ear, with the clamping strap holding them both in position.



HEATER. A filament used in a vacuum tube only for the purpose of supplying heat to an indirectly heated cathode.

HEAVISIDE LAYER. A layer of ionized gas which scientists believe exists in the region between 50 and 400 miles above the surface of the earth, and which reflects radio waves back to earth under certain conditions. Also called the Kennelly-Heaviside layer.

HELIX. A coil formed by a single-layer spiral winding, usually with no iron in the core space.

HENRY. The practical unit of inductance.

HIGH-FIDELITY RECEIVER. A receiver capable of reproducing audio frequencies in a range from 50 to about 8,000 cycles or wider without serious distortion. A receiver which approaches the goal wherein the reproduced program cannot be distinguished from the original studio program.

HIGH-FREQUENCY TRIMMER. In a superheterodyne receiver, the trimmer condenser which controls the calibration of a tuning circuit at the high-frequency end of a tuning range.

HOLD CONTROLS. In a television receiver, the two manually-adjusted controls which adjust the natural oscillating frequencies of the oscillators employed in the horizontal and vertical sweep circuits.

HOOK-UP. A diagram giving circuit connections for a radio receiver, amplifier or transmitter.

HORIZONTAL OSCILLATOR. In a television receiver, the oscillator that uses the horizontal synchronizing and blanking signals to produce voltages which, when amplified, operate the deflecting plates or coils in the picture tube.

HOT-CATHODE TUBE. A vacuum or gaseous tube in which the cathode is heated to provide electron emission.

HOT WIRE METER. A current-indicating meter whose pointer is allowed to move across the dial when a wire inside the meter is heated and expanded by the measured current flowing through this wire.

HOWL. An undesirable audio frequency oscillation occurring in a radio or amplifier system, due either to electrical or acoustic feedback.

HUM. A low and constant audio frequency, usually either 60 to 120 cycles, heard in the background of a received radio program. A defective filter condenser in an a.c. power pack is a common cause of hum in a radio receiver.

HYDROMETER. A weighted hollow bulb with an extended graduated stem which, when partially immersed in a liquid, sinks to a level such that the specific gravity of the liquid is indicated on the stem.

HYSTERESIS. In the iron or steel of a magnetic circuit energized by a coil winding, the lag of magnetic flux behind the rate at which current increases in the coil, and the lag in reduction of flux behind the rate at which coil current decreases. There is a similar effect or similar lag of electrostatic flux in a dielectric with changes of voltage which produce the flux.

I. Commonly used to designate current.

ICONOSCOPE. A form of cathode-ray tube used in the camera of a television transmitter. The tube contains a mosaic or an area covered with photosensitive globules on which the image is focused, also a conductive plate and a collector which receives electrons emitted by the sensitive globules.

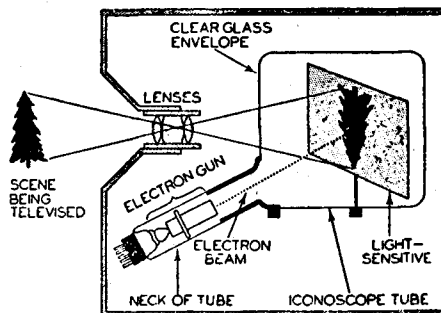

I.F. Intermediate frequency.

IMAGE. An interfering signal whose frequency is twice the I.F. frequency of receiver.

IMAGE DISSECTOR. A cathode ray television pickup tube. Construction and operating principles are different from those of the iconoscope, but serves essentially the same purpose of converting a scene into corresponding electrical impulses.

IMAGE RATIO. The ratio of the strength of a signal to its image. Used to indicate selectivity of a receiver.

IMAGE RECONSTRUCTOR. The cathode ray tube used in a television receiver to convert received signals to original picture.

IMPEDANCE. The total opposition which a radio part or circuit offers to the flow of alternating or pulsating direct current at a particular frequency. Impedance is a combination of resistance and reactance, and is measured in ohms.

IMPULSE. A momentary increase in the current or voltage in a circuit.

INCANDESCENT LAMP. An electric lamp in which light is produced by the white-hot temperature of the filament in which heat is produced by current flowing against the resistance of the filament.

INDOOR ANTENNA. A receiving antenna system located entirely inside a building, either under a rug, around the walls, or in the attic.

INDUCED VOLTAGE. A voltage produced in a circuit by changes in the number of magnetic lines of force which are linking or cutting through the conductors of the circuit.

INDUCTANCE. That property of a coil or other radio part which tends to prevent any change in current flow. Inductance is effective only when varying or alternating currents are present; it has no effect whatsoever upon the flow of direct current. Inductance is measured in henrys.

INDUCTION. Electromagnetic induction is the production of an emf or voltage in a conductor which moves through a magnetic field and cuts across the lines of force, or when the magnetic field is moved across the conductor. Magnetic induction is the production of magnetism in a piece of iron or steel by magnetic lines of force from another magnet.

INDUCTION MOTOR. An alternating-current motor in which energy from stationary windings is transferred to conductors on the revolving rotor by electromagnetic induction, and in which the rotor receives no current through any conductive connections such as brushes and a commutator or slip rings.

INDUCTIVE COUPLING. A form of coupling in which energy is transferred from a coil in one circuit to a coil in another circuit by induction. Magnetic lines of force produced by the flow of current through one coil cause an a.c. voltage to be induced in the other coil.

INDUCTIVE REACTANCE. Reactance due to the inductance of a coil or other part in an alternating current circuit. Inductive reactance is measured in ohms, and is equal to the inductance in henrys multiplied by the frequency in cycles, times the number 6.28; inductive reactance therefore increase with frequency.

INSTANTANEOUS VALUE. The voltage, current or other value at some instant of time in a circuit wherein the voltage or current is continually changing, as with alternating current.

INSTRUMENT TRANSFORMER. A current transformer, which see.

INSULATION. Any material which has a sufficiently high electrical resistance to permit its use for separating one electrical circuit, part or wire from others. Cotton, silk, baked enamel, mica, porcelain, rubber and bakelite are a few of the common insulating materials used in radio.

INSULATOR. A part made of insulation in a form suitable for supporting electrical conductors or for separating them electrically from other conductors.

INTELLIGENCE SIGNAL. Any signal which conveys information, such as voice, music, code, television pictures, facsimile photographs, diagrams, written and printed matter, etc.

INTERCOMMUNICATION SYSTEM. An amplifier system which provides two-way communication between two or more rooms in a building. Each station in the system contains a microphone and loud-speaker, usually combined as a single dynamic unit; a headphone or telephone receiver is sometimes provided also for private reception of messages. The stations may be connected to each other by wire cables, or may receive and transmit messages through the electric wiring system in the building.

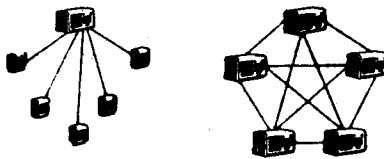

INTERCOMMUNICATION SYSTEMS

INTER-ELECTRODE CAPACITY. The capacity which exists between two electrodes in a vacuum tube. Although this is usually a very low value, it becomes extremely important when tubes are operated in ultra-high frequency circuits.

INTERFERENCE. Noises or undesired radio programs which interfere with reception of a desired radio program.

INTERFERENCE FILTER. A device used between source of interference and a radio to attenuate or eliminate noise. Generally consists of a capacity and inductance which offers a high impedance to noise impulses.

INTERLACED SCANNING. In television, a type of scanning to which every other line of the image is scanned during one downward travel of the scanning beam, and the remaining lines are scanned during the next downward travel of the scanning beam.

INTERMEDIATE FREQUENCY. In a superheterodyne receiver, the frequency to which all incoming carrier signals are converted before being fed into the intermediate frequency amplifier.

INTERMEDIATE FREQUENCY AMPLIFIER. That section of a superheterodyne receiver which is designed to amplify signals with high efficiency at a predetermined frequency called the intermediate frequency of the receiver.

INTERMEDIATE FREQUENCY TRANSFORMER. A transformer used at the input and output of each i.f. amplifier stage in a superheterodyne receiver for coupling purposes and for providing selectivity.



INTERMEDIATE LAMP-HOLDER. A lampholder having a nominal screw diameter of 21/32 inch.

INTERMITTENT RECEPTION. A type of radio receiver trouble in which the receiver performs normally for a time, then becomes dead or distorts the programs, with the process repeating itself.

INTERNAL RESISTANCE. The resistance of conductors inside some electrical equipment or device; the resistance of the device or equipment measured between its terminal connections. The resistance of conductors through which currents flow inside a battery, generator or motor.

INTERNATIONAL MORSE CODE. The code used universally for radio

telegraphy, and also used for wire telegraphy in some European countries. It is also known as the Continental Code.

INVERSE FEEDBACK. Intentional negative feedback or degeneration, introduced in an amplifier or single vacuum tube stage for the purpose of reducing distortion, thereby permitting greater power output.

INVERTED L ANTENNA. The conventional antenna used for broadcast reception, having a long horizontal portion suspended between insulators, with the single wire lead-in connected to one end of the horizontal portion.

ION. An atom or molecule which has fewer or more electrons than normal. A positive ion is one which has lost electrons, and a negative ion is one which has acquired more electrons than normal.

IONIZATION. An action whereby atoms or molecules of gas in an electronic tube are converted into electrically charged ions which are attracted by charged electrodes. Ionization makes a gaseous tube more conductive than an equivalent vacuum tube.

IR DROP. A technical expression sometimes used to designate the voltage drop developed across a resistance by the flow of current through the resistance.

IRON-CORE COIL. A coil having iron inside its windings. The iron is usually in the form of laminations, but it may also be pulverized iron mixed with a binding material.

IRON-CORE TRANSFORMER. A transformer in which iron makes up part or all of the path for magnetic lines of force traveling through the transformer windings.

ISOLANTITE. A high-quality insulating material used in the construction and mounting of radio parts, particularly those employed in ultra-high frequency circuits.

ISOLATED PLANT. A private electrical installation deriving energy from its own generator driven by a prime mover such as a gas engine.

ISOLATING SWITCH. A switch intended only for disconnecting its circuit from a source of power after the circuit has been opened and current stopped by some other means.

J

JACK. A plug-in type spring terminal widely used in radio apparatus for temporary connections. A connection is made to a jack simply by plugging into it a probe or plug attached to a flexible insulated wire or cable. Some jacks have extra contacts which are opened or closed when the probe is inserted, thereby giving automatic switching action.

JAMMING. Intentional transmitting of radio waves in such a way as to interfere with reception of signals from another station.

JOULE. A unit of electrical energy or of work, equal to the energy transferred by a power rate of one watt continuing for one second. The work done by sending one ampere of elec-

tricity through a resistance of one ohm for one second.

JUMPER. A wire used to connect two points together temporarily.

K

K. Letter used to designate the cathode of a radio tube.

KC. Kilocycle.

KENNELLY-HEAVISIDE LAYER. A layer of ionized gas supposed to exist in the region between 50 and 400 miles above the surface of the earth. It reflects radio waves back to earth under certain conditions, making possible long-distance reception.

KEY. A lever-type switch designed for rapid opening and closing of a circuit during transmission of code signals.



KILOCYCLE. One thousand cycles but commonly interpreted as 1,000 cycles per second.

KILOWATT. One thousand watts.

KINESCOPE. A cathode ray tube developed by the Radio Corporation of America and used in television receivers for the purpose of reproducing on a screen the scene originally televised.

KIRCHOFF'S CURRENT LAW. A fundamental electrical law which states that the sum of all the currents flowing to a point in a circuit must be equal to the sum of all the currents flowing away from that point.

KIRCHOFF'S VOLTAGE LAW. A fundamental electrical law which states that the sum of all the voltage sources acting in a complete circuit must be equal to the sum of all the voltage drops in that same circuit.

KNIFE SWITCH. A switch in which one or more flat metal blades, each pivoted at one end, serve as the moving parts. The blades are usually of copper; when the switch is closed, they make contact with flat gripping spring clips and complete the circuit.

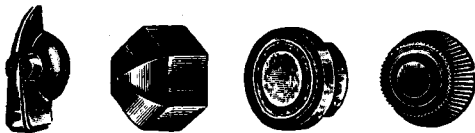

TYPES OF RADIO KNOBS

KNOB. A radio part, usually round but sometimes having a pointer or other position-indicating means, which is attached to the end of a control shaft to make it easier to rotate the shaft with the fingers.

KW. Kilowatt.

L

L. The letter commonly used on circuit diagrams and in formulas to designate an inductance or coil.

LAMINATED. A type of construction widely used for the cores of iron core transformers, choke coils, electromagnets, motors and generators. It involves building up the desired shape of core with thin strips of a magnetic

material such as soft iron or silicon steel.

LAMPHOLDER. A screw shell device for receiving the screw base of an incandescent lamp bulb or other part with a similar screw base, and for making electrical connections to the part thus held. Often called a lamp socket.

LAPEL MICROPHONE. A small microphone which can be attached to a lapel or pocket by means of a clip.

LAYOUT. A diagram indicating the placement of parts on a panel or chassis.

LEAD-ACID BATTERY. A storage battery in which the plates for the cells have active materials of sponge lead and lead peroxide, and in which the electrolyte liquid is a mixture of sulphuric acid and water. The most common type of storage battery.

LEAD-IN. A wire which serves to connect the outdoor signal pickup portion of an antenna system with the antenna terminal of a radio receiver.

LEAD-IN INSULATOR. A porcelain tube inserted in a hole drilled through an outer wall or window frame of a house. The lead-in wire of the antenna is run through this tube.

LEAKAGE. Undesirable flow of current through or over the surface of an insulating material. This term is also used to describe magnetic flux which wanders off into space without doing useful work.

LEAKAGE FLUX. That portion of the total magnetic flux which does not link all of the turns of wire in a coil or transformer and is consequently wasted.

LEAKAGE RESISTANCE. The resistance of a path taken by leakage currents. Thus, the leakage resistance of a condenser is the normally high resistance which it offers to the flow of the direct current.

LEYDEN JAR. A form of condenser consisting of a glass jar which acts as the dielectric, coated inside and outside with tin foil which acts as the conductive plates.

LIGHTING OUTLET. In a building wiring system an outlet intended for direct connection of a lampholder, a lighting fixture, or a cord that carries a lampholder.

LIGHTNING ARRESTER. A protective device used to sidetrack directly to ground a discharge of lightning which strikes a radio receiving or transmitting antenna.

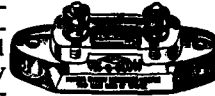

LIMITER. In a frequency modulation radio receiver, a tube circuit which eliminates any amplitude modulation which may have affected the carrier wave and leaves only the frequency modulation.

LINE CORD. A two-wire cable terminating in a two-prong plug, used to connect a radio receiver to an a.c. or d.c. wall outlet. Sometimes this cord also includes a resistance wire used for the purpose of reducing the line voltage to the value required by the series-connected filaments of the tubes.

LINE FILTER. A device inserted between the line cord plug of a radio receiver and the power line to block noise signals which might otherwise enter the receiver from the power line. It contains one or more choke coils and condensers.



LINE OF FORCE. A path through space between magnetic poles or electrostatic poles, along which acts the magnetic force or electrostatic force as shown by lines drawn between the poles on a sketch.

LINE VOLTAGE. The voltage existing at a wall outlet or other terminals of a power line system. In the United States, the line voltage is usually between 115 and 120 volts, but may vary at times as much as five volts above and below these limits.

LOAD. Lamps, motors, heaters, or any other energy-consuming or power-consuming equipment connected to a battery, generator or a circuit supplying power and energy. The load might be measured in watts, watt-hours, ohms of resistance, amperes, volts, or any other unit which would indicate the size or magnitude of the load.

LOG. A list of radio stations. A record of stations with which a radio transmitter has been in communication; amateur radio operators are required by law to keep this log. A detailed record describing the program being broadcast each minute of the operating day by a broadcast station. A record of the meter readings which are required by law to be taken at regular intervals in a broadcast transmitter and in certain other types of transmitters.

LOGGING. Making a record of the exact dial setting at which a radio station is received, or making a written record of any other essential data in connection with radio equipment.

LOKTAI TUBE. A small-size glass radio tube having a special base, construction which locks the tube firmly in the corresponding special 8-prong loktai socket. Loktai tubes are used chiefly in midget a.c.-d.c. receivers and in auto radios.

LONG WAVES. Wave lengths longer than the longest broadcast band wave length of 545 meters. Long waves correspond to frequencies between about 20 kilocycles and 550 kilocycles.

LOOP ANTENNA. An antenna consisting of one or more complete turns of wire. It may be built into a radio receiver cabinet or separately mounted, and is usually tuned to resonance by a variable condenser. Loop antennas are used extensively in radio direction-finding apparatus.

LOSSES. Energy which is dissipated before it accomplishes useful work.

LOUDSPEAKER. A device for converting audio frequency signals into sound waves.

LOUVER. A type of loudspeaker grille construction in which sloping slats or equivalent parts of a molded plastic cabinet hide the loudspeaker yet allow sound waves to emerge unhindered. Also spelled louvre.

LOW-FREQUENCY PADDER. In a superheterodyne receiver, a semi-adjustable condenser which is placed in series with the oscillator tuning circuit.

to control the calibration of the circuit at the low-frequency end of the tuning range.

LOW-LOSS CONSTRUCTION. A type of radio part construction involving the use of insulating materials which maintain their insulating characteristics at high radio frequencies.

LUG. A small strip of metal placed on a terminal screw or riveted to an insulating material to provide a convenient means for making a soldered wire connection.

M

M. A letter sometimes used to indicate that a particular resistance value is to be multiplied by 1,000. Thus, 50M would mean 50,000 ohms.

MA. Milliampere.

MAGNET. A piece of iron or steel which has the property of attracting other pieces of magnetic material such as iron, and has the property of attracting or repelling other magnets.

MAGNET WIRE. Insulated copper wire in sizes commonly used for winding coils used in electro-magnetic devices such as transformers, choke coils and relays.

MAGNETIC CIRCUIT. A complete path for magnetic lines of force. It always includes the permanent magnet or electromagnet which is producing the magnetic lines of force.

MAGNETIC FIELD. A region in space surrounding a magnet or a conductor through which current is flowing.

MAGNETIC INDUCTION. The magnetizing of iron or steel by the magnetic field of a magnet which is near to or in contact with the magnetized metal.

MAGNETIC LINES OF FORCE. Imaginary lines used for convenience to designate the directions in which magnetic forces are acting throughout the magnetic field associated with a permanent magnet, electromagnet or current-carrying conductor.

MAGNETIC LOUD-SPEAKER. A loud-speaker consisting essentially of a permanent magnet, a pivoted armature which is mechanically connected to the diaphragm or cone, and a coil which is connected to the output stage of a radio receiver or other apparatus.

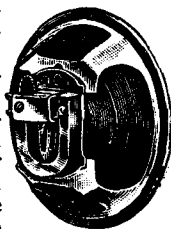

Interaction between the permanent magnetic field and that developed in the armature by the coil results in movement of the armature and production of sound waves by the diaphragm.

MAGNETIC PICK-UP. A phonograph pick-up consisting of a permanent magnet, one or two coils, an iron armature and a core structure so arranged that movement of the phonograph needle in the record groove varies the amount of magnetic flux passing through the coils, thereby inducing audio frequency voltages in the coils.

MAGNETIC FLUX. Total number of magnetic lines of force acting in a magnetic circuit.

MAGNETIC POLARITY. Identification of magnetic poles according to the

direction of lines of force; the north pole being the one at which lines issue from the magnet, and the south pole the one at which they re-enter the magnet.

MAN-MADE STATIC. High-frequency noise signals which are produced by sparking in electrical apparatus or power lines and picked up by radio receivers, with the result that buzzing and crashing sounds are heard along with a desired radio program.

MANUAL TUNING. Tuning a radio receiver to a desired station by rotating the tuning control knob by hand.

MASTER SERVICE. Service conductors and equipment for a group of buildings under one management.

MATCHING. Connecting two circuits or parts together with a coupling device in such a way that the impedance of either circuit will be equal to the impedance existing between the coupling terminals to which that circuit is connected.

MAXIMUM UNDISTORTED OUTPUT. The maximum audio power output which a radio receiver or audio amplifier will deliver without having more than 10% total harmonic distortion. Tests have shown that this amount of distortion is not ordinarily noticeable or objectionable.

MAXIMUM VALUE. The greatest value reached by an alternating voltage or current during any instant in the cycle.

MAYDAY. The international distress call for radiotelephone communication. It is derived from the French pronunciation of "M'aidez," meaning "Help me."

MC. Megacycle.

MEDIUM LAMPHOLDER. A lamp-holder having a nominal screw diameter of one inch.

MEG. Megohm.

MEGACYCLE. One million cycles per second.

MEGOHM. A resistance of one million ohms.

MERCURY. A heavy, silvery-colored metal which is liquid at ordinary room temperatures. When heated, it gives off a vapor which is highly conductive when ionized.

MERCURY VAPOR LAMP. A lamp in which a small quantity of mercury is vaporized by the heat of an electric discharge through argon gas, after which flow of current through the mercury vapor produces light.

MERCURY VAPOR RECTIFIER TUBE. A rectifier tube containing a small amount of mercury. When the filament or heater-type cathode is heated, mercury vapor is produced, and the resulting ionization of the mercury vapor molecules gives a much higher plate current than would be obtained in an equivalent vacuum type rectifier tube.

METALLIZED RESISTOR. A resistor made by depositing a thin film of high-resistance metal on the surface of a tube or rod made of glass or other insulating material. Leads are attached to opposite ends of the unit.



METAL-TYPE TUBE. A vacuum or gaseous tube having a metal envelope or housing, with electrode connections being made through glass beads fused into the metal envelope. Usually called all-metal tube.

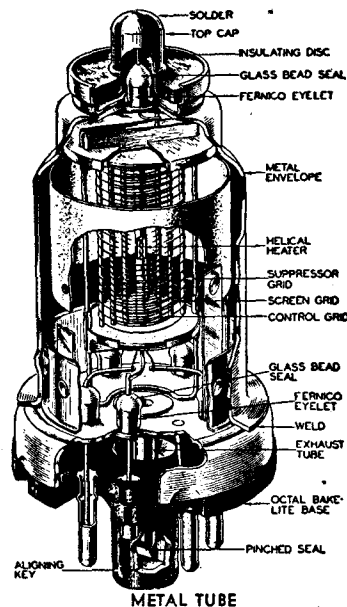

METER. The unit of length in the metric system; one meter is equal to 3.28 feet. An instrument used for making electrical measurements. A voltmeter measures voltage; an ammeter or milliammeter measures currents; a wattmeter measures power; an ohmmeter measures resistance.

MFD. Microfarad.

MH. Millihenry.

MICA. A transparent flaky mineral which splits readily into thin sheets and has excellent insulating and heat-resisting qualities. It is used extensively to separate the plates of condensers, to insulate electrode elements of vacuum tubes, and for many other insulating purposes in radio apparatus.

MICA CONDENSER. A condenser which employs sheets of mica as the dielectric material which insulates adjacent plates from each other.

MICRO. A prefix meaning one millionth.

MICROAMPERE. One millionth of an ampere.

MICROFARAD. A unit of capacity equal to one millionth of a farad. The microfarad is the capacity unit most commonly used in radio work. It is abbreviated as mfd.

MICRO-MICROFARAD. A unit of capacity equal to one millionth of a microfarad, and abbreviated as mmfd.

MICROPHONE. A device which converts sound waves into corresponding audio frequency electrical energy. It contains some form of flexible diaphragm which moves in accordance with sound wave variations. This movement, in turn, generates a minute voltage which is fed to the input of an amplifier where it is amplified many times. There are several types of microphones available, but they all operate on the above principle. **Carbon Microphone.** A microphone in which loosely packed carbon granules com-

plete the electrical circuit between two terminals. The resistance of this circuit varies in accordance with variations in the pressure exerted on the granules by the sound-actuated diaphragm. In a single-button carbon microphone, the granules are on only one side of the diaphragm. In a double-button carbon microphone the granules are on both sides of the diaphragm, giving a push-pull action which greatly increases the resistance change produced by a given diaphragm movement. **Condenser Microphone.** A microphone in which the diaphragm serves as one plate of a condenser. Sound waves move the diaphragm in and out, causing the capacity of the microphone and the current through it to vary in accordance with the sound waves. **Contact Microphone.** A microphone designed to pick up mechanical vibrations directly and convert them into electrical impulses. It is used chiefly with string, wind, and percussion musical instruments, and is simply strapped or clamped to the housing of the instrument. **Crystal Microphone.** A microphone depending upon the piezoelectric effect, or voltage produced in Rochelle salt crystals when subjected to mechanical stress such as that caused by sound waves. Two types are in use today, the sound-cell type and the diaphragm type. **Dynamic Microphone.** A microphone in which the diaphragm moves a voice coil back and forth in a constant magnetic field, causing audio currents to be induced in the coil. A small dynamic loudspeaker is often made to serve also as a dynamic microphone, particularly in two-way intercommunication systems. **Velocity or Ribbon Microphone.** A microphone in which a thin, light-weight ribbon of duralumin alloy serves as the diaphragm. This ribbon is mounted in a powerful fixed magnetic field. Audio frequency voltages are induced in the ribbon when it is moved back and forth through the magnetic field by sound waves.

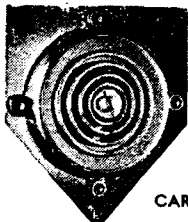

CARBON

CRYSTAL

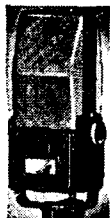

VELOCITY

DYNAMIC



crophone stand or in the microphone housing itself.

MICROPHONE BUTTON. A button-shaped container filled with carbon particles. When attached to the diaphragm of a microphone, the resistance between the terminals of the button varies in accordance with movements of the diaphragm.

MICROPHONE STAND. A table or floor-type stand used to support a microphone in a desired position.

MICROPHONE TRANSFORMER. The iron-core a.f. transformer which couples the microphone to a microphone amplifier, to a transmission line, or to the input circuit of the main audio amplifier.

MICROPHONIC. A condition in which mechanical movement of some radio part other than a microphone causes corresponding variations in circuit current. A radio tube is microphonic if a pinging sound is heard in the loudspeaker when the side of the tube is tapped with a finger; the tapping is then setting the internal elements into vibration. If sound waves from the loudspeaker are producing this vibration of tube elements, the sound will be sustained as a howl.

MIKE. A microphone.

MILLI. A prefix meaning one thousandth.

MILLIAMMETER. A measuring instrument which measures current flow in milliamperes.

MILLIAMPERE. An electric current of 1/1000 of an ampere.

MILLIHENRY. A unit of inductance equal to one thousandth of a henry.

MILLIMETER. A metric unit of length equal to one thousandth of a meter. One millimeter is approximately equal to one twenty-fifth of an inch.

MILLIVOLT. A unit of voltage equal to one thousandth of a volt.

MIXER. A control which permits combining the output signals of two or more microphones or other a.f. signal sources in any desired proportion before these signals are fed to the input of the main a.f. amplifier. Also, the stage in a superheterodyne receiver in which the incoming modulated r.f. signals are mixed with the local oscillator signals to produce the i.f. signal.

MM. Millimeter.

MOBILE STATION. A radio station operated in a movable location such as on an automobile, fire truck, railway train, ship or airplane.

MODULATED AMPLIFIER. The r.f. stage in a transmitter at which the intelligence signal is made to modulate the r.f. carrier signal.

MODULATED WAVE. A radio wave which varies either in frequency (frequency modulation) or in amplitude (amplitude modulation) in accordance with the wave form of the intelligence signal being transmitted.

MODULATION. The process of varying the frequency or the amplitude of an r.f. carrier signal in accordance with the wave form of the intelligence signal being transmitted.

MODULATOR. The final audio stage in a radio transmitter. It feeds the

intelligence signal into the modulated amplifier stage, where the signal is made to modulate the r.f. carrier signal.

MOGUL LAMPHOLDER. A lampholder having a nominal screw diameter of 1½ inches.

MOLECULE. The group of atoms which constitutes the smallest particle in which a compound or material can exist separately.

MONKEY CHATTER. Garbled speech or music heard along with a desired program. This type of interference occurs when the side frequencies of an adjacent-channel station beat with the desired station signal.

MONOSCOPE. A special type of cathode ray tube which produces television picture signals corresponding to the design or picture which has been printed on its screen. This tube is used in television picture signal generators to provide a satisfactory signal source for television receiver test purposes during those times when no television station is on the air.

MORSE CODE. A system of dot and dash signals used in the transmission of messages by radio or wire telegraphy. The International Morse Code (also called the Continental Code) is used universally for radio telegraphy, while the American Morse Code is used only for wire telegraphy.

MOSAIC. The photosensitive globules on their insulating mounting in the tube or Iconoscope of the television camera. The camera lens system focuses the image on the area of the mosaic.

MOTOR. A machine which converts electrical energy into mechanical energy.

MOTORBOATING. Regeneration occurring at audio frequencies in a radio receiver or audio amplifier, resulting in put-put-put sounds resembling those made by a motorboat.

MOTOR-CIRCUIT SWITCH. A switch that will open the maximum operating overland current of a motor, the switch being rated in horsepower which is the same as that of the motor.

MOTOR-GENERATOR. An electric motor directly connected to one or more generators for the purpose of converting a power line voltage to other desired voltages or frequencies.

MOTOR STARTER. A hand-operated or magnetically operated contactor or heavy-duty switching device for opening and closing the circuit feeding a motor or motors as the motors are stopped and started.

MOVING COIL METER. A current-actuated electric meter consisting of a permanent magnet between the poles of which is suspended a wire coil through which flows all or part of the current to be measured. The coil is mounted between end bearings and to it is attached the indicating pointer. The coil and pointer are moved by reaction between the magnetic fields of the permanent magnet and of the current-carrying coil.

MU. Amplification factor.

MULTI-

METER. A test instrument having provisions for measuring voltages and currents, as well as resistance. It usually consists of one or sometimes two meters provided with the necessary number of scales, and a range-selecting switch which places a meter in the correct circuit for a particular measurement. Also known as a multitester, multiple-purpose tester or voltohm-milliammeter.

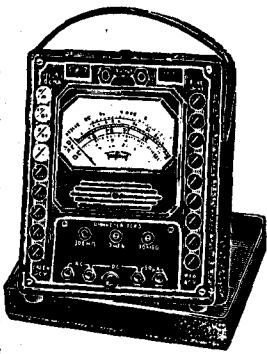

MULTIPLE CONNECTION. Same as parallel connection, which see.

MULTIPLIER. A resistor used in series with a voltmeter to increase the range of the meter.

MULTIPOLAR. Having more than one magnetic pole. Usually refers to an electric machine having more than two poles, the two-pole types being called bipolar or two-pole.

MUTUAL INDUCTION. Production of a varying or alternating emf in one circuit by movement across its conductors of field lines arising in another nearby circuit in which the current is varying.

N

NATURAL MAGNET. A lodestone, which see.

NEEDLE. That part of a phonograph pick-up which converts the variations in the record grooves into mechanical movements which are in turn converted into audio frequency signals by the pick-up element. The needle must be carefully shaped to follow faithfully the high-frequency variations in the grooves without causing excessive record wear.

NEGATIVE. Referring to a potential less than another potential, or to a potential less than that of the earth. A point toward which current flows in parts of a circuit external to the source.

NEGATIVE BIAS. The use of a voltage which makes the control grid of a radio tube negative with respect to the cathode.

NEGATIVE CHARGE. The electrical condition of a body on which are more than the normal quantities of negative electrons, so that the body has more negative electricity than has an uncharged or neutral body.

NEGATIVE FEEDBACK. Degeneration, causing a reduction in signal strength.

NEGATIVE MODULATION. In television, a method of transmission in which a decrease in scene illumination causes an increase in the radiated power of the transmitter.

NEON. A pure gas sometimes used in electronic tubes. It produces a characteristic red glow when ionized.

NEON GLOW LAMP. A neon-filled gaseous tube having a glass envelope through which can be seen the characteristic red glow of neon when ionization occurs during operation of the tube.

NETWORK. An electric circuit in which the parts cannot be classified as connected in series, in parallel, or in series-parallel, but in which the connections are of some special nature suited to the purpose for which the circuit is to be used.

NEUTRAL. Having electric or electrostatic potential intermediate between the potentials of other associated parts in a circuit; positive with reference to some parts while negative with reference to others. Sometimes refers to zero potential, neither positive or negative.

NEUTRALIZATION. A term used in radio to describe any process which balances out or prevents an undesirable effect such as oscillation.

NEUTRALIZING TOOL. A small screwdriver or socket wrench, constructed partly or entirely from non-metallic materials, and used for making neutralizing or aligning adjustments in radio receivers. It eliminates the body capacity effects which would affect the accuracy of the adjustments if an ordinary metal wrench or screwdriver were used.

NICHROME. An alloy of nickel, iron and chromium which has a high resistance per unit volume and is capable of withstanding high temperatures. It is used extensively in the construction of wire-wound resistors, as well as in the heating elements of soldering irons and other electrical heating appliances.

NOISE. In radio, a term used chiefly in connection with interfering sounds heard along with desired programs.

NOISE FILTER. A device which is inserted between a wall outlet and the power cord plug of a radio receiver to block noise interference which otherwise might enter the receiver.

NOISE LIMITER. A special radio circuit which limits the effects of interfering noises by cutting off all noise peaks which are stronger than the highest signal peak being received.

NOISE SILENCER.

A special vacuum tube circuit which can be introduced into superheterodyne receivers to reduce the effects of static and man-made interference noises. Its chief value is in short wave communication receivers.

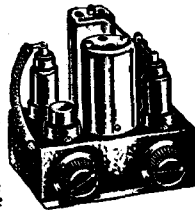

NOISE-REDUCING ANTENNA SYSTEM. An antenna system in which the only part capable of picking up signals is the antenna proper, this being erected high enough to be out of the noise-interference zone. The lead-in is a special shielded cable or twisted two-wire line which can pass through the interference zone without picking up noise signals.

NON-CONDUCTOR. Any material which offers very high opposition to the flow of electricity. An insulating material.

NON-MAGNETIC. Materials such as glass, wood, copper, brass and paper which are not affected by magnetic fields.

NON-METALLIC SHEATHED CABLE. Wire or cable enclosed within and protected by a covering of insulating compounds and fabric braids in layers providing fair mechanical strength. Used for some building wiring where this cable is permitted.



OBSOLESCENCE-FREE. Not liable to become out of date because of new developments or new inventions. A term applied particularly to tube testers and other test instruments.

OCTAL BASE. A type of tube socket base having eight equally-spaced prongs and a central aligning key. When some of the prongs are not needed, they are omitted without changing the positions of the remaining prongs.

OCTAL GLASS-TYPE TUBE. A glass tube having an octal base.

OHM. The unit of electrical resistance. The resistance of a device is one ohm when a d.c. voltage of one volt will send a current of one ampere through that device. The Greek letter omega (ω or Ω) is commonly used to represent ohm.

OHMIC DROP. Potential difference due to flow of direct current through resistance.

OHMIC VALUE. The resistance in ohms which a part or circuit offers to the flow of direct current.

OHMMETER. A test instrument which measures and indicates directly the resistance of a part or the resistance between any two points in a circuit. It consists essentially of a milliammeter in series with a suitable d.c. voltage and suitable series or shunt resistors.

OHM'S LAW. A fundamental electrical law which expresses the relationship between voltage, current, and resistance in a direct current circuit, or the relationship between voltage, current and impedance in an a.c. circuit. The three forms of the law in each case are given below, in which E is the pressure in volts, I is current in amperes, R is resistance in ohms and Z is impedance in ohms.

D.C. FORMS

$$E = I \times R$$

$$I = E \div R$$

$$R = E \div I$$

A.C. FORMS

$$E = I \times Z$$

$$I = E \div Z$$

$$Z = E \div I$$

OHMS-PER-VOLT. A sensitivity rating for meters. It is obtained by dividing the resistance in ohms of any meter range by the full scale voltage reading of the meter at that range. The higher the ohms-per-volt rating, the more sensitive is the meter.

OPERATOR. A person whose duties include the adjustment, maintenance and operation of radio transmitting equipment.

OSCILLATION. A condition whereby high-frequency currents are generated in a circuit.

OSCILLATOR. The stage in radio receiver, transmitter or other apparatus in which a vacuum tube and associated parts generate alternating current en-

ergy when fed with direct current energy. Thus, the oscillator stage in a superheterodyne receiver generates an r.f. signal of the correct frequency to produce the i.f. carrier signal when mixed with an incoming station signal. In a transmitter, the oscillator stage generates the carrier frequency of the station or a frequency equal to some definite fraction of the assigned frequency.

OSCILLOGRAPH. A test instrument which records photographically the wave form of a varying current or voltage.

OSCILLOSCOPE. A test instrument which shows visually on a screen the wave form of a varying current or voltage.

OUTLET. A set of terminals from which electric power may be obtained. Thus, power at the a.c. line voltage may be obtained from a wall outlet in a building connected to an a.c. power system.

OUTPUT. The useful electrical energy delivered by a radio receiver, a.f. amplifier, electrical generator, or any other signal or power source.

OUTPUT IMPEDANCE. The impedance as measured between the output terminals of a radio device, receiver or amplifier at a definite frequency or at a predominant frequency in the audio range which the device is a handle. For maximum efficiency, the load impedance should match or be equal to this output impedance.

OUTPUT METER. A meter connected to the output of a receiver or amplifier for the purpose of measuring variations in output signal strength.

OUTPUT STAGE. The final stage in a receiver or a.f. amplifier. In a radio receiver, the output stage feeds the loudspeaker directly. In an a.f. amplifier, the output stage may feed into one or more loudspeakers, a transmission line, or a cutting head in the case of a sound recording system.

OUTPUT TRANSFORMER. An iron-core a.f. transformer used to provide efficient coupling between the output stage of a radio receiver or a.f. amplifier and its load.

OUTPUT TUBE. A tube designed for use in the output stage. It is a power amplifier tube, whereas the other tubes in a receiver are usually voltage amplifier tubes.

OVERCURRENT DEVICE. A protective device, such as a fuse or circuit breaker, which acts almost simultaneously to open a circuit when current in that circuit exceeds a certain predetermined value.

OVERLOAD DEVICE. A protective device, such as a thermally operated or heat-operated switch, that acts to open a circuit when an excessive load and excessive current have continued for long enough to bring temperature of the circuit wires nearly to the danger point.

P

P. A letter used to designate power, the plate electrode of a tube, or the primary winding of a transformer.

P.A. Public address.

PADDER. In a superheterodyne receiver, the trimmer condenser placed in series with the oscillator tuning circuit to control the receiver calibration at the low-frequency end of a tuning range.

PANEL. A sheet of metallic or non-metallic material on which the operating controls of a radio device such as a receiver, transmitter, or p.a. amplifier are mounted.

PANELBOARD. An enclosed panel or panels carrying buses, switches, over-current devices and other control elements in various combinations for the control of lighting, heating or power circuits or relatively small capacity such as used in individual buildings or sections of buildings.

PAPER CONDENSER. A fixed condenser employing foil plates separated by paraffined or oiled paper.

PARALLEL CONNECTION. A connection of two or more circuits or parts between the same terminals of a source or current-supply circuit so that the same voltage difference is applied to all parts so connected and so that the current through each is proportional to the overall voltage and the resistance of the individual parts. The total current is equal to the sum of the currents in all the connected circuits or parts, and the total resistance or the effective resistance of all the parts in parallel is less than the individual resistance of any one of them.

PARALLEL RESONANT CIRCUIT. A tuning circuit consisting of a coil and condenser connected in parallel. At resonance, it offers a high impedance, so that a large value of signal voltage is developed across it at the frequency to which it is tuned.

PEAK. The maximum instantaneous value of a varying voltage or current.

PEAK VALUE. Same as maximum value, which see.

PENTODE. A vacuum tube having five electrodes. Ordinarily these will be the cathode, control grid, screen grid, suppressor grid and anode.

PERIOD. The length of time required for one complete cycle of alternating current or voltage. As an example, the period for 60 cycles per second is 1/60 second.

PERMANENT MAGNET. A piece of steel in which the particles are so lined up that the piece remains magnetized and continues to have a magnetic field without help from any external magnetism.

PERMANENT MAGNET DYNAMIC SPEAKER. A moving coil speaker with its field supplied by a permanent magnet.

PERMEABILITY. A measure of the ease with which magnetic flux or magnetic lines of force may be established in a magnetic circuit. The ratio of the number of flux lines produced by an electromagnet coil having a core of iron or steel to the flux produced by the same coil with no core other than air. The reciprocal of reluctance.

PERMEABILITY TUNING. Tuning of radio by means of adjustable iron-core inductance in place of tuning condenser.

PHASE. In alternating current or voltage, the portion of a cycle or period

through which the current or voltage has passed since going through zero value at the beginning of the cycle or period. The position of the current or voltage is specified in degrees, of which 360 compose a complete cycle or period. See Lag, Lagging Current, and Lead.

PHILLIPS SCREW. A screw having an indented cross in its head in place of a slot.

PHONE. A headphone.

PHONOGRAPH. A device for converting mechanical vibrations into sound waves. **Electrical Phonograph.** A phonograph in which the motor derives its power from an electrical source. **Mechanical Phonograph.** A phonograph utilizing a hand-wound type of mechanical motor.

PHONOGRAPH CONNECTION. A set of two terminals sometimes provided at the back of a radio receiver for making connections to a phonograph pick-up. The terminals connect to the input of the a.f. amplifier. This connection permits use of the entire audio amplifier and loudspeaker to reproduce phonograph records.

PHONOGRAPH OSCILLATOR. An r.f. oscillator arranged for modulation by the output of a phonograph pick-up, so that the resulting modulated r.f. signal can be fed to the antenna and ground terminals of a radio receiver. This permits using the entire receiver (rather than just the a.f. amplifier) for amplifying and reproducing phonograph records.

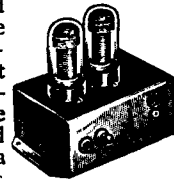

PHONOGRAPH PICK-UP. A device which converts variations in the grooves of a phonograph record into corresponding audio signals. It consists essentially of a needle which converts record groove variations into mechanical movements, and a crystal, dynamic or photoelectric system which converts these mechanical movements into the audio signals.



PHOSPHOR. Any fluorescent material used for the screen in a cathode-ray tube, an X-ray viewing screen, or a fluorescent lamp. The phosphor becomes luminous when struck by a stream or beam of electrons.

PHOTOCELL. An evacuated or gas-filled bulb containing two electrodes, one of which is coated with substances which readily emit electrons when struck by visible light. With a voltage difference applied to the electrodes, current through the cell is proportional to the light reaching the light-sensitive electrode.

PHOTOCONDUCTIVE CELL. A device utilizing the property of selenium by which its electrical resistance varies with changes of visible light striking the selenium or the cell.

PHOTOELECTRIC CELL. Any device in which visible light varies the flow of electric current through the cell, thus forming a unit in which changes of light produce corresponding changes of electric current.

PHOTOTUBE. A photocell, which see.

PHOTOVOLTAIC CELL. A device containing two electrodes immersed in a liquid electrolyte, capable of producing an emf proportional to the visible light that falls upon one of the electrodes. It is essentially a primary voltaic cell whose output varies with changes of light.

PICTURE ELEMENT. In a television system, the smallest portion of a picture or scene which is individually converted into an electrical signal and transmitted.

PICTURE FREQUENCY. In television, the number of complete pictures which are scanned and transmitted in one second.

PICTURE TUBE. In a television receiver, the cathode-ray tube on whose screen is reproduced the scene being scanned at the television transmitter.

PIEZO-ELECTRIC EFFECT. A property of crystals of quartz and some other substances by which their form or dimensions are varied by application of potential differences to opposite faces. The original dimensions and manner of cutting of the crystal determine the frequency of applied voltage at which the crystal is resonant and vibrates most freely, this being the frequency which will be maintained within very narrow limits in a suitable resonant circuit containing the crystal.

PIGTAIL. A flexible connection between a stationary terminal and a part or terminal which has a limited range of motion.

PILOT LAMP. A small lamp mounted on the panel of a radio receiver to illuminate the tuning dial, or mounted on the panel of other radio apparatus to indicate when the apparatus is turned on. 

PLASTIC. A general term used in connection with any of the black or colored materials used for molding radio receiver cabinets, control knobs, tube bases, sockets, and the insulating portions of many other radio parts. It is an excellent insulating material and has a natural smooth glossy surface which requires no finishing or polishing operations after molding.

PLATE. The anode in a radio tube. It is usually at a high positive potential with respect to the cathode, and therefore attracts the electrons emitted by the cathode.

PLATE CIRCUIT. A circuit including the plate voltage source and all other parts connected between the cathode and plate terminals of a radio tube.

PLATE CURRENT. The current flowing through the plate circuit of a radio tube and between the plate and cathode inside the tube. The electrons which make up the plate current always flow in the direction from the cathode to the plate.

PLATE SUPPLY. The voltage source used in a vacuum tube circuit to place the plate at a high positive potential with respect to the cathode. The plate supply voltage is always higher than the actual plate voltage, because of the voltage drops across resistance in the plate circuit.

PLATE VOLTAGE. The d.c. voltage existing between the plate and cathode terminals of a radio tube.

PLUG. A connecting device at the end of a flexible cord, used for making an instantly-removable connection to a corresponding terminal jack or outlet.

PLUG FUSE. A fuse so mounted as to screw into its holder.

PLUG-IN COIL. A coil having as its terminals a number of prongs arranged to fit into a socket mounted on the radio chassis. With this arrangement, the tuning range of a receiver or transmitter can be changed simply by pulling out one coil and inserting another in the socket. 

POLARITY. In a radio part or circuit, the quality of having two opposite charges, one negative and the other positive. In a magnetic circuit or part, the quality of having two opposite poles, one North and the other South.

POLE. One end of a magnet. One electrode of a battery.

POLICE CALLS. Broadcasts or calls made by police radio stations. Many modern single-band receivers are capable of picking up police radio stations operating on frequencies between 1626 kc. and 1712 kc. (just beyond the high-frequency end of the broadcast band).

POLARIZATION. Reduction of the terminal voltage of a cell, due to formation of hydrogen gas on the surfaces of the cell electrodes and to the accompanying counter-emf produced in the cell.

POLARIZED. 1. A polarized bell or relay is one whose armature is a permanent magnet and which operates in accordance with the direction of current through its windings. 2. Marked, colored, or otherwise identified for the correct connection of positive and negative wires, grounded and ungrounded wires, or other conductors.

PORTABLE APPLIANCE. An appliance to which current is furnished through a flexible cord and attachment plug, permitting the appliance to be moved and connected to various sources.

POSITIVE. A term used to describe a terminal having fewer electrons than normal, so that it attracts electrons in seeking to return to its normal state. Thus, electrons flow into the positive terminal of a voltage source.

POSITIVE CHARGE. The electrical condition of a body which has less than the normal quantity of negative electrons, so that the body has less negative electricity than one which is uncharged or is neutral.

POSITIVE FEEDBACK. Regeneration, causing an increase in signal strength.

POSITIVE MODULATION. In television, a method of transmission in which an increase in scene illumination causes an increase in the radiated power of the transmitter.

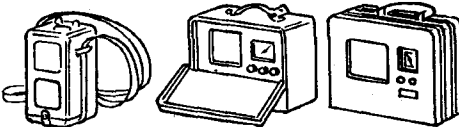

PORTABLE RECEIVERS

PORTABLE RECEIVER. A completely self-contained radio receiver

having the loudspeaker, all necessary batteries, and a loop antenna built into a compact carrying case. Terminals are sometimes provided for external antenna and ground connections.

POTENTIAL. A characteristic of a point in an electric circuit determined by its electric charge in comparison with the charge at some other reference point, thus making the point considered more positive or more negative than the reference point.

POTENTIOMETER. A resistance unit having a rotating contact arm which can be set at any desired point on the resistance element. The total available voltage is applied to the fixed end terminals of the resistance element, and the output circuit is connected between the movable contact and one end terminal. Rotating the movable contact thus varies the proportion of the total voltage which is transferred to the output circuit. The volume control of a receiver or p.a. amplifier is generally a potentiometer. 

POWER. The rate at which electrical energy is delivered and consumed. Electrical power is measured in watts.

POWER AMPLIFIER STAGE. An audio amplifier stage which is capable of handling a relatively large amount of audio power without distortion. An r.f. amplifier stage in a transmitter which serves primarily to increase the power of the r.f. carrier signal.

POWER FACTOR. The ratio of the voltage and current, or volt-amperes, that do useful work in an alternating-current circuit or alternating-current equipment to the total voltage and current, volt-amperes, flowing in the circuit. In circuits containing much inductance or much capacitance in addition to their resistance the total current is more than the current that produces useful power, consequently such circuits have relatively low power factors. In circuits containing only resistance all the current and voltage do useful work, consequently the ratio is one-to-one or is unity, this being the highest possible power factor.

POWER FACTOR CORRECTION. The addition of capacitance to an alternating-current circuit containing a great deal of inductance, so that the capacitive reactance balances out a large portion of the inductive reactance, thus lessening the amount of current that does no useful work and making a higher power factor for the circuit. Inductance might similarly be added to a circuit containing excessive capacitance.

POWER LEVEL. The amount of electrical power passing through a given point in a circuit. Power level can be expressed in watts, in decibels, or in volume units.

POWER LEVEL INDICATOR. An a.c. voltmeter which is calibrated to read in terms of audio power level.

POWER PACK. The power supply unit of a radio receiver, amplifier, transmitter, or other radio apparatus. Its function is to convert the available power line or storage battery voltage to the values required by filament, grid and plate circuits.

POWER TRANSFORMER. An iron-core transformer having a primary winding which is connected across the a.c. power line, a high-voltage secondary winding for the power pack rectifier tube, and one or more low-voltage secondary windings which supply the required a.c. voltages to the tube filaments.

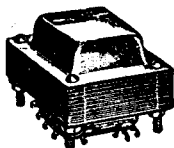

POWER OUTPUT TUBE. A radio tube especially designed for use in the a.f. output stage of a radio system. It is capable of handling much greater current than the ordinary amplifier tube, and hence delivers high output power.

PRESELECTOR. That circuit or r.f. amplifier stage in a superheterodyne receiver which amplifies the incoming modulated r.f. signal before it is converted to the i.f. signal by the oscillator-mixer-first detector section.

PRI. Primary.

PRIMARY. First in order of time, placement, development or importance.

PRIMARY CELL. A voltaic cell or battery cell in which, when current is produced, the chemicals of the cell elements are consumed or changed to such forms that they cannot be restored to their original active condition by sending a reverse current through the cell, thus making the cell useless after having delivered a certain number of ampere-hours of electricity.

PRIMARY WINDING. The input winding of a transformer. It can be identified by the fact that r.f., a.f. or power line alternating current or pulsating d.c. is sent through this winding.

PROTON. One of the positively charged particles which, together with electrons (negatively charged particles), make up the structure of an atom.

PUBLIC ADDRESS AMPLIFIER. An audio amplifier capable of supplying sufficient audio power to loudspeakers for adequate sound coverage of public gatherings.

PUBLIC ADDRESS SYSTEM. A complete system for reproducing voice and speech with adequate volume for large public gatherings. It includes one or more microphones, a powerful audio amplifier with suitable power supply, and a sufficient number of loudspeakers to give coverage of the auditorium, stadium or other large space. Most installations also include a phonograph which may or may not be of the automatic record changer type.

PULSATING CURRENT. A current which changes in value but not in direction. It can be considered as a direct current combined with a smaller value of alternating current.

PULSE. A momentary sharp change in a current or voltage.

PUSH-BACK HOOP-UP WIRE. Tinned copper hook-up wire covered with a loosely braided cotton insulation which can be pushed back from the end of a wire length with the fingers to expose sufficient bare wire for a connection. Radio men use this type of wire almost exclusively for experimental and repair work.

PUSH-BUTTON TUNER. A tuning unit which automatically tunes a radio re-

ceiver to a station when the button assigned to that station is pressed. In electrical automatic push-button tuning, the button actuates switches which connect a set of pre-adjusted trimmer condensers into the receiver tuning circuits. In electromechanical automatic push-button tuning, the button controls the starting and stopping circuits of a small motor which rotates the regular gang tuning condenser of the receiver. In mechanical automatic push-button tuning, pressure on the button is transferred by a lever or cam system into a force which rotates the gang tuning condenser to the correct position for the desired station.

PUSH-PULL CIRCUIT. A two-tube audio output circuit so arranged that both tubes operate simultaneously and their individual a.f. plate currents add in the common load to give twice the output of a single tube. This circuit arrangement has the added advantage that it balances out all even harmonics which would otherwise cause distortion.

PUSH-PULL TRANSFORMER. An iron-core a.f. transformer designed for use in a push-pull amplifier circuit. If it is the input transformer, it will have a center-tapped secondary winding. If it is the output transformer, it will have a center tapped primary winding.

PUSH-PUSH CIRCUIT. A two-tube audio output circuit so arranged that the tubes operate alternately into a common load.



Q FACTOR. A rating used to express certain characteristics of coils and resonant circuits. It is obtained by dividing reactance by ohmic resistance.

Q SIGNAL. One of the three-letter abbreviations in the International List of Abbreviations, used to represent complete sentences in radio telegraphy. When the question form of the sentence is intended, the code signal for an interrogation mark is sent after the abbreviation. Thus QRM means "I am being interfered with," and QRN? means "Are you being interfered with?"

QUARTZ-CRYSTAL. A thin slab about the size of a half-dollar, cut from a natural crystal of the mineral quartz and carefully ground to a thickness which will make it vibrate at the desired natural frequency when supplied with energy. It is used as the master carrier frequency source in the crystal oscillator stage of a radio transmitter.

R

R. Resistance.

RACEWAY. Any enclosure designed for and used only for holding wires, cables or bus-bars; includes all types of conduit, whether of metal or of insulating material, and all similar wire channels.

RADIATION. The process wherein the transmitting antenna system of a radio station converts the modulated r.f. output of the transmitter into radio waves which travel away from the station through space.

RADIATION PATTERN. A diagram showing how well an antenna system

radiates or picks up radio waves in various directions.

RADIO. Communication by means of radio waves. Also, a receiving set capable of picking up radio waves and reproducing the intelligence they convey. This intelligence may consist of speech, music, code signals, writing, printed matter, diagrams, photographs, motion pictures, actual scenes, etc. In space radio, which is the conventional form, radio waves are transmitted through space. In wired radio, the radio waves are guided by conductors.

RADIO BEACON. A stationary radio transmitter which sends out special identifying signals continuously. Radio receivers on ships at sea and on aircraft in flight can tune to a radio beacon to determine their direction and position with respect to the beacon location.

RADIO BROADCASTING. A one-way transmission of voice and music to anyone within receiving range of the radio station.

RADIO COMPASS. A radio direction finder used chiefly in marine and aircraft radio stations for navigational purposes.

RADIO CONTROL. The control of moving objects such as airplanes, automobiles, ships, torpedoes, etc., by means of signals transmitted over radio waves from the transmitter location to special radio receiving equipment in the object being controlled.

RADIO FREQUENCY. Any frequency in the radio spectrum above the highest audible frequency, which is about 20,000 cycles. This term is also used in connection with radio parts designed for use at frequencies higher than the audio frequency range. Abbreviated r.f.

RADIO FREQUENCY AMPLIFIER. A vacuum tube amplifier stage to provide amplification at radio frequencies. In a t.r.f. receiver, all stages ahead of the detector are r.f. amplifier stages. In a superheterodyne receiver, the amplifier stage sometimes used ahead of the first detector (in the pre-selector) is an r.f. amplifier stage.

RADIO FREQUENCY CHOKE. A choke coil designed to have high impedance at radio frequencies, so that it limits or blocks the flow of r.f. currents.

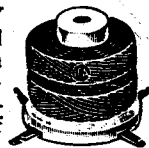

RADIO FREQUENCY TRANSFORMER. An air-core or pulverized iron-core transformer used in r.f. circuits.

RADIO METAL LOCATOR. A radio instrument which indicates the presence of metal within its operating range by a change in meter reading or a change in a tone signal heard in headphones. Used for determining positions of buried pipe lines, buried metal objects, metal objects concealed in the clothes of prisoners, metal objects imbedded in logs about to be sawed, deposits of metallic minerals, etc.

RADIO METEOROGRAPH. A combination meteorograph and radio transmitter carried aloft by an unmanned gas-filled rubber balloon and so designed that it will transmit back to earth radio signals which can be interpreted in terms of the pressure, tem-

perature and humidity at regular intervals during the ascent of the balloon into the stratosphere. When the balloon bursts, the instrument is lowered to earth by a parachute.

RADIO PROSPECTING. Use of radio equipment to locate mineral or oil deposits.

RADIO RECEIVER. An instrument which amplifies radio frequency signals, separates the r.f. carrier from the intelligence signal additionally in most cases, then converts the intelligence signal back into the original sound waves.

RADIOSONDE. A radio meteorograph.

RADIO TELEGRAPHY. Radio communication by means of the Internal Morse Code.

RADIO TELEPHONE TRANSMITTER. A transmitter capable of sending voice and music, as contrasted to a radiotelegraph transmitter which can send only code.

RADIO TELEPHONY. Two-way voice communication between two or more stations by means of radio waves.

RADIOTRICIAN. A trained radio serviceman.

RADIO WAVE. A combination of electric and magnetic fields varying at a radio frequency, and capable of traveling through space at the speed of light. It is produced by feeding the output of a radio transmitter to the transmitting antenna, and may carry modulation.

RAINTIGHT. So constructed or protected that exposure to a beating rain will not cause entrance of water into the enclosure.

R.C.A. LICENSED. Manufactured under a licensing agreement which permits use of patents controlled by the Radio Corporation of America.

REACTANCE. Opposition offered to the flow of alternating current by the inductance or capacity of a part. Reactance is measured in ohms, and depends upon the frequency of the alternating current as well as upon the electrical value of inductance or capacity. A condenser has capacitive reactance, and a coil has inductive reactance. The letter X is used to designate reactance.

RECEPTACLE. A device which holds or supports and at the same time makes electrical connections to a lampholder, lamp base, cord plug, or other attachment device.

RECEPTACLE OUTLET. An outlet equipped with one or more receptacles intended to receive attachment plugs or cord plugs, not with receptacles of the screw type.

RECORD PLAYER. A motor-driven turntable and a crystal or magnetic phono pick-up used for converting a phonograph record into audio frequency signals. These signals must be fed into the audio section of a radio receiver or into a separate audio amplifier for additional amplification before they can be reproduced as sound waves by a loudspeaker. When the amplifier and loudspeaker are built into the same cabinet with the record player, the combination is generally called an electric phonograph.

RECORDER. An instrument which makes a permanent record of a varying electrical signal. Thus, code messages are recorded on paper tape by a code recorder. Music and voice are recorded on discs or other materials by a sound recorder. Pictures and printed matter transmitted by radio are reproduced on paper by a facsimile recorder.

RECTIFIER. A device which changes an alternating current into a pulsating direct current. It may be a vacuum tube, gaseous tube, crystal, vibrator or copper-oxide device.

RECTIFIER METER. A moving coil direct-current meter equipped with a rectifier which changes alternating current or voltage to be measured into direct current or voltage which will operate the meter and cause it to indicate.

REGENERATION. A method of securing output from an amplifier by feeding a part of the amplifier output back to the amplifier input in such a way that reinforcement of the input signal is obtained. With this arrangement, a signal may pass through the same amplifier over and over again, with an increase in strength each time.

REGENERATION CONTROL. A rheostat, potentiometer, or variable condenser which is used in a regenerative receiver to control the amount of signal which is fed back from output to input in the regenerative detector stage.

REGENERATIVE DETECTOR. A vacuum tube detector in which international feedback of r.f. energy from the plate circuit to the control grid circuit produces regeneration.

REGENERATIVE RECEIVER. A radio receiver which employs controlled regeneration to increase the amplification provided by a vacuum tube stage (usually the detector stage).

RELAY. An electromagnetic device which permits control of current in one circuit by a much smaller current flowing in another circuit.

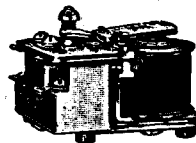

REMOTE CONTROL. Operation of radio transmitting or receiving equipment from a remote point.

RESISTANCE. The opposition which a device or material offers to the flow of direct or alternating current. The opposition which results in production of heat in the material carrying the current. Resistance is measured in ohms, and is usually designated by the letter R.

RESISTANCE COUPLING. A type of coupling in which a resistor and condenser provides a path for signal energy between two circuits.

RESISTIVITY. The resistance in ohms which a unit cube of a material offers to the flow of electric current.

RESISTOR. A radio part which offers resistance to the flow of electric current. Its electrical size is specified in ohms or megohms, (one megohm equals 1,000,000 ohms). A resistor also has a power-handling rating in watts, indicating the amount of power which can safely be dissipated as heat by the resistor.

RESONANCE. The condition in a circuit whose inductive reactance and capacitive reactance are equal, allowing them to completely balance or neutralize each other and leaving only the resistance of the circuit to oppose flow of current in it.

RESONANT FREQUENCY. The frequency which produces resonance in a coil-condenser tuning circuit. In a series resonant circuit, the largest current flow occurs at the resonant frequency. In a parallel resonant circuit, the largest voltage is developed across the circuit at the resonant frequency.

RESTING FREQUENCY. The assigned carrier frequency of a radio station which employs the frequency modulation system of broadcasting. The resting frequency is radiated only during intervals when no sound waves are being transmitted.

RETENTIVITY. A measure of the ability of a permanent magnet to retain its magnetic strength.

RETRACE PERIOD. The time during which the blanked scanning beam in a television tube returns to its starting point on the field.

R.F. Radio frequency.

RHEOSTAT. A resistance unit which can be varied in ohmic value so as to control the flow of current in the circuit of which it is a part.

RIGID METAL CONDUIT. Piping or heavy tubing of mild steel having pipe-thread ends and used with similarly threaded fittings for the enclosure and support of insulated wires in an electrical system.

RIM-DRIVE. A method of driving a phonograph or sound recorder turntable with a rubber-covered wheel which is in contact with the rim of the turntable. The wheel is powered by an electric motor.

RIPPLE. An alternating current component which is present in the output of a d.c. voltage supply such as a power pack or d.c. generator.

R.M.A. Radio Manufacturers Association, an organization of leading manufacturers in the radio industry. Its work involves standardizing sizes and designs of radio parts, standardizing of color markings on parts (such as the R.M.A. color code for resistors and condensers) and standardizing of radio terms and definitions.

R.M.A. COLOR CODE. A standard method of designating resistor values by colored markings. The code is given at the back of this book.

R.M.S. Root mean square value, which is the effective value of an alternating current. It corresponds to the equivalent direct current value which will produce the same heating effect. Unless otherwise specified, alternating current values are always r.m.s. values.

ROENTGEN RAYS. Same as X-rays.

ROSIN-CORE SOLDER. Solder which has as its core the correct amount of rosin flux for effective radio soldering work. The rosin is released automatically as the solder is applied to the heated joint.

ROTOR. In a generator, motor or other electric machine having a rotating member, the member that rotates. A word used chiefly when referring to alternating-current machines.

ROTOR PLATES. The movable plates of a variable condenser. They are usually connected directly to the metal frame of the condenser.

ROTARY BEAM ANTENNA. A highly directional short wave receiving or transmitting antenna system mounted on a high pole or mast in such a way that it can be rotated to any desired positions either manually or by an electric motor drive.

ROTARY SWITCH. A rotary switch which is operated by rotating its control knob.



R.P.M. Revolutions per minute.

S

S. A letter sometimes used to designate the secondary winding of a transformer.

SAPPHIRE. A gem used in the tips of high-grade phonograph needles and in cutting needles used with sound recorders.

SCALE. A series of marks printed on a flat surface over which the pointer of a meter moves. The value of the mark directly behind the pointer corresponds to the meter reading.

SCANNING. In television, the process by which an image of a scene to be transmitted and reproduced has its lights and shades changed into corresponding changes of voltage and current for each small element or area of the scene, these electrical changes being transmitted and then reconverted into lights and shades at the receiver.

S.C.C. Single cotton covered insulation on a wire.

S.C.E. Single cotton covering over an enamel insulating layer on a wire.

SCHEMATIC DIAGRAM. A diagram which shows electrical connections of a radio device by means of symbols which are used to represent the radio parts.

SCRATCH FILTER. A filter circuit used in connection with a phonograph pick-up to block those frequencies at the higher end of the audio range at which needle scratch is most prominent.

SCREEN. In a television picture tube or a cathode-ray tube, the internal coating of fluorescent material which is made to glow by the electron beam in reproducing pictures or lines.

SCREEN GRID. An electrode mounted between the control grid and plate of a vacuum tube for the purpose of reducing the capacity between these two electrodes.

SCREEN GRID TUBE. A vacuum tube having a screen grid. It may be a tetrode (four-element tube) or a pentode (five-element tube). In the latter case, it is more often called a screen grid pentode.

SCREEN GRID VOLTAGE. The d.c. voltage which is applied between the screen grid and the cathode of a vacuum tube to make the screen grid highly positive with respect to the cathode.

SEC. Secondary.

SECONDARY CELL. A d.c. voltage source which is capable of storing elec-

trical energy. When exhausted, it can be recharged by sending direct current through it in the reverse direction. Each cell of an ordinary storage battery is a secondary cell.

SECONDARY EMISSION. Emission of electrons from a cold electrode when it is hit or bombarded by high-speed electrons.

SECONDARY WINDING. The coil or winding of a transformer which is connected to the load, the coil from which power leaves the transformer.

SECONDARY WINDING. Any of the output windings in a transformer.

SELECTIVITY. The degree to which a radio receiver is capable of reproducing signals of one station while rejecting signals from all other stations.

SELF-BIAS. Referring to a vacuum tube stage which produces its own grid bias voltage. Plate current flowing through a resistor in series with the cathode lead produces across this resistor the voltage drop used for grid bias purposes. Also called automatic C bias.

SELF-INDUCTANCE. The property of a circuit whereby any change of current flowing in the circuit produces a counter emf that opposes the change that is taking place, an emf that tends to prevent an increasing current from increasing, and tends to prevent a decreasing current from decreasing. Measured in henrys. The symbol is *L*.

SENSITIVITY. In electrical measuring instruments, a measure of the current, voltage, or power required to operate the meter itself and to cause its indicator to move. The less the required power the higher is the sensitivity.

SERIES CONNECTION. A connection in which the same current must flow through all of the series-connected parts. When dry cells or batteries are connected in series so that their voltage add, the minus terminal of one cell must be connected to the plus terminal of the next cell.

SERIES-PARALLEL. Descriptive of a circuit or part of a circuit in which some parts or elements are connected together in series, with these series groups connected together in parallel; or parts connected in parallel and the groups in series.

SERIES RESONANT CIRCUIT. A circuit in which a coil and condenser are connected in series, and have values such that the inductive reactance of the coil will be equal to the capacitive reactance of the condenser at the desired resonant frequency. At resonance, the current through a series resonant circuit is a maximum.

SERIES WINDING. In a motor, generator or other electric machine, a winding in which flows all the current that enters or leaves the machine.

SERVICE. The conductors and equipment which deliver electric energy and power from a transformer, feeder or main of a public service distribution system to the wiring system of a building or premises in which the power is utilized.

SERVICE AREA. The region around a broadcast station in which its signal

strength is strong enough to insure satisfactory reception at all times.

SERVICE ENTRANCE. Descriptive of equipment and conductors used at the point where building wiring connects to the service.

SETTING. The current at which or in excess of which a circuit breaker or other adjustable protective device will operate to open its circuit.

SG. Letters used to designate the screen grid electrode of a vacuum tube.

SHADED POLE MOTOR. An alternating-current induction motor which is self-starting on single-phase current supply because of a partial displacement of magnetic lines or flux at the field poles through auxiliary currents and flux produced in closed conductive rings around parts of the pole tips.

SHADOW TUNING INDICATOR. A tuning meter which has a small piece of cardboard attached to its pointer, with a pilot lamp mounted behind the pointer so that a shadow is thrown upon a glass screen. The meter is so constructed and connected into a radio receiver circuit that the shadow will be narrowest when the receiver is accurately tuned to a station.

SHIELD. A metal can or housing placed around a radio part to prevent its electric and magnetic fields from affecting nearby parts or to prevent other fields from affecting it.

SHIELDED WIRE. Insulated wire having around it a shield of tinned braided copper wire.

SHORT CIRCUIT. A low-resistance connection, usually accidental, occurring between the two sides of a circuit or between any two circuit terminals; it often results in excessive current flow and damage to some parts.

SHORT WAVES. Wavelengths shorter than those included in the broadcast band, hence waves shorter than 200 meters. Short waves correspond to frequencies higher than the highest broadcast band frequency of 1600 kilocycles.

SHORT-WAVE CONVERTER. A radio device which can be connected between a broadcast receiver and its antenna system to permit reception of higher-frequency stations which the receiver could not otherwise receive. It consists essentially of an oscillator-mixer-first detector arrangement like that used in a superheterodyne receiver, and serves to convert the high-frequency signals to a broadcast band frequency which can be handled by the regular receiver.

SHUNT. A resistor placed across the terminals of an ammeter to allow a definite part of the circuit current to go around the meter. Any parallel-connected part, or the act of placing one part in parallel with another.

SHUNT WINDING. In a motor, generator or other electric machine, a winding through which flows only a portion of the total current entering or leaving the machine; a winding which is in parallel with the armature windings.

SIGNAL. A radio wave or alternating current which carries intelligence of any form. More generally, any alternating current having other than an a.c. power line frequency.

SIGNAL GENERATOR. A test instrument used by radio servicemen to produce a modulated or unmodulated r.f. carrier signal having a known radio frequency value, sometimes also at a known voltage. It is used as a signal source during alignment of a radio receiver and when hunting for the defective part in an improperly operating receiver. An all-wave signal generator has several ranges, and hence can be set to any carrier frequency which an all-wave receiver can receive.

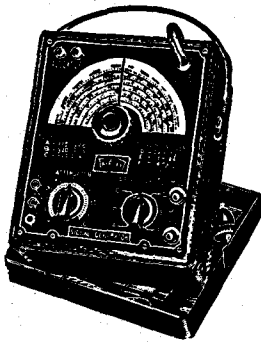

SIGNAL-TO-NOISE RATIO. The ratio of the intensity of a desired signal at any point to the intensity of noise there is to interfere with reception.

SIGNAL TRACING. A radio receiver servicing technique which involves tracing the progress of a radio signal through an entire receiver, stage by stage, while the receiver is in operation. Measurements which are made during this procedure by a special signal-tracing test instrument indicate when the defective part or stage has been reached.

SINE WAVE. The rise, fall and reversal of an alternating current or voltage which would be induced in a conductor rotating at constant speed in a uniform magnetic field and moving around a circle in that field. The ideal form of an alternating wave.

SINGLE-BUTTON CARBON MICROPHONE. A microphone having a carbon-filled button on only one side of its diaphragm.

SINGLE-POLE SWITCH. A toggle or knife switch having only one movable contact arm or blade.

SINGLE-THROW SWITCH. A toggle or knife switch in which each movable contact arm or blade always touches the same contact when closed.

SKIP DISTANCE. The distance between the farthest point reached by the ground wave of a radio station and the nearest point at which the reflected skip wave comes back to earth. This skip effect usually occurs only during high-frequency transmissions (short-wave transmissions).

SKY WAVES. Radio waves which travel up into the sky from the transmitting antenna and are reflected back to earth by the Kennelly-Heaviside ionized layer.

SLIDE RULE DIAL. A type of tuning dial used on radio receivers, in which a vertical marker moves horizontally over long straight scales resembling the scales of a slide rule.

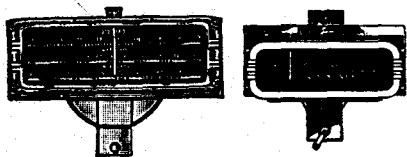

SLIDE RULE DIALS

SNAP SWITCH. A switch in which movement of the control member first places tension on a spring, after which the spring tension is released to suddenly open (and usually to suddenly close) the switch contacts.

SOCKET. A mounting device for tubes, plug-in coils, plug-in condensers, plug-in resistors and crystals, having holes with spring clips arranged to fit and grip the terminal prongs of the part being plugged in. Also, a bayonet or screw type socket for pilot lamps.

SOLDER. An alloy of lead and tin which melts at a fairly low temperature and is used in radio for making permanent electrical connections between parts and wires.

SOLDERING IRON. A device used to apply heat to a joint which is to be made permanent by soldering.

SOUND. A vibration of a body at a rate which can be heard by human ears. The extreme limits of human hearing are about 20 cycles and 20,000 cycles. Sound can travel through any medium which possesses the ability to vibrate; the resulting traveling vibrations are called sound waves.

SOURCE. A term sometimes used to describe the part which is supplying electrical energy or radio signals to a circuit.

SPACE CHARGE. A gathering of electrons near the cathode of a vacuum tube. Being negative, it tends to limit the number of electrons which can reach the plate, and hence limits the plate current.

SPAGHETTI. Heavily varnished cloth tubing sometimes used to provide additional insulation for radio circuit wiring.

S.P.D.T. SWITCH. Single pole, double throw switch.

SPECIFIC GRAVITY. The ratio of the weight or mass of a substance to the weight or mass of an equal volume of pure water at the same temperature, or sometimes at a reference temperature of four degrees centigrade.

SPEED CONTROLS. In a television receiver, the adjustable controls that set the operating frequencies of the vertical and horizontal oscillators at values which permit them to fall into step with or synchronize with the incoming signals.

SPIDER. A highly flexible fiber ring which serves to center the voice coil of a dynamic loudspeaker without appreciably hindering the in-and-out motion of the voice coil and its attached diaphragm.

SPLICE. A joint between two wires which possesses mechanical strength as well as good electrical conductivity.

SPLIT PHASE MOTOR. An alternating-current induction motor which is made self-starting on single-phase current by using two stator windings, in one of which the current is displaced in phase with reference to that in the other winding to produce a rotating field somewhat like the rotating field secured from two-phase current.

S.P.S.T. SWITCH. Single pole, single throw switch.

SQUEALING. A condition in which a high-pitched note is heard along with the desired radio program. It can be due to interference between stations or to a number of other causes.

SQUIRREL CAGE MOTOR. An alternating-current induction motor in which the conductors on the rotor consist of bars parallel to the rotor axis or shaft, joined together at the front and rear of the armature by conductive rings. The conductors, neglecting their supports, would have the general form of a squirrel cage.

S.S.C. Single silk covered wire.

STAND-OFF INSULATOR. An insulator used to support a wire at a desired distance away from the building or other support on which the insulator is mounted.

STATIC. Interfering noises heard in a radio receiver due to radio waves created by atmospheric electrical disturbances such as discharges of lightning.

STATOR. The fixed set of plates in a variable condenser.

STATOR. The parts of an alternating-current motor or generator on which are the stationary windings.

STEP-DOWN TRANSFORMER. A transformer in which the secondary winding has fewer turns than the primary, so that the secondary delivers a lower voltage than is supplied to the primary.

STEP-UP TRANSFORMER. A transformer in which the secondary winding has more turns than the primary so that the secondary delivers a higher voltage than is applied to the primary.

STORAGE BATTERY. One or more secondary or storage cells connected together, usually in series.

STORAGE CELL. A secondary cell. More specifically, one of the cells of the ordinary automotive storage battery, delivering a voltage slightly higher than two volts and capable of being recharged.

STRANDED WIRE. A wire which consists of a number of finer wires twisted together.

SULPHATION. In a lead-acid storage battery, the conversion during discharge of an excessive amount of the active sponge lead and peroxide of lead into inactive sulphate of lead.

SUPERHETERODYNE RECEIVER. A type of radio receiver in which the incoming modulated r.f. signals are amplified a small amount in the preselector, then fed into the frequency converter section (consisting of the oscillator, mixer and first detector) for conversion into a fixed, lower carrier frequency called the i.f. value of the receiver. The modulated i.f. signals are given very high amplification in the i.f. amplifier stages, then fed into the second detector for demodulation. The resulting audio signals are amplified in the conventional manner by the audio amplifier, then reproduced as sound waves by the loudspeaker.

SUPPRESSOR. A resistor inserted in series with the spark plug lead or the distributor lead of an automobile engine to suppress spark interference which might otherwise interfere with reception of radio programs in the auto radio set.



SURFACE METAL RACEWAY. A thin-walled flattened metallic covering and support for insulated wires, de-

signed for mounting on the exposed surfaces of building members, and usually having a removable cover.

SWEEP CIRCUIT. A special oscillator circuit which generates a voltage having a sawtooth wave form suitable for making the electron beam of a cathode ray tube sweep back and forth across the fluorescent screen.

SWITCH. A mechanical device for opening and closing an electrical circuit, or for changing the connections between parts or circuits.

SWITCHBOARD. A large exposed panel or panels carrying on the front, the back, or both front and back, switches, buses, protective devices and instruments for measuring and indicating or recording values of current and voltage in parts of circuits controlled by equipment on the switchboard.

SYMBOL. A simple design used to represent a radio part on a schematic circuit diagram. A letter used in formulas to represent a particular quantity.

SYNC SEPARATOR. In a television receiver, the filter system that separates the synchronizing signal from the other received signals.

SYNC SIGNAL. A synchronizing signal in television.

SYNCHRONIZING SIGNAL. The portion of a television signal that keeps the motions of the electron beam in the picture tube of the receiver in step with or synchronized with motions of the beam in the camera tube at the transmitter.

SYNCHRONOUS. Happening at the same time; having the same alternating phase relations and period; maintaining a frequency exactly proportional to operating speed, or a speed exactly proportional to supply frequency.

SYNCHRONOUS VIBRATOR. A vibrator which serves the dual function of converting a low d.c. voltage to a low a.c. voltage and at the same time rectifying a high a.c. voltage. When used in an auto radio power pack, it eliminates the need for a rectifier tube.

T

TABLE MODEL RECEIVER. A radio receiver having a cabinet of suitable shape and size to permit placing on a table.

TAP. A connection made to a point intermediate between the ends of a coil, a resistor, or other element in a circuit or line.

TELEVISION. Reproduction of a scene, which may include moving objects and persons, at a distance from the point where the scene exists. Television requires the conversion of lights and shades of a scene into variations of voltage and current, transmission of these variations as radio waves, and reconversion at the receiver of the voltage variations into lights and shades, all at practically the same instants that changes are occurring in the distant scene.

TELEVISION CONNECTION. Terminals which permit the use of an ordinary radio receiver in amplifying and reproducing the audio signals as-

sociated with a television program. These terminals simply connect to the input of the audio amplifier in the receiver, just as do the phonograph connection terminals.

TERMINAL. A point to which electrical connections are made.

TEST LEAD. A flexible insulated lead used chiefly for connecting meters and test instruments to a circuit under test.



TEST PROD. A sharp metal point provided with an insulated handle and means for connecting the point to a test lead. It is used for making a touch connection to a circuit terminal.

TETRODE. A four-electrode vacuum tube. Ordinarily, these electrodes will be the cathode, control grid, screen grid, and anode.

THERMAL DEVICES. Devices such as relays and cutouts that are operated usually by the expansion of parts which are heated by flow through them or through adjacent parts of an electric current. Excessive current causes excessive heating, and the expansion that operates the device. In other styles the overheating melts a fusible metal which releases the operating parts.

THERMOCOUPLE. A device that converts heat directly into emf and electric current. The thermocouple consists of two metals, such as copper and constantan, directly in contact at a point which is heated and either directly in contact or connected through a meter or similar unit at a point kept relatively cool. The emf is proportional to the difference between temperatures at the hot and cold junctions.

THERMOCOUPLE METER. A moving coil meter equipped with a thermocouple heated by alternating current to be measured and producing a direct current that actuates the meter.

THERMOSTAT. A device in which changes of temperature cause expansion and contraction of an element whose resulting motion operates switches or other control devices in electric circuits.

THREE-BAND RECEIVER. A radio receiver having three different tuning ranges. One range will always include the broadcast band, and may also include police stations operating on frequencies just above the broadcast band. The other two ranges will usually be from about 2.2 mc. to about 7.5 mc., and from about 7.25 mc. to about 24 mc.

THREE-WAY SWITCH. A switch that connects one of its terminals alternately to two other terminals, used in a circuit for controlling a single lamp from two different locations.

THREE-WIRE SYSTEM. A direct-current supply system in which the voltage from one wire, called the neutral, to either of the others is half that which exists between the other two wires. For example, the voltage from the neutral to either of the "outside wires" may be 110, and between the two outside wires may be 220.

TICKLER. A coil connected to series with the plate circuit for the purpose of feeding a portion of the amplified signal current back into the grid cir-

cuit by induction for repeated amplification. The tickler is used chiefly in regenerative detector circuits.

TIME DELAY DEVICE. A device such as a relay or circuit breaker that operates only after a period of time following some change of current or voltage, or some other action in an electrical system.

TIME SIGNALS. Naval Observatory time signals which are broadcast regularly each day by government radio station NAA in Arlington, Virginia on a number of different frequencies. They can generally be picked up during the final minute of each hour on 9,425 kc. by a good all-wave receiver. These signals are used by army and navy stations, ships at sea, jewelers, and other persons throughout the entire country for setting timepieces. NAA signals are re-broadcast by some broadcasting networks at certain hours.

TOGGLE SWITCH. A small switch operated by means of a lever.

TOLERANCE. The permissible variation from a rated or assigned value.

-tone. The general character of a reproduced radio program as it affects the human ear.

tone control. A circuit control sometimes provided on a radio receiver to permit strengthening the response at either low or at high audio frequencies at will, so as to make the reproduced radio program more pleasing to a particular audience.

TOP CAP. A metal cap sometimes placed on the top of a vacuum tube and connected to one of the electrodes, usually the control grid.

TORQUE. Turning effort. The effect of a force that tends to cause rotation of parts about a center. An electric motor exerts torque at its shaft when supplied with current, and if the torque is sufficiently great it will cause the shaft to rotate.

TRACKING. A term used to indicate that all of the tuned circuits in a receiver follow the frequency indicated by the tuning dial pointer as the receiver is tuned over its entire tuning range.

TRANSCRIPTION. An electrical transcription, in which a complete radio program is recorded for future use.

TRANSFORMER. A device usually consisting of two insulated windings on a common iron or steel core, in which alternating current supplied to one winding (the primary) induces by electromagnetic induction alternating emf's in the other winding (the secondary) and will produce alternating currents in a conductive circuit connected to the secondary winding. The voltage from the secondary may be higher or lower than that furnished to the primary winding. See Step-Down and Step-Up Transformers.

TRANSMISSION LINE. Any set of conductors used to carry r.f. or a.f. signals or energy from one location to another.

TRANSMITTER. A comprehensive term applying to all of the equipment used for generating and amplifying an r.f. carrier signal, modulating this carrier with intelligence, and radiating the modulated r.f. carrier into space after

it is amplified additionally and fed to the transmitting antenna.

TREBLE. A term sometimes used to designate high audio frequencies.

T.R.F. Tuned radio frequency.

TRIMMER CONDENSER.

A small semi-adjustable condenser, usually adjusted with a screwdriver, and used in the tuning circuits of radio receivers and other radio apparatus to permit accurate alignment of these circuits.



TRIODE. A three-electrode vacuum tube, usually having a cathode, control grid and anode.

TRUE POWER. The power actually consumed in an alternating-current circuit or equipment, is distinguished from the apparent power which would be equal to the number of volts multiplied by the number of amperes input to the circuit. See Power Factor. Power factor is the ratio of true power to apparent power.

TUBE. A vacuum tube, gaseous tube or photoelectric cell mounted in a somewhat tube-shaped glass or metal envelope.

TUBE TESTER. A test instrument used to test the condition of radio tubes.

TUBULAR CONDENSER.

A paper or electrolytic condenser having as its plates long strips of foil which have been rolled into a compact tubular shape.



TUNED CIRCUIT. A resonant circuit, consisting of a coil and condenser which are preset or can be adjusted to give resonance at a desired frequency.

TUNED RADIO FREQUENCY RECEIVER. A receiver in which r.f. amplification is provided by a number of vacuum tube amplifier stages, each of which has one or more circuits which are tuned to resonance at the incoming signal frequency by a section of the gang tuning condenser. The amplified r.f. signals are fed directly into the detector for demodulation.

TUNGAR BULB. A gaseous diode rectifier tube employed in battery chargers.

TUNGSTEN. A pure metal used in radio chiefly for the filaments and other elements of radio tubes.

TUNING. The process of varying the inductance or capacity in a coil-condenser circuit to provide resonance at a desired frequency. Also, the process of setting all of the tuning circuits in a radio receiver simultaneously to a desired frequency by rotating the tuning dial or pressing a button of a push-button tuner.

TUNING EYE. A cathode ray tuning indicator tube.

TUNING INDICATOR. A device which indicates when a radio receiver is tuned accurately to a radio station.

TUNING METER. An ordinary meter connected into a radio receiver circuit for use as a tuning indicator.

TURN. In a coil, one complete loop of wire around the coil form.

TURNTABLE. In a record player or electric phonograph, the motor-driven disc on which the phonograph record is placed. In a sound recorder, the motor-driven disc on which is placed the disc to be cut.

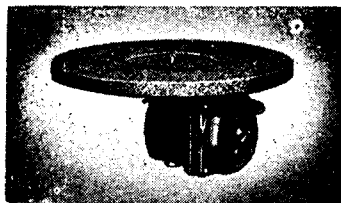

TWO-BAND RECEIVER. A radio receiver having two reception ranges. One will generally cover from 535 kc. to 1720 kc., which includes the broadcast band and some police calls, and the other will generally be between 5.65 mc. and 18.1 mc.

TWO-PHASE. Descriptive of an alternating current circuit or equipment in which there are at the same time two voltages and two currents differing in phase position by 90 electrical degrees.

U

ULTRA-HIGH FREQUENCY. A term usually used to indicate a frequency higher than about 30 megacycles. Abbreviated u.h.f.

UNIVERSAL OUTPUT TRANSFORMER. An iron-core a.f. output transformer having a number of taps on its windings to permit its use in practically any average radio receiver.

UNIVERSAL RECEIVER. A receiver capable of operating from either a.c. or d.c. power.

UNMODULATED. Without modulation. The r.f. carrier signal alone, as it exists during pauses between station programs.

V

V. Voltage. Volts.

VACUUM. A space from which practically all air has been removed.

VACUUM TUBE. A device consisting of a number of electrodes mounted in an envelope or housing from which practically all air has been removed. Also called an electron tube or radio receiver.

VACUUM TUBE VOLTMETER. A test instrument which utilizes the rectification characteristic of a vacuum tube for measuring voltages without affecting the circuit to which the instrument is connected.

VALVE. The term used in Great Britain to designate radio tube.

VARIABLE CONDENSER. A condenser whose capacity may be changed either by varying the space between plates (as in a trimmer condenser) or by varying the amount of meshing between the two sets of plates (as in a tuning condenser).

VARIABLE RESISTANCE. A resistance which can be changed in value while in use.

VERNIER CONDENSER. A small variable tuning condenser which is

placed in parallel with a larger tuning condenser for the purpose of providing a finer adjustment after the large condenser has been set roughly to the desired position.

VERNIER DIAL. A type of tuning dial in which a complete rotation of the control knob makes the tuning condenser shaft rotate only a small fraction of a revolution, thereby permitting fine and accurate tuning.

VERTICAL ANTENNA. A single vertical metal rod, suspended wire or metal tower used as an antenna.

VERTICAL OSCILLATOR. In a television receiver, the oscillator that utilizes the vertical synchronizing and blanking signals, also the equalizing signals, to produce voltages which, when amplified, operate the deflecting plates or coils in the picture tube.

VIBRATOR. An electromagnetic device which converts a d.c. voltage to pulsating d.c. or a.c. It is used in the power packs of auto radios and some public address amplifiers to convert the 6-volt auto storage battery voltage to a low a.c. voltage.



The a.c. voltage is then stepped up by a power transformer, and converted into a high d.c. voltage either by a conventional rectifier tube circuit or by an extra set of contacts on the vibrator itself.

VIDEO. A latin word meaning "I see," applied to television parts and circuits which handle picture signals, and applied also to signals associated with the picture being transmitted.

VIDEO AMPLIFIER. The amplifier for video signals in a television receiver or transmitter.

VIDEO FREQUENCY. One of the frequencies present in the output of a television camera as a result of scanning the image being transmitted. It may be any value from almost zero to well over 4,000,000 cycles.

VIDEO SIGNAL. The changing voltage which corresponds to the changing lights and shades in the image being scanned at the television receiver and reproduced at the receiver.

VOICE COIL. The moving coil which is attached to the diaphragm of a dynamic loudspeaker.

VOLT. The practical unit of voltage. One volt will send a current of one ampere through a resistance of one ohm.

VOLT-OHM-MILLIAMMETER. A test instrument having provisions for measuring voltage, resistance and current. It consists essentially of a single meter having the necessary number of scales, and a switch which places the meter in the correct circuit for a particular measurement.

VOLTAGE AMPLIFICATION. Amplification which increases the voltage of a signal rather than its power. Also, a rating obtained by dividing the a.c. output voltage of an amplifier stage by the a.c. input voltage.

W

VOLTAGE DIVIDER. A resistor, at an intermediate point or points on which are taps that permit taking certain fractions of the overall voltage from between the taps or between the taps and the ends of the resistor. Instead of fixed taps there may be one or more movable contacts that slide on the resistor or are connected to it through switches.

VOLTAGE DROP. A difference in voltage due to flow of current between two points separated by resistance in conductors; equal to the current in amperes multiplied by the resistance in ohms through which the current flows.

VOLTAGE REGULATOR. A device used in a generator circuit or in connection with a generator to maintain a practically constant voltage as there are changes in speed or load.

VOLTAGE REGULATOR TUBE. A two-element gaseous tube used in a.c. radio receivers to keep the input a.c. voltage to the receiver power pack essentially constant despite wide variations in the line voltage. Also used to maintain a constant d.c. potential across a circuit.

VOLTAGE RATING OF A CONDENSER. The maximum sustained voltage which can safely be applied across the terminals of a condenser without causing breakdown of the insulation between condenser plates.

VOLTAGE TO GROUND. In an ungrounded or two-wire circuit, the greatest voltage between the specified conductor and any other conductor. In a grounded circuit, the voltage between a specified conductor and the point in the circuit that is grounded.

VOLTMMETER. A voltmeter and an ammeter in a single case, or sometimes an instrument for measuring watts (volts \times amperes) in a direct-current circuit.

VOLTMETER. An instrument for measuring differences of potential or voltage and indicating the differences directly in a number of volts on its scale.

VOLUME. The intensity of the sound produced by a radio loudspeaker.

VOLUME CONTROL. A device which varies the a.f. output of a receiver or p.a. amplifier, thereby changing the volume of the sound produced by the loudspeaker.

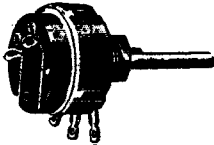

VOLUME EXPANDER. A special manually-adjusted audio circuit which can be set to increase the volume range of a radio program or phonograph record by making the weak passages weaker and the loud portions of the program louder. Volume expanders are also made as self-contained, self-powered units which can be inserted between a phono pick-up and the input terminals of an audio amplifier.

VOLUME UNIT. A recently developed method of expressing the power level in broadcast equipment with reference to a fixed power level of .001 watt.

VU. Volume unit.

WAFER SOCKET. A type of socket in which the clips for gripping the tube prongs are mounted between two wafers or sheets of insulating material.

WATERPROOF. So protected or constructed that moisture will not interfere with satisfactory operation.

WATERTIGHT. So protected or constructed that water will not enter the enclosure.

WATT. The practical unit of electric power. In a direct-current circuit the expended power in watts is equal to the number of volts applied to the circuit multiplied by the number of amperes flowing in the circuit due to the applied voltage. In an alternating-current circuit the watts of power consumed are equal to the number of applied volts multiplied by the number of amperes of current, and multiplied by the power factor. Except in an alternating-current circuit containing no appreciable inductance or capacitance, or containing only resistance, the watts of power will be less than the volt-amperes.

WATTAGE RATING. A rating expressing the maximum power which a device can safely absorb or handle. To determine how high a wattage rating is required for a particular resistor, multiply the value in ohms of the resistor by the square of the current which is to flow through the resistor (resistance \times current \times current), and choose a resistor having a wattage rating approximately twice the computed value so as to give ample margin of safety in operation.

WATTMETER. A meter for measuring and indicating directly in watts on its scale the power being consumed in a circuit or in equipment to which the wattmeter is connected.

WAVE. Any continually varying quantity, such as an alternating current, sound wave, or radio wave.

WAVELENGTH. The distance travelled in a time of one cycle by an alternating current, sound wave or radio wave. This is the same as the distance between successive peaks having the same polarity in the wave. For wave motion in ether the wavelength in meters is equal to the number 299,820,000 divided by the frequency in cycles per second.

WAVE TRAP. A device sometimes connected to the aerial system of a radio receiver to reduce the strength of signals at a particular frequency, such as at the frequency of a strong local station which is interfering with reception of other stations.

WEATHERPROOF. So protected or constructed that exposure to weather will not prevent or interfere with satisfactory operation.

WHEATSTONE BRIDGE. An instrument that allows calculation of values of resistance, inductance or capacitance in parts or circuits connected into the bridge circuit; the calculation involving one ratio of resistances which are adjustable in the bridge circuit, and another ratio in which one value is known and the other is the value of the unknown resistance, inductance or

capacitance. When adjustments make the two ratios equal the bridge is said to be balanced, and the condition of balance may be indicated by a galvanometer or other current-sensitive device.

WHITE LEVELS. The range of voltages through which vary the picture signal portions of a television signal. The maximum white level is at the extreme limit of carrier modulation.

WIND CHARGER. A generator driven by a propeller mounted on or geared to its shaft. The unit must be mounted in a location where wind velocity is sufficient to rotate the propeller; this means it should be on a mast or tower extending well above surrounding trees and buildings. The generator is usually of the d.c. type, and is used for charging a radio storage battery or the batteries of a 32-volt farm lighting plant.

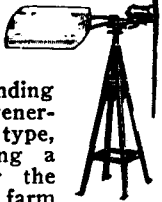

WINDING. One or more turns of wire which make up a continuous coil. Used chiefly in coils, transformers and electromagnetic devices.

WIRE. A metallic conductor having essentially uniform thickness, used in radio chiefly to provide a path for electric currents between two points. It may be bare or covered with an insulating material such as enamel, cotton, linen or silk.

WIRED RADIO. Communication by means of radio waves or silk.

WIRELESS. Radio.

WIRELESS RECORD PLAYER. A motor-driven turntable and phono pick-up mounted in the same cabinet with and r.f. oscillator. The phono pick-up converts a recording into a.f. signals which modulate the r.f. carrier of the oscillator. The resulting signal is radiated through space, as a miniature broadcast signal, and can be picked up by any radio receiver in the same house merely by tuning that receiver to the broadcast band frequency on which the wireless record player is operating.

WIRE-WOUND RESISTOR. A resistor which is constructed by winding a high-resistance wire on an insulating form. The resulting element may or may not be covered with a ceramic insulating layer.

WORK. A force multiplied by the distance through which it causes a mass or weight to move. If a force of one pound causes a movement of one foot, the work done is equal to one foot-pound, this being one of the units in which work may be measured. Work is the result of a force acting against some form of opposition to motion. It is measured as the product of the force and the distance through which it acts.

X

X. A letter used in formulas to designate reactance.

XC. A symbol used for capacitive reactance in ohms.

X-CUT. A piezo-electric crystal or quartz plate cut in such a manner that

X-axis is perpendicular to its faces. Also sometimes called Currie cut and a zero-angle cut.

X-RAYS. A form of radiation which will penetrate opaque substances and affect photographic plates or films, or produce fluorescence, thus showing otherwise invisible differences in structure as lights and shadows. The rays are produced by the striking of an electron stream against a solid object called the target in an X-ray tube.

X'S. Disturbances caused by static.

Y

Y. Symbol used for the admittance in ohms.

Y-AXIS. In a quartz crystal, a line perpendicular to the two diametrically opposite parallel faces. It lies in a plane which is at right angles to the x-axis.

Y-CUT. A piezo-electric crystal cut in such a manner that the y-axis is perpendicular to its faces. Also sometimes

called a face-parallel cut or thirty-degree cut.

Z

Z. A letter used in formulas to designate impedance.

ZERO-BEAT. A condition where two frequencies are exactly the same.

ZERO BIAS. Zero voltage between the control grid and cathode of a vacuum tube, so that these two electrodes are at the same potential.

RMA COLOR CODE FOR RESISTORS

BACKGROUND COLOR		METHOD I		METHOD II	
A	B	C	D	B	A
COLOR BANDS A, B, AND C GIVE VALUE. GOLD OR SILVER BAND D, USUALLY OMITTED, INDICATES TOLERANCE. BLACK BACKGROUND—UNINSULATED. TAN BACKGROUND—INSULATED.		BODY COLOR (A), END COLOR (B), AND DOT OR BAND COLOR (C) GIVE VALUE. GOLD OR SILVER BAND D, USUALLY OMITTED, INDICATES TOLERANCE.			
Color	Figure	COLOR A GIVES FIRST FIGURE OF RESISTOR VALUE.			
BLACK	0	COLOR B GIVES SECOND FIGURE OF RESISTOR VALUE.			
BROWN	1	COLOR C GIVES NUMBER OF CIPHERS FOLLOWING THE FIRST TWO FIGURES.			
RED	2	COLOR D: GOLD BAND INDICATES ± 5% TOLERANCE. SILVER BAND INDICATES ± 10% TOLERANCE. NO BAND INDICATES STANDARD ± 20% TOLERANCE.			
ORANGE	3				
YELLOW	4				
GREEN	5				
BLUE	6				
VIOLET	7				
GRAY	8				
WHITE	9				

EXAMPLES—METHOD I

BAND A	BAND B	BAND C	BAND D	BACKGROUND	RESISTOR VALUE
Green (5)	Black (0)	Black ()	None	Black	50 ohms ± 20%, uninsulated.
Red (2)	Green (5)	Brown (0)	Silver	Brown	250 ohms ± 10%, insulated.
Green (5)	Black (0)	Yellow (0000)	None	Black	500,000 ohms ± 20%, uninsulated.
Orange (3)	Green (5)	Green (00000)	Gold	Brown	3,500,000 ohms ± 5%, insulated.

EXAMPLES—METHOD II

BODY (A)	END (B)	DOT OR BAND (C)	RESISTOR
Green	Black	Black	50 ohms
Red	Green	Brown	250 ohms
Green	Black	Yellow	500,000 ohms
Orange	Green	Green	3,500,000 ohms

The standard color code for resistors was developed by the Radio Manufacturers' Association of marking ohmic values on fixed carbon and metallized resistors. Two marking methods are in common use.

Method I markings are used chiefly on resistors having leads coming straight

out from the ends; with this method, all color bands are equal in width, and may or may not be touching each other.

Method II markings are identified by the fact that the color bands or colored areas are of different widths. This method is invariably used on resistors having leads coming out from the sides,

and sometimes also on end-lead resistors.

The tolerance marking, when present, indicates the amount by which the resistor may deviate from its rated value. Thus, a 100-ohm resistor with ± 5% (plus or minus five percent) tolerance may have an actual value up to 5 ohms higher or lower than 100 ohms (between 95 and 105 ohms).

Uninsulated resistors marked according to Method I have a black background color, while insulated resistors have a tan background color.

Missing color bands in Method I markings are assumed to be the background color (brown or black). A missing end color (B) or dot color (C) in Method II markings is assumed to be the same as the body color (A).

With Method I, band A is never black, for a resistor value cannot start with zero. When you encounter a resistor with a black band at the left end, it is either an uninsulated Method I resistor which you are trying to read backward, or it is a Method II resistor with the black band serving as end color B.

CONDENSER COLOR CODE. The basic scheme of the RMA Color Code is also used for designating values of fixed mica condensers. Three colored dots will usually be placed on the bakelite body of the condenser, along with an arrow or other markings which indicate the direction in which the dots are to be read. The value of the condenser in micro-microfarads is read in exactly the same way as for resistors; the first color dot gives the first figure in the condenser value; the second color dot gives the second figure; the third color dot gives the number of ciphers to be added to the first two figures.

TWO RESISTORS IN SERIES: TOTAL	$R = R_1 + R_2$	OHMS LAW FOR D.C., WHERE
	$R_1 \times R_2$	R IS RESISTANCE IN OHMS,
TWO RESISTORS IN PARALLEL: TOTAL	$R = \frac{R_1 \times R_2}{R_1 + R_2}$	E IS VOLTAGE IN VOLTS, I
	$C_1 \times C_2$	IS CURRENT IN AMPERES,
TWO CONDENSERS IN SERIES: TOTAL	$C = \frac{C_1 \times C_2}{C_1 + C_2}$	AND P IS POWER IN WATTS:
	$C_1 + C_2$	$E = I \times R$
TWO CONDENSERS IN PARALLEL: TOTAL	$C = C_1 + C_2$	$R = E \div I$
		$P = E \times I$
		$I = E \div R$
		$P = I^2 \times R$
		$P = E^2 \div R$

HOW TO READ SCHEMATIC DIAGRAMS

A SCHEMATIC circuit diagram is a symbolic means of showing electrical connections in radio apparatus. It tells very little about how the various parts look, how they are constructed, or where they are located on the chassis, but it does tell how the parts must be connected together electrically to make the set operate. The schematic diagram also provides a quick means for checking

connections during construction work and when hunting for defects in improperly operating apparatus.

A circuit diagram is read from left to right when tracing intelligence signals from the antenna to the loudspeaker. Look for the antenna or input terminals at the upper left, then move across the diagram one stage at a time. Usually the stages will be labelled to indicate their

functions, so the tube lineup of a receiver can be determined almost at a glance once a bit of experience is secured with these diagrams.

The power pack is always placed near the bottom of the diagram. It can readily be identified by the fact that it will have an input connection to a power line or storage battery. In battery-operated equipment, the circuit will usually show

HOW TO READ SCHEMATIC DIAGRAMS

only the terminals to which the A, B, and C batteries are to be connected.

The preliminary scanning of a complete diagram to "get your bearings" is about the only time when a schematic circuit diagram need be read completely all at once. The radio man is usually interested only in one particular section of the diagram, for he works on only one section of a receiver at a time.

One important fact to realize is that junctions of wires on a schematic may be arranged differently from corresponding terminals on actual apparatus. Thus, there may be two resistors and two condensers connected to a particular tube socket terminal on the chassis, but only a single line going to that same terminal on the schematic diagram; somewhere along the line, however, you will come to the symbols for these same resistors and condensers. A schematic diagram is drawn so it will be easy to trace through, while parts are arranged on a chassis so

connections will be easy to make, leads will be as short as possible, and parts which might interfere with each other are kept far apart.

The symbols used on schematic circuit diagrams to represent various radio parts are shown in the accompanying chart. When several different symbols for a particular part are in common use, these are shown. Variation in symbols are most evident in the case of radio tubes, but will give no difficulty once you learn that a dotted or zig-zag line always represents a grid, and a solid line, solid box or hollow box represents an anode.

In battery symbols, the short line is always negative or minus and the long line is positive or plus.

Several methods of showing cross-overs of wires are in common use, but there should be no confusion if you first look over a new diagram to see which method is employed. If a half-circle is used to bring one wire over another

when there is no connection, you can be sure that a connection is intended when wires cross without having this half-circle symbol. If there are no half circles anywhere on the diagram at cross-over points, and there are solid dots at some cross-overs but not all, then the solid dot indicates a connection and the plain cross-over indicates no connection. In any event, a solid dot at a junction will always indicate a connection.

Filament circuit connections are so standardized that a radio man seldom bothers to draw them in. Instead, he brings the two filament leads out of the tube symbol a short distance, labels one X, and labels the other Y. Corresponding letters will be found on the two leads of the filament winding in the power pack. This system of marking indicates that all points marked X are to be connected together and to the X terminal of the filament winding, and all points marked Y are to be connected to the Y terminal of the filament winding. The tube filaments are then connected in parallel, as is always done in a.c. receivers, and almost always in battery-operated sets.











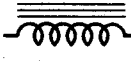





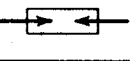

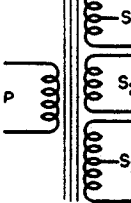
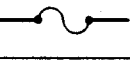
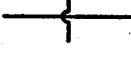
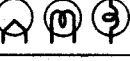
Sometimes a ground symbol will be used in place of Y, indicating that those terminals are simply connected to the nearest convenient chassis lug. Then again, the letter H will be used on all filament leads, indicating that all tube filaments and the filament transformer are to be connected in parallel, with polarity being unimportant.

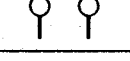
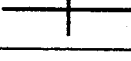
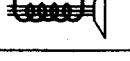
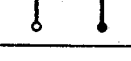
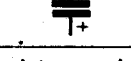
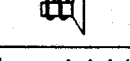
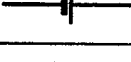
In universal a.c.-d.c. receivers, the filaments are invariably connected in series. Sometimes the connections are shown right on the schematic diagram, but usually the filament symbols will be omitted from the tube circles, and will be shown instead near the bottom of the diagram, all connected together as they should be. When you encounter this type of connection, be sure to follow the exact order of connections shown on the diagram. The filament of the power output tube and rectifier tube must often have particular positions in the line-up to give satisfactory operation.

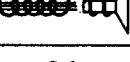
Other methods of showing series filament connections are generally self-explanatory once they are studied for a few minutes while keeping the above basic facts in mind.

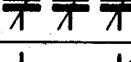
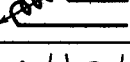
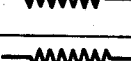
Connections to the chassis are usually indicated by a ground symbol. The chassis of a universal a.c.-d.c. receiver is seldom connected directly to an external ground.

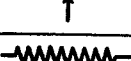
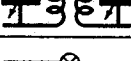
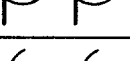
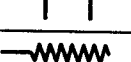
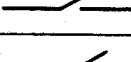
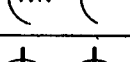
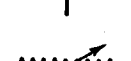
Bottom views of tube sockets, showing terminal connections, are usually given either directly on a schematic circuit diagram or on a separate diagram. However, schematically drawn tube terminal connections are not always drawn in the same rotation as the actual socket connections. If a separate diagram indicating the proper terminal number is not included, a tube chart or manual must be referred to. Always use the aligning key as your guide for locating a particular terminal when working with octal-base tubes. With older tube bases, the spacings between prongs are unequal to permit locating a particular prong. In some cases the spacing is equal but the filaments are indicated by larger socket holes. With this as a guide the other elements may be identified.

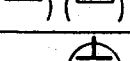
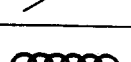
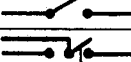
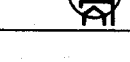
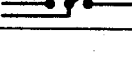
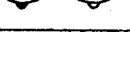
 ANTENNA (AERIAL)	 IRON-CORE CHOKE COIL	 SWITCH (ROTARY OR SELECTOR)
 GROUND (OR CHASSIS CONNECTION)	 R F TRANSFORMER (AIR CORE)	 CRYSTAL DETECTOR
 LOOP AERIAL (USUALLY BUILT INTO CABINET OF RECEIVER)	 A.F TRANSFORMER (IRON CORE)	 LIGHTNING ARRESTER
 CONNECTION	 POWER TRANSFORMER P: 115-VOLT PRIMARY S ₁ : CENTER-TAPPED SECONDARY FOR FILAMENTS OF SIGNAL CIRCUIT TUBES S ₂ : SECONDARY WINDING FOR RECTIFIER TUBE FILAMENT S ₃ : CENTER-TAPPED HIGH-VOLTAGE SECONDARY WINDING	 FUSE
 NO CONNECTION		 PILOT LAMP
 NO CONNECTION (WHEN CONNECTIONS ARE INDICATED BY DOTS)		 HEADPHONES
 CONNECTION (WHEN NO-CONNECTION CROSS-OVERS ARE INDICATED BY HALF-CIRCLES)		 FIXED CONDENSER (MICA OR PAPER)
 TERMINAL	 FIXED CONDENSER (ELECTROLYTIC)	 LOUDSPEAKER, P.M. DYNAMIC
 ONE CELL OR "A" BATTERY	 VARIABLE CONDENSER <small>ROTOR PLATES</small>	 LOUDSPEAKER, ELECTRODYNAMIC
 MULTI-CELL OR "B" BATTERY	 GANG TUNING CONDENSER	 PHONO PICK-UP.
 RESISTOR	 TRIMMER AND PADDER CONDENSER	 FILAMENT
 POTENTIOMETER	 I.F. TRANSFORMER (DOUBLE-TUNED)	 CATHODE
 TAPPED RESISTOR OR VOLTAGE DIVIDER	 POWER SWITCH (S.P.S.T.)	 GRID
 RHEOSTAT	 SWITCH (S.P.D.T.)	 PLATE
 AIR-CORE CHOKE COIL	 SWITCH (D.P.S.T.)	 3-ELEMENT VACUUM TUBE
	 SWITCH (D.P.D.T.)	 ALIGNING KEY OF OCTAL BASE